

(19) World Intellectual Property
Organization
International Bureau



(43) International Publication Date
11 November 2004 (11.11.2004)

PCT

(10) International Publication Number
WO 2004/096082 A2

- (51) International Patent Classification⁷: **A61F**
- (21) International Application Number:
PCT/US2004/012758
- (22) International Filing Date: 26 April 2004 (26.04.2004)
- (25) Filing Language: English
- (26) Publication Language: English
- (30) Priority Data:
60/465,134 24 April 2003 (24.04.2003) US
- (71) Applicant (for all designated States except US): **THE BOARD OF REGENTS OF THE UNIVERSITY OF TEXAS SYSTEM** [US/US]; 201 W. 7th Street, Suite 820, Austin, TX 78701 (US).
- (72) Inventors; and
- (75) Inventors/Applicants (for US only): **ESENALIEV, Rinat, O.** [US/US]; 6315 Central City Blvd. #117, Galveston, TX 77551 (US). **PROUGH, Donald S.** [US/US]; 2602 Avenue 0, Galveston, TX 77550 (US).
- (74) Agent: **STROZIER, Roibert**; P.O. Box 429, 5300 Braeswood Blvd., #369, Houston, Texas 77402 (US).
- (81) Designated States (unless otherwise indicated, for every kind of national protection available): AE, AG, AL, AM, AT, AU, AZ, BA, BB, BG, BR, BW, BY, BZ, CA, CH, CN, CO, CR, CU, CZ, DE, DK, DM, DZ, EC, EE, EG, ES, FI, GB, GD, GE, GH, GM, HR, HU, ID, IL, IN, IS, JP, KE, KG, KP, KR, KZ, LC, LK, LR, LS, LT, LU, LV, MA, MD, MG, MK, MN, MW, MX, MZ, NA, NI, NO, NZ, OM, PG, PH, PL, PT, RO, RU, SC, SD, SE, SG, SK, SL, SY, TJ, TM, TN, TR, TT, TZ, UA, UG, US, UZ, VC, VN, YU, ZA, ZM, ZW.
- (84) Designated States (unless otherwise indicated, for every kind of regional protection available): ARIPO (BW, GH, GM, KE, LS, MW, MZ, NA, SD, SL, SZ, TZ, UG, ZM, ZW), Eurasian (AM, AZ, BY, KG, KZ, MD, RU, TJ, TM), European (AT, BE, BG, CH, CY, CZ, DE, DK, EE, ES, FI, FR, GB, GR, HU, IE, IT, LU, MC, NL, PL, PT, RO, SE, SI, SK, TR), OAPI (BF, BJ, CF, CG, CI, CM, GA, GN, GQ, GW, ML, MR, NE, SN, TD, TG).
- Published:**
— without international search report and to be republished upon receipt of that report
- For two-letter codes and other abbreviations, refer to the "Guidance Notes on Codes and Abbreviations" appearing at the beginning of each regular issue of the PCT Gazette.

(54) Title: NONINVASIVE BLOOD ANALYSIS BY OPTICAL PROBING OF THE VEINS UNDER THE TONGUE

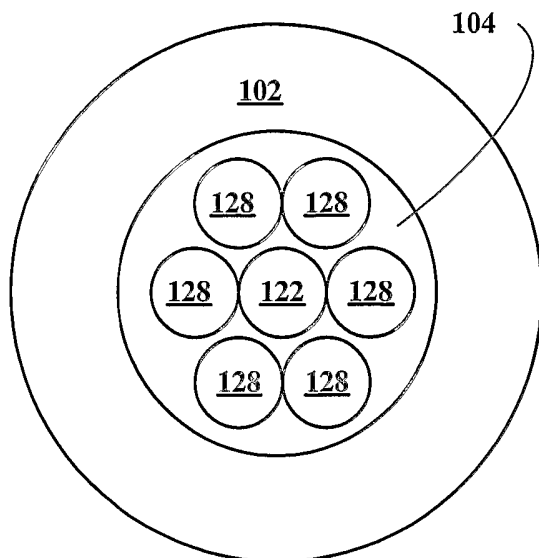

(57) Abstract: A method for analysis of blood components or parameters is disclosed where a probe having an excitation outlet and a response inlet is placed in proximity to or in contact with a tissue of an underside of a patient's tongue over a big vein in the tongue so that an excitation signal exits the outlet, produces a response which enters the inlet for detection and analysis.

WO 2004/096082 A2

NONINVASIVE BLOOD ANALYSIS BY OPTICAL PROBING OF THE VEINS UNDER THE TONGUE

ASSIGNEE: The Board of Regents of the University of Texas System

RELATED APPLICATIONS

[0001] This PCT Application, under United States law, claims provisional priority to United States Provisional Patent Application Serial No. 60/465,134, filed 24 April 2003.

BACKGROUND OF THE INVENTION

1. Field of the Invention

[0002] The present invention relates to a novel system and method for non-invasive analysis of blood including blood components and analytes.

[0003] More particularly, the present invention relates to a novel system and method for non-invasive analysis of blood including blood components and analytes, where the system is portable and pocket-sized and includes a probe having a tip designed to be placed in proximity to or in direct contact with tissue over a big vein on the underside of a patient's tongue, where the tip includes an excitation port through which an input signal generated by a signal generator subsystem impinges on a surface of tissue over the vein and a response port through which a response signal is received by and forwarded to a detector and analyzer or a detector/analyzer, which converts the response signal into a concentration of a blood component and/or a value of a blood parameter.

2. Description of the Related Art

[0004] Analysis of blood is needed for diagnostic and management of various diseases and conditions as well as for screening of healthy population. Current techniques and systems for blood analysis are invasive, require blood sampling, and cannot be performed in real time or continuously. At present, blood is usually analyzed in clinical laboratories after taking blood samples with invasive techniques.

[0005] Thus, there is a need in the art for a technique and system for noninvasive analysis of blood that would benefit a large population of patients and healthy people as well.

SUMMARY OF THE INVENTION

[0006] The present invention provides a system for non-invasive analysis of blood, including a probe having a tip designed to be placed in proximity to or in direct contact with tissue over

a big vein on the underside of a patient's tongue, where the tip includes an excitation port through which an input signal generated by a signal generator subsystem impinges on a surface of the tissue over the vein and a response port through which a response signal is received by and forwarded to a detector and analyzer or a detector/analyzer, which converts the response signal into concentration of a blood component and/or a value of a blood parameter.

[0007] The present invention also provides a portable and pocket-sized system for non-invasive analysis of blood, including a probe having a tip designed to be placed in proximity to or in direct contact with tissue over a big vein on the underside of a patient's tongue, where the tip includes an excitation port through which an input signal generated by a signal generator subsystem impinges on a surface tissue over the vein and a response port through which a response signal is received by and forwarded to a detector and analyzer or a detector/analyzer, which converts the response signal into concentration of a blood component and/or a value of a blood parameter.

[0008] The present invention also provides a portable and pocket-sized system for non-invasive analysis of blood including an under the tongue apparatus comprising two side portions adapted to fit over teeth on each side of the lower jaw, a depressed portion between the two side portions including an excitation port through which an input signal generated by a signal generator subsystem impinges on a surface tissue over the vein and a response port through which a response signal is received by and forwarded to a detector and analyzer or a detector/analyzer, which converts the response signal into a concentration of a blood component and/or a value of a blood parameter.

[0009] The present invention also provides a system, including an excitation signal generator, a probe including a tip designed to be placed in proximity to or in contact with tissue over a big vein on the underside of a patient's tongue and having an excitation signal port connected to the generator via a signal transmission conduit and a response port connected to a detector which is in turn connected to an analyzer or a detector analyzer, where the analyzer converts the response signal into a concentration of a blood component and/or a value of a blood parameter.

[0010] The present invention also provides a portable and pocket-sized system for non-invasive glucose and/or cholesterol measuring and monitoring including a probe having a tip designed to be placed in proximity to or in direct contact with tissue over a big vein on the

underside of a patient's tongue, where the tip includes an excitation port through which an input signal generated by a signal generator subsystem impinges on a tissue surface over the vein and a response port through which a response signal is received by and forwarded to a detector and analyzer or a detector/analyzer, which converts the response signal into concentrations of glucose and/or cholesterol in the blood.

[0011] The present invention also provides a portable and pocket-sized system for non-invasive hemoglobin, hematocrit, oxy-hemoglobin, deoxy-hemoglobin, carboxyhemoglobin, and/or glycosylated or glycated hemoglobin measuring and monitoring including a probe having a tip designed to be placed in proximity to or in direct contact with tissue over a big vein on the underside of a patient's tongue, where the tip includes an excitation port through which an input signal generated by a signal generator subsystem impinges on a tissue surface of the vein and a response port through which a response signal is received by and forwarded to a detector and analyzer or a detector/analyzer, which converts the response signal into concentrations of hemoglobin, hematocrit, oxy-hemoglobin, deoxy-hemoglobin, carboxyhemoglobin, and/or glycosylated or glycated hemoglobin in the blood.

[0012] The present invention provides a method for measuring and/or monitoring blood components and/or parameters including the steps of placing a tip of a probe having an excitation port and a response port in proximity to or in direct contact with tissue over a big vein on the underside of a patient's tongue. Once the tip is in proximity to or in contact with the tissue over the vein, an excitation signal is transmitted into the vein through the excitation port, where the excitation signal is generated by a signal generator connected to the excitation port of the probe via a signal transmission conduit. After the excitation signal or input signal is transmitted into the vein, the response port receives a response signal and detects the response signal in a detector.

[0013] The present invention provides a method for measuring and/or monitoring blood components and/or parameters including the steps of placing a tip of a probe having an excitation port and a response port in proximity to or in direct contact with tissue over a big vein on the underside of a patient's tongue. Once the tip is in proximity to or in contact with the tissue over the vein, an excitation signal is transmitted into the vein through the excitation port, where the excitation signal is generated by a signal generator connected to the excitation port of the probe via a signal transmission conduit. After the excitation signal or input signal is transmitted into the vein, the response port receives a response signal directly through a

detector that generates a detector signal which is transmitted via a detector signal conduit to an analyzer or via a response signal conduit to a detector/analyzer. Once the signal has been detected, the analyzer converts the detected signal into a concentration of a blood component and/or a value of a blood parameter.

DESCRIPTION OF THE DRAWINGS

[0014] The invention can be better understood with reference to the following detailed description together with the appended illustrative drawings in which like elements are numbered the same:

[0015] Figures 1A-C depict three preferred embodiments of apparatuses of this invention;

[0016] Figures 1D-G depict three preferred embodiments of probes of this invention;

[0017] Figures 1H depict another embodiment of apparatus of this invention;

[0018] Figure 2 depicts another preferred embodiment of an apparatus of this invention, designed like an under tongue retainer;

[0019] Figure 3 depicts a reflectance spectra measured from sheep blood at different THb;

[0020] Figures 4 depicts a reflectance spectra measured from blood in vitro, the two veins (V1 and V2), and tongue tissue (T1, T2, and T3) on the underside of the tongue;

[0021] Figure 5 depicts a reflectance signal from sheep blood vs. THb at 805 nm;

[0022] Figures 6A-B depict a reflectance signal from circulating sheep blood vs. THb at 805, 1300, and 1450 nm and measurements performed through 0.15-mm glass slide;

[0023] Figures 7A-B depict a reflectance spectra measured from sheep blood at different Thb and measurements performed by using a probe with 3-mm distance between irradiation and detection fibers through 0.15-mm glass slide;

[0024] Figures 8A-B depict a reflectance signal from sheep blood vs. THb at 805 nm (a) and 1300 nm (b), where measurements were performed through 0.15-mm glass slide;

[0025] Figures 9A-B depict a total diffuse reflectance spectra (R_d) measured from sheep blood at different Thb, where measurements were performed by using an integrating sphere that collects all diffusively reflected light;

[0026] Figures 10A-B depict a total diffuse reflectance from sheep blood at 805 nm and 1300 nm (a) and the ratio $R_d(1300)/R_d(805)$ (b) vs. THb, where measurements were performed with the integrating sphere; and

[0027] Figures 11A-B depict a total diffuse reflectance v.s wavelength from sheep blood for THb 14.8 g/dL.

DETAILED DESCRIPTION OF THE INVENTION

[0028] The inventor has found that a novel system and method for non-invasive analysis of blood including blood components and analytes can be constructed and used. Portable, pocket-sized devices can be developed for home and clinical use based on this technique permitting wide application for the apparatuses of this invention.

[0029] The technique is based on optical analysis of blood circulating in a big vein under a patient's tongue. Light from an optical probe of an apparatus of this invention is directed into one of these veins by bringing a probe tip in close proximity to or in contact with the surface of tongue tissue above the vein, *i.e.*, the tip of the probe is brought into proximity to or in contact with epithelial tissue overlying the big veins beneath the surface of the underside of the tongue. Non-contact analysis may ultimately be the preferred method from a medical and practical point of view because the tip does not make contact with the tissue, thereby reducing the possibility of infections. The emitted light interacts with blood flowing through the vein, producing a signal. The produced or output signal is received or received and measured by the probe, where the output signal will depend on optical properties of the blood. The optical properties of the blood are related to concentrations of blood components. Because the tissues between the probe tip and blood circulating in the vein is very thin, the output signals received by the apparatuses of this invention have minimal influences from the intervening tissue (*i.e.*, minimal background signals) caused by light scattering and absorption in the intervening tissue.

[0030] The term "in proximity to" means that the probe tip is sufficiently close to the surface tissue of the underside of the tongue of a patient to produce a response signal of sufficient intensity to be measured. Generally, the distance is between about 10 mm and about 1mm, with distances between about 5 mm and 1 mm being preferred. However, larger or smaller distances can be used as well provided an analyzable signal can be detected. The term "in contact with" means that the probe tip actually makes physical contact with the tissue of the underside of the patient's tongue.

[0031] The excitation light can be in the near infrared (wavelength range from about 760 to about 2,500 nm), the visible (wavelength range from about 400 to about 760 nm), or the near UV (from about 250 to about 400 nm) portions of the electromagnetic spectrum. These portions of the electromagnetic spectrum would have insignificant background signals due to relatively low scattering and absorption in the intervening tissue compared with light from

other spectral ranges.

[0032] The method and system of this invention can utilize any optical detection technique or hybrid detection techniques including, but not limited to, reflectance techniques, confocal techniques, scanning confocal techniques, polarization techniques, interferometry techniques, optoacoustic techniques, low coherence reflectometry techniques, techniques based on speckle measurements, or similar techniques or mixtures or combinations thereof.

[0033] One preferred application of this invention is noninvasive measurement of hemoglobin concentration and/or hematocrit in blood. Other applications of the systems and methods of this invention include, without limitation, noninvasive measurements of glucose and/or cholesterol concentrations in blood and potentially can be used for measuring oxy-, deoxy-, carboxyhemoglobin, and/or glycosylated hemoglobin concentrations in blood. Other applications include, without limitation, measuring or monitoring analytes, drugs, exogenous substances, and/or blood parameters (such as pH).

[0034] This technique can be used for blood analysis of healthy population and patients with various diseases and disorders including critically ill patients.

[0035] Referring now to **Figures 1A-D**, a preferred embodiment of a system of this invention, generally **100**, is shown to include a probe **102** having a tip **104**, which is in proximity to or in contact with a surface tissue **106** over a vein **108** of an underside **109** of a patient's tongue **110**. The system **100** also includes a light delivery subsystem **112** and detection/analysis subsystem **114**. The light delivery subsystem **112** terminates in the probe tip **104** at a light outlet or port **116**, while the detection/analysis subsystem **114** begins in the tip **104** at an output or response signal inlet or port **118**. The light delivery subsystem **112** includes a light source **120** and a light conduit **122** terminating at the light outlet **116**. Preferably, the light conduit **122** is an optical fiber or optical fiber bundle and the light source **120** is a laser or filtered broad spectrum light source (*e.g.*, lamp). The detection/analysis subsystem **114** includes a detector **124**, an analyzer unit **126** and a signal conduit **128** interconnecting the detector **124** and the analyzer **126**. The detector **124** can be located in the tip **104** as shown in **Figure 1A**, in the probe **102** as shown in **Figure 1B** or in the analyzer unit **126** as shown in **Figure 1C**. The output signal forwarded to the analyzer **126** can be optical and/or acoustic, if the detector **124** is located in the analyzer **126** or electrical, if the detector **124** is located in the probe **104**.

[0036] Referring now to **Figures 1D-G**, several probe tip and optical fiber arrangements are

shown. Looking at **Figure 1D**, the light conduit **122** is a single optical fiber, while the signal conduit **128** includes six optical fibers surrounding the light conduit **122** for a cylindrical probe **102** and circular probe tip **104**. Looking at **Figure 1E**, the light conduit **122** includes four fibers and the signal conduit **128** includes four optical fibers surrounding the light conduit **122** arranged side by side for an oval shaped probe **102** and tip **104**. Looking at **Figure 1F**, the light conduit **122** includes four fibers and the signal conduit **128** includes four optical fibers surrounding the light conduit **122** arranged intermixed for a rectangular probe **102** and probe tip **104**. Looking at **Figure 1G**, the light conduit **122** includes one fiber and the signal conduit **128** includes three optical fibers surrounding the light conduit **122** for a triangular probe **102** and probe tip **104**.

[0037] Looking at **Figure 1H**, the system **100** works by placing the probe tip **104** in contact with the surface tissue **106** over the vein **108**. In this figure, the probe **102** also includes a finger grip **103** for better control of the probe tip placement. The light delivery system **112** is then activated, turned on, and excitation radiation travels from the light source **120** through the light conduit **122** and out the light outlet **116** in the probe tip **104**. The excitation radiation then propagates through the surface tissue **106**, a relatively thin tissue layer, and into the vein **108** where a response signal is produced. The response signal then enters the signal port **118** where it is either detected by the detector **124** in the probe **102** or the probe tip **104** or travels down the signal conduit **128** to the detector **124** associated with the analyzer unit **126**. The detector **124** converts the signal into a detector response and the analyzer converts the response into a concentration of a blood component and/or a value of a blood parameter.

[0038] Referring now to **Figure 2**, a second embodiment of an apparatus of this invention, generally **200**, is shown to include a first teeth engaging side section **202a**, a second teeth engaging side section **202b**, a first and a second downwardly extending sections **204a&b** and a middle section **206** bridging the two downwardly extending sections **204a&b** adapted to contact the underside of a patient's tongue (not shown). The middle section **206** includes two emitters **208a&b** and two receivers **210a&b**. Extending from the two emitters **208a&b** and the two detectors **210a&b** are light conduits **212a&b**, shown here as two optical fibers **214a&b** terminating at the emitters **208a&b**, and signal conduits (light or sound) **216a&b**, also shown here as two optical fibers **218a&b** terminating at the receivers. The light conduits **212a&b** are connected to a light source **220**, while the signal conduits **216a&b** are connected to a detector/analyzer **222**.

THEORETICAL SECTION OF THE INVENTION

[0039] Most tissues are strongly scattering media in the visible and near-IR spectral range. Three major optical parameters are responsible for distribution of light in tissues: 1) the absorption coefficient (μ_a); 2) the scattering coefficient (μ_s); and 3) the effective attenuation (μ_{eff}) coefficient. The effective attenuation coefficient (μ_{eff}) is related to μ_a , μ_s , and the anisotropy factor (g) thusly:

(1)

where $\mu_s(1-g)$ is the reduced scattering coefficient, μ_s' [1]. Light penetration depth in tissues is defined as $1/\mu_{\text{eff}}$. Absorption and reduced scattering coefficients of tissues are moderate in the visible spectral range and low in the near-IR spectral range (from 600 to 1600 nm), which results in deeper penetration of visible and especially near-IR radiation compared with that of other parts of the spectrum. Application of visible or near-IR radiation will allow insignificant attenuation of light in the thin tissues between the vein on the underside of the tongue and the probe.

[0040] Hemoglobin has a high absorption coefficient in the visible and near-IR spectral range that is dependent on hemoglobin oxygen saturation (the ratio of oxyhemoglobin to total hemoglobin (THb) [1]). The blood absorption coefficient, μ_a [blood], is related to oxyhemoglobin concentration (C[oxy]) and deoxyhemoglobin concentration (C[deoxy]) as follows:

$$\mu_a [\text{blood}] = C[\text{oxy}] \times K[\text{oxy}] + C[\text{deoxy}] \times K[\text{deoxy}] \quad (2)$$

where $K[\text{oxy}]$ and $K[\text{deoxy}]$ are known values of extinction coefficients of oxy- and deoxyhemoglobin at a given wavelength. Since $K[\text{oxy}] = K[\text{deoxy}] = K$ at isosbestic wavelengths and $\text{THb} = C[\text{oxy}] + C[\text{deoxy}]$, one can measure hemoglobin in the veins because:

$$\mu_a [\text{blood}] = \text{THb} \times K \quad (3)$$

[0041] The tissue between the vein on the underside of the tongue and the probe is optically thin in the visible and near IR spectral ranges because: $\mu_{\text{eff}} \times L \ll 1$ due to relatively low μ_{eff} ($\sim 1 - 5 \text{ cm}^{-1}$) and small L ($\sim 0.01-0.02 \text{ cm}$). In contrast, blood in the vein is optically thick: $\mu_{\text{eff, blood}} \times L_{\text{blood}} \gg 1$ because $\mu_{\text{eff, blood}}$ is high ($\sim 10 \text{ cm}^{-1}$) and L is about 2 to 3 mm. Attenuation in the tissue is insignificant and all signal will be from blood. The signal from the deeper tissues will not be significant due to strong light attenuation by blood in the vein.

EXPERIMENTAL DATA OF THIS INVENTION

[0042] **Figure 3** shows diffuse reflectance spectra obtained from sheep blood at different total hemoglobin concentration (THb) through the cylindrical wall (thickness 0.8 mm) of a 10-mL syringe. Blood with an initial THb of 8.2 g/dL, oxygenation of 56%, and volume of 5 mL was progressively diluted with saline with increments of 0.5 mL. The final concentration was 4.1 g/dL. The spectra were obtained with a portable (pocket size) spectrometer (range from 600 to 1180 nm) operated with a laptop computer. This range included the isobestic wavelength of 805 nm, where oxy- and deoxyhemoglobin have the same absorption coefficient. Therefore, variations of blood oxygenation do not influence the accuracy of THb measurement at this wavelength. The sample was irradiated by a tungsten lamp (the lamp and its power supply are compact: pocket size; designed for this spectrometer) through a reflection probe combining one 0.4-mm illumination fiber and six 0.4-mm fibers around it for detection of the reflectance signal. The system was calibrated with a reflectance standard with 25% reflectivity. The standard is being widely used for calibration of optical spectroscopic instruments in a wide spectral range that includes ultraviolet (UV), visible, and near infra-red (near-IR) spectral ranges.

[0043] The diffuse reflectance signal is due to light scattering from red blood cells in blood. All spectra had: (1) a minimum at 760 nm due to the absorption peak (maximum of absorption) at this wavelength for deoxygenated hemoglobin and (2) low intensity at 600 nm due to strong absorption by hemoglobin. The spectra were dependent on THb. In this geometry of irradiation, the reflectance signal first increased and then decreased with dilution.

[0044] Since the tissues between the blood circulating in the tongue vein and the probe are very thin (0.1-0.2 mm), they are optically thin in the visible and near-IR spectral ranges due to low tissue absorption. Therefore, the reflectance signal from blood circulating in the vein is not influenced by variation of optical properties of the tissue. **Figure 4** shows representative reflectance spectra measured: (1) in vitro from blood; (2) in vivo from the two big veins (V1 and V2) on underside of the tongue of a healthy volunteer; and (3) at three locations: right, left and middle part of the underside of the tongue (T1, T2, and T3, respectively). It is clearly seen that the spectra measured from the veins are similar to that of blood. As in pure blood, the spectra have minimum values at 760 nm and low intensity at 600 nm. The spectra measured from the tongue tissue are different from that of pure blood: high intensity at 600 nm and no minimum at 760 nm.

[0045] The reflectance signal at a given THb and oxygenation is dependent on wavelength and the reflectance probe configuration. We performed experiments with different probes in a wide spectral range with two spectrometers operating in the range from 520 to 1180 nm and from 900 to 1700 nm.

[0046] **Figure 5** shows the reflectance signal at 805 nm vs. THb for the spectra presented in **Figure 3**. The signal is linearly dependent on THb from 4.1 to 6.3 g/dL.

[0047] Another set of experiments was performed with circulating centrifuged sheep blood. Typically, THb of sheep blood (6-9 g/dL) is lower than that of human blood (11-16 g/dL). By using the centrifuge one can obtain blood with THb up to 14-16 g/dL (typical for human blood). To simulate the gap of 0.1-0.2 mm between the veins and the probe, we used a thin (0.15 mm) microscopic glass slide cover. **Figure 6A and 6B** show reflectance spectra obtained from blood (initial THb of 14.1 g/dL) with the two spectrometers, respectively. Both spectra were measured simultaneously by using a fiber-optic splitter attached to the detection fibers of the probe. One can see that the spectra are dependent on THb in both spectral ranges. Reflectance signals are presented as a function of THb for 805 and 1300 nm in **Figure 7A**. The dependence was linear up to approximately 8 and 9 g/dL for the wavelengths of 805 and 1300 nm, respectively. At 1450 nm, it was linear up to 10 g/dL as shown in **Figure 7B**.

[0048] Blood dilution lowers both the absorption coefficient (which is proportional to THb up to 1150 nm) and the scattering coefficient (which is proportional to hematocrit). In general, total diffuse reflection (all photons that are reflected from tissue due to scattering) decreases with the absorption coefficient and increases with scattering coefficient and should be constant for tissues if both these coefficients decrease proportionally. However, spatial distribution of the diffusively reflected light varies with blood dilution. Therefore, the reflection signal from blood is strongly dependent on the distance between the irradiation and detection fiber. To accurately measure THb and hematocrit, one needs to find a configuration of the probe with optimal distance between the irradiation and detection fibers. We performed a set of experiments with a probe that has a 3-mm distance between irradiation and detection fibers. Gradual increase of the reflectance signal was obtained in a wide spectral range from 600 to 1180 nm as shown in **Figure 7A&B** with blood dilution. **Figure 8A&B** demonstrated the increase of the reflectance signal with dilution at 805 and 1130 nm, respectively. The increase of the reflectance signal with THb is due to deeper penetration of

light in blood (decrease of blood effective attenuation coefficient). More photons can reach the detection fiber (separated by 3 mm from the irradiation fiber) at lower effective attenuation coefficient.

[0049] The obtained results demonstrate that one can measure THb and hematocrit with this technique if optimum probe configuration and wavelengths are used. A probe with detection fibers aligned on one or two opposite sides from the irradiation fiber (and along the vein) may provide very accurate measurement because the value of the signals measured at different distances from the irradiation fiber can be used in the calculation of THb and hematocrit.

[0050] To find optimal wavelength we measured total diffuse reflectance R_d of blood with an integrating sphere and both spectrometers. The studies with integrating spheres are being used for measurement of optical properties of absorbing and scattering media. Sheep blood was centrifuged and gradually diluted as described above. The integrating sphere allowed to detect all photons reflected back due scattering by blood cells. **Figure 9A-B** shows spectra obtained from sheep venous blood (initial THb = 14.8 g/dL; oxygenation = 57%; Hct = 44.4%) at different THb concentrations. Decrease of THb resulted in different changes in different part of the spectra. One can see that the oxygenation gradually increased (the maximum at 760 nm is less pronounced at lower THb) due to penetration of oxygen in blood during dilutions. However, variations of the oxygenation in blood do not affect accuracy of measurements, if we use isosbestic wavelengths for analysis of the data and calibration of the system.

[0051] We plotted R_d vs. THb at two isobestic wavelengths: 805 and 1300 nm as shown in **Figure 10A**. We also calculated the ratio $R_d(1300\text{nm})/R_d(805\text{nm})$ and obtained a linear dependence in the whole range of THb (from 3.6 to 14.8 g/dL) with the correlation coefficient of $R^2 = 0.998$ as shown in **Figure 10B**. This demonstrates good correlation between the ratio $R_d(1300\text{nm})/R_d(805\text{nm})$ and THb and indicates that this ratio can be used for accurate measurement of THb. The linear dependence was obtained at these wavelength because: (1) $R_d \sim \mu_s' / \mu_a$ at relatively high μ_a typical of blood and (2) μ_a at 805 nm is linearly proportional to THb (negligible water absorption) and is constant at 1300 nm (negligible Hb absorption). This combination results in the linear dependence of $R_d(1300\text{nm})/R_d(805\text{nm})$ vs. THb.

[0052] One can use these two wavelengths and this algorithm to accurately measure THb. We designed, built, and tested a compact inexpensive laser diode based-system operation at two wavelengths: 1300 nm and 790 nm (which is close to 805 nm). Although the use of

integrating spheres (irradiation and detection window of about 1 cm) is possible for the noninvasive blood analysis, it is easier and more practical to use probes with smaller size.

[0053] We used a probe with one 0.4-mm fiber for illumination and six 0.4-mm fibers around it for detection. Same blood samples that we used in the studies with the integrating sphere were irradiated in a plastic cuvette (blood volume 0.3 mL; thickness - 4 mm) through a thin plastic film (thickness - 0.13 mm) simulating thin tissue between the vein and the surface of the underside of the tongue. **Figure 11A** shows the dependence of the reflectance signal at 790 and 1300 nm vs. THb that is similar to R_d vs. THb at the two isobestic wavelengths (805 and 1300 nm). Although the dependence of the ratio $R(1300\text{nm})/R(790\text{nm})$ vs. THb is not linear as shown in **Figure 11B**, it can be used for calibration of the system. The dependence is not linear because of the following two reasons: the detection fibers collect light scattered almost backward (not in all directions as in the case of the integrating sphere) and 790 nm is not exactly at the isobestic point.

[0054] All references cited herein are incorporated by reference. While this invention has been described fully and completely, it should be understood that, within the scope of the appended claims, the invention may be practiced otherwise than as specifically described. Although the invention has been disclosed with reference to its preferred embodiments, from reading this description those of skill in the art may appreciate changes and modification that may be made which do not depart from the scope and spirit of the invention as described above and claimed hereafter.

CLAIMS

We claim:

1. A method for noninvasive analysis of at least one blood component comprising the steps of:
 - irradiating blood in a big vein associated with an underside of a patient's tongue with radiation having at least one frequency or wavelength;
 - detecting a response from blood irradiated in the irradiating step;
 - calculating a concentration of a blood component, a value of a blood parameter or a mixture or combination thereof.
2. The method of claim 1, further comprising the step of:
 - displaying at least one result from the calculating step.
3. The method of claim 1, further comprising the step of:
 - utilizing one or a combination of techniques selected from the group consisting of reflectance technique, confocal technique, scanning confocal technique, polarization techniques, interferometry, optoacoustics, low coherence interferometry and reflectometry, techniques based on speckle measurements, fluorescence technique, Raman scattering technique, and two or multi-photon techniques
4. The method of claim 1, wherein the radiation is in a spectral range from about 200 nanometers to about 20 microns.
5. The method of claim 1, wherein the response corresponds to a concentration of hemoglobin in the blood and the radiation is in a spectral wavelengths selected from the group consisting of 548 nm, 568 nm, 587 nm, and 805 nm (the isosbestic points) and spectral ranges from about 400 nm to about 640 nm and above about 1120 nm where absorption coefficients of oxy- and deoxygenated blood are close to each other.
6. The method of claim 1, wherein the response corresponds to hematocrit.

7. The method of claim 1, wherein the response corresponds to a concentrations of hemoglobin and/or glycosylated hemoglobin, where the detection and quantitation of hemoglobin and/or glycosylated hemoglobin.

8. The method of claim 1, wherein the response corresponds to a concentration of glucose.

9. The method of claim 1, wherein the response corresponds to a concentration of cholesterol.

10. The method of claim 1, wherein the response corresponds to a concentrations of oxy-hemoglobin, deoxy-hemoglobin, and carboxy-hemoglobin.

11. The method of claim 1, wherein the response corresponds to a concentration of an exogenous substance.

12. The method of claim 1, wherein the exogenous substance is selected from the group consisting of a drug, a dye or other reporter in molecular state or a particle made of liquid, gas, or solid material including polymer, metal, semiconductor, dielectric, or a combination of liquid, gas, or solid materials, and a layered structure.

13. The method of claim 1, wherein the exogenous substance selected from the group consisting of indocyanine green and Evans blue.

14. The method of claim 1, wherein the exogenous substance that are particles with a size from about 0.1 nanometer to about 10 microns.

15. The method of claim 1, wherein the radiation is microwave radiation.

16. The method of claim 1, wherein the radiation is radiofrequency radiation.

17. The method of claim 1, wherein the radiation is ultrasound radiation.
18. The method of claim 1, wherein the radiation is low-frequency electromagnetic radiation.
19. The method of claim 1, further comprising:
using a static electric or magnetic field.
20. The method of claim 1, further comprising
using a hybrid technique for irradiation and detection.
21. The method of claim 1, wherein the radiation comprises one, two, or many
wavelengths (frequencies).
22. An apparatus for noninvasive blood analysis comprising:
a probe including a tip having a radiation outlet and a response inlet, where the probe
tip is adapted to be placed in proximity to or in contact with a surface of a tissue over a big
vein associated with an underside of a patient's tongue;
a light generation/delivery system including a light source capable of generating at
least one frequency of light, and a light conduit interconnecting the light source with the
radiation outlet, where the system is adapted to deliver radiation to blood in the big vein; and
a detector/analyzer system including a detector adapted to detect a response from the
irradiated blood via the response inlet and an analyzer adapted to convert the detected
response into a concentration of a blood component and/or a value of a parameter of the
blood.
23. An apparatus for noninvasive blood analysis comprising:
right side and left side sections adapted to engage one or more teeth on each of a right
side and left side of a patient's jaw,
two transitions section extending downwardly from each of the side sections,

1 a middle section interposed between the two transitions sections adapted to be
2 proximate to or in contact with an underside of a patient's tongue, where the middle section
3 includes;

4 a emitter, and

5 a receiver,

6 where the emitter and the receiver are proximate or in contact with a surface
7 of a tissue over a big vein associated with an underside of the patient's tongue;

8 a light generation/delivery system including a light source capable of generating at
9 least one frequency of light, and a light conduit interconnecting the light source with the
10 radiation outlet, where the system is adapted to deliver radiation to blood in the big vein; and

11 a detector/analyzer system including a detector adapted to detect a response from the
12 irradiated blood via the response inlet and an analyzer adapted to convert the detected
13 response into a concentration of a blood component and/or a value of a parameter of the
14 blood.

15 24. The apparatus of claim 24, further comprising:

16 a plurality of emitters and receivers, located in pairs on a right hand side and a left
17 side of the middle section.

18 25. The apparatus of claims 22, 23 or 24, further comprising:

19 a display adapted to display the response (raw data) or converted response (refined
20 data)

21 26. The apparatus of claims 22, 23 or 24, wherein the radiation is the spectral range from
22 about 200 nanometers to about 20 microns.

23 27. The apparatus of claims 22, 23 or 24, further comprises:

24 one or a combination of techniques selected from the group consisting of reflectance
25 technique, confocal technique, scanning confocal technique, polarization techniques,
26 interferometry, optoacoustics, low coherence interferometry and reflectometry, techniques
27 based on speckle measurements, fluorescence technique, Raman scattering technique, and two
28 or multi-photon techniques

- 1 28. The apparatus of claims 22, 23 or 24, wherein the response corresponds to a
2 concentration of hemoglobin in the blood and the radiation is in a spectral wavelengths
3 selected from the group consisting of 548 nm, 568 nm, 587 nm, and 805 nm (the isosbestic
4 points) and spectral ranges from about 400 nm to about 640 nm and above about 1120 nm
5 where absorption coefficients of oxy- and deoxygenated blood are close to each other.
- 1 29. The apparatus of claims 22, 23 or 24, wherein the response corresponds to hematocrit.
- 1 30. The apparatus of claims 22, 23 or 24, wherein the response corresponds to a
2 concentrations of hemoglobin and/or glycosylated hemoglobin, where the detection and
3 quantitation of hemoglobin and/or glycosylated hemoglobin.
- 1 31. The apparatus of claims 22, 23 or 24, wherein the response corresponds to a
2 concentration of glucose.
- 1 32. The apparatus of claims 22, 23 or 24, wherein the response corresponds to a
2 concentration of cholesterol.
- 1 33. The apparatus of claim 22, wherein the response corresponds to a concentrations of
2 oxy-hemoglobin, deoxy-hemoglobin, and carboxy-hemoglobin.
- 1 34. The apparatus of claims 22, 23 or 24, wherein the response corresponds to a
2 concentration of an exogenous substance.
- 1 35. The apparatus of claims 22, 23 or 24, wherein the exogenous substance is selected
2 from the group consisting of a drug, a dye or other reporter in molecular state or a particle
3 made of liquid, gas, or solid material including polymer, metal, semiconductor, dielectric, or
4 a combination of liquid, gas, or solid materials, and a layered structure.
- 1 36. The apparatus of claims 22, 23 or 24, wherein the exogenous substance selected from
2 the group consisting of indocyanine green and Evans blue.

37. The apparatus of claims 22, 23 or 24, wherein the exogenous substance that are particles with a size from about 0.1 nanometer to about 10 microns.
38. The apparatus of claims 22, 23 or 24, wherein the radiation is microwave radiation.
39. The apparatus of claims 22, 23 or 24, wherein the radiation is radiofrequency radiation.
40. The apparatus of claims 22, 23 or 24, wherein the radiation is ultrasound radiation.
41. The apparatus of claims 22, 23 or 24, wherein the radiation is low-frequency electromagnetic radiation.
42. The apparatus of claims 22, 23 or 24, further comprising:
a static electric or magnetic field.
43. The apparatus of claims 22, 23 or 24, further comprising a hybrid technique for irradiation and detection.
44. The apparatus of claims 22, 23 or 24, wherein the radiation comprises one, two, or many wavelengths (frequencies).

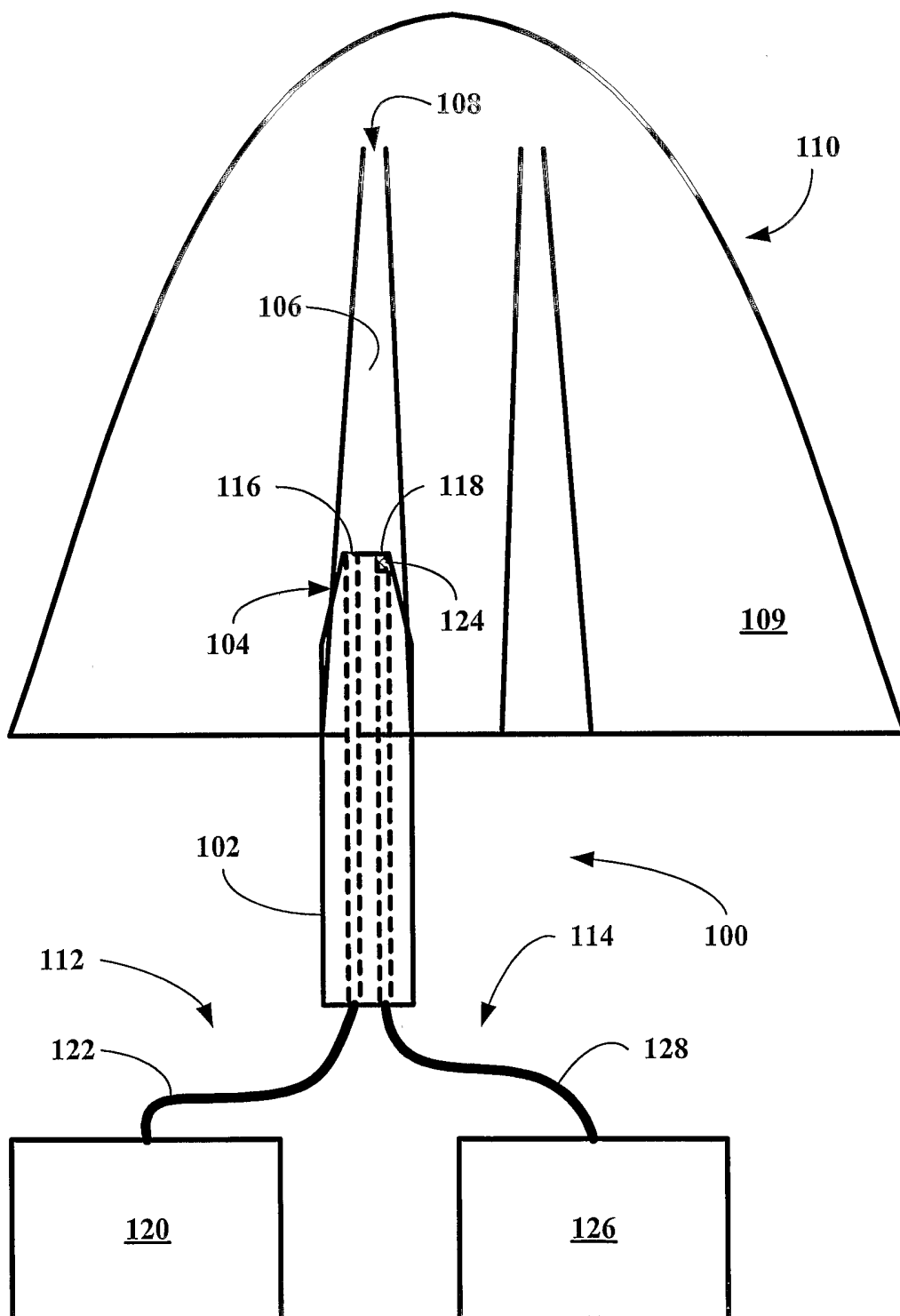

FIG. 1A

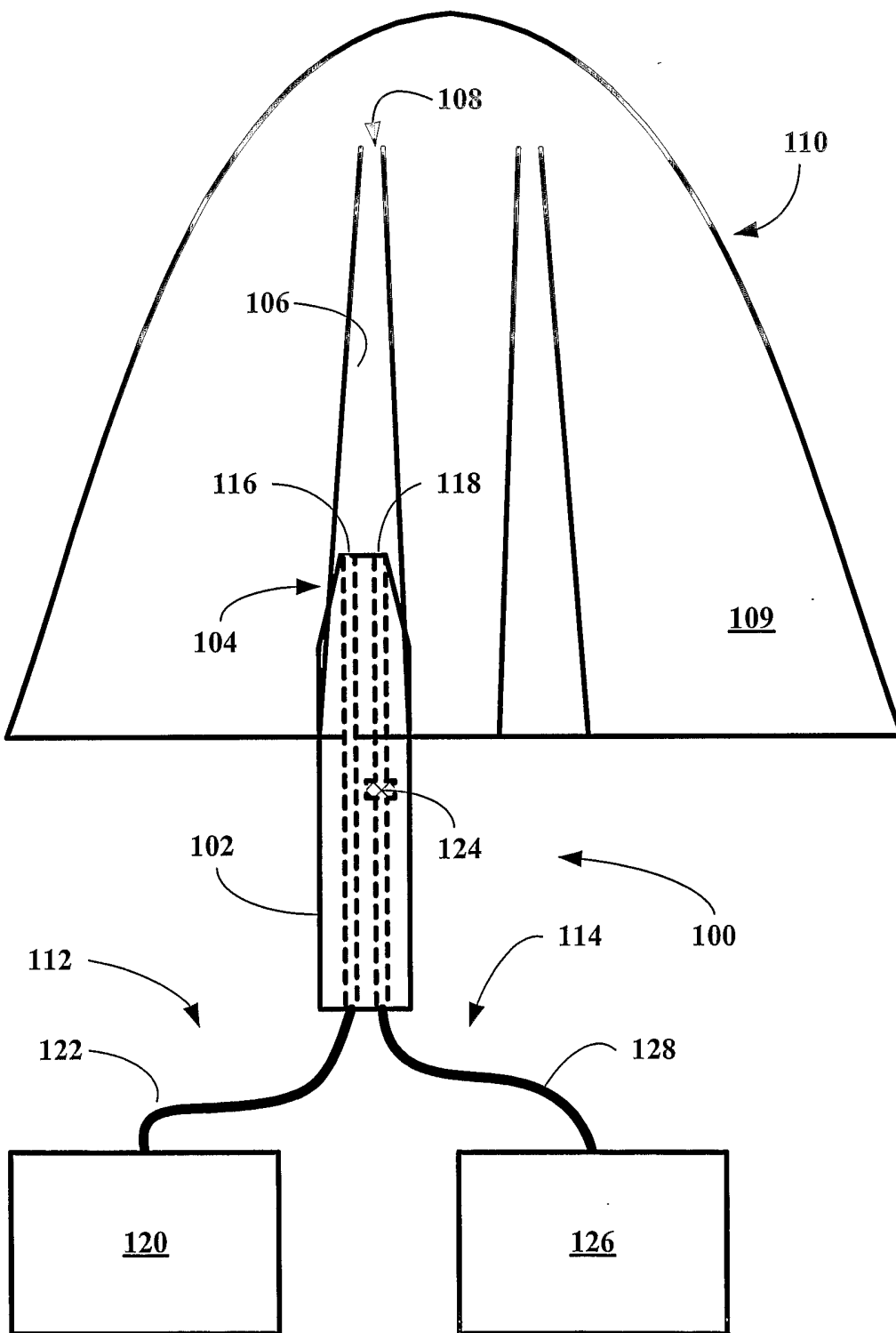

FIG. 1B

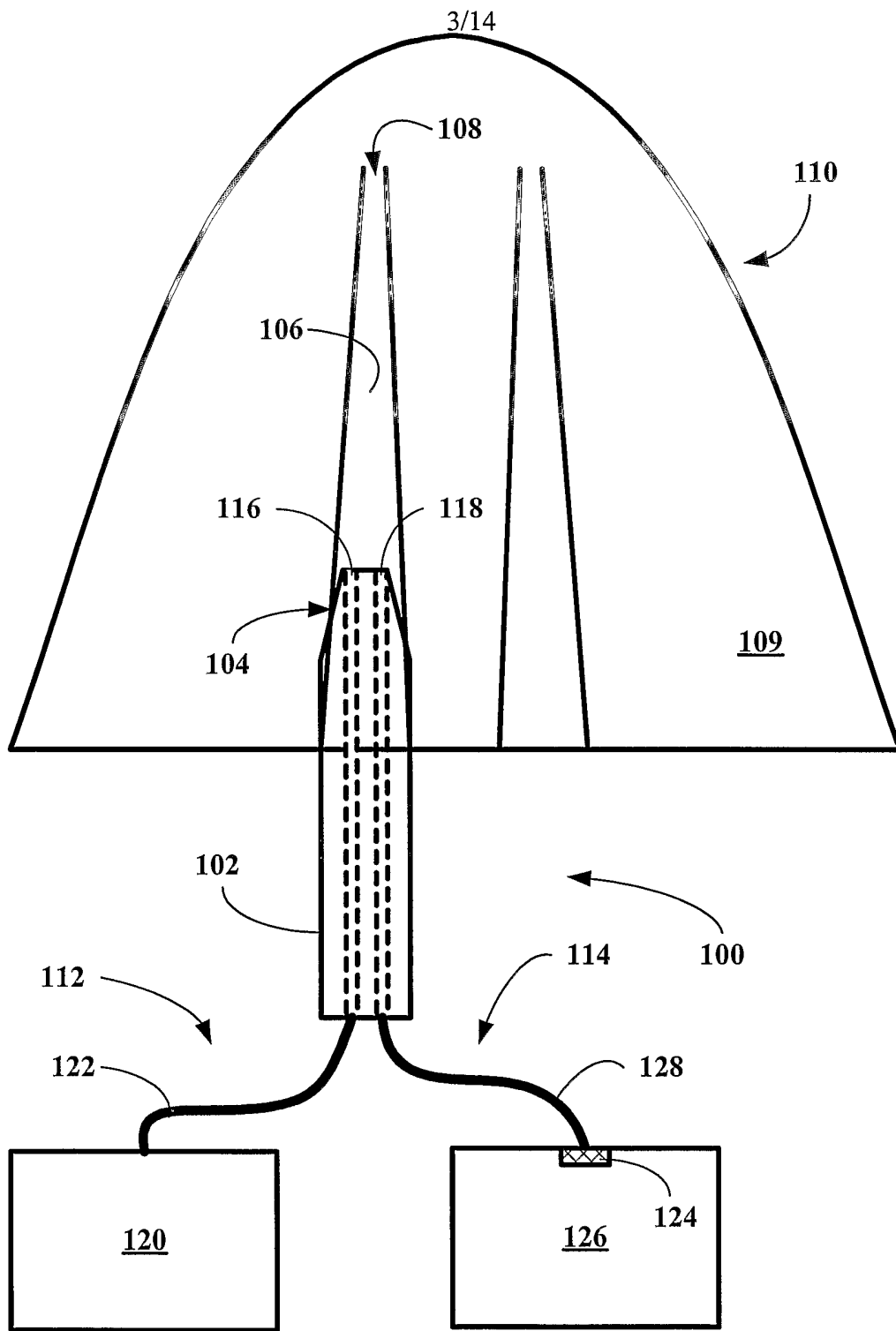

FIG. 1C

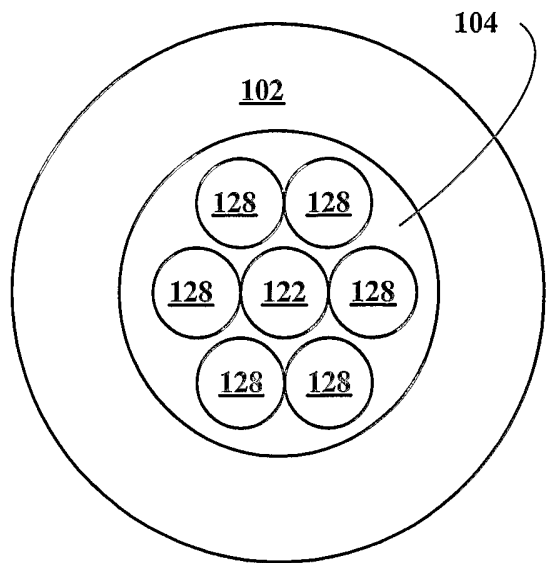

FIG. 1D

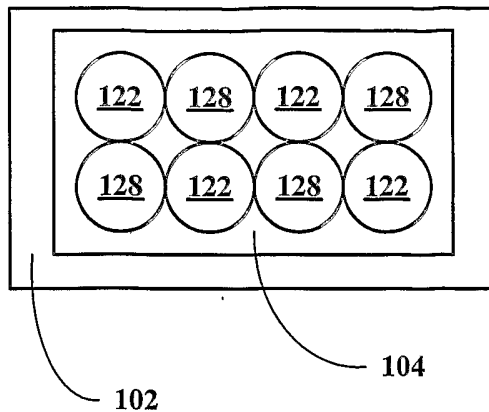

FIG. 1F

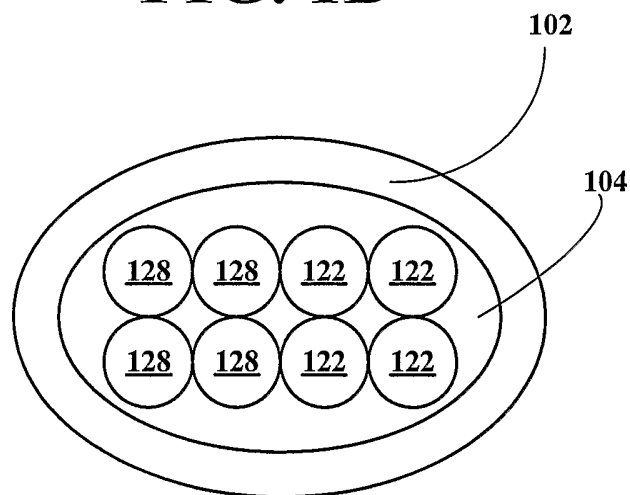

FIG. 1E

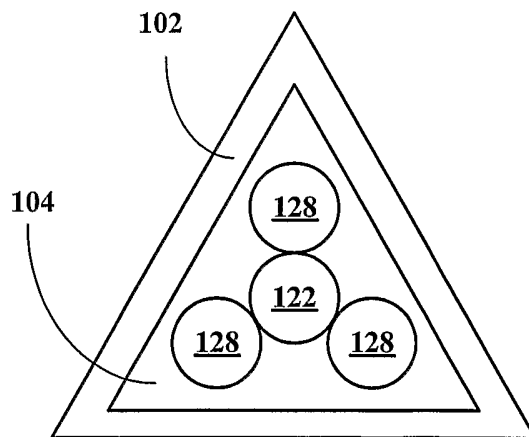

FIG. 1G

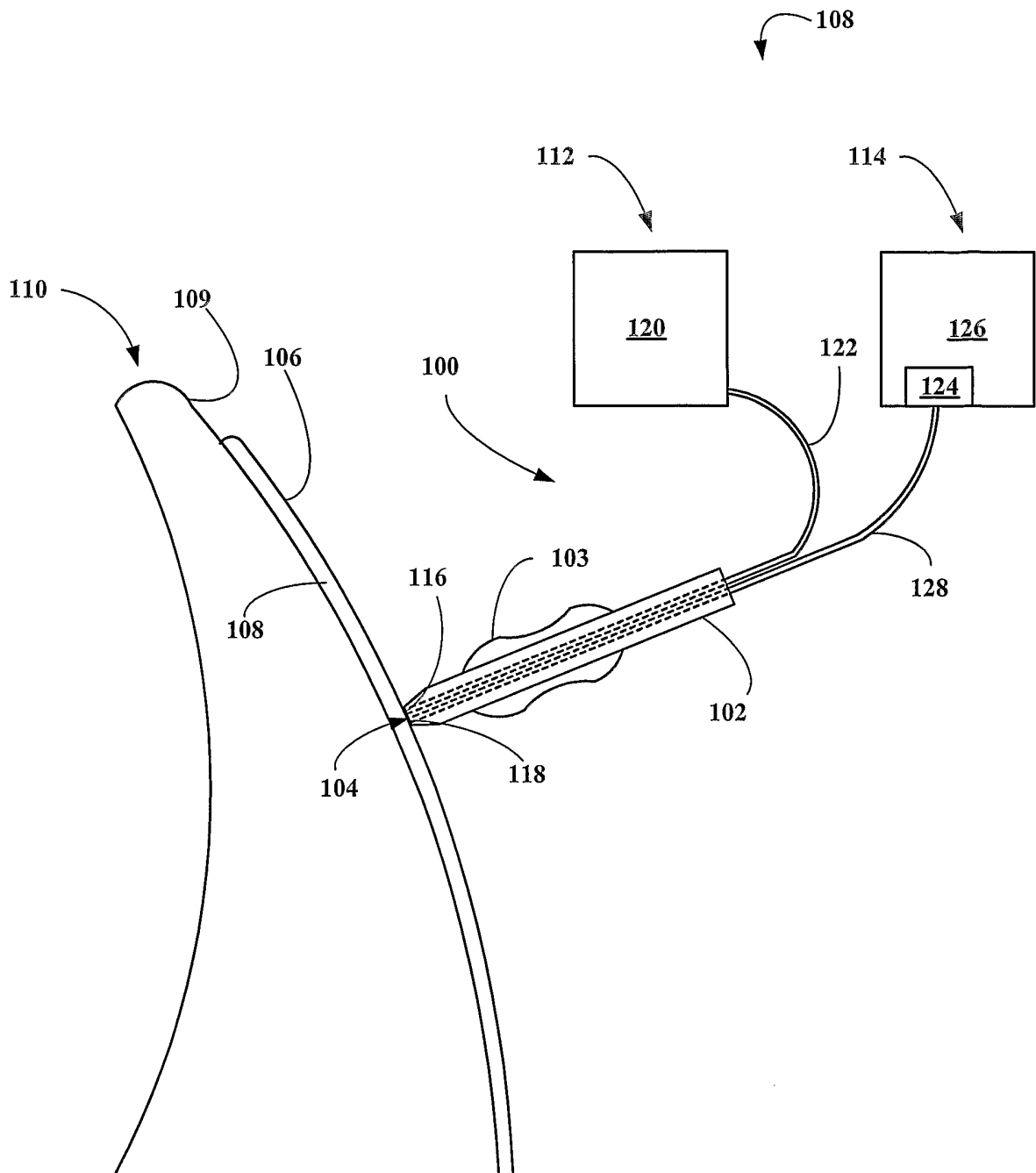

FIG. 1H

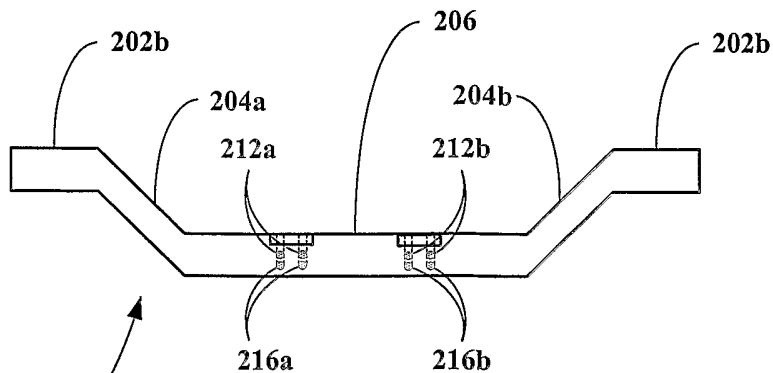

FIG. 2A

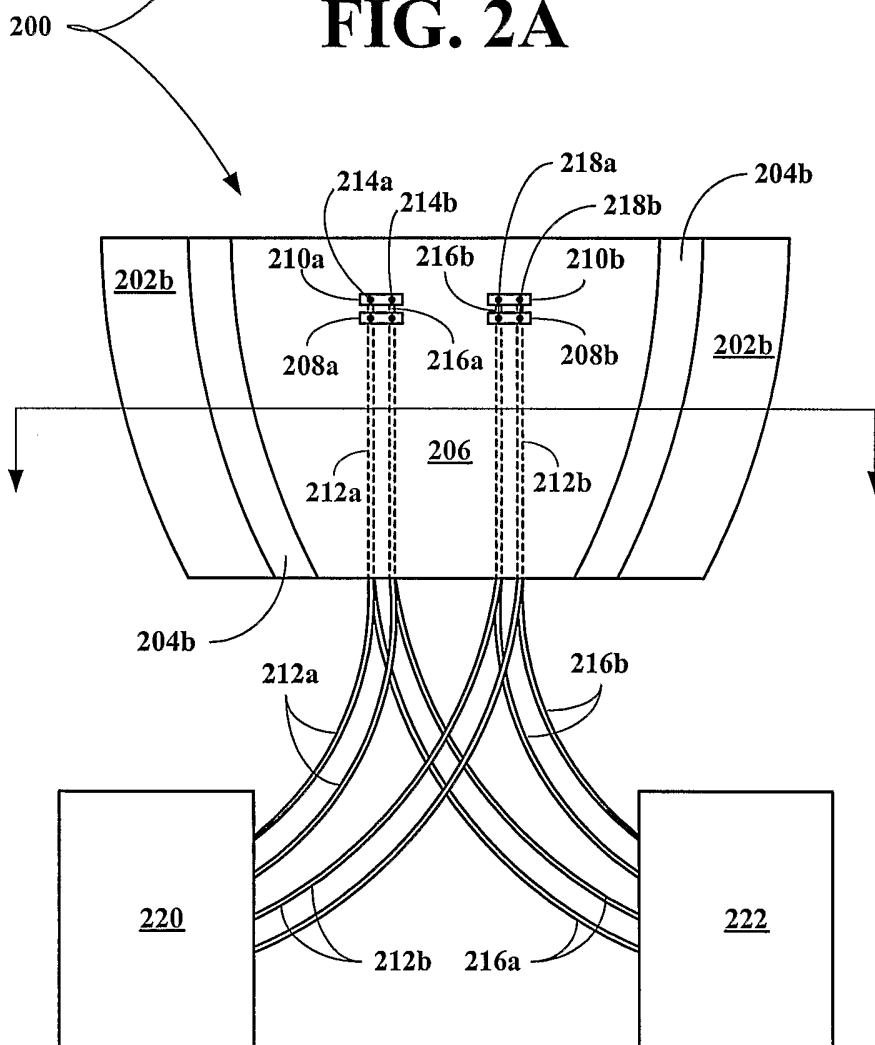

FIG. 2B

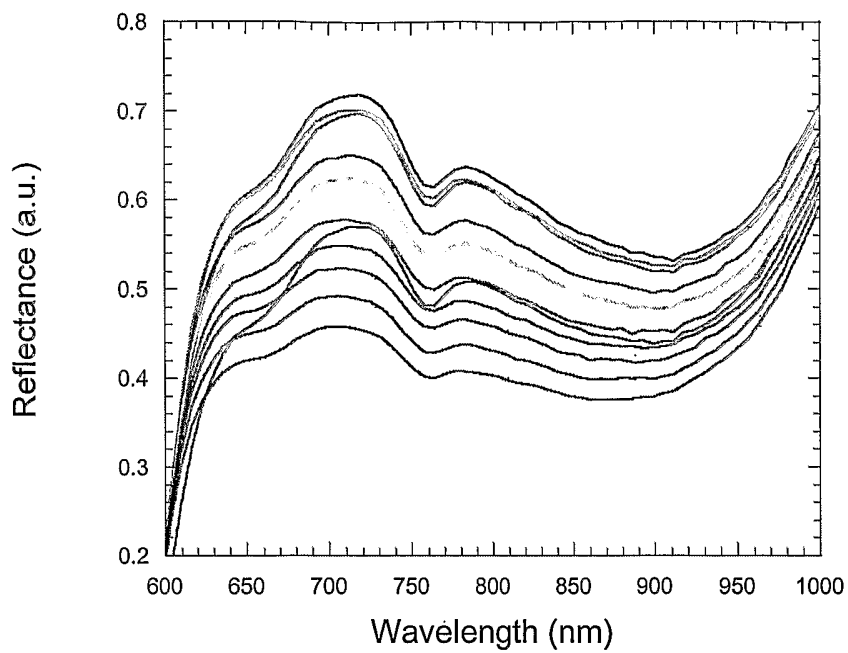

FIG. 3

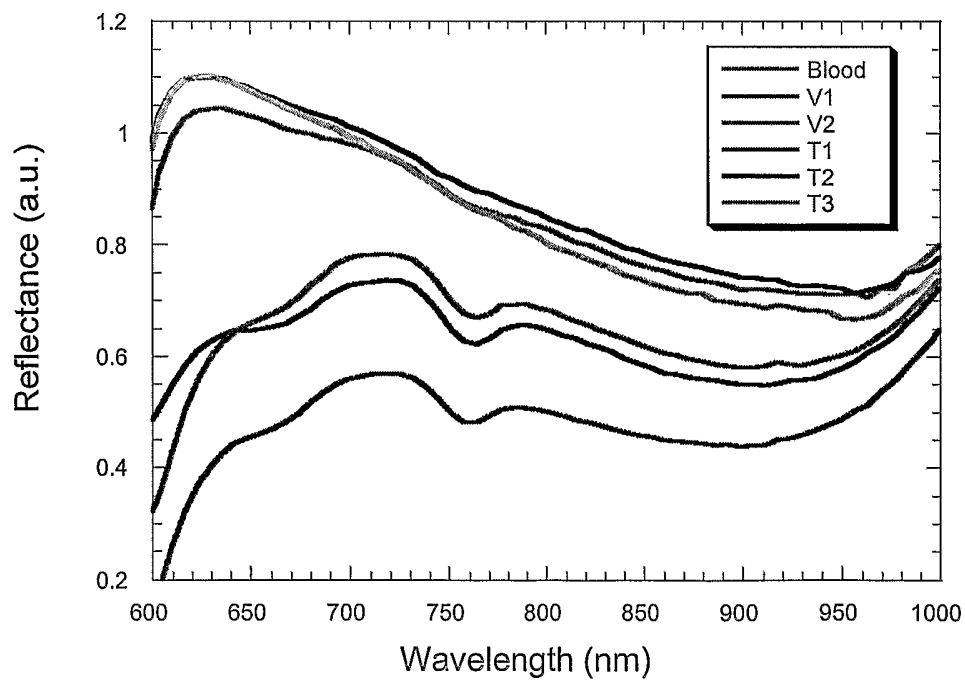

FIG. 4

8/14

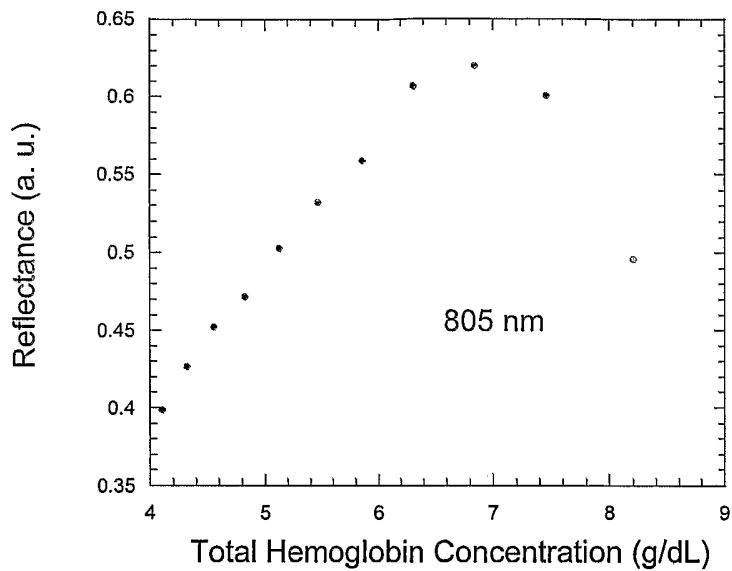

FIG. 5

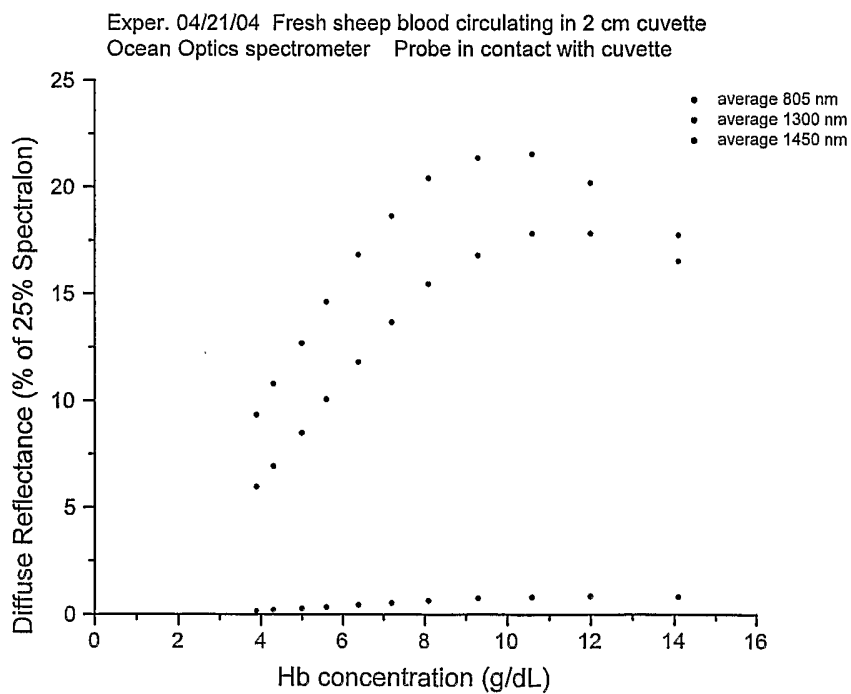

FIG. 6A

9/14

Exper. 04/21/04 Fresh sheep blood circulating in 2 cm cuvette
Ocean Optics spectrometer Probe in contact with cuvette

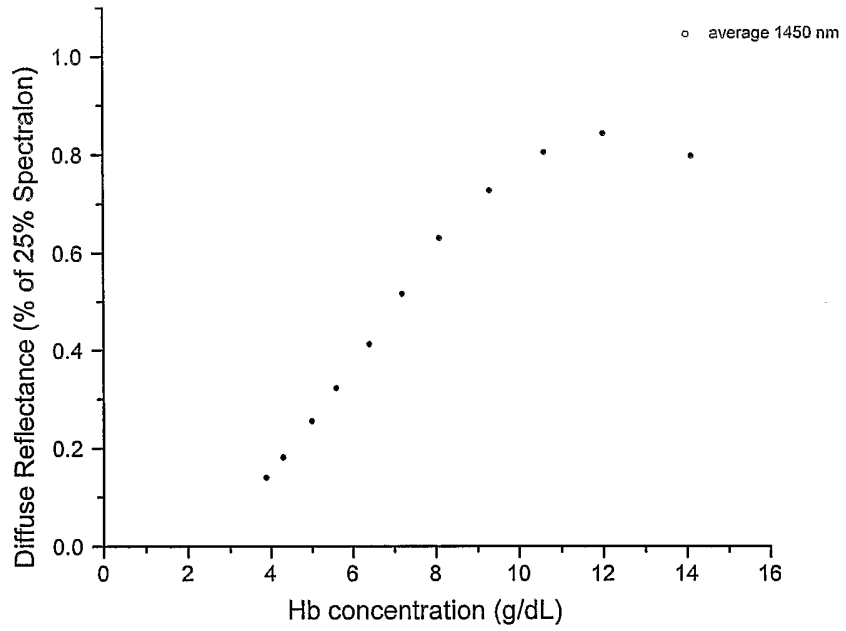

FIG. 6B

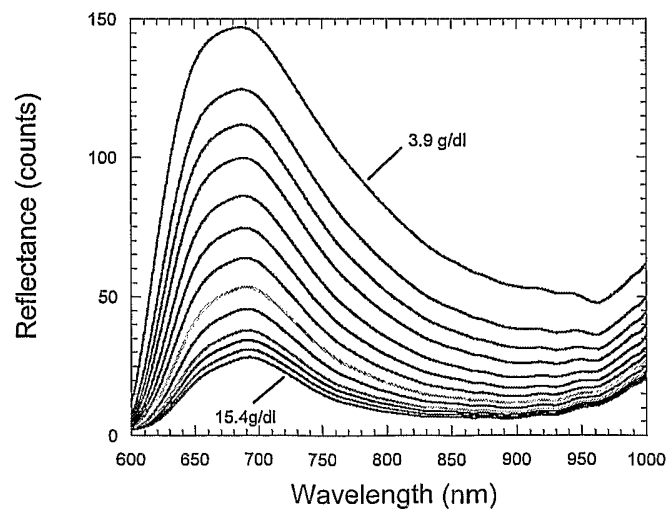

FIG. 7A

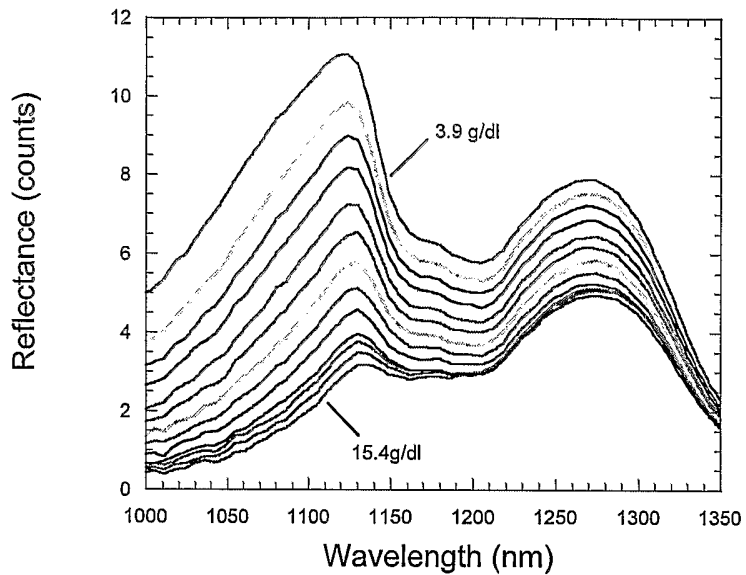

FIG. 7B

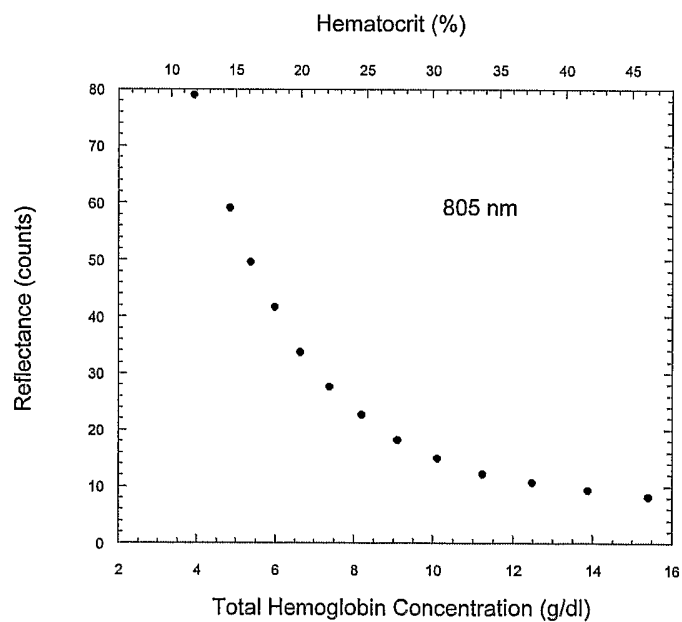

FIG. 8A

11/14

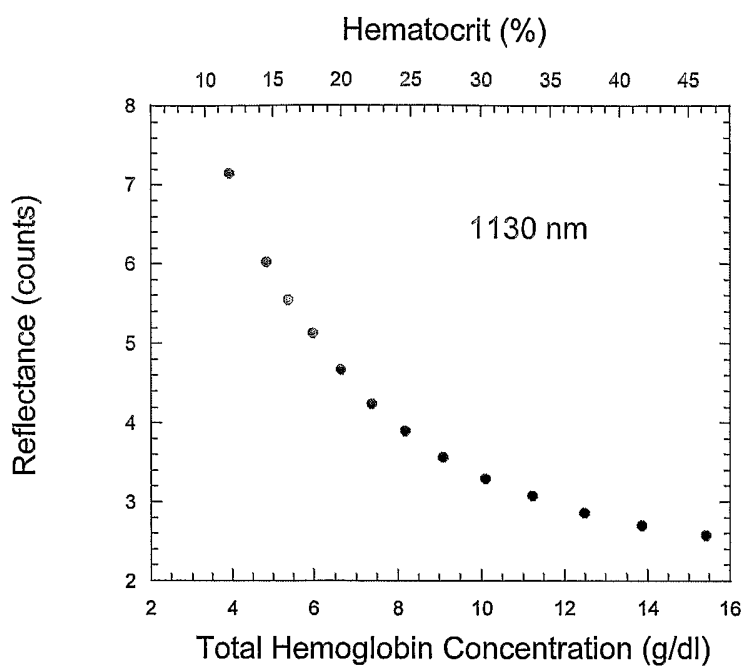

FIG. 8B

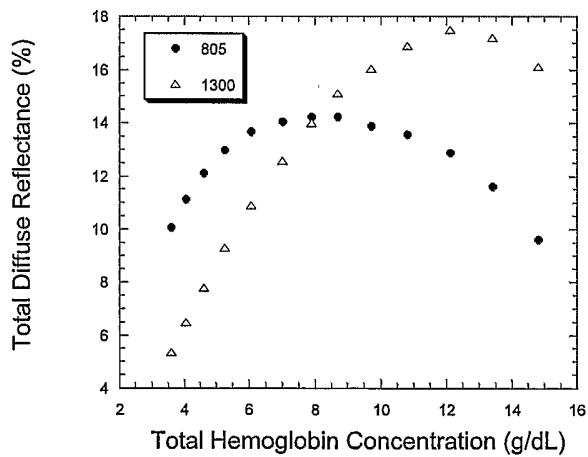

FIG. 9A

12/14

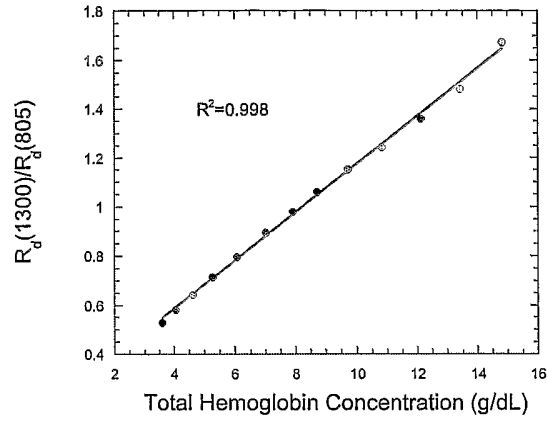

FIG. 9B

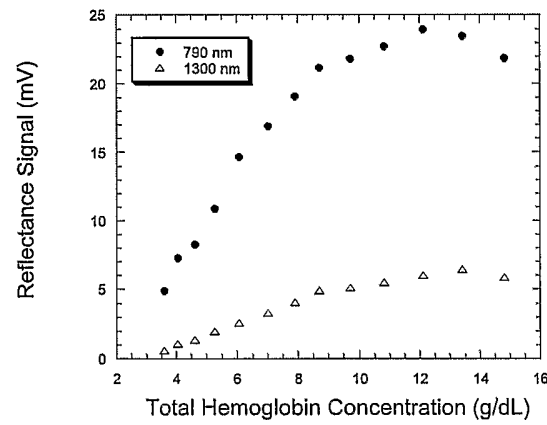

FIG. 10A

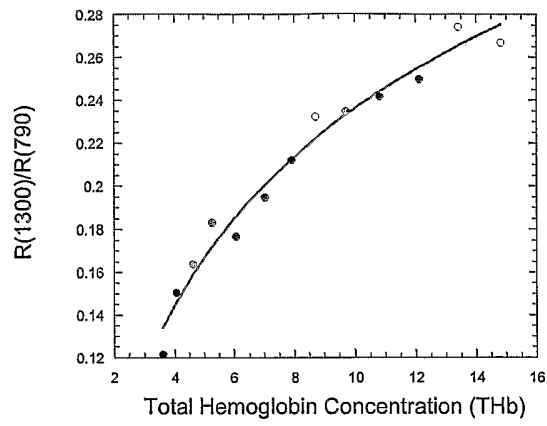

FIG. 10B

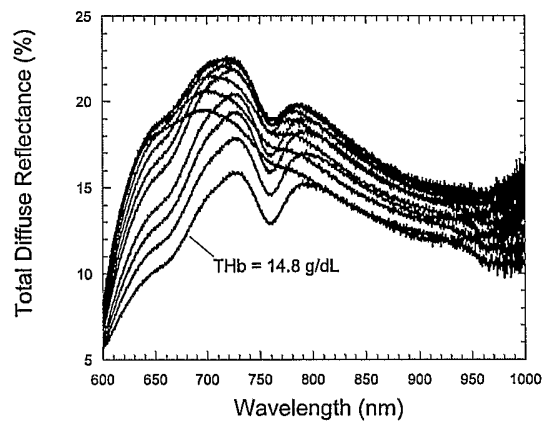

FIG. 11A

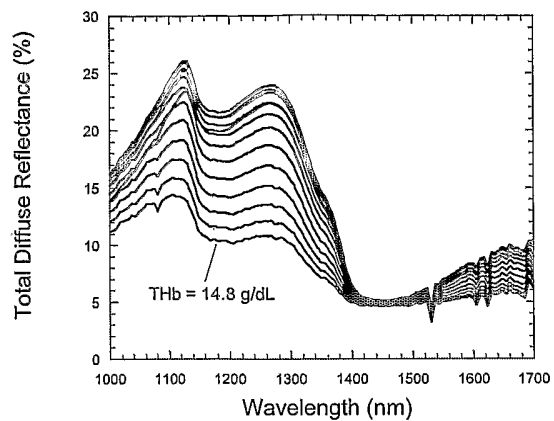

FIG. 11B