



(12) **EUROPEAN PATENT APPLICATION**

(43) Date of publication:
20.02.2002 Bulletin 2002/08

(51) Int Cl.7: **B65D 47/08**, B65D 43/16,
 A47K 10/32

(21) Application number: **00117506.6**

(22) Date of filing: **14.08.2000**

(84) Designated Contracting States:
**AT BE CH CY DE DK ES FI FR GB GR IE IT LI LU
 MC NL PT SE**
 Designated Extension States:
AL LT LV MK RO SI

- **Radtke, Thomas**
 61440 Oberursel (DE)
- **Young, Kenneth**
 61462 Königstein (DE)
- **Sams, Bernard**
 London N11 3EU (GB)
- **Sams, Stephen**
 London N11 3EU (GB)

(71) Applicant: **THE PROCTER & GAMBLE COMPANY**
 Cincinnati, Ohio 45202 (US)

(72) Inventors:
 • **Zethoff, Martin**
 65779 Kelkheim (DE)

(74) Representative: **Kremer, Véronique et al**
Procter & Gamble Service GmbH
 65823 Schwalbach am Taunus (DE)

(54) **Container closure arrangement**

(57) This invention relates to a closure arrangement for closing an opening (17) in a base component (15).

In particular - but not exclusively - this invention relates to a closure arrangement for a container, to serve as an openable lid (17) for the container.

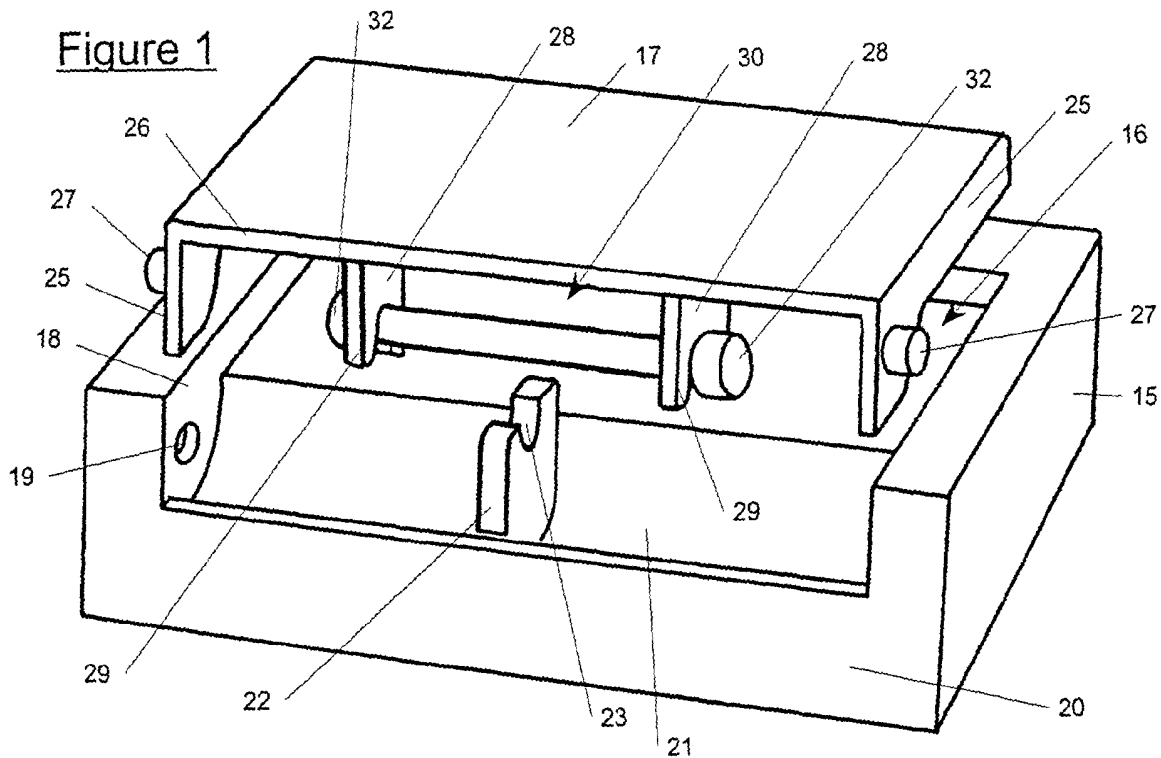

Description

[0001] This invention relates to a closure arrangement for closing an opening in a base component. In particular - but not exclusively - this invention relates to a closure arrangement for a container, to serve as an openable lid for the container.

[0002] Many household products are supplied in a container having an opening to give access to the interior of the container, together with a lid to close that opening. Many such containers require two hands to remove the lid but for some products, it is desirable that the container can be opened simply, just with one hand. For example, in the case of a container for wetted or moist tissues, a person wishing to use a tissue may well have soiled fingers and so will wish to gain access to the interior of the container holding the tissues in a quick and simple manner. On the other hand, the lid for the container, when closed, should substantially seal the container so as to prevent drying-out of the wetted tissues.

[0003] Particularly in the case of a container for wetted tissues, it is advantageous if the lid can be moved from its closed position to its opened position automatically, on being released by a simple one-touch action by a finger of a user. For example, such a container is described in EP-0952088-A.

[0004] It is an aim of the present invention to improve on the several known designs of closure arrangements for containers and so provide such an arrangement which can be operated effectively and reliably for the expected life of the container, and yet which is cheap and easy to manufacture, bearing in mind that the container will probably be thrown away when its contents have been exhausted.

[0005] Accordingly, the present invention provides a closure arrangement comprising a base component defining a closable opening, a closure for the opening and hinged to the base component for movement between closed and open positions, juxtaposed lugs provided respectively on the base component and the closure in the region of the hinging axis of the closure, each lug having at or adjacent its free end a receptor, and an elastic link located in and extending between the receptors of the lugs, the receptors of the lugs being off-set from the hinging axis and arranged such that the link is strained when the closure is at its closed position, the straining of the link varying as the closure is moved between its closed and open positions and is least when the closure is at its open position.

[0006] It will be appreciated that the closure arrangement of this invention may be manufactured by a moulding operation using suitable plastics materials, except perhaps for the elastic link. Both the base component and the closure may be configured to be relatively simple items so as to be cheap to manufacture in large quantities and yet able to give reliable operation when in use.

[0007] Though it would be possible for there to be only one lug on the base component and only one lug on the closure, preferred embodiments of this invention have a single lug on one of the base component and the closure and on the other of the base component and closure a pair of spaced apart lugs so that the single lug is disposed therebetween. For such an arrangement, the elastic link may be strained between the pair of lugs and be deflected from a straight-line path by means of the single lug engaged substantially centrally with the link.

[0008] The elastic link preferably takes the form of a strip of elastomeric material moulded to have an enlarged head at each of its two ends respectively and which heads in use engage the respective lugs. Preferably, the strip of elastomeric material is of substantially circular cross-sectional shape. Each receptor may comprise a generally U-shaped recess formed in an end portion of each lug, which recess has a sufficient width to receive the strip of elastomeric material but the head of the strip serving to prevent the strip pulling out of the receptor transverse to the plane of the lug.

[0009] Preferably, a catch mechanism is provided to maintain the closure in its closed position, against the action of the strained link. Such a catch mechanism may comprise a catch member hinged to the base component and a tab provided on the closure which tab is engageable with the catch member so as to retain the closure in its closed position. Hinging of the catch member away from the tab will then release the closure to permit it to move to its open position, under the action of the elastic link. Such a releasing action may easily be performed by a single finger of a user so facilitating easy access to the contents of a container associated with the closure arrangement.

[0010] In an alternative embodiment, the arrangement of the lugs respectively on the base component and the closure is such that the straining of the elastic link initially increases on moving the closure from its closed position to its open position, before reducing to its smallest value with the closure at its open position. Such a closure arrangement will have an over-centre feel but may still be released easily so as automatically to move to its open position, merely by lifting the closure slightly.

[0011] Preferably, the closure arrangement of this invention is used in association with a container, the base component forming a part of a lid assembly for that container. Such a container may hold wetted or moistened sheets or tissues removable from the container through the opening in the base component. In this case, the closure when in its closed position may effect a generally air-tight seal to the base component, to minimise any drying of the moistened or wetted sheets within the container.

[0012] By way of example, certain specific embodiments of this invention will now be described in detail, reference being made to the accompanying drawings in which:-

Figure 1 is an isometric rear view of a first closure arrangement, with the closure separated from the base component;

Figure 2 is a view similar to that of Figure 1 but with the closure fitted to the base component;

Figure 3 is a sectional view through the arrangement of Figures 1 and 2 taken generally on the hinging axis of the closure;

Figures 4, 5 and 6 correspond to Figures 1, 2 and 3 respectively, but showing a second embodiment;

Figure 7 corresponds generally to Figure 2, but shows a third embodiment of this invention;

Figure 8 shows a catch mechanism used with the first, second and third embodiments of this invention;

Figures 9A, 9B and 9C are cross-sections through the hinge region of the embodiment of Figures 1 to 3; and

Figure 10 is a view similar to that of Figure 9A, but of an alternative over-centre arrangement.

[0013] Referring initially to Figures 1 to 3, there is shown a first embodiment of closure arrangement of this invention and comprising a base component 15 defining an opening 16, and a closure 17 pivoted to the base component 15 for movement between an open position and a closed position (shown in Figure 2) where the closure closes the opening 16. Both the base component 15 and the closure 17 are moulded from a plastics material. The lower region of the base component 15 may be configured for mounting on a lid of a container, over an aperture through that lid. In the alternative, the base component 15 may itself form the lid for a container with which the closure arrangement is to be associated. Yet another possibility would be for the base component 15 to be formed integrally with or attached directly to a container.

[0014] Around three sides of the opening 16, the base component 15 is provided with an in-turned flange 18, that flange on the two sides having aligned holes 19, adjacent the rear wall 20 of the base component 15. A curved wall 21 extends inwardly of the opening 16 from the rear wall 20, curving upwardly towards the top face of the base component 15. A lug 22 projects upwardly from this curved wall 21, midway along the length of the rear wall 20, the lug 22 having a U-shaped slot 23 at its upper free end.

[0015] The closure 17 is of simple rectangular shape and is provided with a downturned lip 25 around its periphery. For the sake of clarity, the lip has been omitted from the rear edge 26 of the closure in Figures 1 and 2,

but is shown in Figure 9A, 9B and 9C, and has a curved form for interaction with the rear wall as the closure is opened. The closure 17 is dimensioned so that it is a snug fit within the opening 16 of the base component 15, when in its closed position shown in Figure 2, giving a generally moisture-tight seal.

[0016] Projecting outwardly from the lip 25 at two opposed locations adjacent the rear edge 26 of the closure 17 are aligned pivot pins 27, arranged to be received in the aligned holes 19 of the base component 15, so allowing the closure 17 to pivot between the closed position shown in Figure 2 to an open position shown in Figure 9C. The under-surface of the closure 17 is provided with a pair of spaced lugs 28, disposed equidistant from the side edges of the closure and each having a U-shaped slot 29 formed in its free end. Stretched between the lugs 28 is a link 30 of an elastomeric material (such as natural or synthetic rubber), the link 30 having a main portion 31 of circular cross-sectional shape and a respective head 32 formed at each of the two ends of the main portion 31. As shown in Figure 1, the link 30 should be lightly stretched when positioned between the pair of lugs 28 on the closure, so that the link will remain in position in the slots 29 by virtue of the tension in the link. Then, on engaging the pivot pins 27 with the holes 19, as shown in Figure 2 and 3, the lug 22 on the base component 15 will engage the central part of the link 30 and strain that link so as to take up a generally V-shaped form.

[0017] With the closure 17 in its closed position, shown in Figures 2, 3 and 9A, the link 30 is strained to the greatest extent. Pivoting movement of the closure 17 from its closed position through an intermediate position (Figure 9B) to its open position (Figure 9C) reduces the straining of the link, with the included angle of the V-shaped form taken up by the main portion 31 of the link 30 reducing as the closure moves to its open position. Thus, the closure 17 will tend to move to its open position where the tension in the link 30 is at a minimum.

[0018] In Figure 3, two retaining walls 33 are shown, disposed outside the pair of lugs 28 and spaced therefrom. These walls serve to assist holding of the link 30 in the slots 29 of lugs 28, by having each head 32 of the link a friction fit between the wall 33 and the opposed face of the link. These walls may be omitted, as shown in Figures 1 and 2, if the link is sufficiently strained when carried in the pair of lugs 29, before the closure is engaged with the base member.

[0019] In order to maintain the closure 17 in its closed position, a catch mechanism 34 as shown in Figure 8 is employed. This catch mechanism includes an L-shaped catch member 35 which is pivoted at 36 to the base component 15, so as to be movable between a holding position shown in solid lines in Figure 8 and a released position shown in broken lines in that Figure. The closure 17 is shown diagrammatically at 37 in Figure 8, but in the arrangement of Figures 1 and 2, there is a forwardly-projecting tab (not shown) on the closure 17 and

below the upper surface of that closure, so that the upper surface 38 of the catch member 35 may lie in substantially the same plane as the upper surface of the closure 17.

[0020] Though in Figure 8 a simple pivot 36 is shown for the catch member 35, preferably the pivot is defined by a moulded film hinge which will urge the catch member to its holding position, movement of the catch member to its released position being against the force provided by the film hinge. The forward edge 39 of the catch member should be raked as shown in Figure 8, so as to permit the closure 17 (or the tab provided thereon) to ride over that edge 39, deflecting the catch member 35 as necessary. Securing of the closure 17 in its closed position thus simply requires the closure to be pushed to that position. Then, the closure may be released by a simple one-touch operation, pressing on the upper surface of the catch member 35.

[0021] Figures 4, 5 and 6 show a second embodiment of this invention but which is generally similar to the arrangement of Figures 1 to 3. Consequently, like parts are given like reference numerals and those parts will not be described again here.

[0022] The second embodiment of Figures 4 to 6 differs from that of Figures 1 to 3 in that the closure 17 is provided with only a single downwardly-projecting lug 40, disposed centrally of the closure adjacent its rear edge 26. Conversely, the base component 15 has a pair of spaced lugs 41 the upper edges of which are on the same level as the upper edge of the curved wall 21. In this embodiment, the elastic link 30 is strained between the lugs 41 and the lug 40 on the closure engages a central region of the main portion 31 of that link, to deform the link into a generally V-shaped form when the closure is in its closed position, as shown in Figures 5 and 6. In other respects, the embodiment of Figures 4 to 6 operates as has been described above with reference to Figures 1 to 3.

[0023] Figure 7 shows a third embodiment of this invention. In this embodiment, the base component 43 has a generally rounded profile to enhance the aesthetic appearance thereof, as compared to the base component 15, but otherwise generally corresponds to that base component 15. However, in this embodiment both the base component 43 and the closure 17 are provided only with one lug 44 and 45 each, those lugs being disposed equally to either side of the centre line of the closure 17. A shorter elastic link 46 is provided than in the case of the embodiments of Figures 1 to 6, but the link is generally of the same form as link 30 and operates in the same manner. In other respects, the embodiment of Figure 7 is essentially the same as the first two embodiments, described above.

[0024] It will be appreciated that with the embodiments of Figures 1 to 7, the axis of pivoting movement of the closure 17 (that is, the axis of the holes 19 and pivot pins 27) is disposed slightly to the rear of the slots in the lugs of the closure and base component, as shown

in Figure 9A. This ensures that the link is strained to its greatest extent when the closure is in its closed position, with the straining of the link reducing as the closure is moved to its open position. The position of said axis relative to the lugs may be adjusted to control the rate of change of the force of the link. If that axis is moved sufficiently forwardly to lie just in front of the link with the closure in its closed position, there will be imparted to the mechanism an over-centre (or toggle) action; such an arrangement is shown in Figure 10. With this arrangement, the straining of the link increases for the first few degrees of opening movement of the closure, whereafter the action proceeds as described above, with the straining reducing until the closure is in its opened position. The result is that the closed position of the closure is stable and the closure will move automatically to its open position only after raising the closure through a few degrees. This then permits the elimination of the catch mechanism 34 whilst still giving a simple and easy to operate one-touch action, of just raising the closure by a few degrees at its forward edge.

Claims

1. A closure arrangement comprising a base component defining a closable opening, a closure for the opening and hinged to the base component for movement between closed and open positions, juxtaposed lugs provided respectively on the base component and the closure in the region of the hinging axis of the closure, each lug having at or adjacent its free end a receptor, and an elastic link located in and extending between the receptors of the lugs, the receptors of the lugs being off-set from the hinging axis and arranged such that the link is strained when the closure is at its closed position, the straining of the link varying as the closure is moved between its closed and open positions and is least when the closure is at its open position.
2. A closure arrangement as claimed in claim 1, wherein the base component is provided with a pair of similarly-configured lugs spaced in the direction of the hinging axis of the closure, the elastic link extends between the pair of lugs and is located in the receptors thereof, and the lug of the closure is disposed between the pair of lugs of the base component with the closure lug receptor also engaging the elastic link.
3. A closure arrangement as claimed in claim 1, wherein the closure is provided with a pair of similarly-configured lugs spaced in the direction of the hinging axis of the closure, the elastic link extends between the pair of lugs and is located in the receptors thereof, and the lug of the base component is disposed between the pair of lugs of the closure with

the base component lug receptor also engaging the elastic link.

4. A closure arrangement as claimed in any of the preceding claims, wherein each receptor comprises a generally U-shaped slot formed in an end portion of each lug. 5

5. A closure arrangement as claimed in any of the preceding claims, wherein the elastic link comprises a strip of elastomeric material moulded to have enlarged heads at its two ends and which heads engage the lugs. 10

6. A closure arrangement as claimed in claim 5, wherein the strip of elastomeric material is of substantially circular cross-sectional shape. 15

7. A closure arrangement as claimed in any of the preceding claims, wherein a catch mechanism is provided to maintain the closure in its closed position. 20

8. A closure arrangement as claimed in claim 7, wherein said catch mechanism comprises a catch member hinged to the base component and a tab provided on the closure which tab is engageable with the catch member to retain the closure in its closed position. 25

9. A closure arrangement as claimed in any of the preceding claims, wherein the arrangement of the lugs respectively on the base component and the closure is such that the strain in the elastic link initially increases on moving the closure from its closed position to its open position, before reducing to its smallest value with the closure at its open position. 30
35

10. A closure arrangement as claimed in any of the preceding claims, wherein the base component forms a part of a lid assembly for a container. 40

11. A closure arrangement for a container as claimed in claim 10 and where the container is intended to hold wetted or moistened sheets removable from the container through the opening in the base component, wherein the closure when in its closed position effects a generally moisture-tight seal to the base component. 45

12. A closure arrangement as claimed in claim 1 and substantially as hereinbefore described with reference to and as illustrated in the accompanying drawings. 50

55

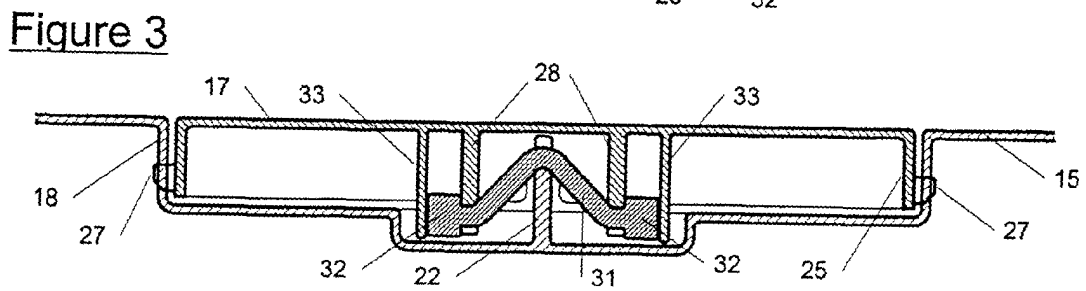
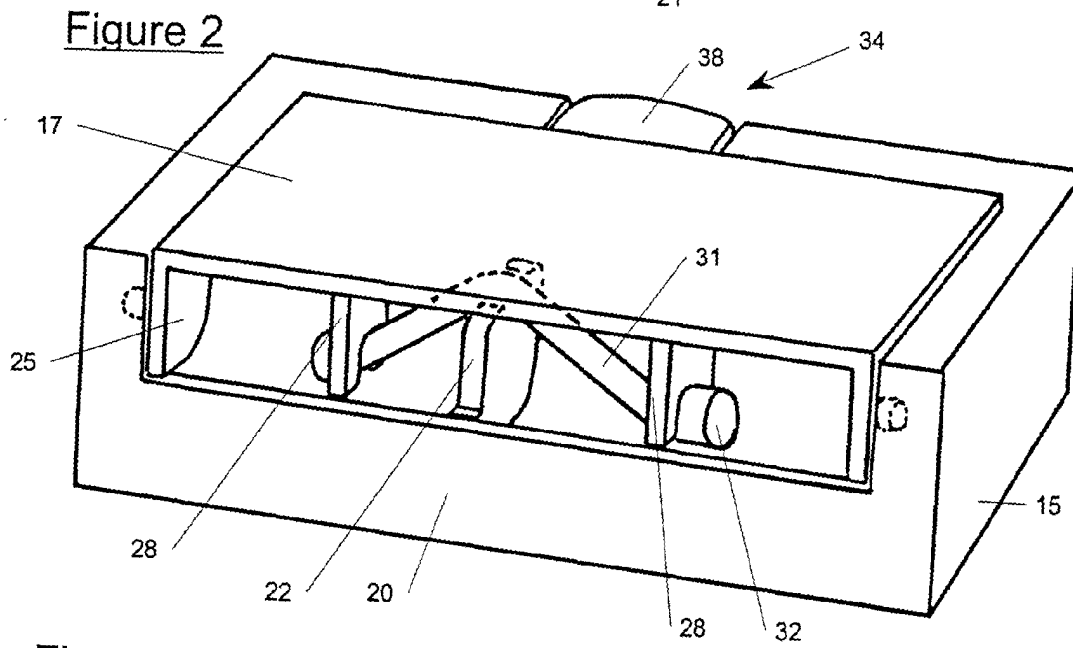
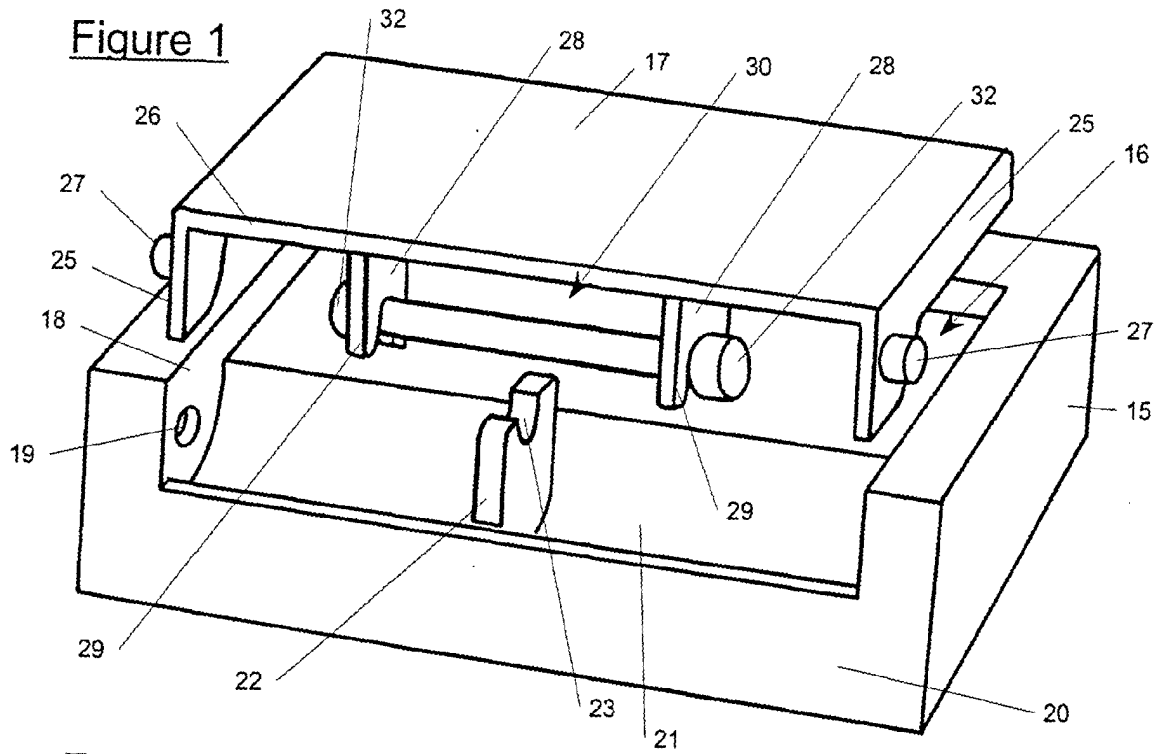

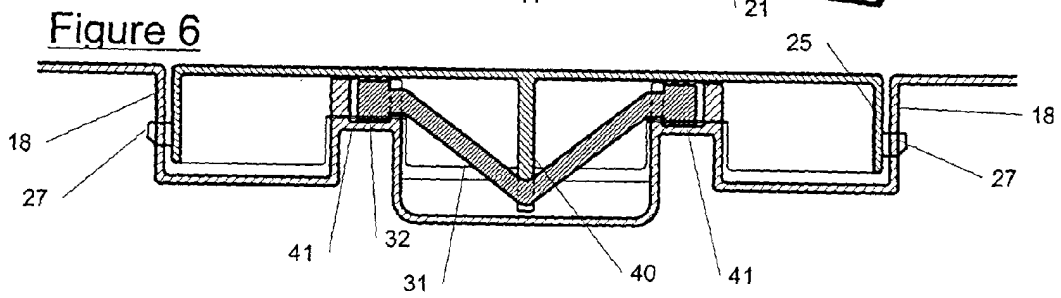
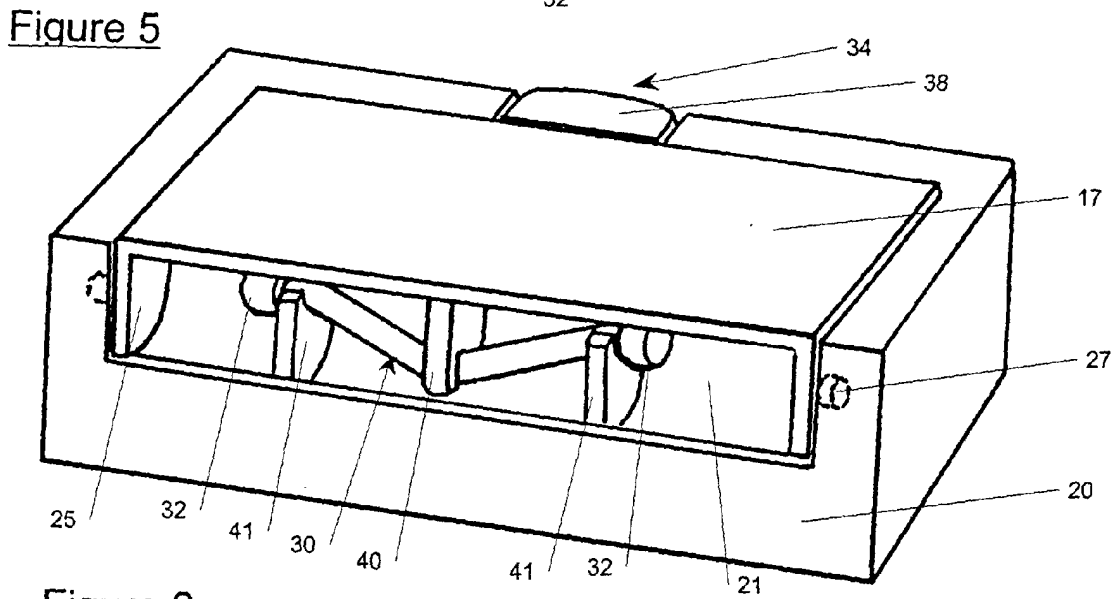
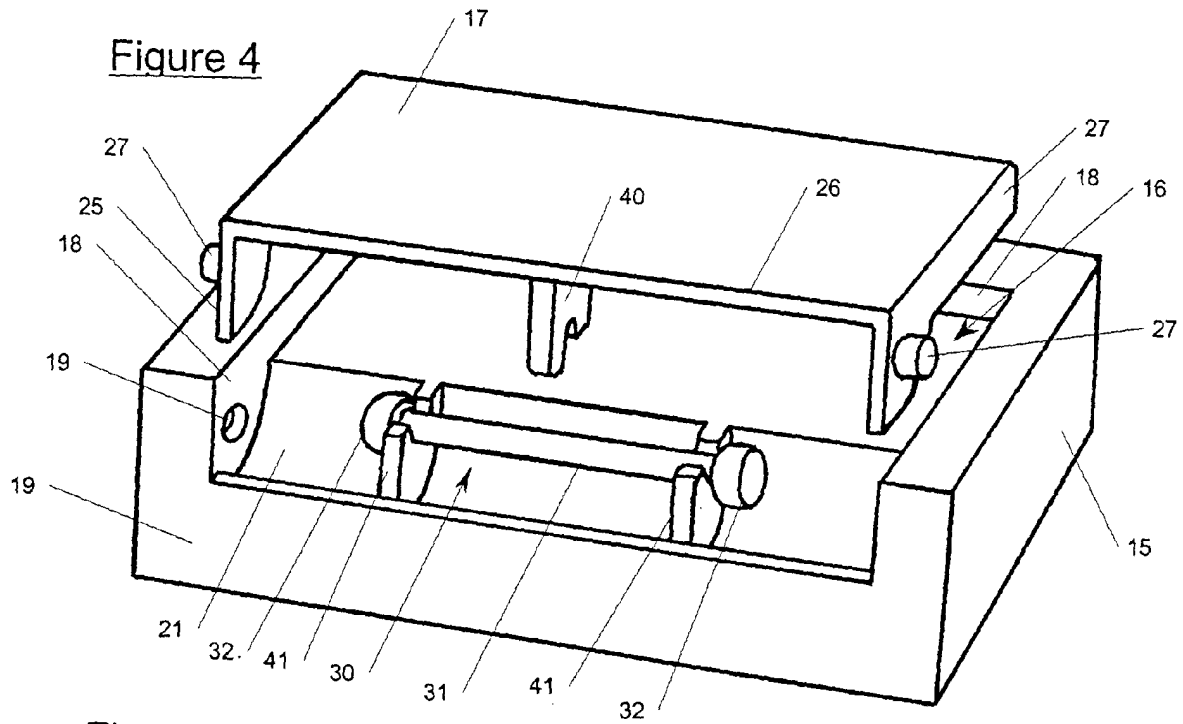

Figure 7

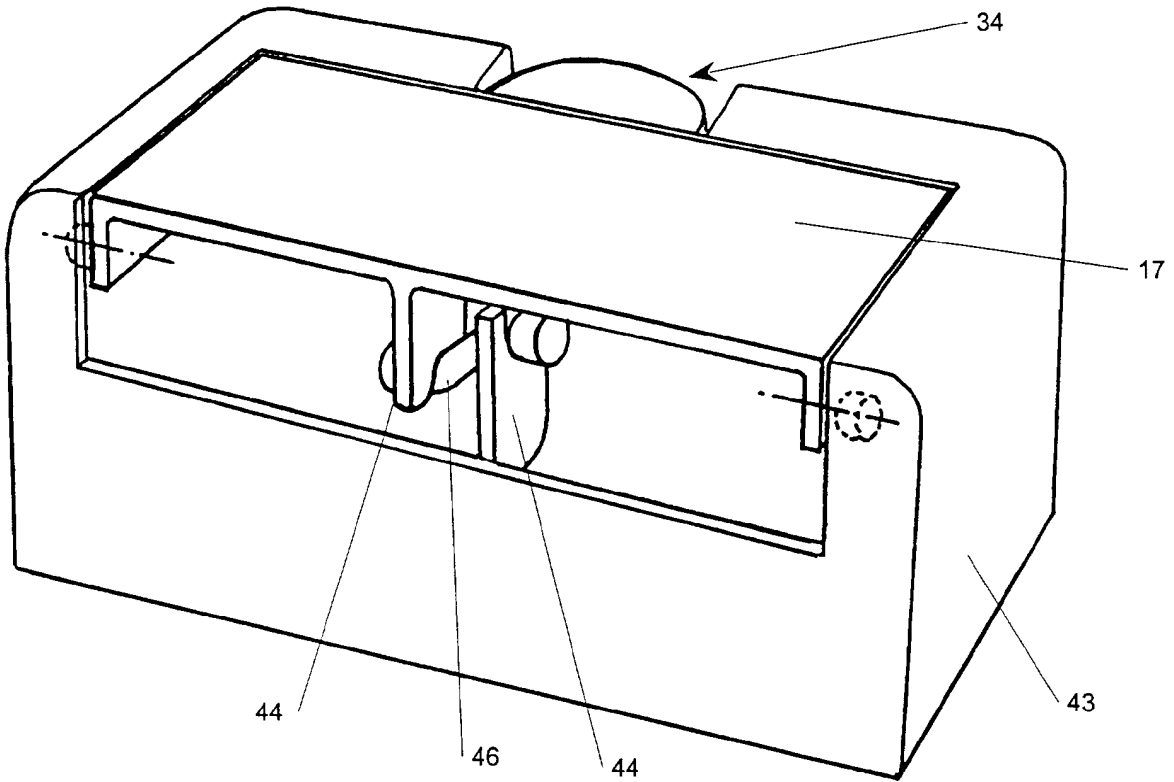

Figure 8

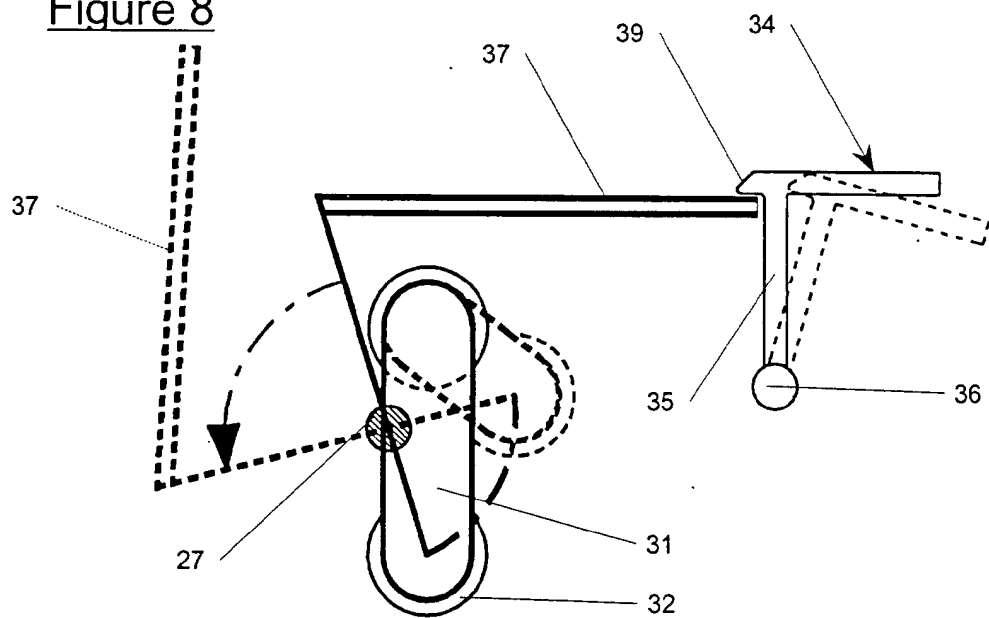

Figure 9A

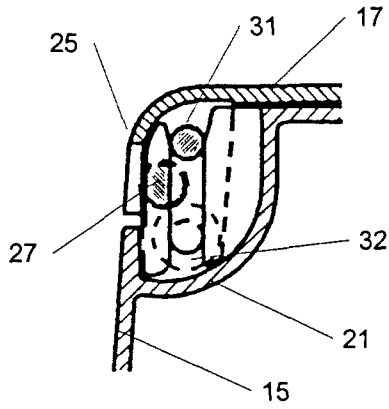

Figure 9B

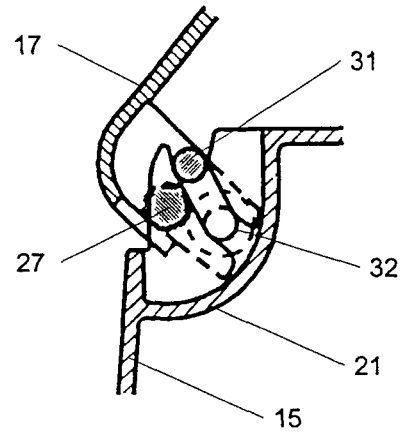

Figure 9C

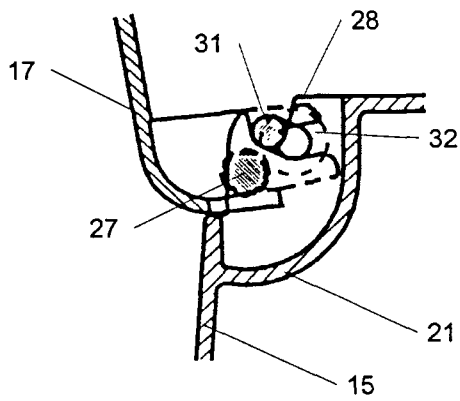
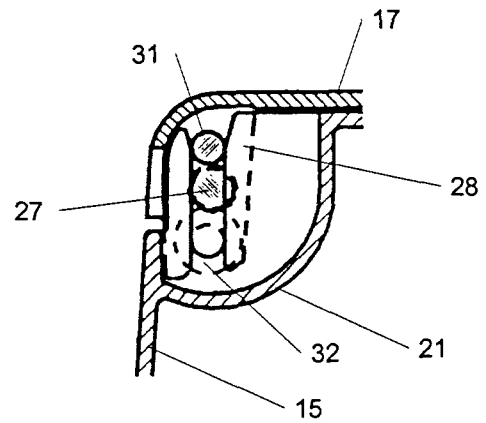

Figure 10





European Patent
Office

EUROPEAN SEARCH REPORT

Application Number
EP 00 11 7506

DOCUMENTS CONSIDERED TO BE RELEVANT

Category	Citation of document with indication, where appropriate, of relevant passages	Relevant to claim	CLASSIFICATION OF THE APPLICATION (Int.Cl.7)
A	EP 0 608 757 A (GROSSHANS JUERGEN) 3 August 1994 (1994-08-03) * column 2, line 1 - column 4, line 49 * * column 6, line 1 - line 17 * * claims 1,2,4,5 * * figures 1-12 *	1-3,9	B65D47/08 B65D43/16 A47K10/32
A	US 5 699 912 A (KENMOCHI YASUHIKO ET AL) 23 December 1997 (1997-12-23) * column 1, line 40 - column 3, line 10 * * column 5, line 37 - line 52 * * column 7, line 6 - line 35 * * claims 1,3-5,7,11-13 * * figures 2,3B,3C,6-8,9A,9B,10A-10C,11A-11C,21A,21B *	1,4,7-11	
A	DE 195 17 102 A (ZELLER PLASTIK KOEHN GRAEBNER) 14 November 1996 (1996-11-14) * column 1, line 55 - column 3, line 38 * * claims 1,4,11 * * figures 1-10 *	1,4,5	
A	EP 0 953 313 A (PROCTER & GAMBLE) 3 November 1999 (1999-11-03) * column 2, line 20 - line 39 * * column 5, line 19 - column 6, line 29 * * claims 1,3,6-9 * * figures 1-4 *	1,4,5,7,9-11	B65D A47K A45C
The present search report has been drawn up for all claims			
Place of search BERLIN		Date of completion of the search 15 January 2001	Examiner Schultz, O
CATEGORY OF CITED DOCUMENTS X : particularly relevant if taken alone Y : particularly relevant if combined with another document of the same category A : technological background O : non-written disclosure P : intermediate document		T : theory or principle underlying the invention E : earlier patent document, but published on, or after the filing date D : document cited in the application L : document cited for other reasons & : member of the same patent family, corresponding document	

EPO FORM 1503 03.82 (P04001)

**ANNEX TO THE EUROPEAN SEARCH REPORT
ON EUROPEAN PATENT APPLICATION NO.**

EP 00 11 7506

This annex lists the patent family members relating to the patent documents cited in the above-mentioned European search report. The members are as contained in the European Patent Office EDP file on
The European Patent Office is in no way liable for these particulars which are merely given for the purpose of information.

15-01-2001

Patent document cited in search report		Publication date	Patent family member(s)	Publication date
EP 0608757	A	03-08-1994	DE 4302398 C DE 9316449 U	21-04-1994 20-01-1994
US 5699912	A	23-12-1997	JP 9058725 A AU 709893 B AU 5596896 A CA 2178999 A CN 1151962 A DE 69608495 D DE 69608495 T EP 0748748 A KR 195599 B SG 45488 A	04-03-1997 09-09-1999 02-01-1997 16-12-1996 18-06-1997 29-06-2000 26-10-2000 18-12-1996 15-06-1999 16-01-1998
DE 19517102	A	14-11-1996	NONE	
EP 0953313	A	03-11-1999	AU 3163899 A WO 9955213 A	16-11-1999 04-11-1999

EPO FORM P0459

For more details about this annex : see Official Journal of the European Patent Office, No. 12/82