

(19) World Intellectual Property  
Organization  
International Bureau



(43) International Publication Date  
29 September 2005 (29.09.2005)

PCT

(10) International Publication Number  
**WO 2005/089619 A1**

(51) International Patent Classification<sup>7</sup>: **A47L 13/142**,  
13/146

(21) International Application Number:  
PCT/US2005/009320

(22) International Filing Date: 17 March 2005 (17.03.2005)

(25) Filing Language: English

(26) Publication Language: English

(30) Priority Data:  
60/554,122 18 March 2004 (18.03.2004) US  
11/081,916 16 March 2005 (16.03.2005) US

(71) Applicant and

(72) Inventor: **PERKITNY, Jerzy** [US/US]; 17810 Lake  
Road, Lakewood, OH 44107 (US).

(74) Agents: **MOLDOVANYI, Jay, E.** et al.; Fay, Sharpe, Fa-  
gan, Minnich & McKee, LLP, 1100 Superior Avenue, Sev-  
enth Floor, Cleveland, OH 44114 (US).

(81) Designated States (unless otherwise indicated, for every  
kind of national protection available): AE, AG, AL, AM,  
AT, AU, AZ, BA, BB, BG, BR, BW, BY, BZ, CA, CH, CN,  
CO, CR, CU, CZ, DE, DK, DM, DZ, EC, EE, EG, ES, FI,  
GB, GD, GE, GH, GM, HR, HU, ID, IL, IN, IS, JP, KE,  
KG, KP, KR, KZ, LC, LK, LR, LS, LT, LU, LV, MA, MD,  
MG, MK, MN, MW, MX, MZ, NA, NI, NO, NZ, OM, PG,  
PH, PL, PT, RO, RU, SC, SD, SE, SG, SK, SL, SM, SY, TJ,  
TM, TN, TR, TT, TZ, UA, UG, US, UZ, VC, VN, YU, ZA,  
ZM, ZW.

(84) Designated States (unless otherwise indicated, for every  
kind of regional protection available): ARIPO (BW, GH,  
GM, KE, LS, MW, MZ, NA, SD, SL, SZ, TZ, UG, ZM,  
ZW), Eurasian (AM, AZ, BY, KG, KZ, MD, RU, TJ, TM),  
European (AT, BE, BG, CH, CY, CZ, DE, DK, EE, ES, FI,  
FR, GB, GR, HU, IE, IS, IT, LT, LU, MC, NL, PL, PT, RO,  
SE, SI, SK, TR), OAPI (BF, BJ, CF, CG, CI, CM, GA, GN,  
GQ, GW, ML, MR, NE, SN, TD, TG).

**Published:**

— with international search report

For two-letter codes and other abbreviations, refer to the "Guid-  
ance Notes on Codes and Abbreviations" appearing at the begin-  
ning of each regular issue of the PCT Gazette.

(54) Title: MOP WITH MOTORIZED WRINGING DEVICE

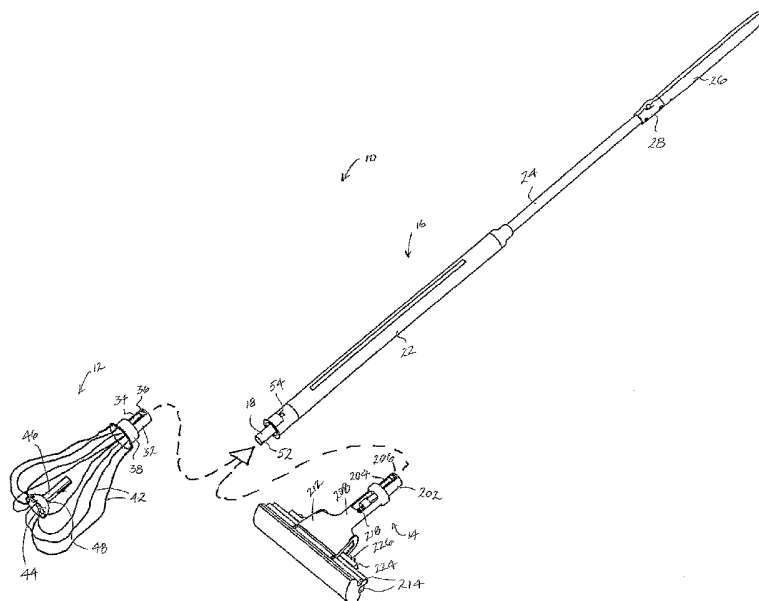

(57) Abstract: A mop (10) includes an elongated handle portion (16), a movable member (22) slidably mounted on the handle portion, a rotary motor (84) disposed in at least one of the elongated handle portion and the movable member, a controller (106) in electrical communication with the motor and an associated power source (152), and a mop head (12, 14). The controller regulates power to the motor as a function of a number or rotations of the motor. The mop head (12, 14) is detachably connected to at least one of the elongated handle portion (16) and the movable member (22). The mop head is selectively connected to the motor.



WO 2005/089619 A1

## MOP WITH MOTORIZED WRINGING DEVICE

**[0001]** This application claims the benefit of U.S. Provisional Patent Application Serial No. 60/554,122, which is herein incorporated by reference.

## BACKGROUND

**[0002]** Mops are used to clean floors as well as other surfaces. When mopping a floor, the head of the mop can become very dirty. Both rinsing and wringing of the mop head are required during the mopping of the floor or surface. It is desirable to provide a mop that has a head that can be wrung out without requiring the user of the mop to touch the dirty mop head.

**[0003]** Power wringer mops are known. Once such mop includes a reversible motor that rotates a socket shaft. The socket shaft includes a receptor or opening at its bottom. A first end of a mop head is received in the opening of the socket shaft and a second end of the mop head is sandwiched between a clamp and the base of the handle. To wring the mop, the motor rotates the motor shaft which rotates the socket shaft and the first end of the mop rotates.

## SUMMARY

**[0004]** A mop includes an elongated handle portion, a movable member slidably mounted on the handle portion, a rotary motor disposed in at least one of the elongated handle portion and the movable member, a controller in electrical communication with the motor and an associated power source, and a mop head. The controller regulates power to the motor as a function of a number of rotations of the motor. The mop head is detachably connected to at least one of the elongated handle portion and the movable member. The mop head is selectively connected to the motor.

**[0005]** A self-wringing mop includes an elongated handle, a movable member slidably connected to the handle, an electric reversible motor disposed in at least one of the handle and the movable member, a mop head attached to the elongated handle and the movable member, and a switch element in electrical communication with the motor and an associated power

source. The mop head is operably connected to the motor. The mop head is movable between a use position and a wringing position by sliding movement of the movable member. The switch element comprises a first switch for delivering current to the motor in a first direction and a second switch for delivering current to the motor in a second, opposite, direction.

**[0006]** A self-wringing mop includes a handle, a slidable member slidably connected to the handle, a rotating member connected to the handle, a mop head connected to the slidable member and the rotating member, a motor operably connected to the rotating member, a power source compartment disposed in at least one of the handle portion and the slidable member, and a limit switch in electrical communication with the motor and the power source compartment. The mop head is connected to the rotating member and includes an absorbent material. The motor drives the rotating member which moves the absorbent material between a wrung and an unwrung position. The limit switch opens in response to the position of the absorbent material.

#### BRIEF DESCRIPTION OF THE FIGURES

**[0007]** A mop will take form in certain parts and arrangements of parts, embodiments of which will be described in detail in this specification and illustrated in the accompanying drawings which form a part hereof and wherein:

**[0008]** FIGURE 1 is a partially exploded view of a motorized mop showing a strand mop head and a sponge mop head removed from a handle portion.

**[0009]** FIGURE 2 is a perspective view of the motorized mop of Figure 1 having a strand mop head mounted thereto where the mop head is in a first or mopping ready position.

**[0010]** FIGURE 3 is a perspective view of the motorized mop of Figure 1 having a strand mop head mounted thereto where the mop head is in a second or wringing ready position.

**[0011]** FIGURE 4a is a side view of the mop of Figure 2 in a third or wrung position with strands of the mop head wound around a front tube of the mop.

**[0012]** FIGURE 4b is a side view of the mop of Figure 2 in the second position.

[0013] FIGURE 5 is a perspective view of the mop of Figure 1 having a sponge mop head attached thereto, where the sponge mop head is in a first or mopping ready position.

[0014] FIGURE 6 is a perspective view of the mop of Figure 1 having a sponge mop head attached thereto, where the sponge mop head is in a second or wrung position.

[0015] FIGURE 7a is a partial sectional view of the mop of Figure 2 with strands removed and shown in the first position.

[0016] FIGURE 7b is a partial sectional view of the mop of Figure 2 with strands removed and shown in the second position.

[0017] FIGURE 8 is a perspective view of a section of an outer housing of the mop of Figure 1 to show internal components of the mop.

[0018] FIGURE 9 is a perspective view of a power unit housing of the mop of Figure 1.

[0019] FIGURE 10 is an exploded view of the components inside the power unit housing shown in Figure 9.

[0020] FIGURE 11 is a cross section of a gear box inside the power unit housing shown in Figure 10.

[0021] FIGURE 12 is an exploded view of a transmission shown in Figure 11.

[0022] FIGURE 13a is a side view in partial cross section of the mop of Figure 2 with the strands removed.

[0023] FIGURE 13b is a close-up view of a circled portion of the mop of Figure 13a.

[0024] FIGURE 13c is a cross section of the mop of Figure 13b.

[0025] FIGURE 14a is a side view in partial cross section of the mop of Figure 2 with the strands removed.

[0026] FIGURE 14b is a close-up view of the circled portion of the mop of Figure 14a.

[0027] FIGURE 15a is a side cross sectional view of the sponge mop head of Figure 1 connected to the outer housing where the sponge mop head is in a first or mopping position.

[0028] FIGURE 15b is a side cross sectional view of the sponge mop head of Figure 1 connected to the outer housing where the sponge mop head is in a second or wrung position.

[0029] FIGURE 16 is a top plan view, in partial cross section, of a second embodiment of a sponge mop connected to the handle portion of the mop of Figure 1, where the sponge mop head is in a first or mopping position.

[0030] FIGURE 17 is a top plan view, in partial cross section of the mop of Figure 16 with the mop head shown in a second or wrung position.

[0031] FIGURE 18a is an enlarged perspective view of a switch compartment and battery compartment of the mop of Figure 1.

[0032] FIGURE 18b is an enlarged exploded perspective view of the battery compartment removed from the switch compartment of the mop of Figure 1.

[0033] FIGURE 19 is an enlarged cross sectional view of the switch compartment and battery compartment of the mop of Figure 1.

[0034] FIGURE 20 is a schematic view of the circuitry of the mop of Figure 1.

[0035] FIGURE 21 is a schematic view of a charger housing and a portion of the mop of Figure 1.

[0036] FIGURE 22 is a perspective view of the mop of Figure 2 showing manual wringing of the strand mop head.

[0037] FIGURE 23 is a perspective view of the mop of Figure 5 showing manual wringing of the sponge mop head.

#### DETAILED DESCRIPTION

[0038] Referring now to the drawings, wherein the showings are for purposes of illustrating embodiments of a mop only and not for purposes of limiting the invention to only the described embodiments, FIG. 1 shows a motorized mop 10 that includes a mop head, which can include a string mop head 12 and/or a sponge mop head 14, attached to a handle portion 16. The handle portion 16 includes a first or front tube 18 received in an outer housing 22. The first tube 18 is slidably mounted in the outer housing 22 so that it can reciprocate in the housing. A second or rear tube 24 is also received in and can slide along the length of the outer housing 22. The first tube 18 and the

second tube 24 connect with one another, as will be described in more detail below. A battery compartment 26, which houses the power source, attaches to a switch compartment 28 that is attached to an end of the second tube 24.

**[0039]** The string mop head 12 selectively attaches to the handle portion 16. The string mop head 12 includes a hollow cylindrical portion 32. A resilient tab 34 having a small protrusion 36 formed at the end of the tab is formed in the hollow cylindrical portion 32. The cylindrical portion 32 extends from an attachment ring 38 to which a plurality of mop strands 42 are secured at one end of each mop strand. The mop strands 42 are secured at an opposite end to a flared end 44 that extends from a shaft 46. A biased button 48 extends from a side wall of the shaft 46.

**[0040]** The shaft 46 selectively attaches to the front tube 18. More specifically, the shaft 46 is received in the front tube 18 and the button 48 pops out into an opening 52 near a distal end of the front tube. Accordingly, by pushing the button 48 inwardly (towards a longitudinal axis of the shaft 46) the shaft 46 can be selectively attached to or removed from the front tube 18. For the shaft 46 to be received by the first tube 18, the attachment ring 38 and the hollow cylindrical portion 32 have an opening through which both the first tube 18 and the shaft 46 can protrude. It should be appreciated, however, that the shaft 46 can attach to the front tube 18 in other known ways, including being threaded onto or into the front tube 18.

**[0041]** The hollow cylindrical portion 32 selectively attaches to the outer housing 22. An opening 54 is located adjacent an end of the outer housing 22. The protrusion 36 at the end of the resilient tab 34 on the cylindrical portion 32 fits into the opening 54 to attach the string mop head 12 to the outer housing 22. However, the cylindrical portion 32 can be attached to the outer housing 22 in other known ways, for example a threaded connection, using fasteners, and the like.

**[0042]** As mentioned above, the front tube 18 and the rear tube 24 are slidable within the outer housing 22, as shown by the arrows in FIG. 2. For use, the front tube 18 is slid into the outer housing 22 and the mop head 12 is positioned to mop the floor. With reference now to FIG. 3, the front tube 18 is extended out of the outer housing 22 when the mop head 12 is positioned to wring. As shown in FIGS. 2 and 3, when the front tube 18 extends from the

outer housing 22 the rear tube 24 retracts into the outer housing 22. Likewise, when the front tube 18 retracts into the outer housing 22, the rear tube 24 extends from the outer housing.

**[0043]** For wringing, and with reference to FIG. 4a, the strands 42 of the mop head 12 wind around the front tube 18. The front tube 18 rotates about its longitudinal axis while the attachment ring 38 and the outer housing 22 remains stationary. Therefore, the end of the strands 42 attached to the flared end 44 rotate and the end of the strands 42 attached to the attachment ring 38 do not rotate so that the strands 42 wind around the front tube 18. FIG. 4b shows the strands 42 in an unwound, or unwrung, condition.

**[0044]** With reference to FIG. 7a, the connection between the front tube 18 and the rear tube 24 is shown. The front tube 18 connects to a power unit housing 56 at an end opposite the mop head 12 or 14 (not shown in FIG. 7a). The rear tube 24 connects to the power unit housing 56 at an end opposite the switch compartment 28. As seen in FIGS. 7a and 7b, the power unit housing 56 slides within the outer housing 22.

**[0045]** With reference to FIG. 8, a pair of wings 58, which can be spaced 180 degrees apart from one another, protrude from the power unit housing 56. The wings 58 are received in channels 60 formed on the inside of the outer housing 22. Accordingly, the power unit housing 56 slides parallel to the longitudinal axis of the outer housing 22, and the wings 58 remain in the channels 60 to preclude rotation of the power unit housing 56 about the longitudinal axis. While a pair of wings is illustrated, it should be appreciated that one, three or more wings could also be employed. Moreover, other known means of preventing the rotation of the power unit housing about the longitudinal axis of the mop can also be used.

**[0046]** With reference now to FIG. 10, the power unit housing 56 can include a first section 62 that attaches to a second section 64 to enclose a plurality of internal components. The front of the power unit housing 56, the portion adjacent the front tube 18, includes a plurality of openings 66 that correspond with a plurality of openings 68 in the second section 64. Fasteners (not shown) extend through the openings 66 and 68 to attach the first section 62 to the second section 64. Other known means for attaching

the housing sections, such as adhesives, clips, rivets and the like could also be used to attach the sections.

**[0047]** Likewise, the rear of the power unit housing 56, the portion adjacent the rear tube 24, includes a pair of openings 70 in the first section 62 that align with openings 72 in the second section 64. Fasteners 74 extend through the openings 70 and 72 to engage nuts 76 to attach the rear portion of the first section 62 to the rear portion of the second section 64 of the power unit housing 56. The rear tube 24 includes a pair of openings 78 that align with the openings 70 and 72 so that fasteners 74 can protrude through the openings 78 in the rear tube 24 to affix the rear tube 24 to the power unit housing 56. Connection of the rear tube 24 to the power unit housing 56 precludes the rotation of the rear tube 24 with respect to the power unit housing. Connection of the rear tube 24 to the power unit housing 56 secures together these parts for reciprocating movement inside the outer housing. The rear tube 24 and the power unit housing 56 can also be secured together via other conventional means.

**[0048]** Disposed in the power unit housing 56, is a motor 84 that, via a transmission, which is disposed in a gear box 86 and will be described in more detail below, drives the rotational movement of the front tube 18. The motor 84 in a preferred embodiment is an electric reversible motor. If desired, the transmission can be a planetary gear transmission. It should be appreciated that other conventional drive mechanisms can also be used to power the front tube 18. An output shaft 88, which is connected to the transmission disposed in the gear box 86, attaches to the front tube 18. The output shaft 88 includes an opening 92 that aligns with a pair of aligned openings 94 (only one shown) in the front tube 18. A connecting pin 96 extends through the openings 92 and 94 to connect the front tube 18 to the output shaft 88.

**[0049]** With continued reference to FIG. 10, the first section 62 also includes a pair of aligned notches 80 that are dimensioned to receive the wings 58 of the gear box 86. Likewise, the second section 64 includes a pair of aligned notches 82 that align with the notches 80 of the first section 62. Accordingly, with the wings 58 received in the notches 80 and 82 of the power unit housing 56, the gear box 86 does not rotate with respect to the power unit



housing. Also, with the wings 58 received in the channels 60 of the outer housing 22, the gear box 86 and the power unit housing 56 do not rotate with respect to the outer housing 22 but can be slid up and down inside the outer housing 22. Even though the wings 58 have been described as attached or integral with the gear box 86, the wings 58 can also attach to the power unit housing 56 to preclude its rotation. In such an embodiment, the gear box 86 would be fixed in the power unit housing 56 so that it could not rotate with respect to the power unit housing.

**[0050]** A worm gear 98 attaches to or is received on the output shaft 88. The worm gear 98 engages a limit gear 102 that rotates about an axis perpendicular to the worm gear. The limit gear 102 is attached to and coaxial with a cam 104. As the output shaft 88 rotates, the worm gear 98 also rotates driving the limit gear 102 to rotate the cam 104. The cam 104 engages a limit switch 106, which is electrically connected to the motor 84 and a power source, which will be described in more detail below. The cam 104 and the gears 98 and 102 are designed such that after a predetermined number rotations of the output shaft 88 and thus the motor 84, the cam 104 engages the switch 106 to stop the delivery of power to the motor 84. Even though a mechanical limit switch has been described, other conventional limit switches, or controllers including electronic limit switches, reed sensors and the like, can also be used to control the delivery of power to the motor 84.

**[0051]** With reference to FIG. 11, the motor 84 drives the output shaft 88 through a planetary transmission 112. Even though a planetary transmission 112 is disclosed, other conventional transmissions, including other gear reduction mechanisms, can be used with the motor 84. With reference to FIG. 12, the motor 84 drives a drive shaft 114 having a pinion 116 mounted thereto. The pinion 84 drives a plurality of first planetary gears 118 mounted to a first carrier plate 122. A first carrier pinion 124 attaches to a side of the first carrier plate 122 opposite the side to which the first planetary gears 118 mount. In this embodiment, the first carrier pinion 124 mounts to the carrier plate 122 axially aligned with the drive shaft 114 and the output shaft 88.

**[0052]** The first carrier plate pinion 124 can engage a plurality of second planetary gears 126 mounted to a second carrier plate 128. A second carrier pinion 132 attaches to a side of the second carrier plate 128 opposite the side

to which the second planetary gears 126 mount. The second carrier pinion 132 also axially aligns with the drive shaft 114 and the output shaft 88.

**[0053]** The second carrier pinion 132 can engage a third plurality of planetary gears 134 which are mounted to a third carrier plate 136. It is apparent that the output shaft 88 protrudes from the third carrier plate 136. The motor 84 drives the drive shaft 114 rotating the pinion 116. The pinion 116 engages the planetary gears 118 which engage an inside surface 138 of the gear box 86. Since the gear box 86 does not rotate because the wings 56 are retained by the power unit housing 56 and the channels 60 of the outer housing 22, the first carrier plate 122 rotates about an axis defined by the drive shaft 114 and the output shaft 88. The rotation of the first carrier plate 122 results in the rotation of the first carrier pinion 124 which drives the second set of planetary gears 126. The second set of planetary gears 126 also engage the inside surface 138 of the gear box 56 resulting in rotation of the second carrier plate 128. Rotation of the second carrier plate 128 results in rotation of the second carrier pinion 132 which engages the third plurality of planetary gears 134. The third plurality of planetary gears 134 engages the inside surface 138 of the gear box 86 resulting in the rotation of the third carrier plate 136 which results in the rotation of the output shaft 88.

**[0054]** As mentioned above, the front tube 18 rotates to wring the string mop head 12. With reference to FIG. 13b, the cam 104 contacts the limit switch 106 in an off position so that power is no longer delivered to the motor 84 to stop the rotation of the front tube 18. With reference to FIG. 14b, when the cam 104 no longer contacts the switch 106, the switch is in the on position and power is being delivered to the motor 84.

**[0055]** With continued reference to FIG. 14, a second limit switch 142 can prevent operation of the motor 84 when the front tube 18 is retracted into the outer housing 22. The switch 142, which is optional, is located on power unit housing 56 near the connection to the rear tube 24 and is aligned with one of the tracks 60 in the outer housing 22. When the switch 142 is located outside of the track 60, an arm 144 of the switch 142 is depressed and the switch prevents power from being delivered to the motor. The switch 142 is located outside of the track when the front tube 18 is retracted into the outer housing 22 and the rear tube 24 is extended from the outer housing, i.e., the mopping

position. When the switch 142 is located in the track 60, the arm 144 is extended and the switch allows power to be delivered to the motor 84. The switch is located in the track 60 when the front tube 18 is extended from the outer housing 22 and the rear tube 24 is retracted in the outer housing, i.e., the wringing position. Even though a limit switch 142 has been described, other controllers can be used to regulate power to the motor, including sensors, e.g. optical sensors, magnetic sensors and the like.

**[0056]** With reference to FIG. 18a, the battery compartment 26 selectively attaches to the switch compartment 28. While one means of providing power to the motor 84 is the battery compartment 26, it should be appreciated that the motor could also be powered from a wall outlet via a conventional electric cord and a transformer (not illustrated). The benefit of employing battery power for this purpose is to enable the user to move the mop as need without being tied to an electrical outlet. Referring to FIG. 18b, the switch compartment 28 includes a male threaded end 146 that is received in a female threaded end 148 of the battery compartment 26. With reference to FIG. 19, the battery compartment holds a plurality of batteries 152, which in this embodiment can be C batteries. Alternatively, the one or more batteries in the battery compartment can be rechargeable cells. A pair of contacts 154 are located in the female end 148 of the battery compartment 26 that contact a pair of contacts 156 located on the male end 146 of the switch compartment 28 when the battery compartment 26 attaches to the switch compartment 28.

**[0057]** With reference again to FIG. 18a, the user of the mop 10 depresses a button 162 to actuate the wringing of the mop head 12. The button 162 controls a main switch 164, which is electrically connected to the batteries 152 and the motor 84. With reference to FIG. 20, the main switch 164 includes internal switches A and B. When the button 162 (FIG. 18) is depressed, switch A opens and switch B closes so that the motor turns in a first, wringing, direction. When the button 162 is released, switch B opens and switch A closes so that the motor turns in a second, unwinding, direction, which is opposite the first direction. As mentioned, the limit switch 106 controls the delivery of power to the motor 84 when button 162 is released.

**[0058]** While the switch 106 controls the power to the motor 84, the position of the cam 104 controls the operation of the switch. In this manner,

the switch 106 can be referred to as self-positioning because power will be delivered to the motor 84 until the cam 104 returns to a predetermined position whereby the switch 106 is returned to the off position and power is no longer delivered to the motor 84.

**[0059]** As also seen in FIG. 20, the second limit switch 142 can also control the delivery of power to the motor 84. The second limit switch can be referred to as a safety switch since it precludes the delivery of power to the motor 84 when the front tube 18 is retracted in the outer housing 22.

**[0060]** The circuitry for the mop 10 can also include an overload switch 166. The overload switch 166 can be a bi-metal switch that cuts out or shorts when the current being delivered to the motor 84 is too high over a predetermined time. The overload switch can prevent motor burnout and save batteries. A current at which the overload switch 166 cuts out can be dependent upon the type of electric motor 84 and power source. The overload switch 166 cuts out power when the motor 84 stalls, such as when the string mop head 12 is fully twisted and continues to try to twist.

**[0061]** In addition to, or in lieu of, using conventional batteries to power the mop 10, the mop can include a rechargeable power source. With reference to FIG. 21, the rear tube 24 can include a mounting opening 172 and a plug inlet 174. The rear tube 24 is received in a recess 176 formed in a charger/hanger housing 178. A mounting hook 182 and an electric plug 184 are positioned in the recess 176. The mounting hook 182 is received in the mounting opening 172 to retain the rear tube 24. The plug 184 is received in the plug inlet 174 to deliver power to the rechargeable power source.

**[0062]** The charger/hanger housing 178 electrically connects to a conventional wall outlet (not shown). The housing 178 can include a plug inlet 186 that is electrically connected to the plug 184. The plug inlet 186 receives a plug 188 which is electrically connected to a wall transformer 192 that plugs into the conventional wall outlet. The wall transformer 192 is generally known in the art and can include a class 2 power supply. The housing 178 can include a fastener 194 so that the housing 178 can mount to a wall so that the entire unit can be hung and recharged at the same time.

**[0063]** In the event of a power failure, or when desirable, a user of the mop 10 can also manually wring the mop head 12. To wring manually, the

attachment ring 38 is rotated when the front tube 18 is extended from the outer housing 22. To rotate the attachment ring 38, the attachment ring 38 is removed from the outer housing 22 by removing the protrusion 36 from the opening 54 in the outer housing 22. The attachment ring 38 can then be rotated.

**[0064]** With reference back to FIG. 1, the sponge mop head 14 can also selectively attach to the handle portion 16. The sponge mop head 14 includes a hollow cylindrical portion 202 received in the outer housing 22. A resilient tab 204 having a protrusion 206 is formed in the hollow cylindrical portion 202, similar to the string mop head 12. The protrusion 206 extends into the opening 54 in the outer housing 22 to attach the sponge mop head 14 to the outer housing. As seen in FIGS. 5 and 6, the sponge mop head 14 can also be automatically wrung.

**[0065]** With reference to FIGS. 15a and 15b, the cylindrical portion 202 of the sponge mop head 14 projects from a head frame 208 having a U-shaped end 212. A pair of rollers 214 attach at each end of the U-shaped end 212. A sponge 216 is retractable into an interior space defined by the U-shaped end. In one means of attachment, the sponge 216 attaches to a lead screw 218, which is aligned with the longitudinal axis of the front tube 18 when the head 14 is attached to the outer housing 22, through a clamp 222 and bar 224. The sponge 216 is selectively removable from the clamp 222 by loosening wing nuts 230 located on the bar 224.

**[0066]** A lead screw nut 226 is threadably received on the lead screw 218. Included is an attachment member 228 to attach the lead screw nut 226 to the front tube 18. The lead screw nut 226 is retained by an internal wall 232 of the head frame 208. Accordingly, as the front tube 18 is rotated by the motor 84, the front tube turns the lead screw nut 226. Since the lead screw nut 226 can not move axially along the lead screw 218 because of the internal wall 232, the lead screw 218 is drawn axially into the front tube 18 as the lead screw nut 226 is tightened. The limit switches 106, 142 and 166 discussed above can control the movement of the lead screw 218.

**[0067]** An opening 234 is also provided in the head frame 208 to provide access to the attachment member 228. The opening 234 allows the user of the mop 10 to reach in and disconnect the front tube 18 from the lead screw

nut 226 so that the sponge mop head 14 can be removed from the handle portion 16.

**[0068]** With reference to FIG. 16, a flat sponge 242 can also be selectively attached to the handle portion 16. The flat sponge 242 attaches to a first plate 244 and a second plate 246. The first plate 244 pivotally mounts to a hinge 252 and the second plate 246 also pivotally mounts to the hinge 252. In this embodiment, the hinge attaches to the lead screw 218, described above. The lead screw 218 cooperates with the lead screw nut 226 and the front tube 18 in a similar manner to the mop head 14 described above. In the embodiment depicted in FIGS. 16 and 17, the space defined by the U-shaped portion of the frame can be larger to accommodate the flat sponge 242 and the plates 244 and 246.

**[0069]** With reference to FIG. 23, the user of the mop 10 with the sponge mop head 14 can also manually wring the sponge mop head when so desired. To manually wring the sponge mop head 14, the front tube 18 is retracted into the outer housing 22 and the rear tube 24 is pulled from the outer housing. With reference back to FIGS. 15a and 15b, this action pulls the lead screw nut 226 away from the internal wall 232, which pulls the lead screw 218 toward the rear of the handle portion. This pulls the sponge 216 back into the space defined by the U-shaped end 212 so that the sponge is forced between the rollers 214.

**[0070]** The mop has been described with reference to preferred embodiments. Modifications and alterations will occur to those upon reading the preceding description. All such modifications that come within the appended claims, or the equivalents thereof, are intended to be covered.

## CLAIMS:

1. A mop (10) comprising:
  - an elongated handle portion (16);
  - a movable member (22) slidably mounted on the handle portion;
  - a rotary motor (84) disposed in at least one of the elongated handle portion and the movable member;
  - a controller (106) in electrical communication with the motor and an associated power source, wherein the controller regulates power to the motor as a function of a number of rotations of the motor; and
  - a mop head (12, 14) including an absorbent material, the mop head being detachably connected to at least one of the elongated handle portion and the movable member, and being selectively connected to the motor.
2. The mop of claim 1, wherein the absorbent material comprises a sponge (216).
3. The mop of claim 1, wherein the absorbent material comprises a plurality of fiber strands (42).
4. The mop of claim 1, wherein the mop head includes a first latch element (32, 34, 36, 202, 204, 206) and the movable member includes a second latch element (52, 54), the first and second latch elements cooperating to selectively secure the mop head to the movable member.
5. The mop of claim 1, further comprising a battery compartment (26) for storing batteries (152) to power the motor.
6. The mop of claim 5, further comprising an on-off switch (164) in electrical communication with the battery compartment and the motor.
7. The mop of claim 1, wherein the control further comprises a mechanical limit switch (102, 104) for controlling the number of rotations of the motor in at least a first rotational direction.

8. The mop of claim 1, further comprising a switch (166) in electrical communication with the motor and the associated power source, wherein the switch controls the amount of current flowing to the motor.

9. The mop of claim 1, further comprising a switch (142) in electrical communication with the motor and the associated power source, wherein the switch controls power to the motor as a function of the location of the movable member in relation to the handle portion.

10. The mop of claim 1, wherein at least one of the movable member and the handle portion is configured to limit rotational movement of at least a portion of the handle portion with respect to the movable member.

11. The mop of claim 1, wherein the mop head is movable between a use position and a wringing position by sliding movement of the movable member (22).

12. A self-wringing mop (10) comprising:  
an elongated handle (16);  
a movable member (22) slidably connected to the handle;  
an electric reversible motor (84) disposed in at least one of the handle and the movable member;

a mop head (12, 14) attached to the elongated handle and the movable member, and operably connected to the motor, wherein the mop head is movable between a use position and a wringing position by sliding movement of the movable member; and

a switch element (164) in electrical communication with the motor and an associated power source (152), wherein the switch element comprises a first switch (A) for delivering current to the motor in a first direction and a second switch (B) for delivering current to the motor in a second, opposite, direction.

13. The self-wringing mop of claim 12, further comprising a button



(162) for activating the switch element, wherein upon pressing the button the first switch is closed and the second switch is open, and upon releasing the button the second switch is closed and the first switch is open.

14. The self-wringing mop of claim 12, further comprising a limit switch (106) in electrical communication with the motor and the power source, wherein the limit switch is opened and closed in response to movement of the mop head.

15. The self-wringing mop of claim 12, further comprising an overload switch (166) in electrical communication with the motor and the power source, wherein the overload switch opens at a predetermined current.

16. The self-wringing mop of claim 12, wherein the mop head comprises a sponge mop (14) and when the first switch (A) is closed current is delivered to the motor in the first direction so that the sponge mop moves from a use position to a wrung position and when the second switch (B) is closed current is delivered to the motor in the second direction so that the sponge mop moves from the wrung position to the use position.

17. The self-wringing mop of claim 12, wherein the mop head comprises a plurality of fiber strands (42) and when the first switch (A) is closed current is delivered to the motor in the first direction so that the fiber strands are wound in a first rotational direction and when the second switch (B) is closed current is delivered to the motor in the second direction so that the fiber strands are unwound in a second rotational direction.

18. A self-wringing mop (10) comprising:  
a handle (16);  
a slidable member (22) slidably connected to the handle;  
a rotating member (88) connected to the handle;  
a mop head (12, 14) connected to the slidable member and the rotating member, the mop head comprising an absorbent material (42, 216);

a motor (84) operably connected to the rotating member, wherein the motor drives the rotating member which moves the absorbent material between a wrung and an unwrung position;

a power source compartment (26) disposed in at least one of the handle and the slidable member for receiving an associated power source (152); and

a limit switch (106) in electrical communication with the motor and the power source compartment, the limit switch opens in response to the position of the absorbent material.

19. The self-wringing mop of claim 18, wherein the mop head is movable between a use position and a wringing position by sliding movement of the slidable member.

20. The self-wringing mop of claim 19, further comprising a button (162), and a switch element (164) in selective contact with the button, wherein the switch element comprises a first switch (A) for delivering current to the motor in a first direction and a second switch (B) for delivering current to the motor in a second, opposite, direction.



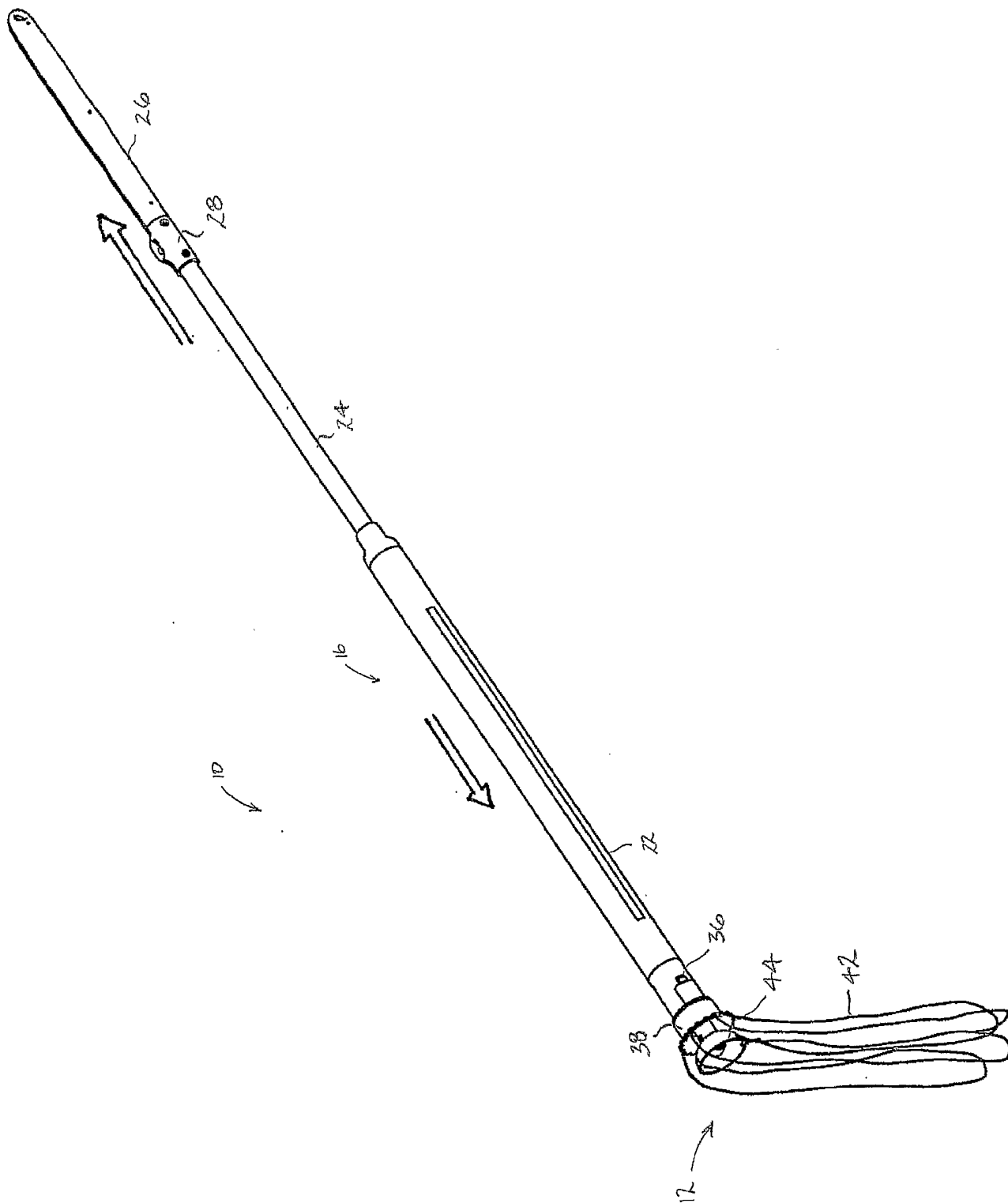

FIG 2

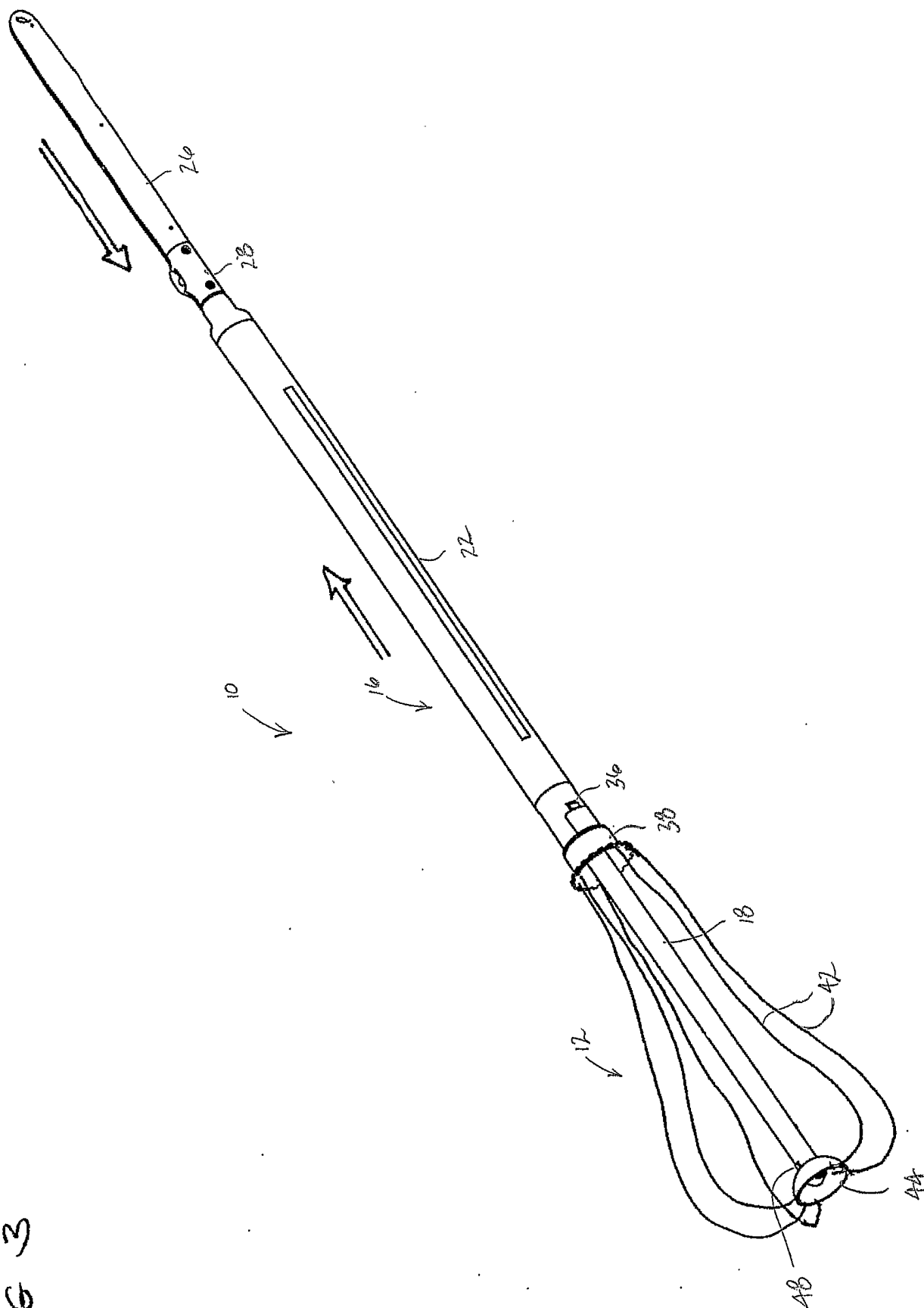
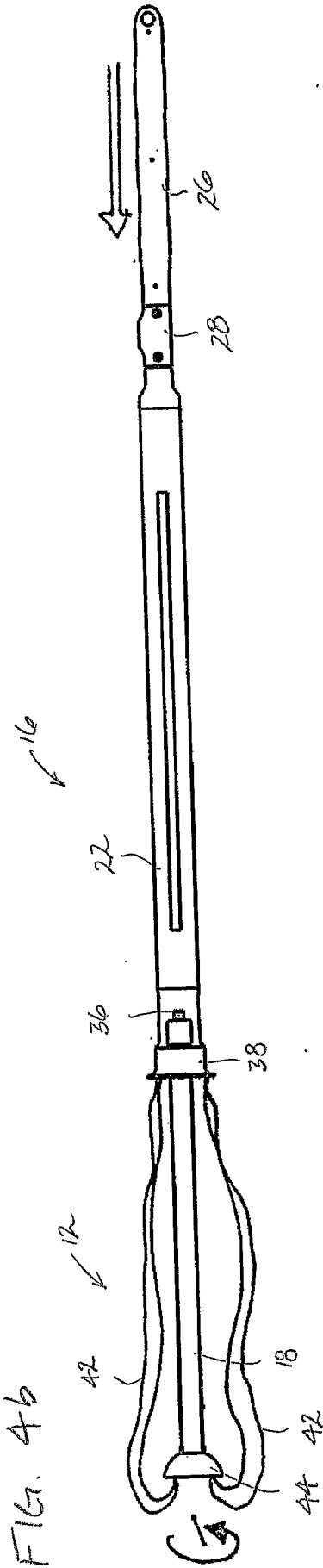
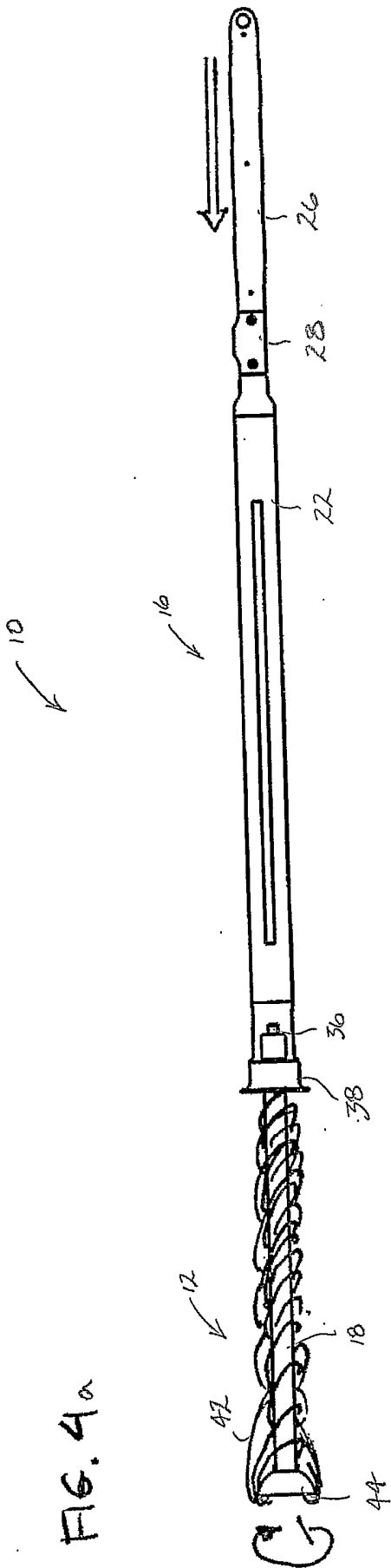

FIG 3



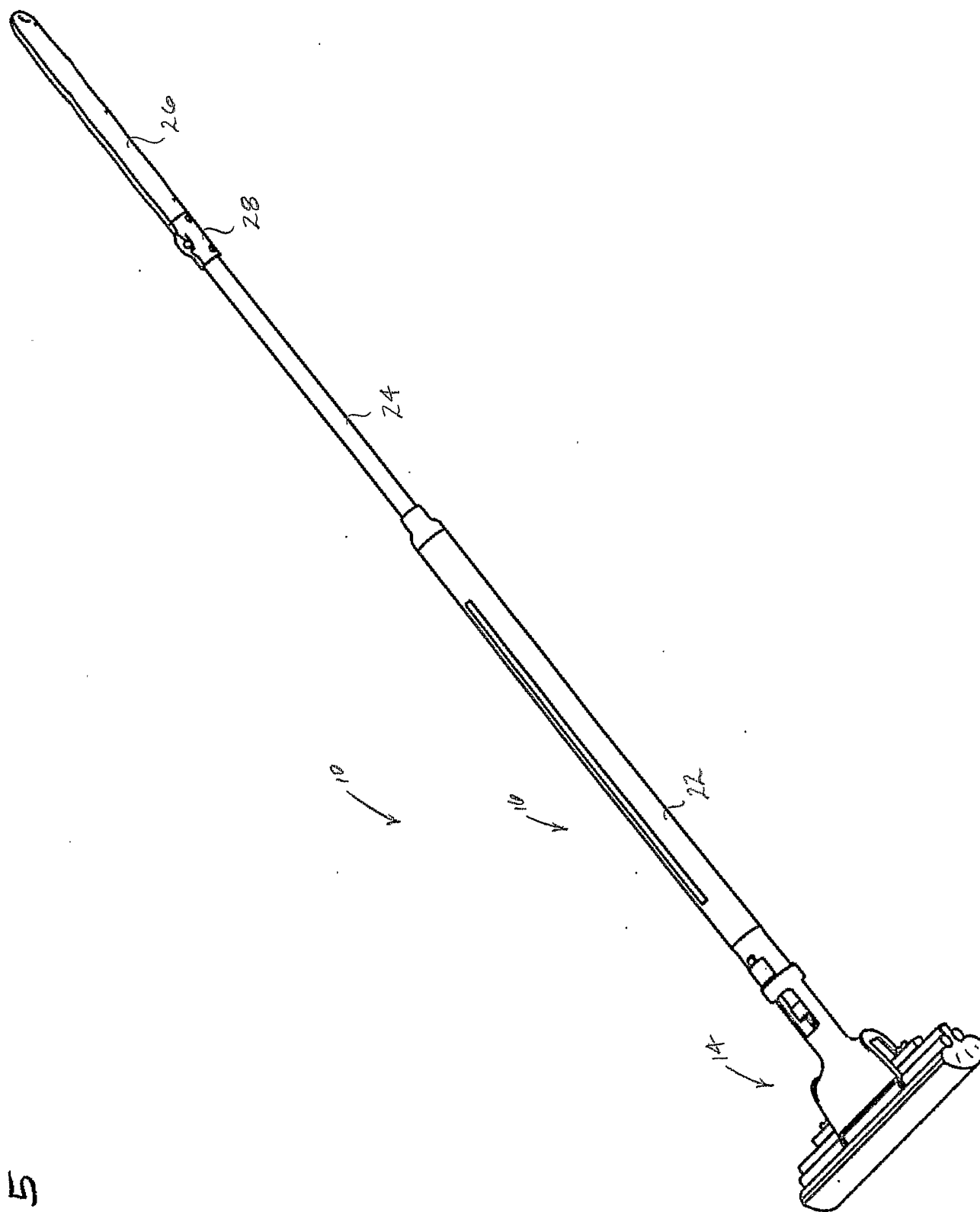

FIG. 5

FIG. 6

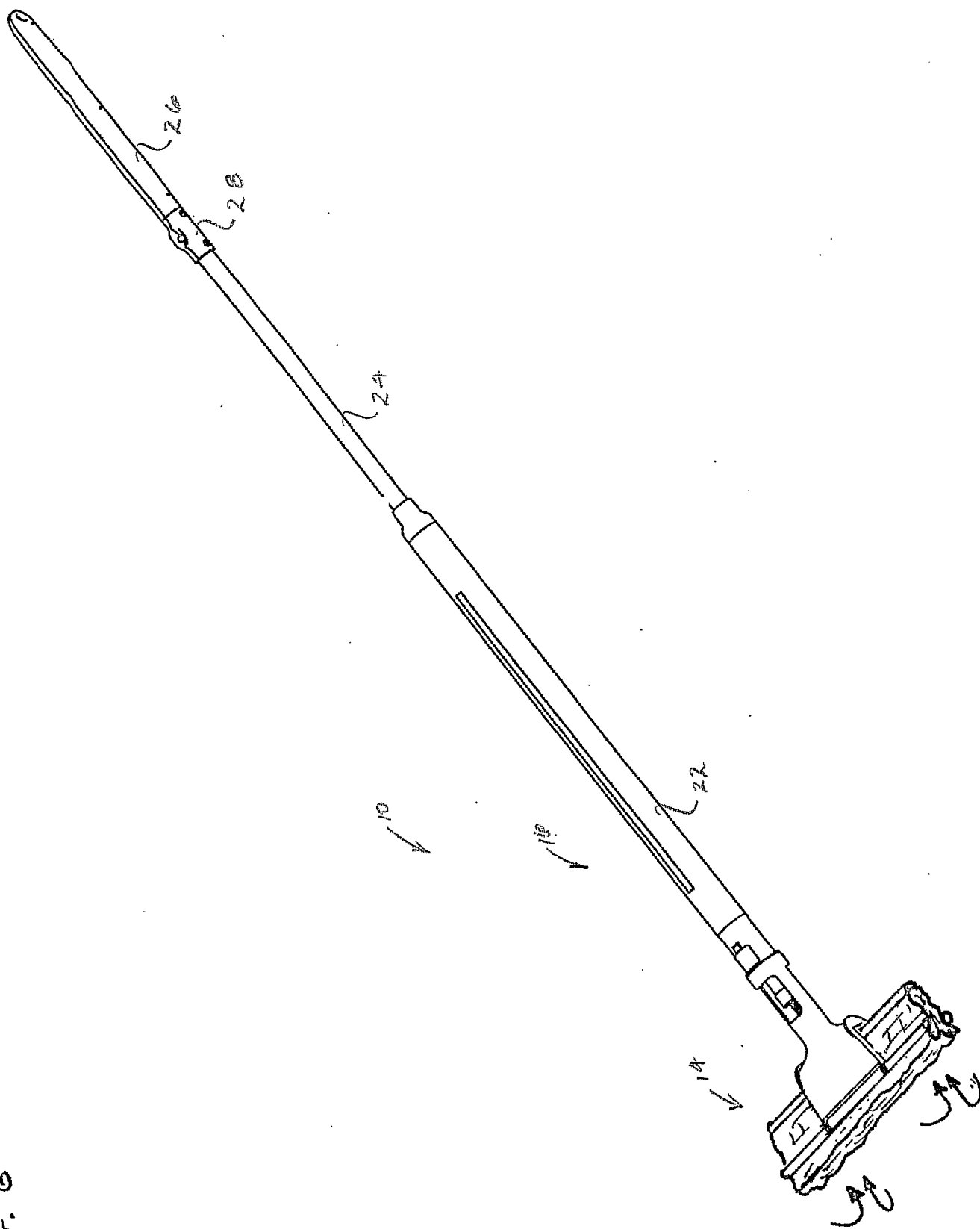



FIG. 7a

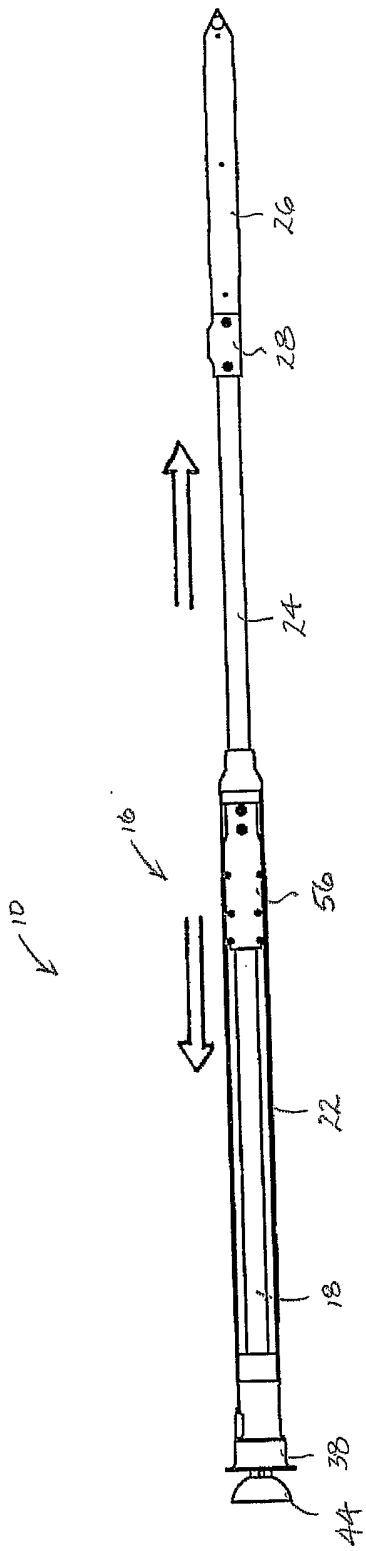
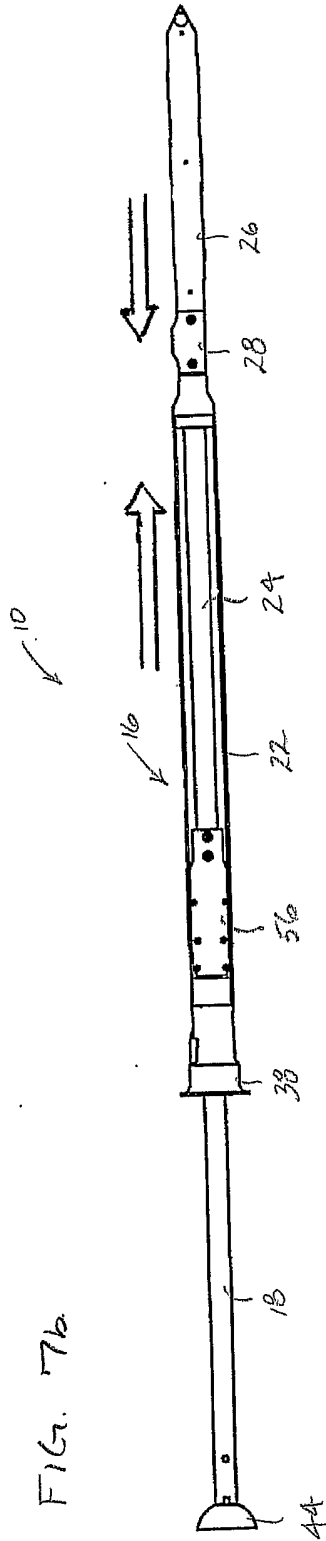

FIG. 7b



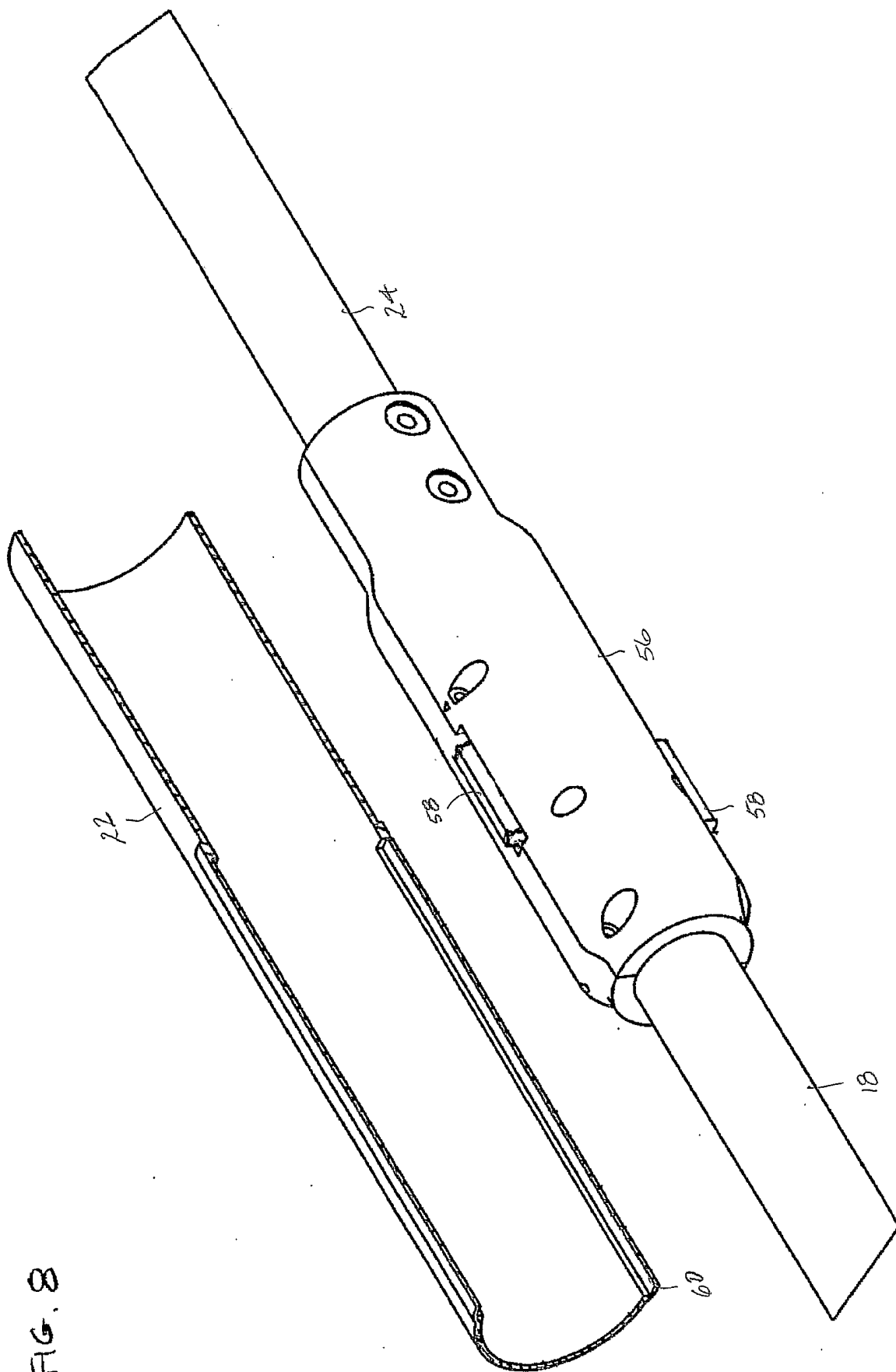

FIG. 8

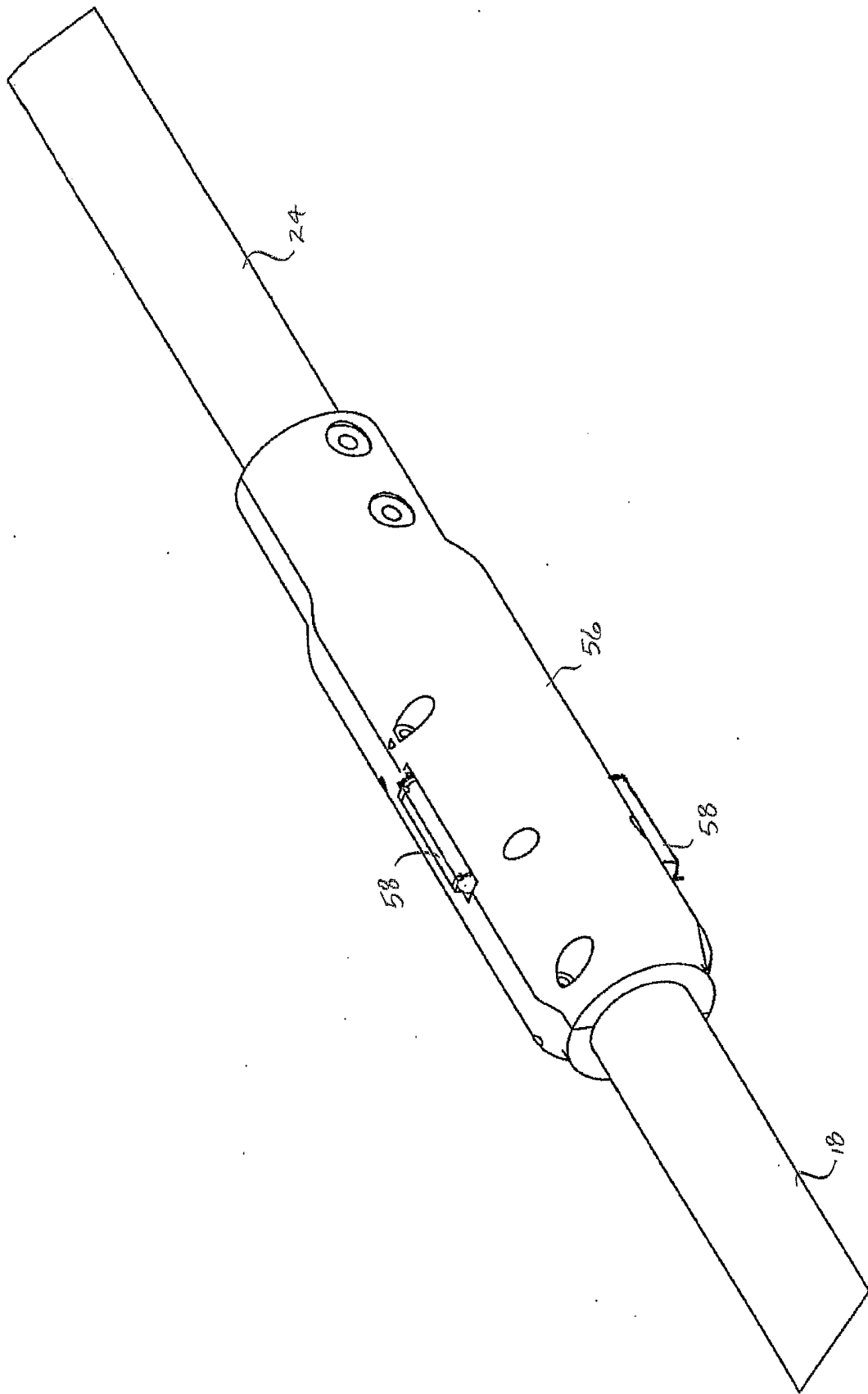

FIG. 9

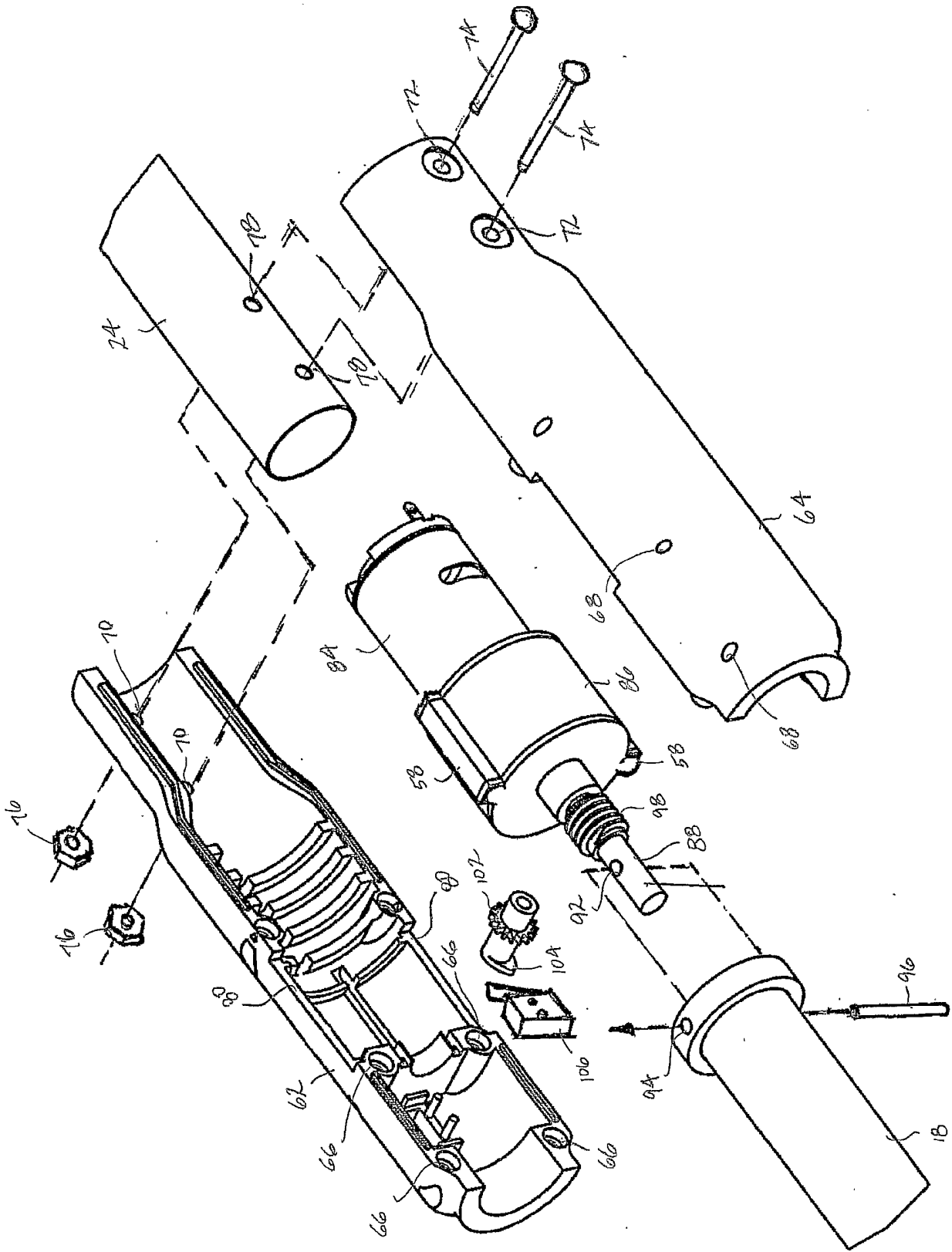

FIG. 10

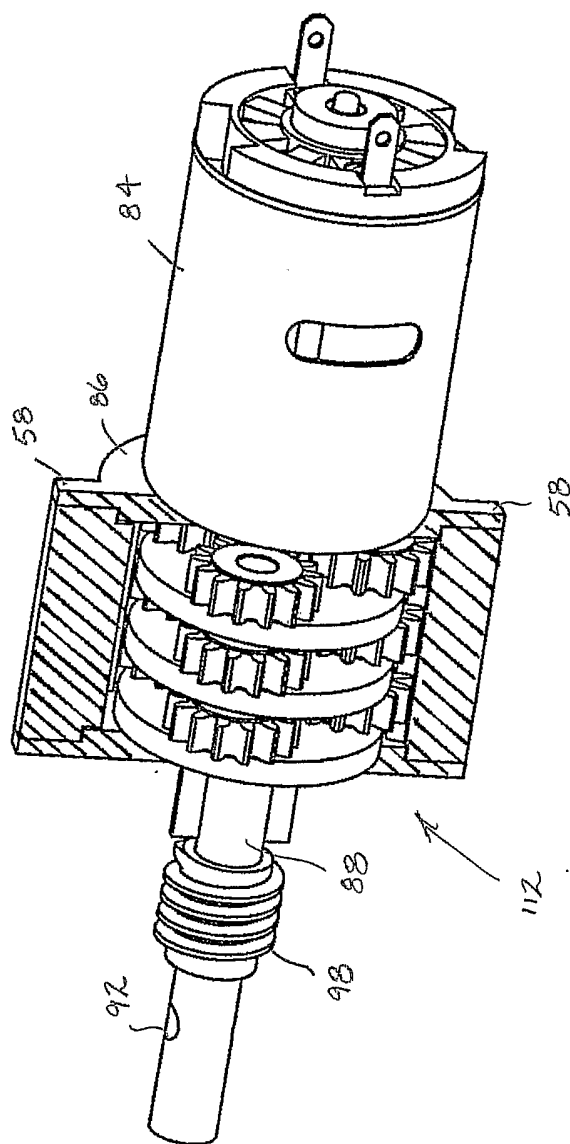

FIG. 11

FIG. 12

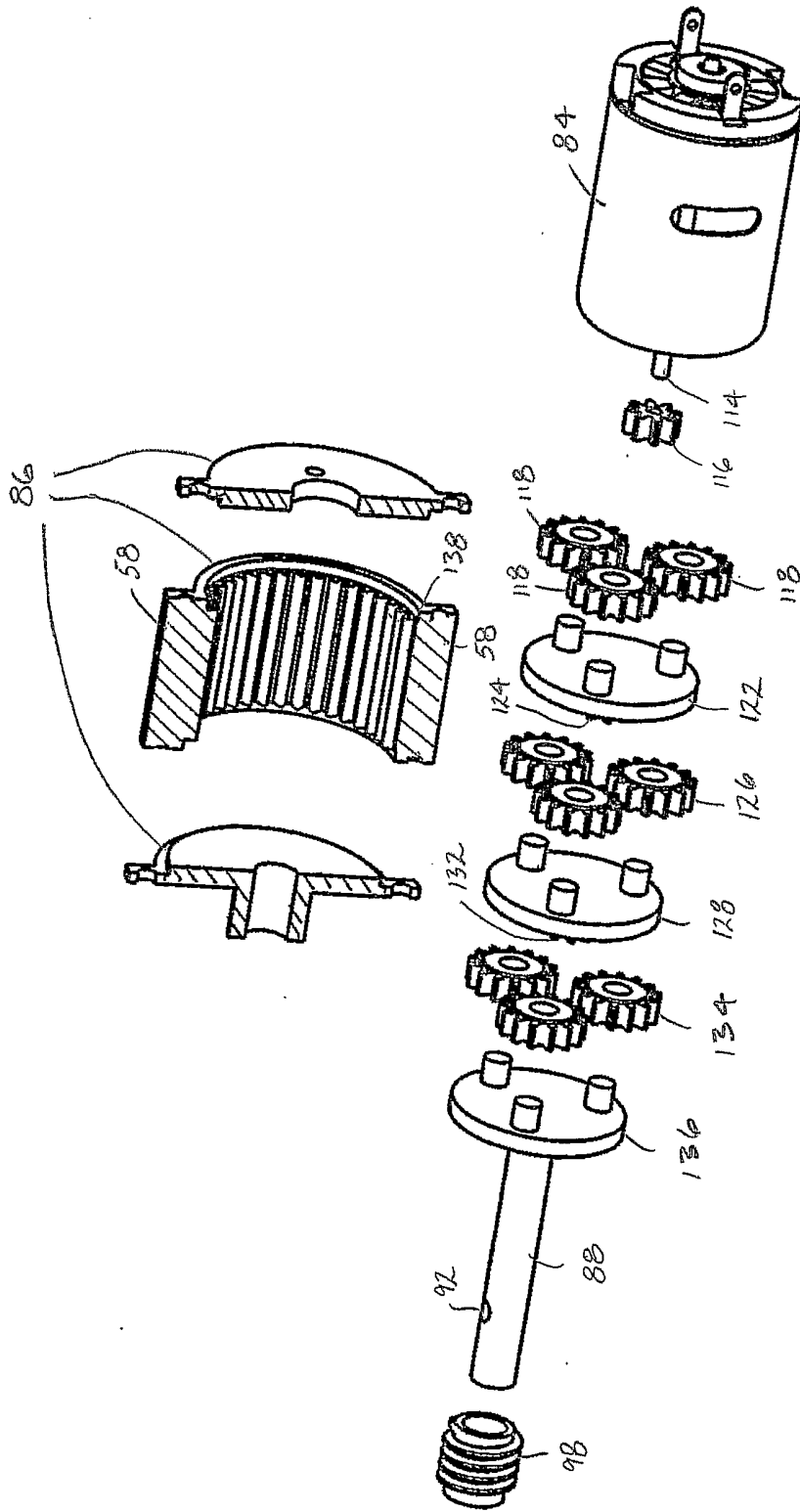

FIG. 13a

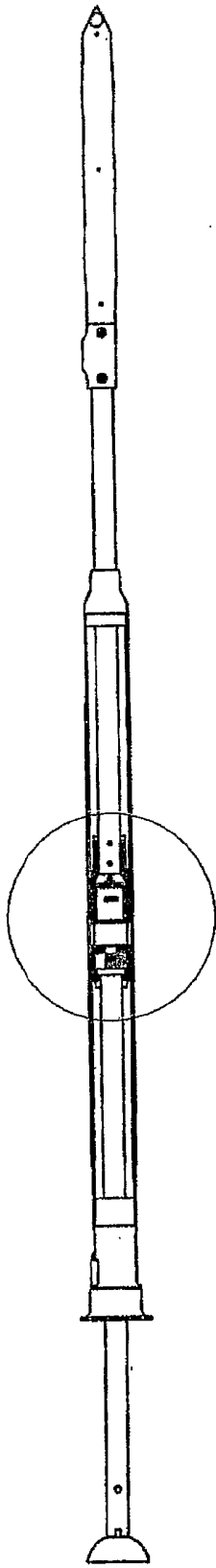

FIG. 13c

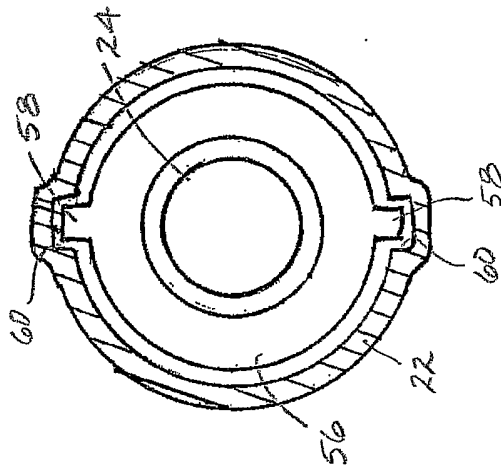

FIG. 13b

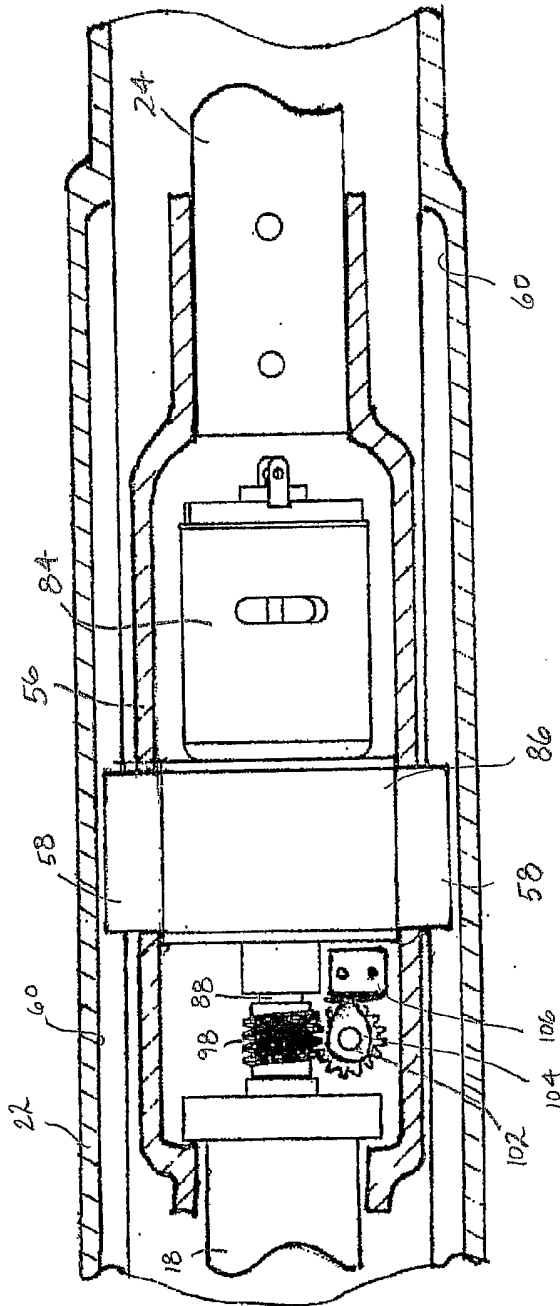

FIG. 14a

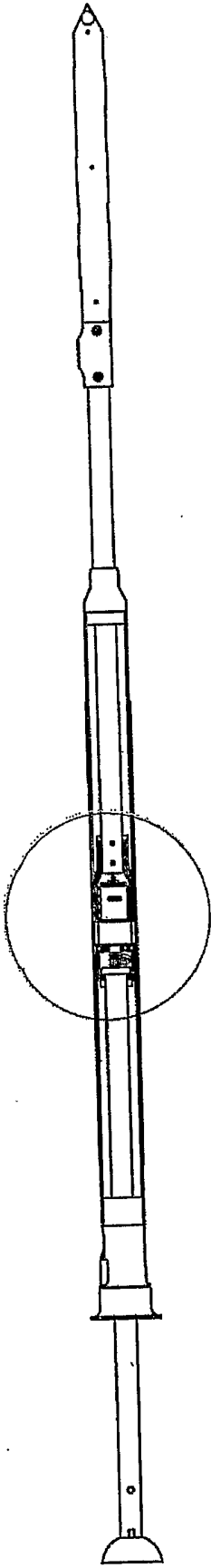

FIG. 14b

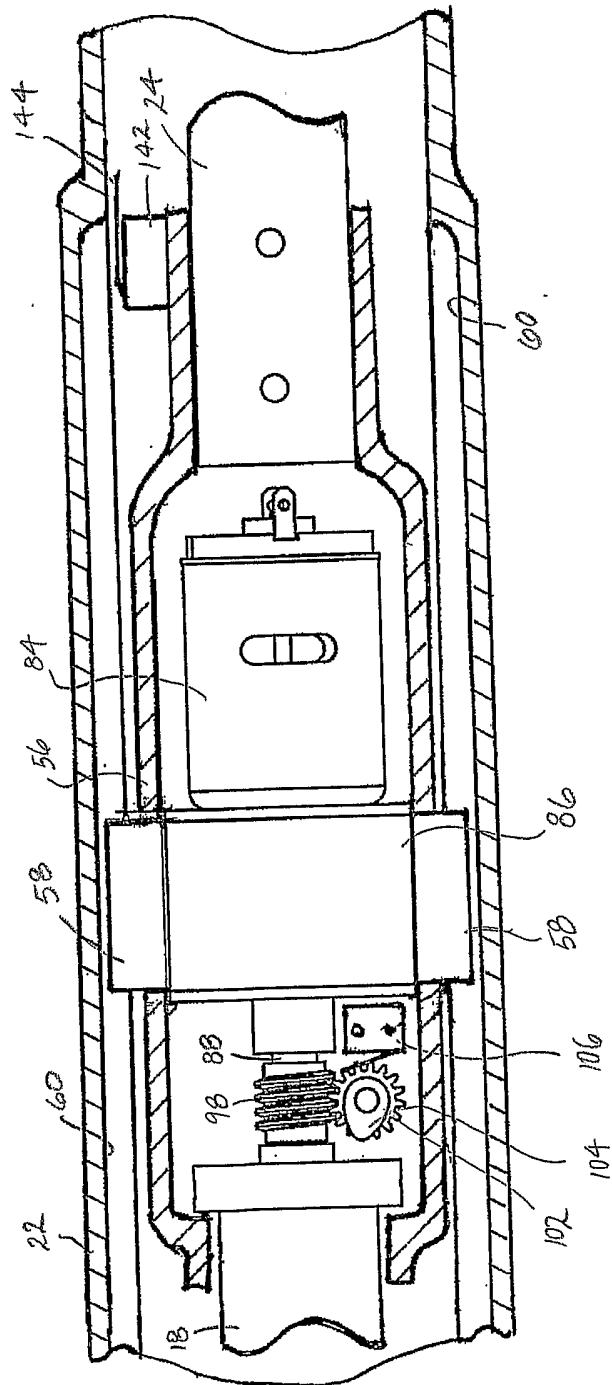



FIG. 15a.

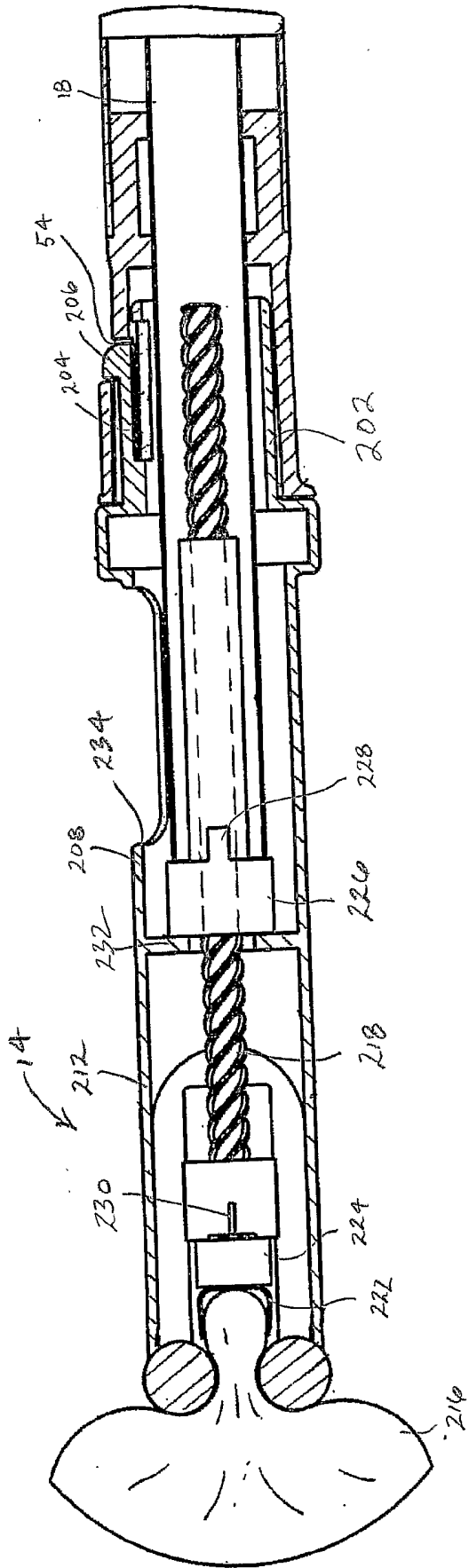

FIG. 15b

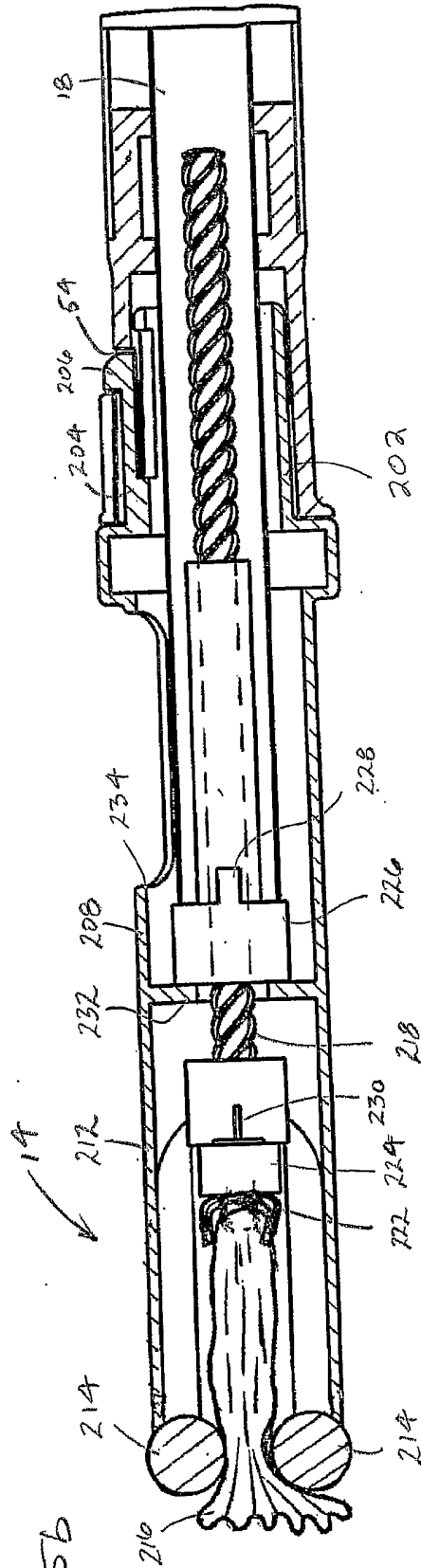

FIG. 16

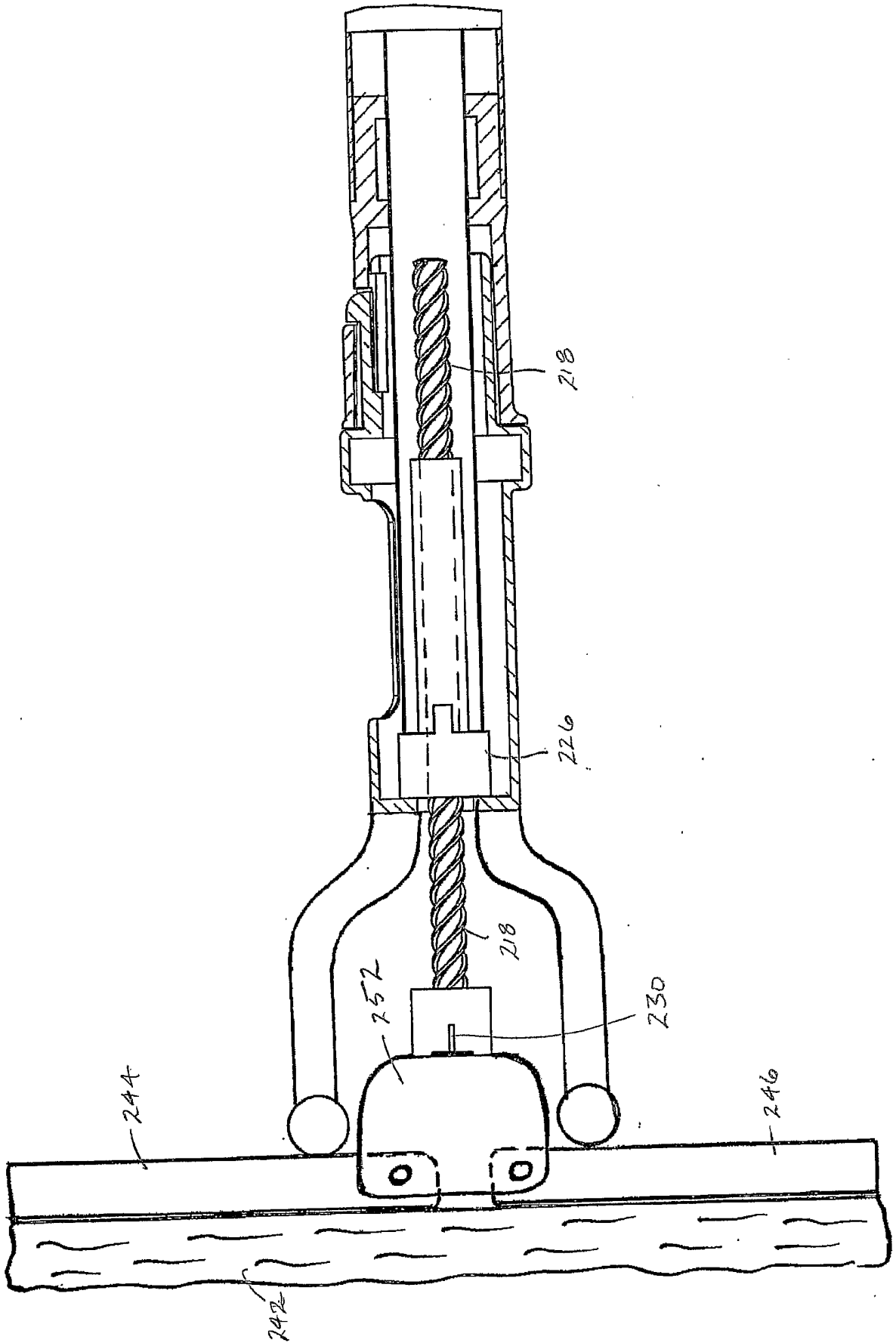
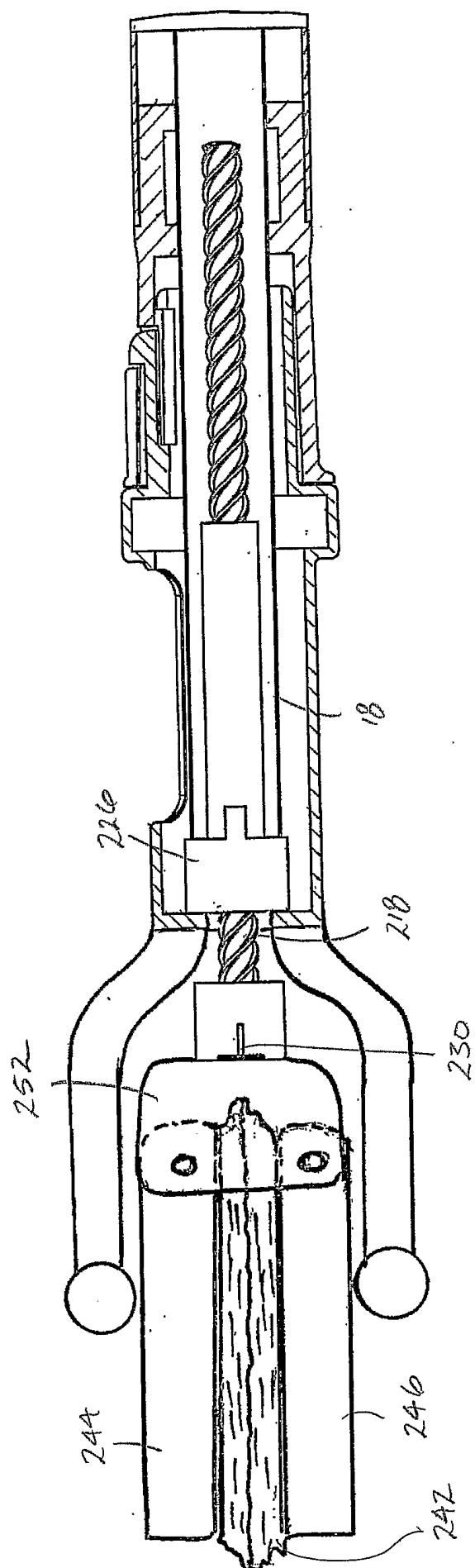

FIG. 17



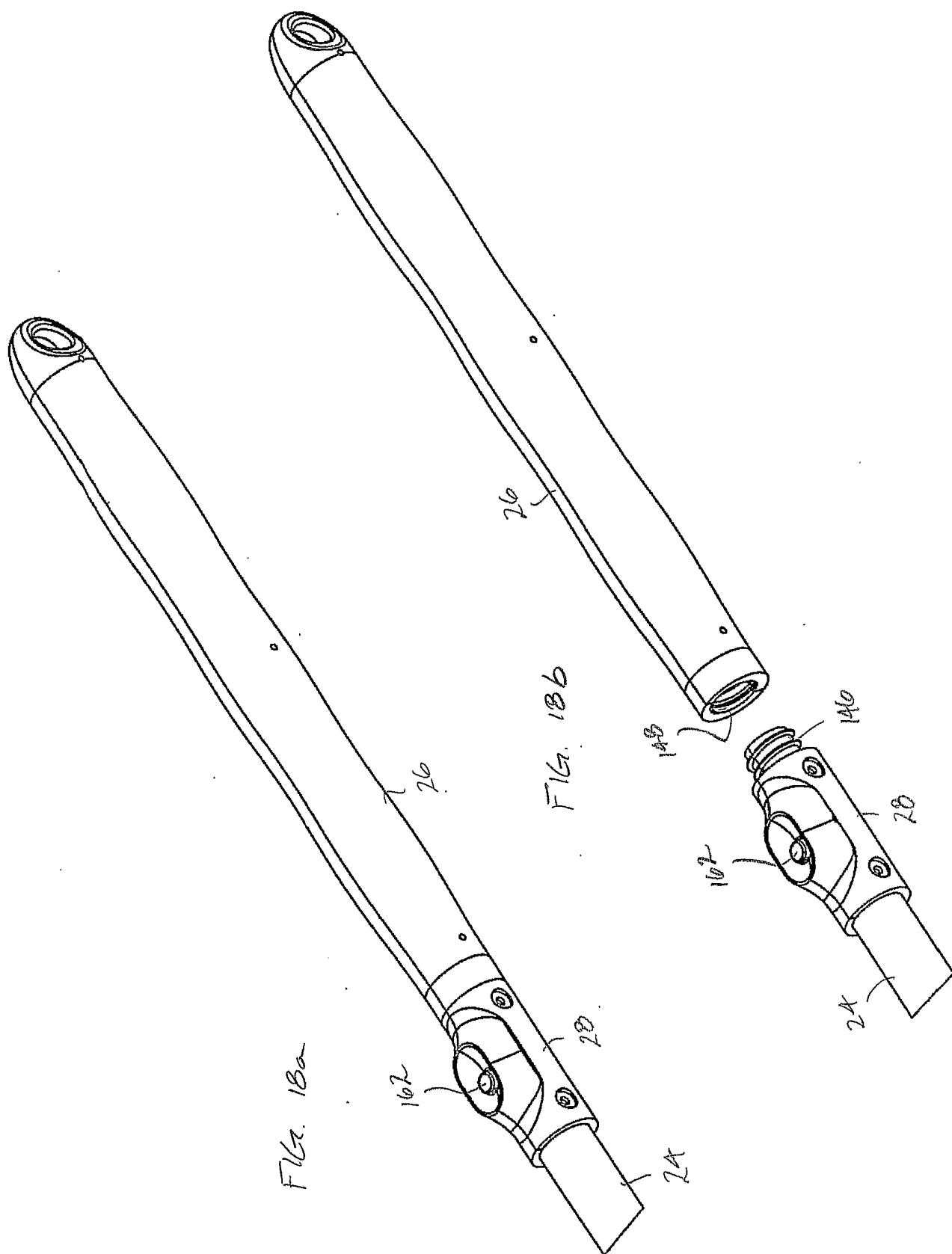

FIG. 19

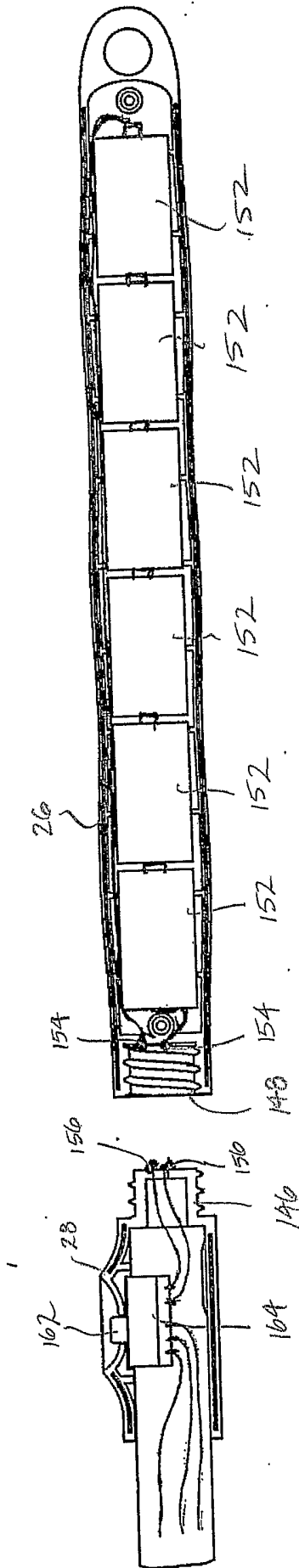

FIG. 20

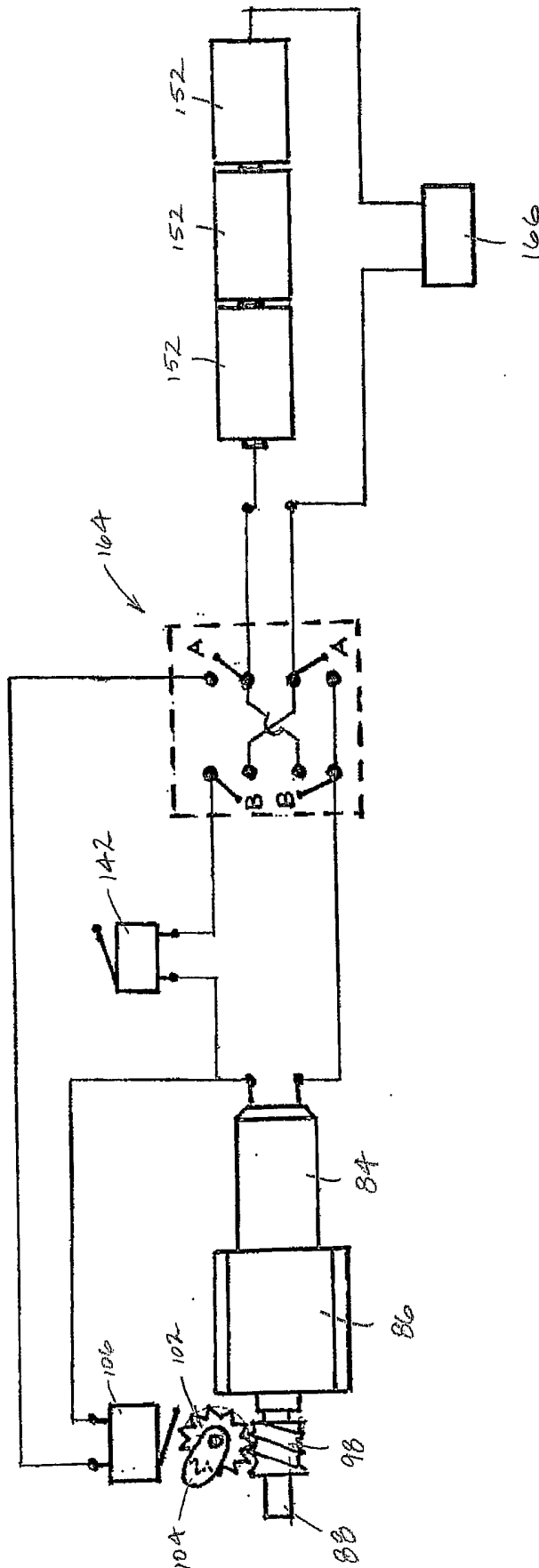

FIG 21

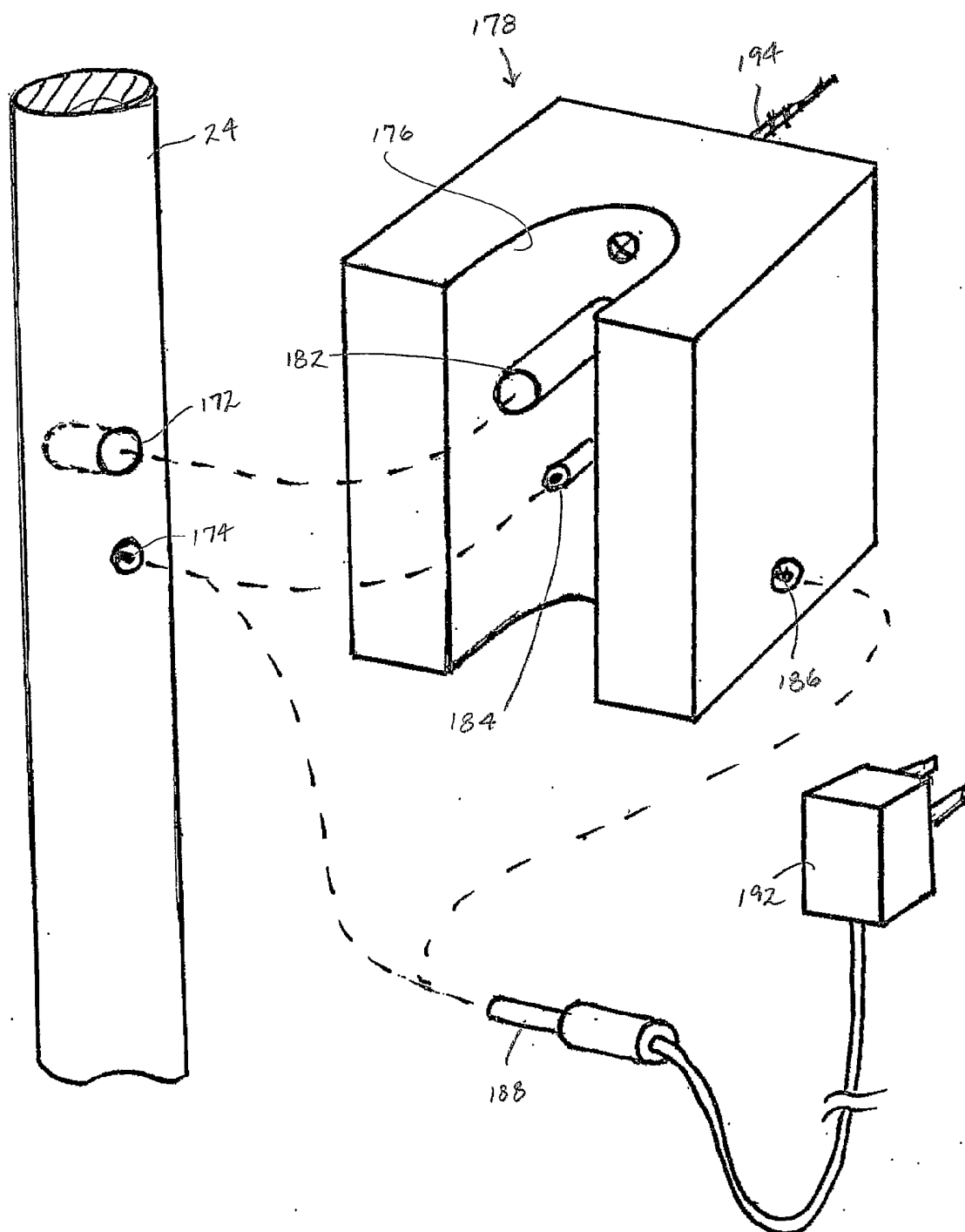

FIG. 22

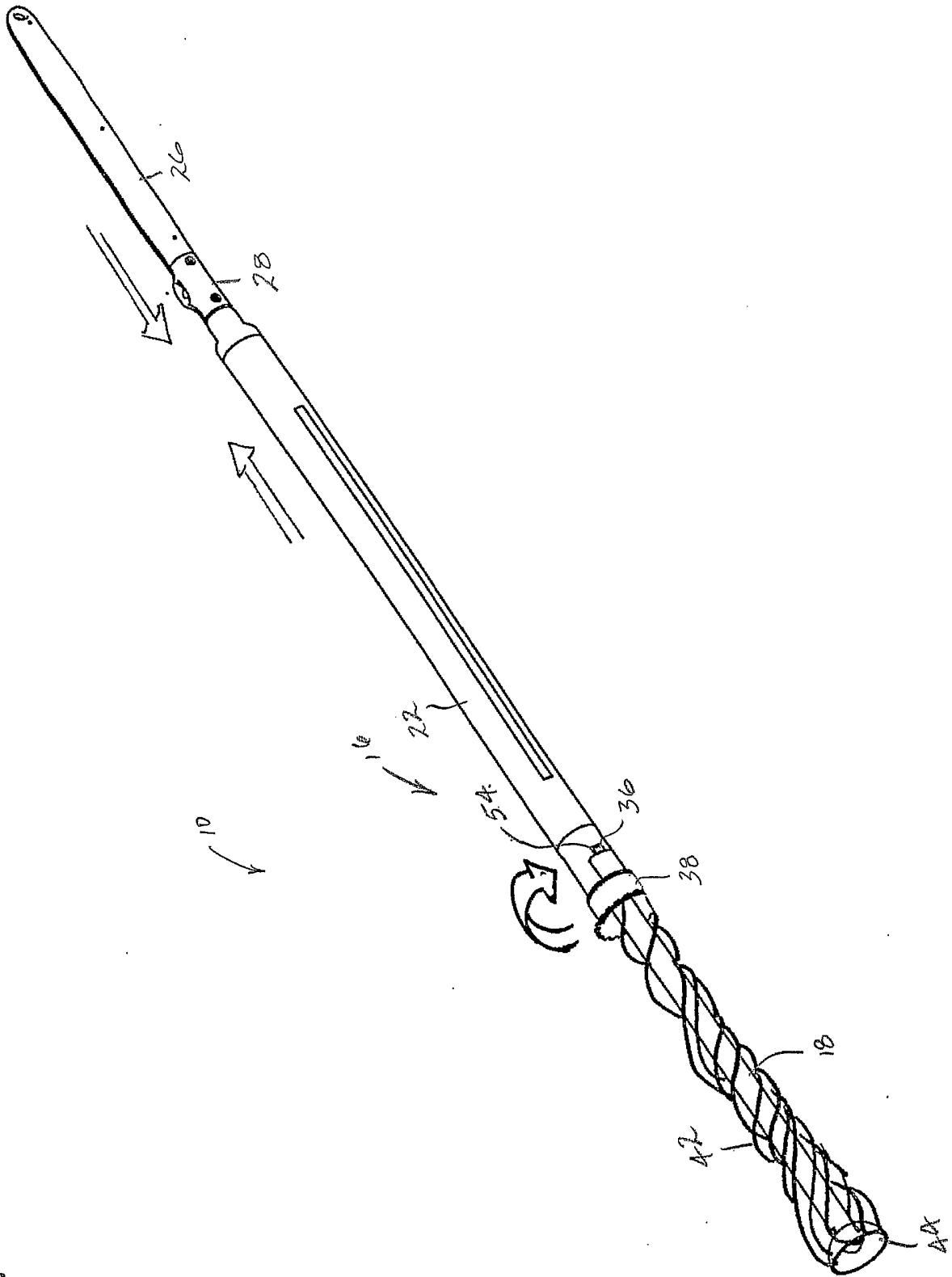
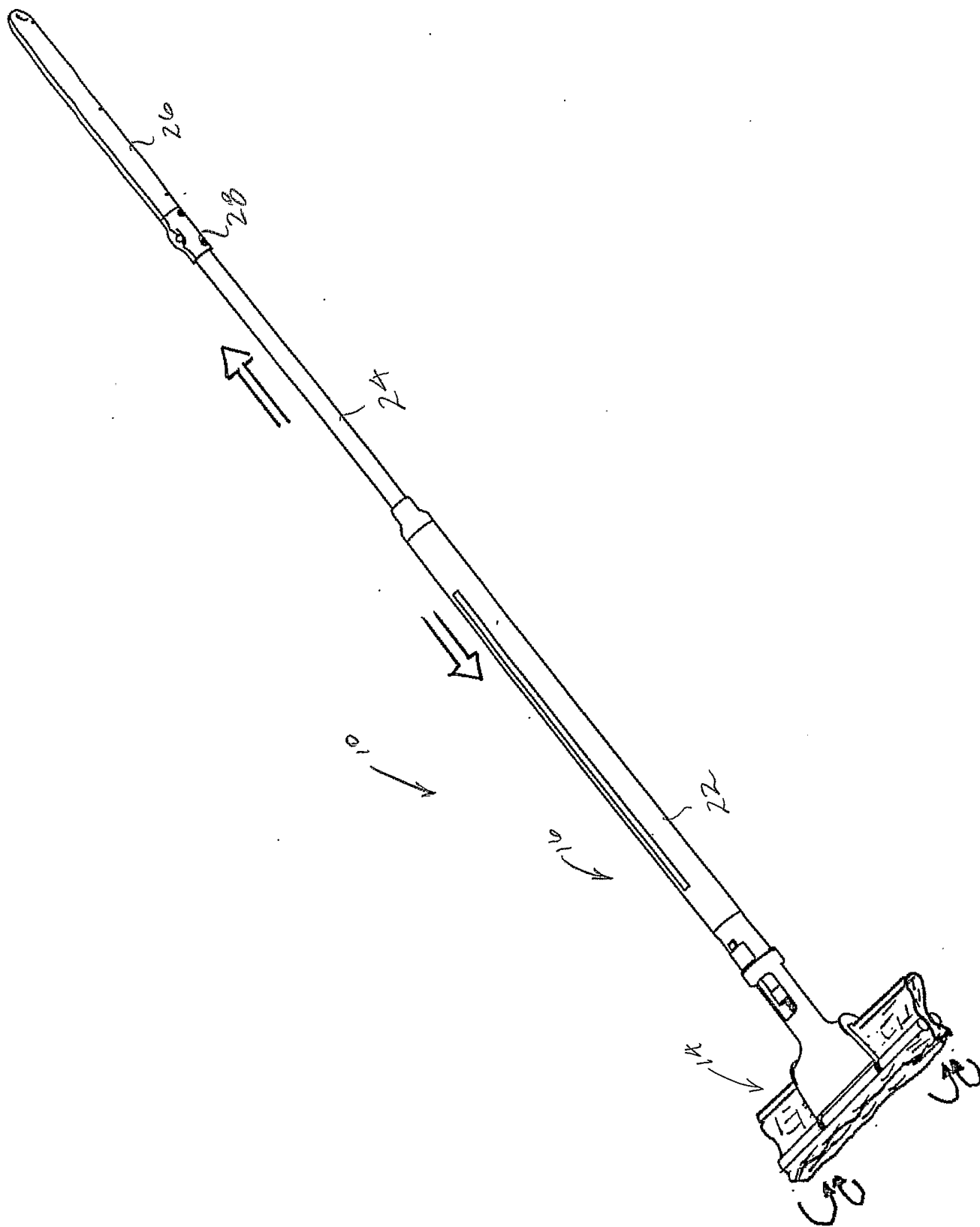



FIG. 23



# INTERNATIONAL SEARCH REPORT

International Application No  
**PCT/US2005/009320**

**A. CLASSIFICATION OF SUBJECT MATTER**  
 IPC 7 A47L13/142 A47L13/146

According to International Patent Classification (IPC) or to both national classification and IPC

**B. FIELDS SEARCHED**

Minimum documentation searched (classification system followed by classification symbols)  
 IPC 7 A47L

Documentation searched other than minimum documentation to the extent that such documents are included in the fields searched

Electronic data base consulted during the international search (name of data base and, where practical, search terms used)  
 EPO-Internal, WPI Data, PAJ

**C. DOCUMENTS CONSIDERED TO BE RELEVANT**

Category °	Citation of document, with indication, where appropriate, of the relevant passages	Relevant to claim No.
X	US 2002/104179 A1 (MAYNE HARLO S ET AL) 8 August 2002 (2002-08-08) page 1, paragraph 1 page 1, paragraph 3 - paragraph 7 page 2, paragraph 35 - page 3, paragraph 100 figures 1-23	1-20
X	GB 2 249 947 A (P * MCKAY; PETER * MCKAY) 27 May 1992 (1992-05-27) page 1, line 1 - line 19 page 3, line 12 - line 26 figures 1-3	1,3,12, 18-20
	----- -/-	

Further documents are listed in the continuation of box C.       Patent family members are listed in annex.

° Special categories of cited documents :

"A" document defining the general state of the art which is not considered to be of particular relevance "E" earlier document but published on or after the international filing date "L" document which may throw doubts on priority claim(s) or which is cited to establish the publication date of another citation or other special reason (as specified) "O" document referring to an oral disclosure, use, exhibition or other means "P" document published prior to the international filing date but later than the priority date claimed	"T" later document published after the international filing date or priority date and not in conflict with the application but cited to understand the principle or theory underlying the invention "X" document of particular relevance; the claimed invention cannot be considered novel or cannot be considered to involve an inventive step when the document is taken alone "Y" document of particular relevance; the claimed invention cannot be considered to involve an inventive step when the document is combined with one or more other such documents, such combination being obvious to a person skilled in the art. "&" document member of the same patent family
---	---

Date of the actual completion of the international search <b>8 June 2005</b>	Date of mailing of the international search report <b>20/06/2005</b>
---	---

Name and mailing address of the ISA European Patent Office, P.B. 5818 Patentlaan 2 NL - 2280 HV Rijswijk Tel. (+31-70) 340-2040, Tx. 31 651 epo nl, Fax: (+31-70) 340-3016	Authorized officer  <b>Redelsperger, C</b>
--	--

# INTERNATIONAL SEARCH REPORT

International Application No  
PCT/US2005/009320

C.(Continuation) DOCUMENTS CONSIDERED TO BE RELEVANT		
Category °	Citation of document, with indication, where appropriate, of the relevant passages	Relevant to claim No.
X	US 4 875 246 A (MACGREGOR ET AL) 24 October 1989 (1989-10-24)	18-20
A	column 1, line 5 - line 11 column 1, line 44 - column 2, line 10 figures 1-15	1,12
A	----- US 5 964 003 A (ROGERS ET AL) 12 October 1999 (1999-10-12) column 1, line 4 - line 6 column 1, line 20 - line 28 figures 1,4 -----	1,12,18

# INTERNATIONAL SEARCH REPORT

Information on patent family members

International Application No  
PCT/US2005/009320

Patent document cited in search report	Publication date	Patent family member(s)	Publication date
US 2002104179 A1	08-08-2002	NONE	
GB 2249947 A	27-05-1992	NONE	
US 4875246 A	24-10-1989	US 4959628 A	25-09-1990
US 5964003 A	12-10-1999	NONE	