



W. PORTER.  
Shingle Machine.

No. 111,379.

Patented Jan'y 31, 1871.

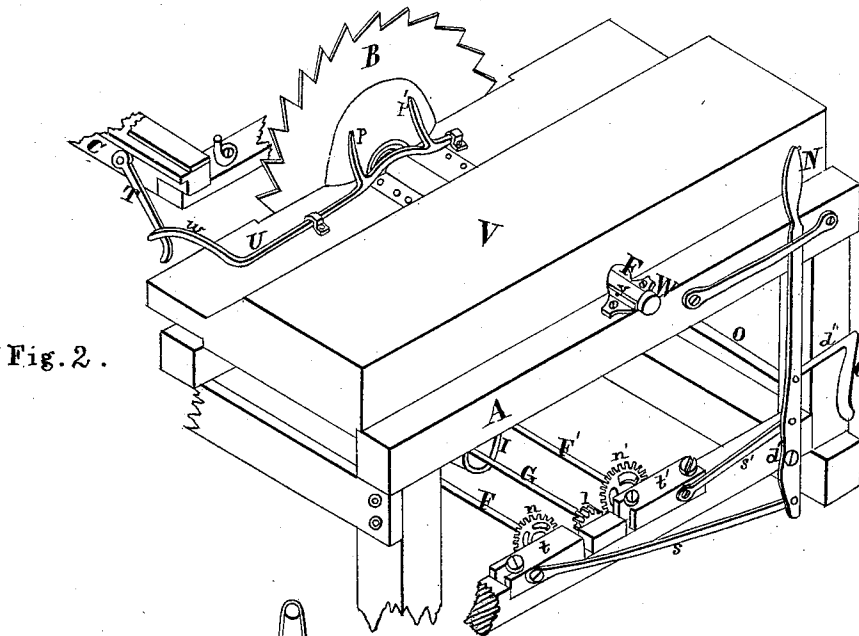

Fig. 2.

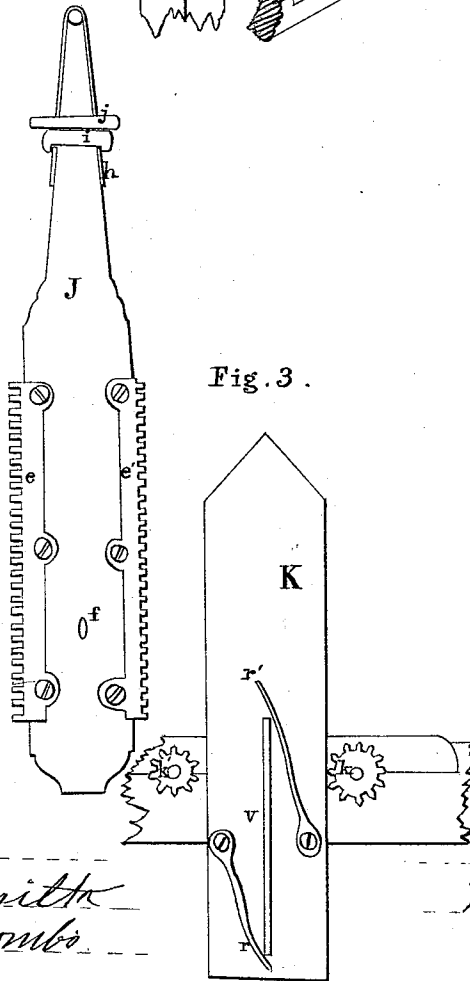

Fig. 3.



Fig. 4.

Witnesses  
*Hon. S. Smith*  
*Fred. H. Combs*

Inventor  
*Willis Porter*

# United States Patent Office.

WILLIS PORTER, OF ORONO, MAINE.

Letters Patent No. 111,379, dated January 31, 1871.

## IMPROVEMENT IN SHINGLE-MACHINES.

The Schedule referred to in these Letters Patent and making part of the same.

To all whom it may concern:

Be it known that I, WILLIS PORTER, of Orono, in the county of Penobscot and State of Maine, have invented certain new and useful Improvements in Shingle-Machines; and I do hereby declare that the following is a full and exact description thereof, reference being had to the accompanying drawing and to the letters of reference marked thereon.

The nature of my invention consists of an improved method of moving the shingle-bolt carriage and of adjusting the feed-gear.

In the accompanying drawing—

Figure 1, sheet No. 1, is a perspective view of the whole machine, with the cover V removed.

Figure 2, sheet No. 2, is a perspective view of the operating side of the machine, showing the cover V and shingle-tipper U in place.

Figure 3, sheet No. 2, is a view of the pendent arm J, showing its connection with K and the guide *v*, springs *r r'*, gear-wheels *k k'*, racks *e e'*, strap *h*, gib *i*, key *j*, and spur *f*.

Figure 4, sheet No. 2, is a sectional view of the ratchet S, showing the ratchet-wheel *a*, spring pawl, and its connection with the rod L.

To enable others skilled in the art to make and use my invention, I will now proceed to describe its construction and operation.

I provide a suitable frame or bench A A A, and arrange upright corner-posts Q Q, to which I attach vertical slides Z Z to keep the bolt-carriage C C in proper position while ascending and descending by the saw.

I provide the usual set works, which are operated by the set-shaft P. The shaft P is actuated by the set-rod L, in connection with the ratchet S and the screw-collars *b* and *c*, together with the stop *d*. The rod L is connected with and hangs from the ratchet S on the carriage, and rises and falls, therefore, with the carriage, the stop *d* being fixed or stationary.

I provide a pendent arm, J, with a rack on each edge, as at *e e'*, fig. 3, and with a projecting spur, *f*, and attach it to a rod, *g*, fig. 1, in the under side of the bolt-carriage, by a strap, gib, and key *h i j*.

I provide two shafts, F F, with gear-wheels *n n'* and *k k'*, fig. 3, at their respective ends—*n n'* operating in connection with the intermediate gear-wheel L, and *k k'*, fig. 3, operating in connection with the racks *e e'*, fig. 3.

I provide for throwing the cog-wheels *n n'* and *k k'* into or out of gear by means of the lever N and combined or attached lever O, figs. 1 and 2, in connection with the rods *s s'*, fig. 2, and the movable boxes *t t'*.

I provide a shingle-flipper, U, fig. 2, with arms or prongs *p p'* and the arm or lever *w*, which is operated by the long hook T, attached to the bolt-carriage C.

I provide a set ring, R, fitting on the shaft E, and set in place on the shaft by means of the set-screw *x*.

In operation the power is applied to the pulley D and shaft E. The set collar R is fastened firmly in place on the shaft and bears against the box *y*, thus preventing the saw from vibrating. The belt H transmits motion to the shaft G and gear-wheel 1, and the wheels *n n'* are then brought into gear with the wheel 1 by the movement of the lever N at the back of the machine; or the same object is attained by the use of the long lever O, which extends along the end and to the front of the machine. The revolution of 1 causes *n n'* to revolve in opposite directions, and *k k'*, being on the same shafts, respectively revolve in corresponding directions with *n n'*.

The spur *f* in the arm J runs on the right-hand side of the guide *v*, fig. 3, as shown in the drawing, and forces the rack *e* to engage with the gear-wheel *k*, and this carries the bolt-carriage up by the face of the saw. As the carriage rises the rod L slides in the stop *d* until the collar *c* comes in contact with *d* and causes the rod to draw upon the ratchet S and revolve the set-shaft P, which regulates the set works by the usual cams, as can be seen at *u*, so that when the carriage comes to the top of the saw the bolt is set over for another shingle. At this moment the spur *f* arrives at the top of the guide *v*, fig. 3, and is instantly thrown to the opposite side of *v* by the spring *r'*. This causes the rack *e* to engage with the wheel *k'*, and the carriage is driven downward. As the carriage ascends the hook T engages the arm or lever *w* of the shingle-tipper U and lifts it up, thus tipping the prongs *p p'* over away from the saw and onto the table; in this way the shingle sawed in the previous descent of the carriage is tipped out of the way of the succeeding shingle. As the carriage descends the weight of the lever *w* causes the prongs to tip back against the saw, and they are thus brought between the saw and each shingle as it is sawed.

The coil-spring M is attached to the frame A, and the cord X passes around the box of the spring and is fastened to the carriage so that, as it descends and the cord is drawn out, the spring is coiled up and exerts a lifting force upon the carriage, while the spur *f*, fig. 3, is passing the lower end of the guide *v* and the arm J is being transmitted from the action of the wheel *k'* to engage with *k*. It is here that the spring is peculiarly serviceable in giving the carriage a quick start upward and preventing any hesitation in the movement of J while being transferred from its engagement with *k'* to its engagement with *k*. When the carriage descends the collar *b*, on the set rod L, comes in contact with the stop *d* and arrests the further descent of the rod L. This pushes the ratchet S upward and backward until the spring-pawl con-

tained in S engages with the ratchet-wheel *a*, fig. 4, and is thus prepared to revolve the set shaft P as the carriage again ascends.

The shaft P is provided with a double cam, *u*, at each end, and as the shaft revolves one end of the cam engages the hook *a''''* of the latch B and depresses it, thereby withdrawing the spur *a''''* from the rack P'', while the other end of the cam engages the rack P'' and throws it forward. At this instant the cam leaves the latch *a''''*, and the spur *a''''* enters the rack P'' in the space next to the one from which it was withdrawn. The cams are so arranged on the shaft P that they act alternately at each end at the half revolution of the shaft.

As it is necessary that these operations should be performed exactly, and the latches frequently need regulating, I construct a latch-holder, A, with slots, which enable it to be moved in several directions enough to regulate the latch and cause the spur *a''''* to enter the rack at exactly the right instant, thereby insuring a uniform thickness to the shingle so far as any movement of the set works affects them. By reference to the drawing it will be seen that if the screw *a'*, fig. 1, be loosened in the slot *b'*, then the latch-holder A can be moved up or down on this side, throwing the latch a trifle forward or backward, and the reverse may be accomplished with *a'' b''*, while by loosening both screws the latch-holder may be moved up or down, as desired.

In order to provide against the vibration of the saw in either direction, I fix a permanent ring or collar, W, on the end of the shaft; or, if deemed necessary, this may be a set collar, so that when the shaft is crowded forward the collar W bears against the outside of the box *y*, and the set collar R is then adjusted to bear against the inside end of the box and set firmly in place by means of the set-screw *x*, thus providing a bearing or shoulder against each end of the box. Quite a slight vibration of the saw causes a difference in the thickness of the shingles, thereby lessening their market value.

The arrangement of the lever N in connection with the rod and lever O enables the operator to throw the gear-wheels *n n'* into or out of gear with 1 while standing at the opposite side of the machine; for by pressing on the end of O, fig. 1, at *d''*, the other end of O, at *d'*, fig. 2, is thrown forward, and at the same time the lever N is thrown forward, pressing the sliding boxes *t t'* together by means of the connecting-rods *s s'*, and thereby carrying the gear-wheels *n n'* into gear with the wheel 1, which causes *n n'* to revolve in opposite directions and carry the carriage up and down alternately by acting on the arm J.

The arm J is attached to the rod *g* by a strap, *h*, which passes over the rod *g* and down the side of the

arm J, where it is held by the gib *i*, which is so formed with a projection at each end, as shown in fig. 3, as to hold the strap *h* against the arm J, and the gib is held in place by the key *j*, so that the whole may be easily detached from the carriage at pleasure, for repairs or otherwise.

By hanging arm J like a pendulum it is always in equipoise, and easily shifted by the force of the springs into engagement with either of the pinions, the same degree of force moving it in either direction.

By means of the adjusting-wedge it has a slight range of vertical adjustment, so that in any casual change of the relative position of the teeth of the racks and pinions they may be made to engage with certainty.

By means of the strap, wedged key, and gib, the arm is readily removable at a moment's notice, for repairs, shipment of the machine, &c., and as readily replaced.

For convenience in changing or removing the saw I shrink a collar onto the end of the shaft and turn it up true. I then fasten my saw to the face of the collar without passing any part of the shaft through the saw. This allows the saw to be removed without unshipping the shaft.

Collars have been shrunk onto shafts, but they have been used in such a manner as to be just the reverse of my method, and to necessitate passing the shaft through the saw to hang the saw to the collar, and also to necessitate unshipping the shaft to remove the saw; in other words, I turn a face on the collar on the outside from the shaft, instead of on the inside toward the shaft.

I do not claim the carriage nor the movement of the carriage, nor anything conflicting with the Evarts patent, having purchased of Mr. Evarts the right to use his invention so far as is necessary for the construction and use of my machine; but

What I do claim as my invention, and desire to secure by Letters Patent, is—

1. The combination of arm J, strap *h*, gib *i*, key *j*, feed-racks *e e'*, geared wheels *k k'*, guide *r*, springs *r'*, shafts F F' G, geared wheel 1, and sliding boxes *t t'*, all operating to produce the movement of the carriage regularly up and down by the face of the saw, as set forth.

2. The shingle-flipper U, consisting of the rod and prongs *p p'* and arm or lever *w*, acting in connection with the long hook T to tip shingles away from the saw.

WILLIS PORTER.

Witnesses:

HORACE S. SMITH,  
FRED. H. COOMBS.