

Nov. 1, 1932.

L. L. CHONG ET AL

1,885,231

CUTTING BLADE MOUNTING FOR GROUND WORKING IMPLEMENTS

Filed Aug. 18, 1931

Fig. 1

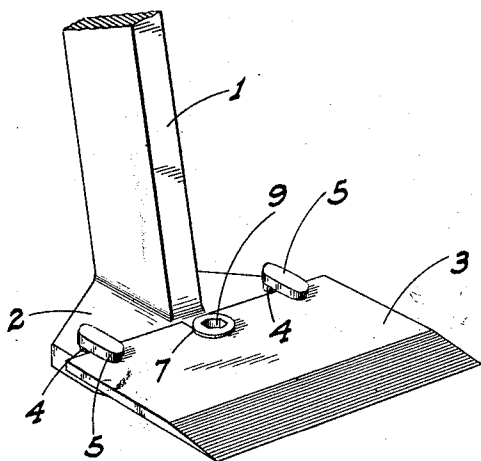

Fig. 2

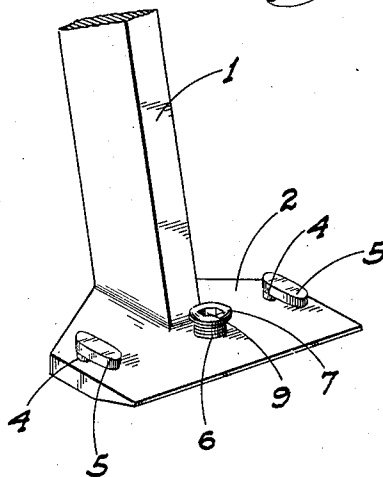

Fig. 3

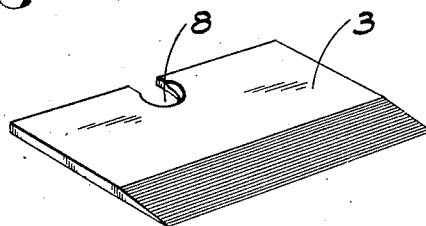
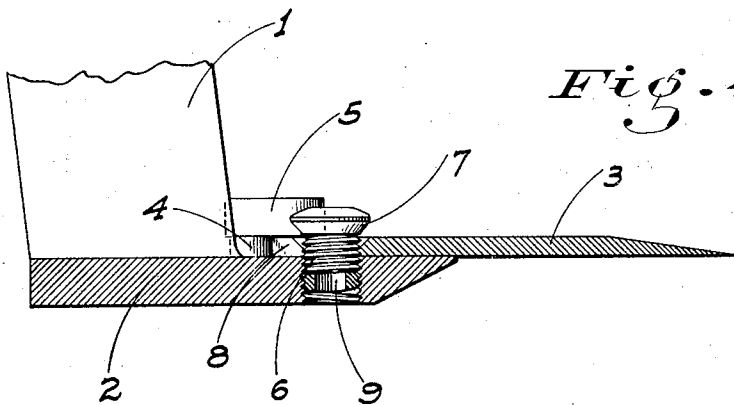

Fig. 4



INVENTORS

Jue L. Chong, Sam L. Chong
and Look L. Chong

BY

Paul W. W. W. W.

ATTORNEY

UNITED STATES PATENT OFFICE

LOOK L. CHONG, JUE L. CHONG, AND SAM E. CHONG, OF ISLETON, CALIFORNIA

CUTTING BLADE MOUNTING FOR GROUND WORKING IMPLEMENTS

Application filed August 18, 1931. Serial No. 557,776.

This invention relates to the mounting of the cutting blades of ground working implements of the rotary type and particularly represents improvements over the structure shown in our Patent No. 1,816,210 dated July 28, 1931. It is necessary to frequently resharpen the blades and in the interests of economy it is customary after the blades have been resharpened several times by grinding, so that their chisel edges are worn down and relatively blunt, to restore the desired angle of these edges prior to subsequent re-grinding operations. This is accomplished in connection with a reheating of the blades and as a result of such reheating we found from experience that very frequently the slots in the back of the blade provided therein for engagement with the locating rivets on the supporting pad, were no longer in proper alinement with the rivets and the slots had to be reamed out to make a new fit before the blades could be again mounted in place.

It is therefore the principal object of the present invention to mount the blades in such a manner that while all the advantages of the previous structure are retained, the disadvantages as above outlined are avoided and the blades can always be remounted regardless of any warping which may be had due to the reheating.

We also found that the clamping bolt or screw as provided with the previous structure tended to fracture when tightened up and a further object of this present invention is to construct this bolt so that this difficulty is remedied.

A further object of the invention is to produce a simple and inexpensive device and yet one which will be exceedingly effective for the purpose for which it is designed.

These objects I accomplish by means of such structure and relative arrangement of parts as will fully appear by a perusal of the following specification and claims.

In the drawing similar characters of reference indicate corresponding parts in the several views:

Fig. 1 is a perspective view of the blade and supporting standard assembled.

Fig. 2 is a perspective view of the supporting unit alone.

Fig. 3 is a similar view of the blade alone.

Fig. 4 is a sectional elevation of the assembled parts.

Referring now more particularly to the characters of reference on the drawing, each unit comprises a rigid standard 1 in the form of a rectangular bar which is adapted to be bolted onto the rotating structure in radial relation to the axis of rotation as usual. Projecting forwardly from one end of the standard is a rigid base pad 2 preferably disposed at an obtuse angle to the standard in the direction of rotation of the structure. In the transverse plane of said structure however the pad is disposed at right angles to the standard. The pad forms the support for a relatively large rectangular blade 3 which is adapted to be mounted on the pad in symmetrical relation thereto in front of the standard.

A pair of L head members is rigidly secured in the pad in transversely spaced relation to the standard in such a position that the back of the blade will engage the shanks or stems 4 of the members while the heads 5 will overhang the blade and extend forwardly as shown. To make a fairly smooth fit the height of the shanks between the heads and the pad is substantially equal to the thickness of the blade. The heads are of relatively large size and are of a substantial and non-yielding nature so that they may function to prevent possible upward warping of the blades during operation without danger of snapping off.

Disposed centrally between the members and forwardly of the same a special form of bolt or screw 6 is mounted in the pad. The head 7 of this screw is under-cut on a taper and is clear of the blade engaging surface of the pad. This head is adapted to engage a similarly shaped slot 8 centrally positioned in the blade and cut in from the back edge of the same. The head engaging portion of the slot is disposed so that when the screw head is clampingly engaged with the blade the back of the blade will be snugly held against the rigid shanks.

The outer end of the screw does not project outwardly of the pad so that it will not be worn away by contact with the ground. A non-circular bore 9 is provided in the screw from end to end, said bore being adapted
5 to receive a turning tool. By reason of this feature of construction not only may the screw be manipulated from end to end but a stronger grip with the turning tool may
10 be obtained since the tool engages the screw from one end to the other. This distributes the strains over the entire length of the screw and avoids any tendency of the relatively weakened threaded portion to fracture.

When removing the blade the screw is not
15 entirely removed from the pad but only sufficient to allow the blade to be slid from under the screw head. The screw then forms a locating means for the blade when it is replaced and assures the slot being properly disposed
20 relative to the screw without any try-and-fit operations having to be resorted to.

From the foregoing description it will be readily seen that we have produced such a device as substantially fulfills the objects of
25 the invention as set forth herein.

While this specification sets forth in detail the present and preferred construction of the device, still in practice such deviations from
30 such detail may be resorted to as do not form a departure from the spirit of the invention, as defined by the appended claims.

Having thus described our invention what we claim as new and useful and desire to secure by Letters Patent is:
35

Means to detachably secure a blade against a supporting pad, said pad having a tapped hole extending therethrough; said means comprising a headed screw projecting through
40 the blade and threaded into the pad-hole; said screw having a non-circular bore extending completely therethrough to receive a turning tool of similar form whereby upon the insertion of the tool, any dirt in the bore will be
45 pushed out of the same.

In testimony whereof we affix our signatures.

LOOK L. CHONG.
JUE L. CHONG.
SAM L. CHONG.

50

55

60

65