

(No Model.)

3 Sheets—Sheet 1.

M. L. E. DUVAL.
METALLIC BRIDGE.

No. 384,197.

Patented June 5, 1888.

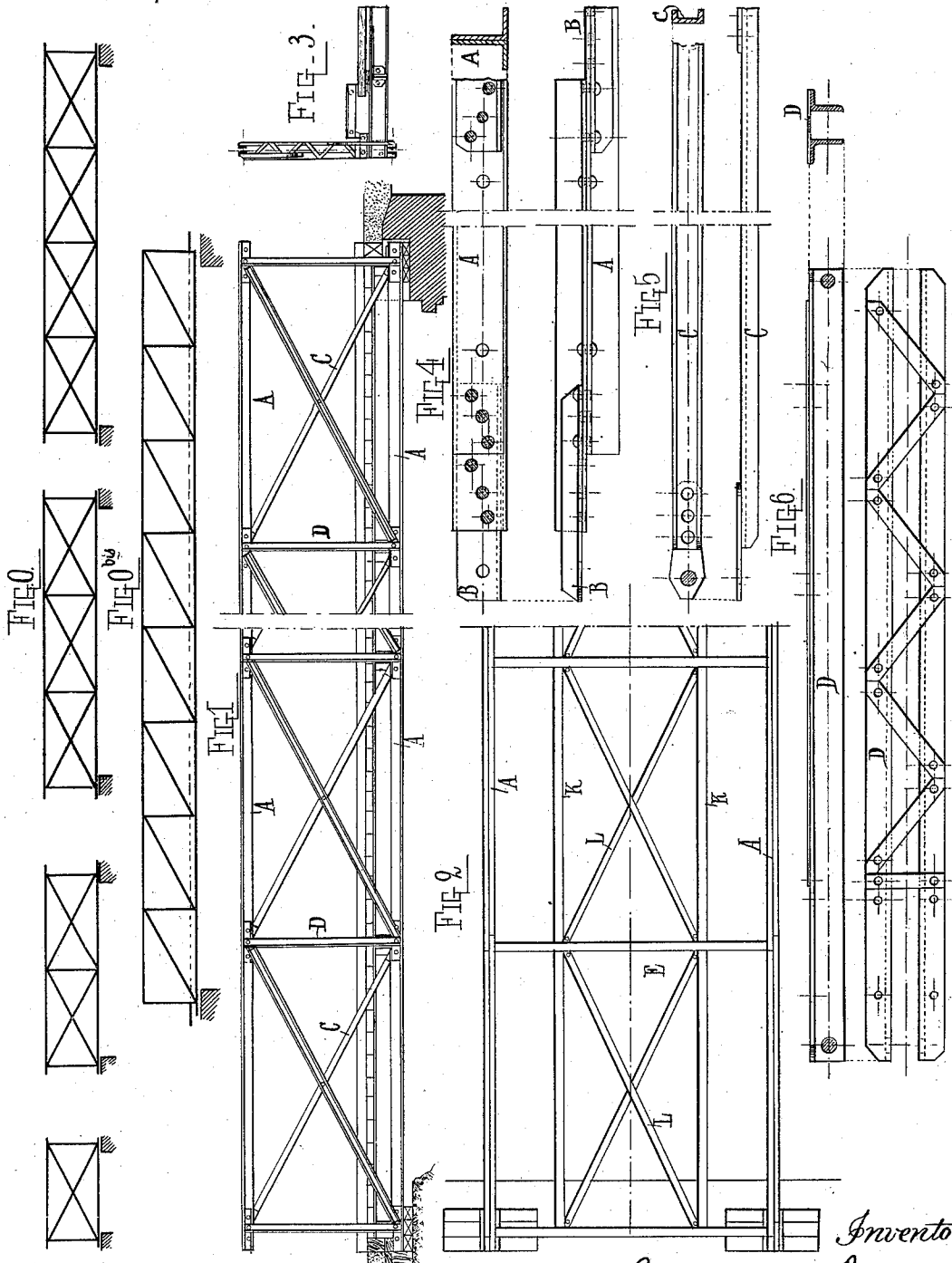

Attest
 c. j. Heald.
 Philip Hanna

Inventor:
 Martin L. E. Duval
 by A. Pollok
 his attorney.

(No Model.)

3 Sheets—Sheet 2.

M. L. E. DUVAL.

METALLIC BRIDGE.

No. 384,197.

Patented June 5, 1888.

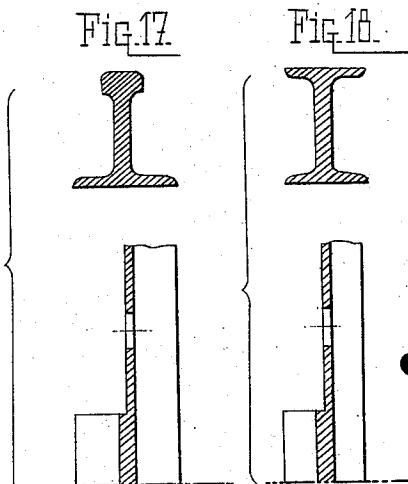
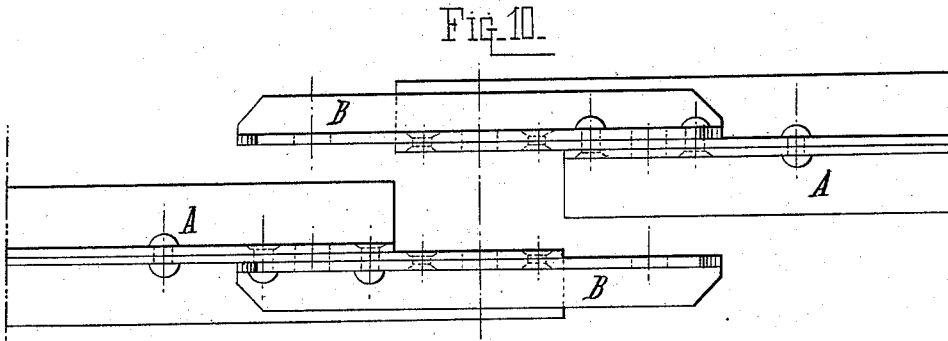
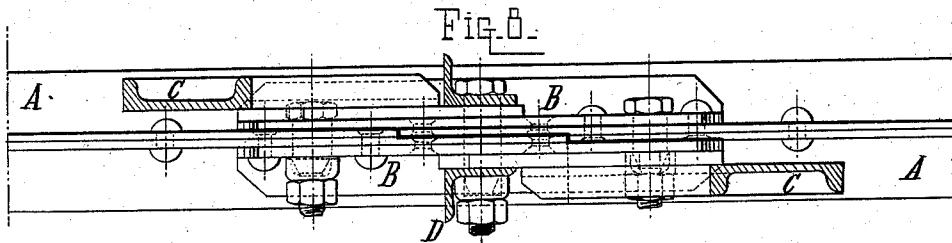
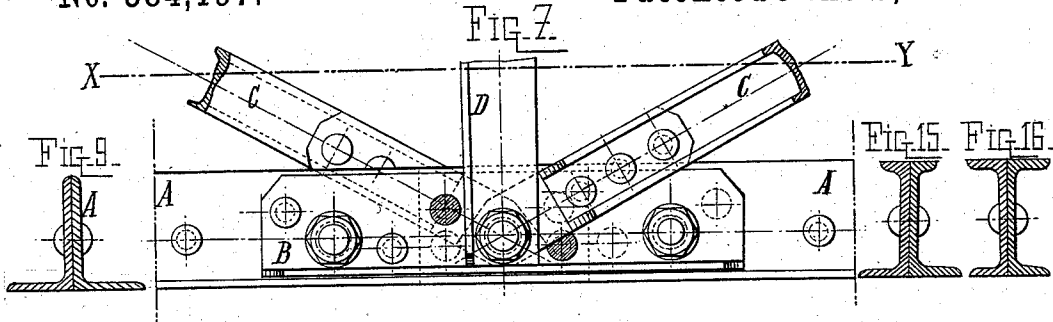

Attest.
C. J. Hendrick.
Philip Mauer.

Inventor:
Martin L. E. Duval.
by A. Pollak.
his attorney.

(No Model.)

3 Sheets—Sheet 3.

M. L. E. DUVAL.
METALLIC BRIDGE.

No. 384,197.

Patented June 5, 1888.

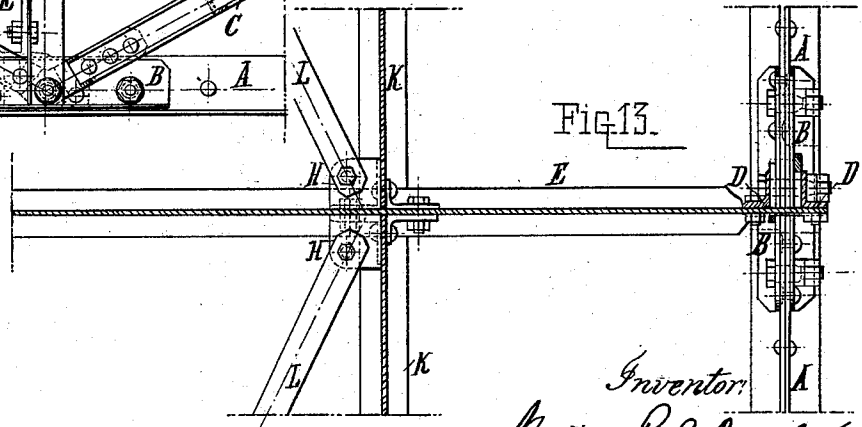
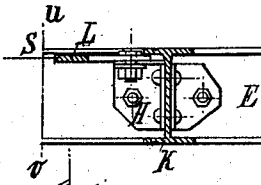
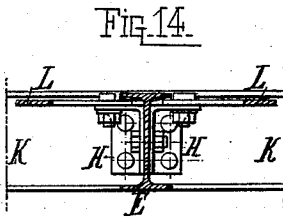
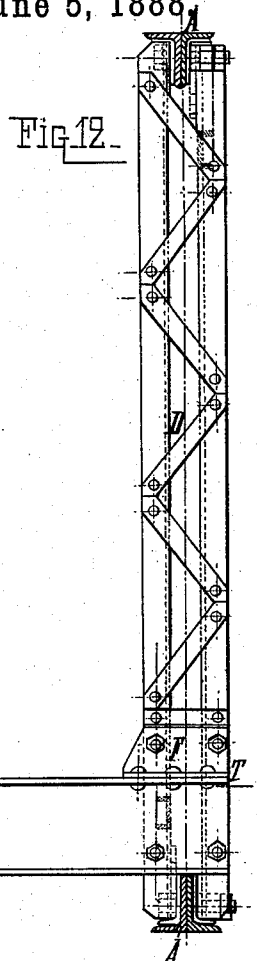
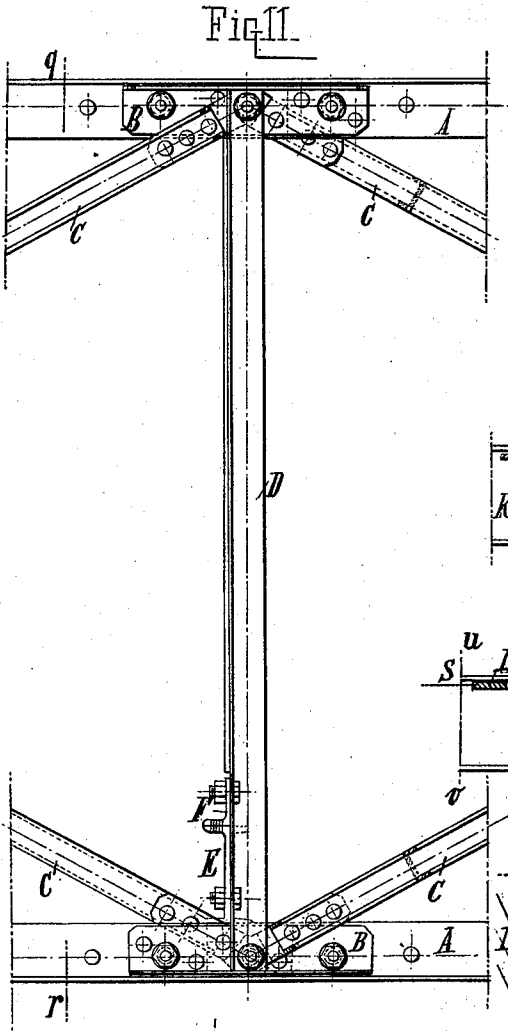

Attest
 C. J. Hedrick.
 Philadelphia.

Inventor:
 Martin L. E. Duval
 by A. S. Pottor
 his attorney

UNITED STATES PATENT OFFICE.

MARTIN LÉONARD EDMOND DUVAL, OF PARIS, FRANCE, ASSIGNOR TO THE
COMPAGNIE DE FIVES-LILLE, OF SAME PLACE.

METALLIC BRIDGE.

SPECIFICATION forming part of Letters Patent No. 384,197, dated June 5, 1888.

Application filed February 8, 1888. Serial No. 263,419. (No model.) Patented in France April 19, 1886, No. 175,623, and in
Belgium April 27, 1886, No. 72,896.

To all whom it may concern:

Be it known that I, MARTIN LÉONARD EDMOND DUVAL, a citizen of the Republic of France, residing at Paris, in the said Republic, have invented certain new and useful Improvements in Dismountable Metallic Bridges with Rectilinear Elements, (for which I have obtained patents in France April 19, 1886, No. 175,623, and Belgium April 27, 1886, No. 72,896,) of which the following specification is a full, clear, and exact description.

This invention relates to the construction of metallic dismountable and portable bridges of varied length by means of elements of a small number of types, straight, rigid, identical with each other, and interchangeable.

The new or improved bridges comprise, like ordinary metallic bridges, two principal girders or compound beams which support the flooring of the way, which can be placed between the girders at their lower part or above at their upper part.

The girders are of the very open lattice type, and the flooring which supports the way is composed of cross-girders, stringers underlying an ordinary roadway or rails, and horizontal diagonals.

The invention is particularly characterized by the new arrangement of these kinds of pieces which make up the principal girders—namely, the elements of the chords, the lattice-bars, and the vertical posts—as well as by the mode of arranging and connecting them with each other and with the cross girders.

Figure 0 consists of diagrams of different lengths of girders of the type specially contemplated by the invention, composed of one, two, three, and four panels, respectively. Figs. 1, 2, and 3 are, respectively, a side elevation, plan, and cross-section of a truss constructed in accordance with the invention and adapted to receive at its lower part a way for ordinary wagons. In this truss the girders form a railing, and it is in this disposition the application of which is particularly in view for light bridges. Fig. 4 consists of a side elevation, plan, and a cross-section of the element of the chords; and Figs. 5 and 6, similar views of one of the lattice-bars and one of the

vertical posts, respectively. Figs. 7 and 8 are detail views, in elevation and in plan, partly in horizontal section, respectively, illustrating the joint between the chords, lattice-bars, and posts; Fig. 9, a cross section of the element of the chords; Fig. 10, a detail view, in plan, illustrating the manner of lapping the ends of the chord elements; Figs. 11, 12, and 13, partial views, in elevation, cross-section, and horizontal section, of the truss shown in Figs. 1, 2, and 3; Fig. 14, a detail view, in longitudinal section, illustrating the connection between the stringers and the horizontal diagonals; and Figs. 15, 16, 17, and 18, sectional views illustrating different forms of iron which can be used in the chords.

Elements of the chords.—As will be seen by reference to Figs. 4, 7, 8, 9, 10, 11, 12, and 13, the elements of the chords A are each formed of two angle-irons of equal length riveted together back to back, and so arranged that one projects beyond the other at either end. A connecting-iron, B, designed to break the joint between two elements, is riveted to each end of the elements on the outside of the longer branch. This connecting-iron extends equally on either side of the point where the connection is made with the other portions of the girder, and projects beyond the longer branch of the chord element, as this projects beyond the shorter branch, thus forming, as it were, a series of steps at each end of the element, those at opposite ends facing in opposite directions. By placing the ends of any two elements, as shown in Fig. 10, therefrom and bringing them together the webs of the angle-bars come into line, the step-like projections fitting together, as shown in Fig. 7. The two elements are connected together by three pins through the connecting-irons B and the webs of the chord elements A, the central pin serving also to connect the lattice-bars and the vertical posts with each other and with the chords. This combination, which is one of the essential points of the invention, assures a great rigidity in the chords and a perfectly firm joint, since in consequence of the lapping of parts there is never more than half the chord interrupted at any point, and the section cut as well as that

removed by punching the pin-holes is mainly or quite compensated for by the connecting-irons B, which are permanently fastened to the webs of the chord elements.

5 In place of using two angle-bars for the chord elements, flanged iron of a form capable of being placed back to back may be used—such, for example, as shown in Figs. 15 and 16—
10 or a single flanged bar may be used—such as shown in Figs. 17 and 18—half of the vertical section being removed at one end, as indicated in the lower part of Figs. 17 and 18, in order that the described joints may be made.

Lattice-bars.—The lattice-bars are formed
15 each of [] or channel-iron, Figs. 5, 7, 8, and 11, terminated by flat eye-plates, which may be riveted on or may be formed by the removal of the flanges for a suitable distance. Two of the bars and the vertical post are connected,
20 as before stated, with the web of the chords by a single pin, one bar being applied on one side and the other on the opposite side of the web. (See Figs. 7 and 8.) The lattice or diagonal portion of the panels may be formed by bars
25 which cross or by bars inclined in the same direction.

The lattice-bars might be of angle-iron or they might be **L** or **I** shaped in section, or they might be of other rigid forms.

30 *Vertical posts.*—The vertical posts D, Figs. 6, 7, 8, 11, 12, and 13, are composed of two angle-bars, which embrace the lattice-bars at their junction with the chords, and are connected together by a light lattice, Figs. 6 and
35 12, applied to their side flanges, and of such width as properly to space the angle-bars. They have thus a transverse stiffness sufficient, in connection with their attachment to the cross-girders, to assume the vertical position
40 of the girders without the assistance of inclined lateral braces.

In another application of even date I have described certain means whereby the height of girders can be varied while employing elements of constant length for the lattice-bars
45 and the chords. These means are applicable to bridges of the present construction.

Connection of the cross-girders with the principal girders.—The cross girders E, Figs. 11, 12,
50 13, and 14, have the section of double T. They rest directly on the chords A of the girders, and at the ends, the flanges on one side being removed, are applied against the side flanges of the vertical posts D, to which they are
55 bolted. To increase the height of the connection, an angle-piece, F, is riveted to the remaining top flange of the cross girders and bolted to the post. This connection of parts assumes a perfectly vertical position to the
60 principal girders without other support.

Connection of the stringers and the horizontal diagonals with the cross-girders.—As shown in

Figs. 2 and 3, the frame-work supporting the way is constituted, as ordinarily, by the cross-
65 girders E, two lines of stringers, K, and a system of horizontal diagonal bracing, L, only the horizontal bracing exists simply between the two lines of stringers, and is connected
70 with these latter, as also with the cross-girders, by triple or three-sided angle-pieces, H, Figs. 12, 13, and 14, which serve at the same time for the connection of the stringers K with the cross-girders. The horizontal member of each
75 piece H has an eye, and to it the horizontal diagonal L (composed of a flat bar) is secured. This disposition, which forms a part of the invention, has for its object partly to leave the
80 bottom of the stringers perfectly free, in order that the bridge may be rolled on said stringers, and partly to permit the placing of the horizontal diagonals L at such height as not
85 to penetrate into the floor of the roadway. This arrangement of the horizontal diagonals permits, moreover, the use of as many intermediate stringers as may be required under
the roadway.

I claim as my invention or discovery—

1. In a trussed girder, the chord elements, each composed of irons secured together so that one projects beyond the other at each end,
90 and connecting-irons projecting beyond the longer branch of the element, thus forming stepped projections, the ends of adjacent chord elements being overlapped and secured together, substantially as described. 95

2. The double posts constituted by two angle-bars turned back to back, connected by cross-pieces and spaced, in combination with a chord, lattice-bars or diagonals lapped on the web of said chord, and pins—one at each
100 end of the posts—connecting them with the said chord and said lattice bars or diagonals, substantially as described.

3. In a truss or bridge, and in combination with the principal girders having vertical
105 posts, the cross-girders of **I**-iron having the flanges on one side removed and fitted against the sides of said posts, and the angle-pieces between the tops of the cross girders and the sides of said posts, substantially as described. 110

4. In a truss or bridge, and in combination with the principal girders, the cross-girders and the stringers, the horizontal diagonals attached to said stringers and said cross-girders
115 by the triple or three-sided angle-pieces, substantially as described.

In testimony whereof I have signed this specification in the presence of two subscribing witnesses.

MARTIN LÉONARD EDMOND DUVAL.

Witnesses:

GIRAL,
J. B. BOURNE.