

Oct. 21, 1969

P. A. L. POSSO
FILM SPOOL BOX

3,473,649

Filed July 5, 1967

2 Sheets-Sheet 1

Fig. 1

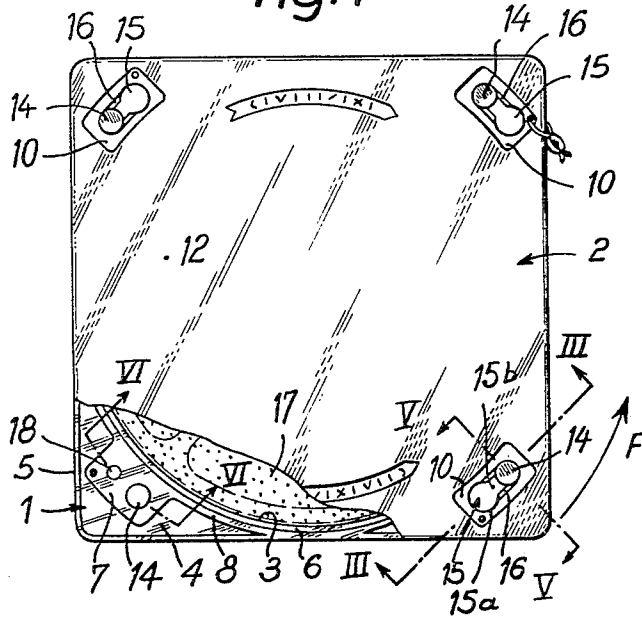
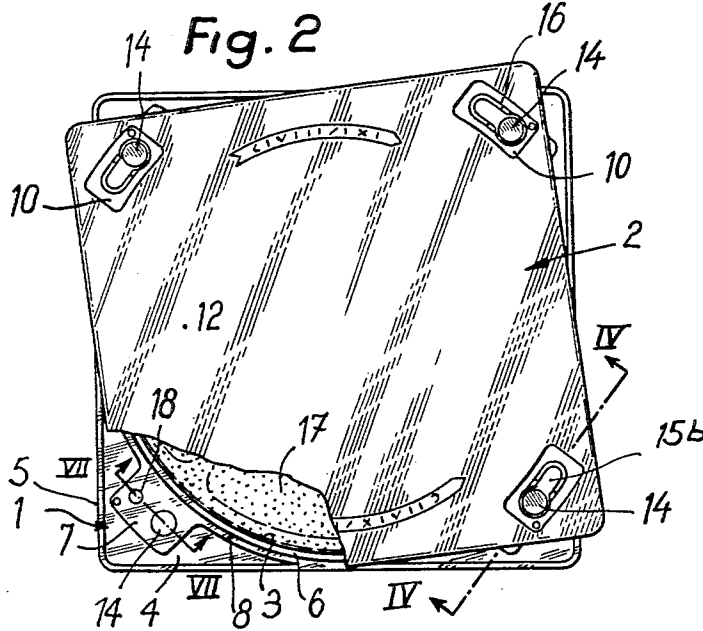

Fig. 2



INVENTOR:
Pierre A. L. Posso
BY *Spencer & Kaye*
Attorneys

5

6

6. A box as claimed in claim 1, wherein each corner thereof is provided with a locking device.

3,076,577	2/1963	Craig -----	220—40
3,169,682	2/1965	Hollingsworth -----	206—52 X
3,297,153	1/1967	Fattori -----	206—52

References Cited

UNITED STATES PATENTS

5

MARTHA L. RICE, Primary Examiner

U.S. Cl. X.R.

806,665	12/1905	Henderson et al.	
1,132,766	3/1915	Delaney -----	206—59
1,527,746	2/1925	Miller et al. -----	220—40

220—40