

No. 626,725.

Patented June 13, 1899.

J. W. & E. A. SCOTT.

EXCAVATING MACHINE OPERATED BY TRACTION.

(Application filed June 30, 1898.)

(No Model.)

4 Sheets—Sheet 1.

Fig. 1.

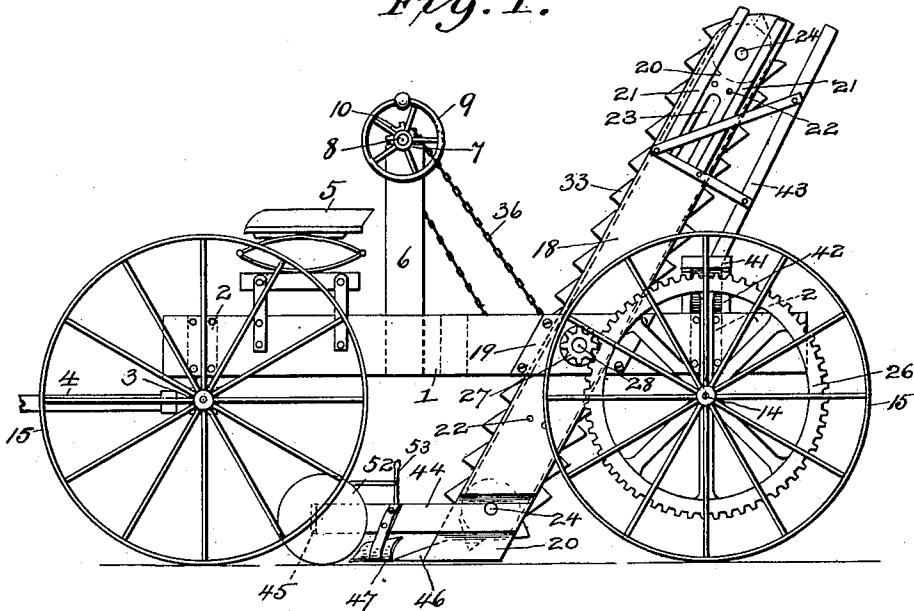
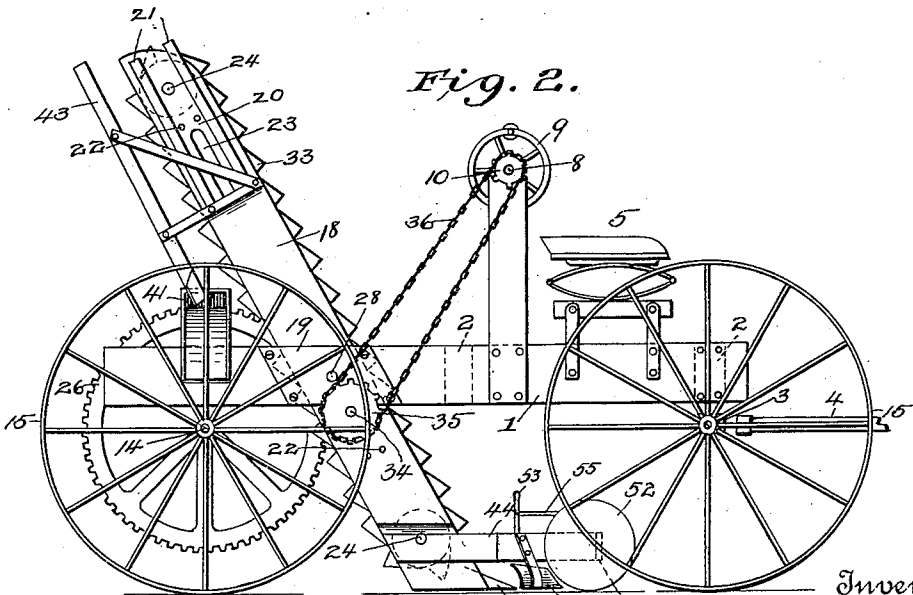

Fig. 2.



Witnesses  
*Just N. Blackwood*  
*Hartwell P. Heath*

Inventors  
 46 47 45 *James W. Scott*  
*Emmett A. Scott*  
 by *J. N. Souwick*  
 Atty-Attorney

No. 626,725.

Patented June 13, 1899.

J. W. & E. A. SCOTT.  
EXCAVATING MACHINE OPERATED BY TRACTION.

(Application filed June 30, 1898.)

(No Model.)

4 Sheets—Sheet 2.

Fig. 7.

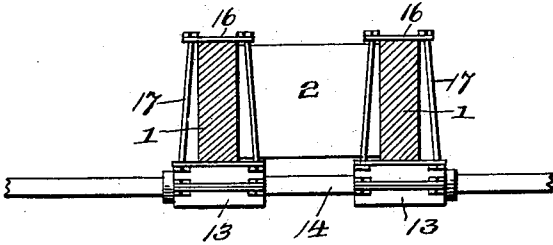

Fig. 3.

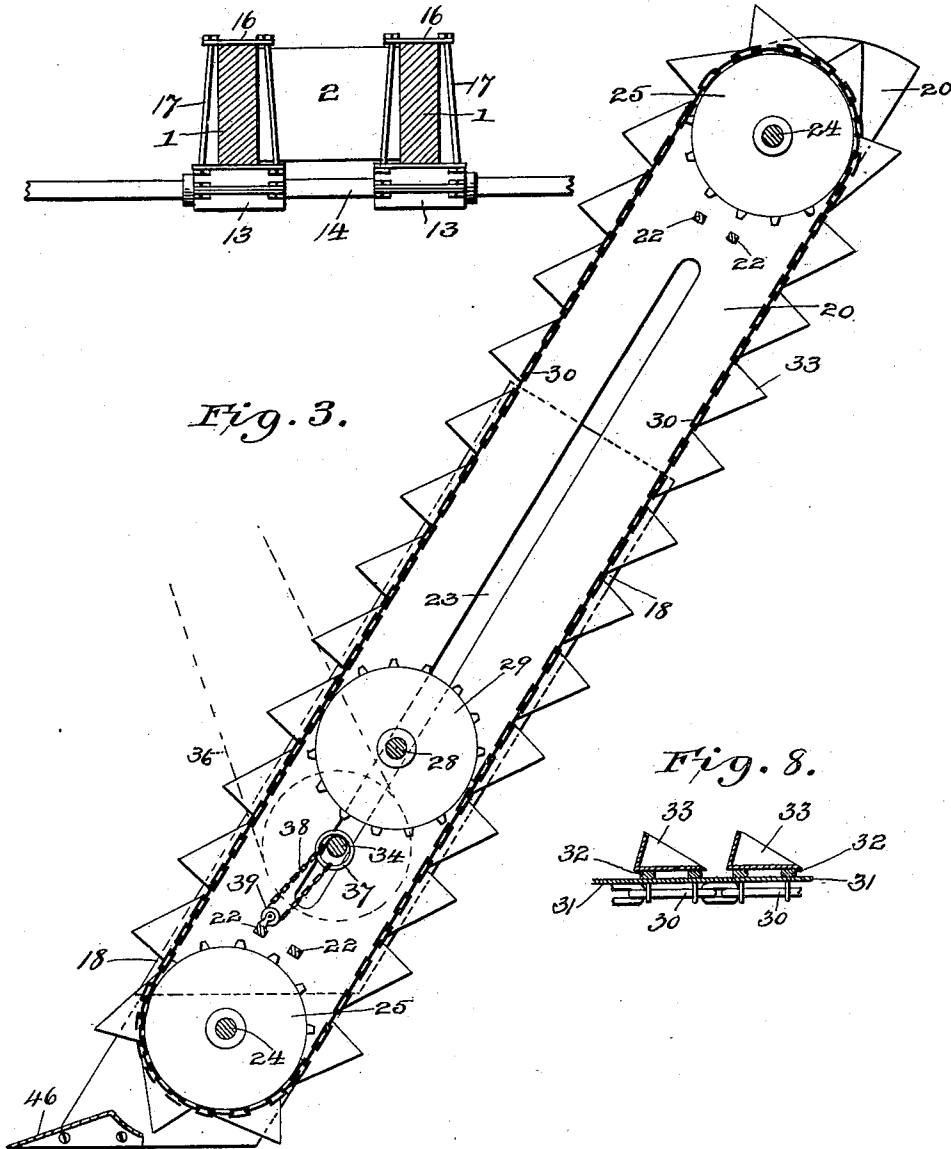
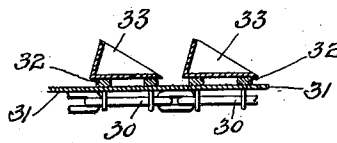

Fig. 8.



Witnesses  
Jost N. Blackwood  
Hartwell O. Heath

James W. Scott Inventors  
Ernest A. Scott  
by D. A. Soule Attorney  
Advo.

No. 626,725.

Patented June 13, 1899.

J. W. & E. A. SCOTT.

EXCAVATING MACHINE OPERATED BY TRACTION.

(Application filed June 30, 1898.)

(No Model.)

4 Sheets—Sheet 3.

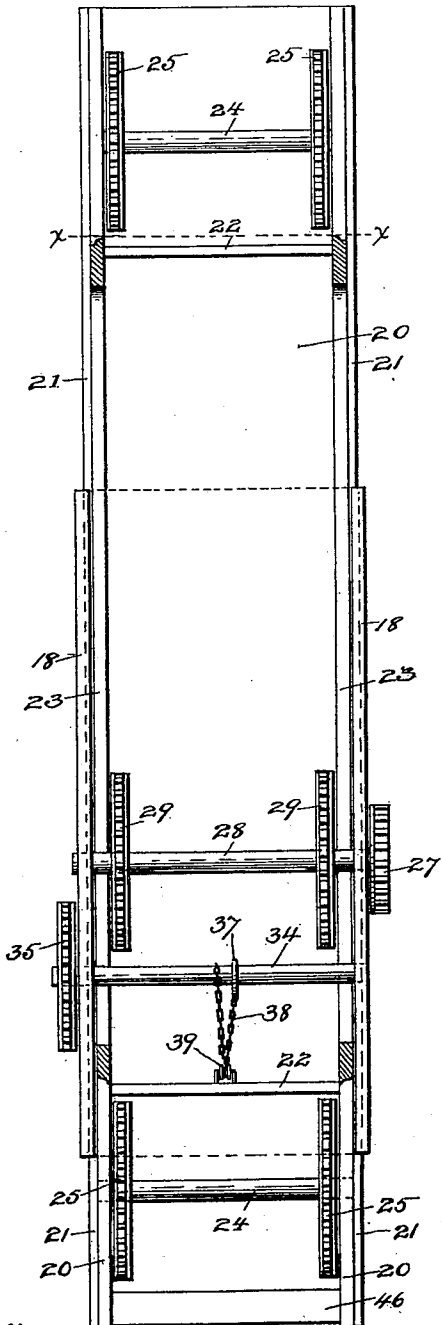

Fig. 5.

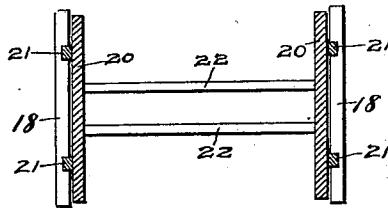

Fig. 4.

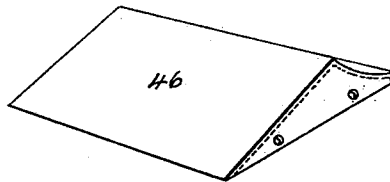

Fig. 6.

Witnesses  
*Josef S. Blackwood*  
*Hartwell P. Heath*

Inventors  
*James W. Scott*  
*Ernest A. Scott*  
 by *A. D. Gowick* Attorney

No. 626,725.

Patented June 13, 1899.

J. W. & E. A. SCOTT.

EXCAVATING MACHINE OPERATED BY TRACTION.

(Application filed June 30, 1898.)

(No Model.)

4 Sheets—Sheet 4.

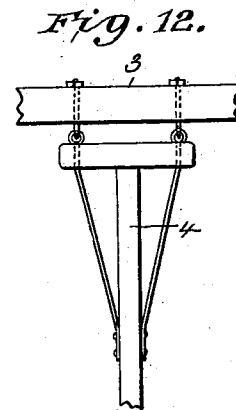
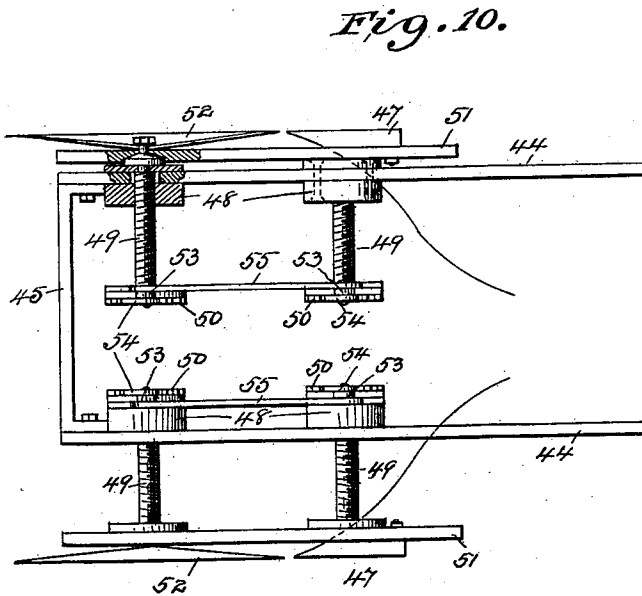
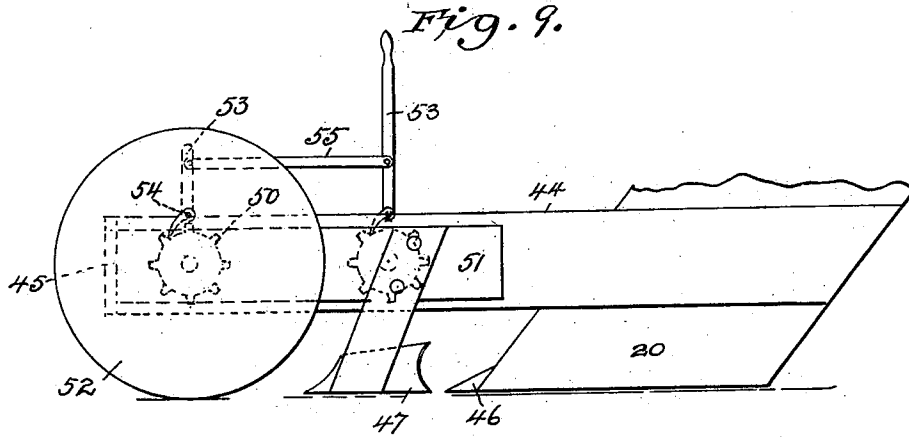

*Fig. 11.*



Witnesses  
*John Blackwood*  
*Hartwell P. Heath*

Inventors  
*James W. Scott*  
*Ernest A. Scott*  
 by *D. A. Louieck*  
 atty. - Attorney

# UNITED STATES PATENT OFFICE.

JAMES W. SCOTT AND EARNEST A. SCOTT, OF MARION, OHIO.

## EXCAVATING-MACHINE OPERATED BY TRACTION.

SPECIFICATION forming part of Letters Patent No. 626,725, dated June 13, 1899.

Application filed June 30, 1898. Serial No. 684,873. (No model.)

*To all whom it may concern:*

Be it known that we, JAMES W. SCOTT and EARNEST A. SCOTT, citizens of the United States, residing at Marion, in the county of Marion and State of Ohio, have invented a certain new and useful Improvement in Excavating-Machines Operated by Traction, of which the following is a specification.

Our invention relates to excavating-machines operated by traction, especially ditching-machines, and has for its object to provide a strong, simple, cheap machine of few parts, having an adjustable double-plow attachment and carrier or elevator for receiving and disposing of the loosened earth in a rapid and perfect manner, said machine being practical, capable of operation with minimum draft, and adapted to adjust the working parts to the progress of the work and the increasing depth of the excavation. This object we accomplish in the manner and by the means hereinafter fully described in detail and particularly pointed out in the claims, reference being had to the accompanying drawings, in which like figures indicate like parts in all the views.

Figure 1 is a side elevation of our invention. Fig. 2 is an opposite side of same. Fig. 3 is a view of interior of elevator. Fig. 4 is a plan view of elevator. Fig. 5 is a view of elevator on line *x x*, Fig. 4. Fig. 6 is a detail view of scoop. Fig. 7 is a detail view of hubs and fastenings. Fig. 8 is a detail view of chain, canvas, cross-piece, and brackets. Fig. 9 is a detail view of loop and attachments. Fig. 10 is a top plan view of loop and attachments. Fig. 11 is a detail view of lever and tooth-wheel. Fig. 12 is a detail view of hole and coupling.

Our invention consists of two side beams 1, having cross-pieces 2 between them, one near each end and one in the middle, through which they are bolted. The front cross-piece 2 is pivotally secured by a bolt to an axle 3 on two wheels having the draft 4 immediately under the ends of the side beams 1, a brace running from the under side of the center cross-piece 2 to the bolt under the axle, where it is secured. On the side beams 1, near the front, a driver's seat 5 is provided. Bolted to the outside of and rising vertically from one of the side beams 1, within reach of

the driver's hand, is a standard 6, on top of which a bearing 7, provided with the usual lubricating devices, is secured. A shaft 8, 55 journaled in said bearing 7, carries on its inner end a crank-wheel 9 and on its outer end a small sprocket-wheel 10. The rear of the side beams 1 rests on a metal hub 13, inclosing a heavy iron or steel axle 14, carried by large 60 and strong wheels 15, and the side beams 1 are each firmly secured to said axle 14 through the hubs 13 by metal straps 16 and tie-rods 17. Just forward of the rear axle 14, on the inside of each of the side beams 1, is a stand- 65 ard 18, inclined downwardly diagonally toward the front and securely bolted to the side beam 1 through a metal plate 19, placed on the outside of each side beam 1. Between the standards 18 are two slides 20, provided on the 70 outside with guides 21, complementary to the inside formation of the standards 18. The slides 20 are held in place by suitable cross-bars 22, preferably of square metal bars, shouldered near their ends, which pass through the 75 slides 20, and then have nuts screwed on them, two at a suitable distance from the top and two at a like distance from the bottom, one on each side. The slides 20 also have slots 23 running longitudinally from just below 80 the upper cross-bars 22 to just above the lower cross-bars 22. Two shafts 24, one near the top and the other at a like distance from the bottom, have their ends journaled in said slides 20 and extend across between the slides 85 20. These shafts 24 each carry two sprocket-wheels 25, one on each side next the slides 20. A large cog-wheel 26 is mounted on the rear axle 14 on the side of the side beams 1 opposite that on which is the standard 6. This 90 cog-wheel 26 meshes with a pinion 27, mounted on the end of a shaft 28, passing through the metal plate 19, side beam 1, standard 18, slots 23, and the other standard 18 and side beam 1, suitable bearings being provided. 95 This pinion-shaft 28 carries two sprocket-wheels 29, one on each side just inside the slides 20, and chains 30 connect these sprocket-wheels 29 with the sprocket-wheels 25. A piece of canvas 31 or other suitable material 100 for excluding dirt is placed on chains 30, and upon the canvas 31, at suitable intervals, are placed cross-pieces 32, which are secured by bolts or clamps to the chains 30. Elevator-

buckets 33 are bolted or otherwise suitably secured to the cross-pieces 32. A shaft 34 has one end journaled in the standard 18 on the side of the pinion 27, passes through the slots 23 and opposite standard 18, and is furnished at its projecting end with a sprocket-wheel 35, which is connected by a chain 36 with the sprocket-wheel 10. To a movable collar 37 on shaft 34 one end of a chain 38 is securely fastened, the other end of the chain 38, after being passed through a pulley 39, attached to one of the lower cross-bars 22, being rigidly fastened to the shaft 34. An open-mouth trough 41 is placed transversely across the side beams 1, just behind the standards 18, and inclined slightly upward toward its closed end, its higher end supported by a brace bolted to the side beam 1. Rising from the rear side of the trough 41, behind the standards 18 and slides 20, is a flanged screen 43, supported on each side by a V-shaped brace, its open ends secured to one of said flanges and one side near the apex bolted to the standard 18 at its top.

Extending forward from the slides 20 on each side and securely bolted thereto is a piece 44, of plate or boiler iron or other suitable material of proper size, the forward ends of the pieces 44 being connected by a cross-piece 45, of like material, having angled ends securely bolted to the pieces 44. Extending across between the pieces 44 and securely bolted to them is the metallic scoop 46, which receives the dirt from the plow 47 and delivers it to the buckets 33. Two metal bosses 48 of proper size, provided with screw-threaded holes through their centers, are securely bolted at a suitable distance apart to the inside of each of the pieces 44, the holes in the bosses 48 registering with like holes in the pieces 44. Working in the holes through the bosses 48 are heavy metal screws 49, to the inner ends of which are attached toothed wheels 50 and to the outer ends of which are secured metal plates 51. To the outside of each of the plates 51 are fastened a colter 52 in front and a plow 47 behind. The toothed wheels 50 are provided with levers 53, having dogs 54, adapted to engage the toothed wheels 50 in either direction. The two levers 53 on each side are connected by a bar 55, and the two levers 53 behind are longest and serve as handles to operate the toothed wheels 50.

The operation of our invention is as follows: The levers 53, by means of the two in the rear, are used to turn the toothed wheels 50 until the plates 51, carrying the colters 52 and plows 47 with them, are farthest apart, the slides 20 being lowered by the driver as the machine starts by the crank-wheel 9 sufficiently to enable the plows 47 to take good hold. As the machine moves the plows 47 throw the dirt toward the middle upon the scoop 46 until it is pushed up and over and the buckets 33 receive it. The rear axle 14 revolves the large cog-wheel 26, which turns

the pinion 27 in the opposite direction, and through the pinion-shaft 28, sprocket-wheels 29, chain 30, and sprocket-wheels 25 raises the buckets 33 and empties them backward upon the screen 43 and trough 41, which latter conducts the dirt off to one side. When a sufficient distance has been traversed, the driver raises the slides 20 by means of the crank-wheel 9, turns the machine, lowers the slides 20 in the same way until the plows again take hold, and, retracing the furrow already made, deepens the excavation, throwing the dirt this time on the opposite side from the first. These operations are repeated until the excavation is sufficiently deep. If the soil is loose or if for any other reason straight sides are not desirable, the colters 52 and plows 47 may at each successive operation be brought nearer together by means of the levers 53, forming a ditch with sides like steps.

Having thus described our invention, what we claim as new, and desire to secure by Letters Patent, is—

1. In an excavating-machine, a frame carried on four wheels, an elevator slidably supported by said frame, buckets fixed on an endless chain in said elevator, laterally-adjustable plows secured at the bottom of said elevator, and means for operating same, substantially as shown and described.

2. In an excavating-machine consisting of a frame carried on four wheels, an elevator slidably supported by said frame, buckets fixed on an endless chain in said elevator, and a frame secured to the bottom of said elevator, colters and plows adjustably secured to each side of said last-named frame, said colters and plows adapted to be moved simultaneously from or toward each other, and means for operating the same, substantially as shown and described.

3. In an excavating-machine provided with adjustable colters and plows, a frame carried on four wheels, and an elevator slidably supported by said frame, said elevator consisting of two inclined standards, two side pieces provided with guides on the outside adapted to slide up and down between said standards, said side pieces held in place by cross-bars at top and bottom and having slots, shafts between said side pieces at top and bottom provided with sprocket-wheels at each end, a cog-wheel on rear axle, a pinion meshing with said cog-wheel, a pinion-shaft passing through said slots and provided with a sprocket-wheel on each side just inside said side pieces, chains connecting the three sprocket-wheels on each side, a dirt-proof cover on said chain, cross-pieces secured to said chain over said cover, elevator-buckets secured to said cross-pieces, a shaft passing through said slots below said pinion-shaft and provided with a sprocket-wheel on its projecting end, a loose sliding collar on said shaft, a pulley secured to one of the lower cross-bars, a chain passing through said pulley and having one end secured to said collar and the other end to said

shaft, a short shaft suitably mounted near the driver and provided at one end with a crank-wheel and at the other end with a small sprocket-wheel, and a chain connecting said two last-named sprocket-wheels, and means for operating the same, substantially as shown and described.

4. In an excavating-machine consisting of a frame, supporting-wheels for said frame, and an elevator slidably supported by said frame, a loop of boiler-iron having its yoke end composed of a single piece with angled ends securely bolted to the side pieces of said loop, said loop firmly secured at its open end on each side of the lower part of said elevator an inclined scoop firmly secured between the sides of said loop, bosses secured on each side to the inside of said loop, said bosses provided with screw-threaded holes registering with like holes in the sides of said loop, screws working in said bosses, toothed wheels secured to the inner ends of said screws, levers provided with dogs and attached to said toothed wheels, bars connecting said levers, plates attached to the outer end of said screws, colters and plows attached to said plates, and means for operating the same, substantially as shown and described.

5. In an excavating-machine, a frame, supporting-wheels for said frame, a coupling-pole secured to the middle part of the front axle, inclined standards supported by said frame, slides arranged between said standards and provided with slots, cross-bars between said slides, shafts between said slides at top and bottom, two sprocket-wheels on each of said shafts, a cog-wheel on the rear axle, a pinion meshing with said cog-wheel, a pinion-shaft passing through said slots, two

sprocket-wheels on said pinion-shaft, a chain connected with the three sprocket-wheels on each side, a dirt-proof cover on said chains, cross-pieces secured to said chains over said cover, buckets secured to said cross-pieces, a shaft passing through said slots below said pinion-shaft and projecting at one end beyond said frame, a sprocket-wheel on the projecting end of said shaft, a loose collar on said shaft, a pulley attached to one of the lower cross-bars, a chain passing through said pulley and having one end fastened to said collar and the other end fastened to said shaft, a short shaft mounted near the driver, a crank-wheel on one end of said short shaft and a small sprocket-wheel on the other end of said shaft, a chain connecting the two last-named sprocket-wheels, two plates projecting forward from the bottom of said slides, their forward ends rigidly connected by a cross-piece, an inclined scoop secured between said plates, bosses secured to the inside of said plates on each side, said bosses provided with screw-threaded holes registering with like holes in said plates, screws working in said holes, toothed wheels secured to the inner ends of said screws, levers provided with dogs and attached to said toothed wheels, bars connecting each pair of said levers, plates secured to the outer ends of said screws and colters and plows secured to said last-named plates, substantially as shown and described.

In testimony whereof we hereto affix our signatures in the presence of two witnesses.

JAMES W. SCOTT.  
EARNEST A. SCOTT.

Witnesses:

J. B. VIRDEN,  
JAMES I. BENTLY.