

(19) World Intellectual Property Organization  
International Bureau



(43) International Publication Date  
18 January 2001 (18.01.2001)

PCT

(10) International Publication Number  
WO 01/03810 A2

(51) International Patent Classification<sup>7</sup>: B01D 51/00, 1/00

(21) International Application Number: PCT/CA00/00807

(22) International Filing Date: 7 July 2000 (07.07.2000)

(25) Filing Language: English

(26) Publication Language: English

(30) Priority Data:  
2,277,449 7 July 1999 (07.07.1999) CA

(71) Applicant and

(72) Inventor: MOUNT, Dennis, William [CA/CA]; 22  
Antares Drive, Unit M, Nepean, Ontario K2E 7Z6 (CA).

(81) Designated States (*national*): AE, AG, AL, AM, AT, AU, AZ, BA, BB, BG, BR, BY, BZ, CA, CH, CN, CR, CU, CZ, DE, DK, DM, DZ, EE, ES, FI, GB, GD, GE, GH, GM, HR, HU, ID, IL, IN, IS, JP, KE, KG, KP, KR, KZ, LC, LK, LR, LS, LT, LU, LV, MA, MD, MG, MK, MN, MW, MX, MZ, NO, NZ, PL, PT, RO, RU, SD, SE, SG, SI, SK, SL, TJ, TM, TR, TT, TZ, UA, UG, US, UZ, VN, YU, ZA, ZW.

(84) Designated States (*regional*): ARIPO patent (GH, GM, KE, LS, MW, MZ, SD, SL, SZ, TZ, UG, ZW), Eurasian patent (AM, AZ, BY, KG, KZ, MD, RU, TJ, TM), European patent (AT, BE, CH, CY, DE, DK, ES, FI, FR, GB, GR, IE, IT, LU, MC, NL, PT, SE), OAPI patent (BF, BJ, CF, CG, CI, CM, GA, GN, GW, ML, MR, NE, SN, TD, TG).

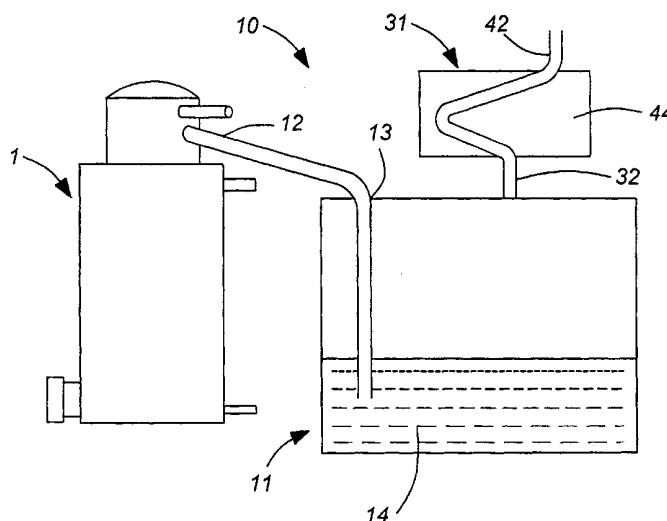
Published:

— Without international search report and to be republished upon receipt of that report.

(74) Agents: KENEFORD, L., Brooke et al.; Borden Ladner Gervais LLP, 1000-60 Queen Street, Ottawa, Ontario K1P 5Y7 (CA).

For two-letter codes and other abbreviations, refer to the "Guidance Notes on Codes and Abbreviations" appearing at the beginning of each regular issue of the PCT Gazette.

(54) Title: VAPOUR MANAGEMENT SYSTEM



(57) Abstract: A vapour recovery system and method for volatile chemicals which enhances the efficiency and safety of the process of recovering the vapour is disclosed. The volatile substance is vaporized in a distillation unit under the control of a computerised heating system. The resulting vapour is first directly condensed by bubbling the vapour directly into the liquid phase of that volatile substance. Any vapour that remains after having passed through said liquid phase accumulates above the liquid phase and is allowed to escape into a vapour management module. The vapour management module facilitates efficient condensation of the vapour by allowing heat exchange from the vapour to a material contained within said vapour management module. Upon cooling in the vapour management module, the vapour condenses, and can run back into the liquid phase through which it had passed when in the vapour phase. The vapour management module has an exhaust that is substantially free of the vapour.



WO 01/03810 A2

**VAPOUR MANAGEMENT SYSTEM  
BACKGROUND OF THE INVENTION**

5 Volatile solvents are used in many industrial processes in which the volatile solvent is used for cleaning purposes. As a result of such use the volatile solvent becomes contaminated with foreign matter. Due to the cost of such volatile solvents, environmental concerns, and the cost of disposing of such contaminated volatile solvents, it is desirable to maximize the use that can be made of the volatile solvent by removing the contamination from it by recycling it into the purified solvent form for further use in the industrial process.

10

In addition to industrial processes requiring purification and recovery of volatile solvents, there are also many industrial processes in which it is important to control the escape of vapour from volatile liquids. The escape of vapour from such volatile liquids represents an environmental and occupational health concern, and a financial cost in that the vapour is lost. The current procedure for preventing or reducing vapour loss is to provide a scrubbing system on tanks, containers or stacks in which the volatile liquid, or the vapour is stored. While the scrubbing system may reduce or even eliminate the environmental concerns of vapour loss, it does not overcome the cost of the loss of such vapour. Further, the used scrubbing material may in itself present an environmental disposal problem. Examples of such containers include oil storage tanks and gasometers. Other examples include the containment of vapours from stacks or from recycled solvents in processes such as gun-washing in automotive paint shops.

15  
20

Currently the common practice for purifying and recovering contaminated volatile solvents is distillation and condensation. Typically the solvent is boiled such that a vapour is formed. The vapour is then allowed to pass through a spiral or serpentine tube where it is cooled by heat exchange with air blown across the tube or with another liquid which flows around the outside of the tube. The heat exchange leads to condensation into the liquid phase inside the tube. This liquid phase then runs off into an open collection vessel. This method has a disadvantage in that as the vapour condenses in the tube, it has the potential for the build-up of back pressure within the distillation vessel which gives rise to a "champagne effect", i.e. vigorous boiling and cavitation, rather than controlled evaporation. This has the consequence of a potential safety hazard, reduced efficiency, and increased operating costs.

Further, the run off into an open collection vessel used in conventional systems leads to a loss of volatile solvent to the environment. This loss of solvent from an open collection vessel to the environment reduces the recovery of the solvent and causes an environmental hazard for operators around such tanks.

A further problem with conventional processes is the presence of uncondensed vapour in the collection vessel. Further, sealing the collection vessel, or the connection to the collection vessel from the distillation vessel in conventional systems causes pressure buildup unless vented. Such a pressure buildup or back pressure caused by uncondensed vapour in the collection vessel, or the conduit leading thereto can result in "foaming" in the distillation vessel. In order to prevent buildup of back pressure in the collection vessel and

consequently the distillation vessel, the collection vessel must be vented. Similarly, any vessel in which, or into which, a volatile solvent is placed requires a vent in order to avoid vapour lock. Conventional methods of venting lead to loss of volatile solvent in the form of vapour into the atmosphere, thereby further reducing the efficiency of conventional  
5 methods of distillation and condensation and creating an environmental hazard.

Hence, there is a need for a method of condensing a volatile vapour which will ideally prevent any significant loss of volatile solvent from the system, and enhance recovery and condensation of the vapour to liquid. The consequence of this increased  
10 recovery of volatile vapour is a decrease in the overall cost of the vapour recovery, improved safety of the system, and a reduction in potential environmental harm.

### SUMMARY OF THE INVENTION

Accordingly, the present invention provides a vapour recovery system for efficient  
15 and safe recovery of a vapour from a solvent comprising:

a distillation module comprising a distillation chamber for the solvent and heating means for heating the chamber to vaporize the solvent;

a direct condensation module comprising a container for condensing the vapour and collecting the solvent in the liquid phase;

20 conduit means for directing the vapour substantially without condensation from the distillation chamber to the direct condensation module, the conduit means sloping downwardly towards the distillation chamber to allow any condensate formed within the conduit to drain into the distillation chamber;

a vapour management module for condensing vapour remaining uncondensed by the direct condensation module; and

a vapour outlet located above the surface of the liquid in the direct condensation module, the vapour outlet communicating with the vapour management module to allow for passage of vapour from the direct condensation module to the vapour management module.

In a further aspect of the invention, a vapour management system comprises a container containing heat absorbing material, a vent, a vapour inlet and means for guiding vapour from the vapour inlet through the heat absorbing material to the vent. The vapour may be guided through the container by means of a conduit extending between the vapour inlet and the vent, the conduit passing through the heat absorbing material. Alternatively, the container may contain solid heat absorbing material which is permeable to vapour and condensation and through which the vapour passes from the vapour inlet to the vent.

## BRIEF DESCRIPTION OF THE DRAWINGS

Figure 1 is a schematic view of a preferred embodiment of the vapour recovery system comprising a distillation unit, a direct condensation module and a vapour management module.

Figure 2 is a sectional view of a preferred embodiment of the distillation unit of the vapour recovery system illustrated in Figure 1.

Figure 3 is a sectional view of a preferred embodiment of the distillation unit of the vapour recovery system illustrated in Figure 1, in which the heating means is located at the upper end of the distillation chamber.

5 Figure 4 is a sectional view of a preferred embodiment of a lined distillation chamber of the vapour recovery system illustrated in Figure 1.

Figure 5 is a sectional view of a preferred embodiment of the direct condensation module of the vapour recovery system illustrated in Figure 1.

10

Figure 6 is a sectional view of a preferred embodiment of the vapour management module of the vapour recovery system illustrated in Figure 1.

15

Figure 7 is a partial sectional view of an alternative embodiment of the vapour management module in which embodiment the heat absorbing material is in a solid form.

Figure 8 is a schematic representation of a heating control system that is employed in the distillation module to control the rate of vaporization of solvents.

20

#### **DETAILED DESCRIPTION OF PREFERRED EMBODIMENTS**

The preferred embodiment of a vapour recovery system for solvents according with the invention is shown in Figure 1. In this embodiment the vapour recovery system [10] comprises a distillation module [1], a direct condensation module [11] and a vapour

management module [31]. In this embodiment of the invention the solvent or mixture of solvents to be recovered is heated in the distillation module [1] to generate solvent vapour. This solvent vapour is then directed through a downwardly inclined conduit [12] to a vapour inlet [13] to the direct condensation module [11]. This downwardly inclined conduit [12] in a preferred embodiment of the invention extends within and toward the bottom of the condensation module [11]. There is substantially no condensation of the vapour in the conduit [12] but any condensate which does form runs down into the condensation module [11] and, therefore, no back-pressure is created by the condensate formation. The condensation module [11] is charged with a coolant liquid [14] which is the same solvent as that being distilled. Thus, as will be described in more detail hereinafter, in the condensation module [11], the vapour is subjected to a first round of cooling in which the heat absorbing material is the solvent to be recovered in the liquid phase [14]. Some vapour may pass through and exit from this liquid [14]. This vapour, plus air, then passes from the condensation module [11] through the vapour outlet [32] into the vapour management module [31]. In the vapour management module [31] the vapour air mixture is required to pass through a heat-absorbing material [44] and this heat exchange process leads to further condensation of vapour from the mixture. The remaining gases then leave the vapour management module [31] through a vent [42] and are substantially free of any solvent vapour. Preferably, any condensate formed in the vapour management module [31] runs back into the condensation module [11]. However the condensate formed in the vapour management module [31] can also be run into a secondary container, if desired.

In a preferred embodiment illustrated in Figure 2, the distillation module [1] comprises a distillation chamber [2] in which the contaminated solvent or solvent mixture [S] to be recovered is collected. The distillation chamber [2] is closed to prevent the escape of any vapour generated therein other than through the conduit [12]. The size of the conduit [12] and the opening of the vapour inlet [13] to the direct condensation module [11] should be adequate to allow free passage of vapour from the distillation chamber [2] without resulting in a pressure build up in the distillation chamber [2]. Further, the conduit [12] is ideally positioned toward the upper end of the distillation chamber [2] since the hot vapour will rise. This distillation chamber [2] sits within a larger heating vessel [3] containing an oil bath [5]. The heating vessel [3] is provided with one or more heating elements [4] immersed in the oil and, in operation, each heating element [4] heats the oil [5], which in turn heats the distillation chamber [2] at least until the solvent [S] within the distillation chamber reaches its boiling point and vapour is generated. Once the boiling point of the solvent is reached, the power supplied to the heating element is controlled to regulate the rate of vaporization of the solvent until the solvent is substantially all evaporated.

It is essential that the oil [5] have a boiling point higher than that of the solvent to be recovered or, in the case of a solvent mixture, the boiling point of the highest boiling component of the mixture. In addition, the oil [5] should not be flammable within the temperature ranges in which the distillation module [1] will operate. In the preferred embodiment, the oil [5] in the heating vessel [3] will surround a substantial portion of the distillation chamber [2] (for example, to the level 5a in Figure 2) to ensure that there is

sufficient heat to maintain the evaporated solvent in the vapour phase at least as far as the conduit [12].

While the preferred embodiment describes the means for heating the distillation chamber [2] as comprising a heating vessel [3] containing one or more heating elements [4] immersed in oil [5], alternative means of heating the distillation chamber [2] are possible. In one alternative embodiment, the means for heating the distillation chamber [2] is an infrared lamp [L] located toward the upper end of the distillation chamber [2] as illustrated in Figure 3. The heating provided by such a lamp can be regulated by rheostatic control of the intensity of the lamp. In this embodiment of the invention, the solvent [S] in the distillation chamber [2] is heated from the top down. This top heating provides the advantage that only the top layer of the liquid to be distilled needs to be heated to initiate distillation. Further, as the distillation progresses, it is only the energy of vaporization for the top layer of the liquid that needs to be provided to continue the distillation.

The distillation chamber [2] is preferably provided with an anti-vacuum valve [V] (Figure 2) which prevents vapour from escaping from the distillation chamber [2], but is triggered to allow entry of outside air when the pressure within the distillation chamber [2] falls below atmospheric. As the distillation chamber [2] cools down following distillation, the pressure in the distillation chamber [2] falls. Since the conduit [12] provides a passage from the distillation chamber [2] to the vapour inlet [13] which communicates with the liquid condensed in the condensation module [11], without the anti-vacuum valve [V] in the distillation chamber [2], the reduction in pressure would lead to a back-flow situation

with condensed solvent being drawn from the condensation module [11] into the conduit [12] through the vapour inlet [13], and thence into the distillation chamber [2].

In an alternative embodiment of the distillation module [1] there is a line feeding contaminated solvent directly into the distillation module [1] through source inlet [7]. In this embodiment, a means for preventing flow-back from the condensation module [11] to the distillation chamber [2] is provided. In addition, the anti-vacuum valve can be shut off such that any negative pressure created in the distillation chamber [2] as it cools can be used to draw more contaminated solvent for recycling into the distillation chamber [2] through source inlet [7]. This acts as a natural pump which can be used as part of the process since it allows continuous flow, without the need for separate pumps.

One aspect of the current invention is a heating control system, as illustrated schematically in Figure 8, that is employed in the distillation module to control the rate of vaporization of the solvent or solvents. In the distillation module, the solvents are separated from the impurities in the solution and may also be separated from each other. The control system is designed to do this in a time efficient manner while also minimizing operator intervention.

The heating control system has three key components, a variable heating means [61], for example, a plurality of the heating elements [4] of Figure 2, a temperature sensing means [62], for example, a temperature probe [6] (see Figure 2) which may be either a platinum thermistor or a thermocouple, and a control computer [63], for example, a

microprocessor with required software. The control computer [63], by use of a control law, selectively triggers relays [64] which are in series between a power supply and heating means [61] and which energize the heating means [61] in an ordered manner, in response to temperature reference signals input to the control computer [63] from the temperature sensing means [62]. In a preferred embodiment, which is especially useful where a mixture of solvents is to be distilled, an important element of this control system is a control law that allows the system to operate in 2 modes. The first mode is a solvent mode where the system begins to heat the mixture of solvents until the boiling point of the solvent with the lowest boiling point is reached. At the temperature of that lowest boiling point the power delivered to the heating means is maintained at a constant level to provide the energy of vaporization at a desired rate, until the first solvent has been substantially distilled from the solution. Once the first solvent has substantially distilled, the power provided to the system is no longer used to provide the required energy of vaporization and no further heat is being lost as a result of heated vapor, and therefore the temperature of the liquid in the distillation chamber [2] begins to rise. The power provided to the heating means can again be increased until the boiling point of the next solvent is reached. This control cycle is repeated until the solvents have all been vaporized.

The second mode is the water mode. In the water mode of the control system there is no advantage to stepped regulation of the temperature. Water has a relatively high specific heat capacity and requires significant energy input in order to boil. Therefore, in the water mode, it is not necessary to regulate the temperature as closely. In other words, in the water mode the distillation chamber and its contents can be heated continuously until the

evaporation is complete, at which time a timed heating cycle can then be brought into effect. The two modes of the control system allow the distillation chamber to be used for vaporization of water and organic solvents. Distillation can take place with a mixture of water and organic solvents, or either alone, with no significant foaming.

5

The power applied to the heating means [61] during the vaporization phase for any particular solvent provides the energy of vaporization for that solvent. Therefore, controlling the power applied to the heating means [61] also controls the rate of vaporization, and is used to maintain an equilibrium with the condensation rate of the vapour in the system.

10

In the embodiment shown in Figure 2, the temperature sensing means is a probe [6] that is used to monitor the temperature of the distillation chamber [2]. The probe [6] detects an increase in temperature of the distillation chamber [2] as the solvent is heated. The rate of evaporation of solvent from the distillation chamber [2] is regulated by means of the control system of Figure 8.

15

Controlling the rate of vaporization of the solvent in the distillation chamber [2] means that the vapour pressure in the distillation chamber [2] is closely regulated. Since the pressure differential between the distillation module [1] and the condensation module [11] is important, this strict regulation of vapour pressure will enhance the efficiency of vapour recovery. In addition, by closely regulating the rate of vaporization of the solvent,

20

it is possible to reduce the required mass for solvent condensation in the condensation module [11].

After the liquid in the distillation chamber [2] has evaporated, a timed heating cycle is brought into effect by means of a timer system (not shown) which maintains the temperature in the distillation chamber [2] for a predetermined period of time. This post-evaporation heating ensures that essentially all of the solvent to be recovered is distilled. Further, the continued heating drives off any residual solvents and bakes any contaminants in the distillation chamber [2] so that the resulting solids can be disposed of more conveniently at a lower cost and with reduced environmental problems as compared to unbaked contaminants. In the embodiment of the invention as illustrated in Figure 4, the distillation chamber [2] is lined with a bag [8] such that, following baking, the entire bag [8] containing the baked contaminants can be disposed of. The bag [8] is stable within the temperature range of the distillation chamber [2]. In addition, it is important that the bag [8] be inert with respect to the solvents to be distilled. It is clear that the bag [8] can be made of any material provided it is heat stable, does not react with the solvents to be distilled, and is non-permeable, such as Teflon (trade-mark for polytetrafluoroethylene).

As can more clearly be seen by reference to the preferred embodiment illustrated in Figure 5, the condensation module [11] is comprised of a container [20] into which the vapour to be recovered enters via vapour inlet [13]. The condensation module is primed using a predetermined volume of the solvent to be recovered in the liquid phase [14]. This liquid [14] is free from contamination. The vapour entering the condensation module [11]

is directed by the inlet [13] to pass beneath the surface [15] of the liquid [14] such that the vapour bubbles through the liquid.

Ideally, the vapour entering the condensation module [11] is forced to the bottom of the container [20] by the inlet [13]. Some of the vapour will be cooled by the liquid [14] such that it condenses and combines with the liquid. As a result of such condensation the level of liquid in the container [20] will rise. The condensation may lead to an increase in the temperature of the liquid [14] if there is no external source for cooling the liquid.

However, the corollary increase in the volume of liquid [14] in the container [20] means that the vapour which subsequently enters the container [20] must travel a greater distance through the liquid [14]. In addition, the coolest liquid will fall to the bottom of the container [20] where the vapour to be condensed is entering the condensation module [11].

Some vapour may pass through the liquid [14] and accumulate above the surface [15] in the upper volume [21] of the container [20]. The only way this accumulated vapour can escape from the container [20] is by passing through a vapour outlet [32] positioned above the upper volume [21]. The vapour, having entered the vapour outlet [32] from the condensation module [11], then passes from the outlet [32] into the vapour management module [31].

In a preferred embodiment of the invention, as illustrated by Figure 6, the vapour management module [31] comprises a sealed chamber [45] containing a serpentine tube [43] communicating with the vapour outlet [32] at its entrance end and a vent [42] at its

exit end. The mixture of air and solvent vapour exiting the condensation module [11] is directed via the outlet [32] through the tube [43], which is surrounded by a cooling medium [44] inside the sealed chamber [45]. The cooling medium [44] absorbs heat and therefore causes further condensation of the vapour so that substantially all of the vapour escaping from the condensation module [11] is condensed and prevented from reaching the atmosphere through vent [42]. The medium [44] can be any suitable coolant medium. Ideally, the medium [44] will provide sufficient heat absorption for condensation of all vapours, such that only air exits the system through vent [42].

In one preferred embodiment of the invention, the medium [44] is water mixed with a salt to form a crystallized mass which has a low expansion rate and can be contained safely in the sealed chamber [45]. The tube [43] allows condensed solvent to flow back by gravity through the outlet [32] into the condensation module [11], while allowing the remaining uncondensed vapour (which is a very small amount, if any) and air to exit the vapour management module [31] to the atmosphere through the vent [42]. The condensate can continue to flow counter to the air/vapour flow, through the outlet [32] and be collected in the container [20] of the condensation module [11], or in a separate container.

The container [20] may be provided with a tap [T], which can be used to drain the liquid [14]. Ideally, this tap is situated below the surface [15] of the liquid, and the closer to the base of the container [20], the more liquid [14] can easily be drained off. The advantage of this arrangement is that liquid [14] being collected can be accessed at any time

without losing vapour from the system. Further, condensed liquid [14] can be removed from the container [20] without interruption of the condensation.

If desired, a downwardly sloping overflow pipe [D] may be provided in the container [20] at a predetermined overflow level. As the level [15] of liquid [14] rises to that overflow level, a fixed volume of liquid is maintained in the container [20]. Any liquid [14] in excess of that volume enters the overflow pipe and runs by gravity into a collection vessel. This provides an advantage in that a large volume of material can be used as the coolant.

In another embodiment of the vapour management module [31], as illustrated in Figure 7, the air/solvent vapour mixture is allowed to pass from the outlet [32] to the vent [42] without the use of a tube [43]. In this embodiment, the material [44] is a solid material for example, ball bearings or glass chips, through which the vapour and condensate are able to pass. The material may be prevented from falling back through the outlet [32] into the container [20] either by selecting the size of the material particles to be sufficiently large, or by the insertion of a support member [46] which is permeable to both the liquid [14] and the air/vapour mixture, but through which the material [44] cannot pass.

Maximizing the ratio of the heat exchange surface to the volume of vapour passing into the vapour management module [31] increases the efficiency of the condensation in the vapour management module [31].

In accordance with the present invention, the vapour management module [31] can be designed such that essentially no vapour exits the vent [42]. This is achieved by ensuring that the rate of heat input does not exceed the rate of heat absorption in the vapour management module. It is clear that factors such as the rate of vapour flow, the vapour temperature, the heat absorption properties of the material and the path length through the vapour management module are important. In one embodiment of the invention, the heat absorbing material is a crystalline salt, the pipe [43] is of 12mm bore and 75 cm in length, made of heat conductive metal such as copper, and the heat input to the vapour management module in the form of vapour is 1500W.

10

In selecting the appropriate solid material [44] in the above embodiments, ideally the material should allow the vapour to flow through at approximately atmospheric pressure, provide the required absorption of heat, and allow the condensed liquid [14] to flow by gravity back to a reservoir.

15

Those skilled in the art will appreciate that various combinations of condensation modules [11] and vapour management modules [31] are possible. Further, it is possible to use either the condensation module or the vapour management module in isolation from the system, provided there is an input of vapour to such modules. It is possible to use the vapour management module [31] to recover vapour from any vent or exhaust. Examples of situations where the vapour management module [31] could be used are on a vent to an oil storage tank, a vent on a gasometer, or a vapour stack of a spray booth. In these situations, the vapour would arise as a consequence of evaporation of the liquid to be recovered.

20

Condensate formed in such vapour management modules can then run back by gravity into the vent and ultimately back to the container of the liquid to be recovered, or to another container. It is clear to those skilled in the art that in these situations the heat absorbing material must be cooler than the vapour to be recovered.

5

Further, while the preferred embodiment utilizes both a condensation module [11] and a vapour management module [31] and has been found to have excellent results, each solvent to be recovered will have different requirements. It is certainly possible to subject the vapour to sequential steps of direct condensation and/or to sequential vapour management modules [31]. The efficiency of vapour recovery will determine the most suitable module arrangement.

10

It should be clear that while the preferred embodiments described above describe specific arrangements of heat absorbing material, variations are possible. For example, it is not essential to have any liquid in the condensation module [11] prior to initiation of condensation. Alternatively, any material that absorbs heat from the vapour but does not chemically react with it would be suitable to use within the condensation module, including a solid mass or air. A solid inert mass such as rocks or ball bearings are suitable to absorb heat in the condensation module [11]. Alternatively, air in the condensation module [11] can rapidly absorb heat from the vapour entering the condensation module [11] since heat exchange is rapid between gases. Any liquid [14] accumulating as a result of condensation in the condensation module [11] also acts to absorb heat from the vapour.

15

20

While only specific embodiments of the invention have been described, it is apparent that various additions and modifications can be made thereto, and various alternatives can be selected. It is, therefore, the intention in the appended claims to cover all such additions, modifications and alternatives as may fall within the true scope of the invention.

5

10

## CLAIMS

THE EMBODIMENTS OF THE INVENTION IN WHICH AN EXCLUSIVE PROPERTY OR PRIVILEGE ARE CLAIMED ARE DEFINED AS FOLLOWS:

1. A solvent vapour recovery system comprising:

5 a distillation module comprising a distillation chamber for said solvent and heating means for heating said chamber to vaporize the solvent;

a direct condensation module comprising a container for condensing the vapour and collecting the solvent in the liquid phase;

10 conduit means for directing the vapour substantially without condensation from said distillation chamber to the direct condensation module, said conduit means sloping downwardly towards said distillation chamber to allow any condensate formed within said conduit to drain into said distillation chamber;

a vapour management module for condensing vapour remaining uncondensed by said direct condensation module; and

15 a vapour outlet located above the surface of said liquid in said direct condensation module, said vapour outlet communicating with said vapour management module to allow for passage of vapour from the direct condensation module to the vapour management module.

2. The apparatus of claim 1 wherein the container holds a heat absorbing material through which said vapour is passed.
3. The apparatus of claim 2 wherein the heat absorbing material comprises the vapour to be recovered in its liquid phase.
- 5 4. The apparatus of claim 2 wherein the heat absorbing material is air.
5. The apparatus of claim 2 wherein the heat absorbing material is an inert solid mass.
6. The apparatus of claim 2 wherein the heat absorbing material comprises a combination of the vapour to be recovered in its liquid phase and an inert solid mass.
7. The apparatus of claim 3 or 6 wherein the conduit directs vapour beneath the surface  
10 of said liquid.
8. The apparatus of any one of claims 1 - 7 wherein the conduit directs vapour to the bottom of said container.
9. The apparatus of claim 3, 6 or 7 wherein the vapour outlet is above the surface of said liquid.
- 15 10. The apparatus of any one of claims 1 - 9 wherein the distillation chamber is located within an oil bath which is heated by said heating means.
11. The apparatus of claim 10 wherein the heating means comprises one or more heating elements located within said oil bath.

12. The apparatus of any one of claims 1 - 9 wherein the distillation chamber is heated by means of an infrared heater located within said chamber.

13. The apparatus of any one of claims 1 - 12 further comprising means for connecting said heating means to a power supply and a control means for controlling the power  
5 provided by said power supply to said heating means, said control means comprising a computer, temperature sensing means for sensing the temperature of said distillation chamber and generating temperature reference signals which are provided as input signals to said computer and switching means for selectively providing power to said heating  
10 means from said power supply, said computer being programmed to apply control signals to said switching means to control the amount of power applied to said heating means in accordance with said input signals received from said temperature sensing means.

14. The apparatus of claim 13, wherein said computer is programmed with a set of parameters based on the input signals received from the temperature sensing means which, if exceeded, will activate said switching means to perform an ordered shutdown of said  
15 heating means by selectively activating said switching means to disconnect said heating means from said power supply.

15. The apparatus of claim 13, wherein the temperature sensing means comprises one or more platinum thermistor temperature probes.

16. The apparatus of claim 13, wherein said heating means consists of at least one  
20 heating element.

17. The apparatus of claim 13, wherein said heating means consists of a direct heating means.

18. The apparatus of claim 17, wherein said heating means consists of an infrared heating lamp.

5 19. The apparatus of claim 13, wherein said switching means comprises one or more relays.

20. The apparatus of claim 13, wherein said heating means consists of a plurality of heating elements and said switching means comprises a plurality of relays respectively connecting said heating elements to said power supply.

10 21. The apparatus of claim 13, wherein said computer is programmed with a control law so that when a mixture of solvents including an aqueous component is to be distilled in said distillation chamber, said computer runs a distillation procedure wherein the heating means raises the solution to a temperature causing the solvent with the lowest boiling point to vaporize, the temperature is then maintained until the aforementioned solvent is  
15 substantially removed from the solution, at which time the temperature is raised again until the solvent with the next lowest boiling point begins to vaporize and the process is then repeated until all solvents have been distilled off.

22. The apparatus of claim 13, wherein computer controls said switching means to vary the input to the heating means to balance the rate of vaporization of a solvent with the rate  
20 of condensation of the same solvent in a separate, but connected, container.

23. The apparatus of claim 1, wherein said vapour management module comprises a container containing heat absorbing material and a conduit extending between said vapour outlet of said direct condensation module and a vent, said conduit passing through said heat absorbing material.
- 5 24. The apparatus of claim 23, wherein said vent is at a higher elevation than said vapour outlet of said direct condensation module.
25. The apparatus of claim 23 or 24 wherein the heat absorbing material is a liquid.
26. The apparatus of claim 23 or 24 wherein the heat absorbing material is crystalline.
27. The apparatus of claim 23 or 24 wherein the heat absorbing material is water mixed  
10 with a salt to form a crystallized state.
28. The apparatus of claim 1, wherein said vapour management module comprises a container containing solid heat absorbing material which is permeable to vapour and condensation through which said vapour passes from said direct condensation module to said vent.
- 15 29. The apparatus of claim 28 wherein the heat absorbing material is steel ball bearings.
30. The apparatus of claim 28 wherein the heat absorbing material is glass chips.

31. The apparatus of any one of claims 28 - 30 wherein a support member is provided in said vapour outlet of said direct condensation module, said support member being permeable to vapour and condensation and impermeable to said heat absorbing material.

32. The apparatus of any one of claims 1 - 31 wherein the container of said direct condensation module is provided with a drainage means for draining liquid therefrom.

33. The apparatus of claim 32 wherein the drainage means comprises a tap.

34. The apparatus of claim 32 wherein the drainage means comprises an overflow pipe in said container.

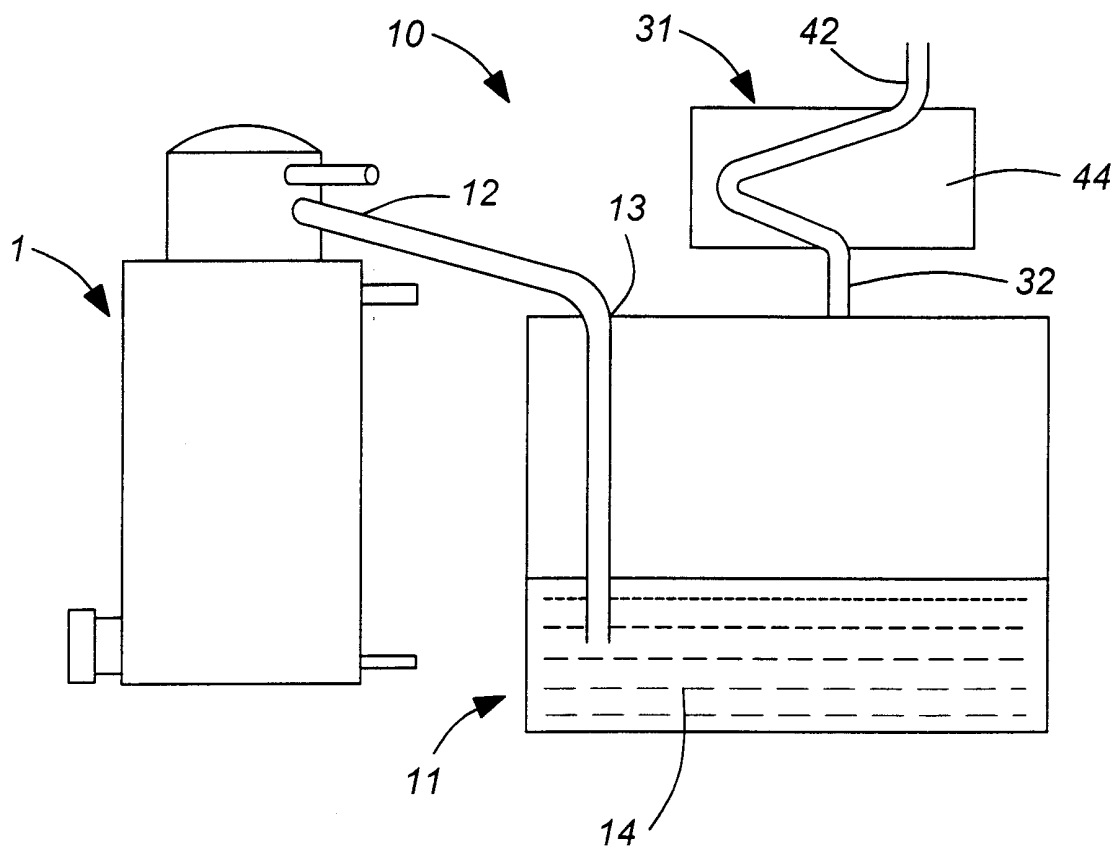
35. A vapour management system comprising a container containing heat absorbing material, a vent, a vapour inlet and means for guiding vapour from said vapour inlet through said heat absorbing material to said vent.

36. The apparatus of claim 1, wherein said vapour management module comprises a container containing heat absorbing material and a conduit extending between said vapour inlet and said vent, said conduit passing through said heat absorbing material.

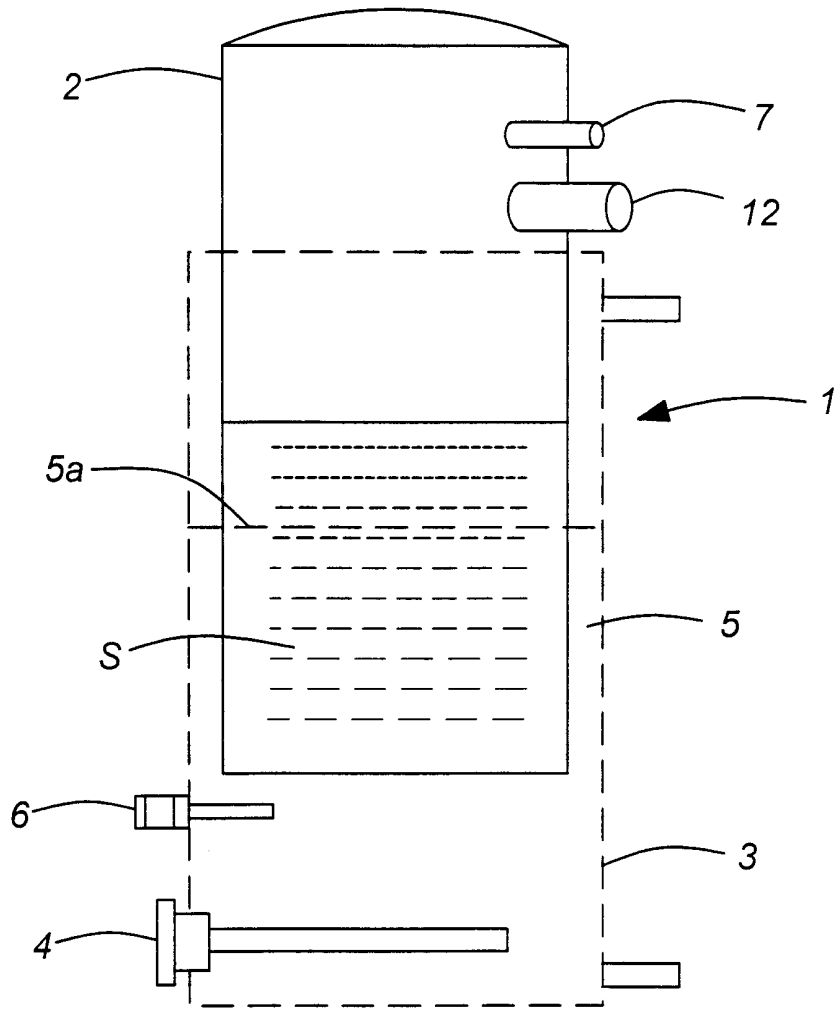
37. The apparatus of claim 35, wherein said vapour management module comprises a container containing solid heat absorbing material which is permeable to vapour and condensation through which said vapour passes from said vapour inlet to said vent.

38. The apparatus of claim 37 wherein the heat absorbing material is steel ball bearings.

39. The apparatus of claim 37 wherein the heat absorbing material is glass chips.
40. The apparatus of any one of claims 37 - 39 wherein a support member is provided in said vapour inlet, said support member being permeable to vapour and condensation and impermeable to said heat absorbing material.

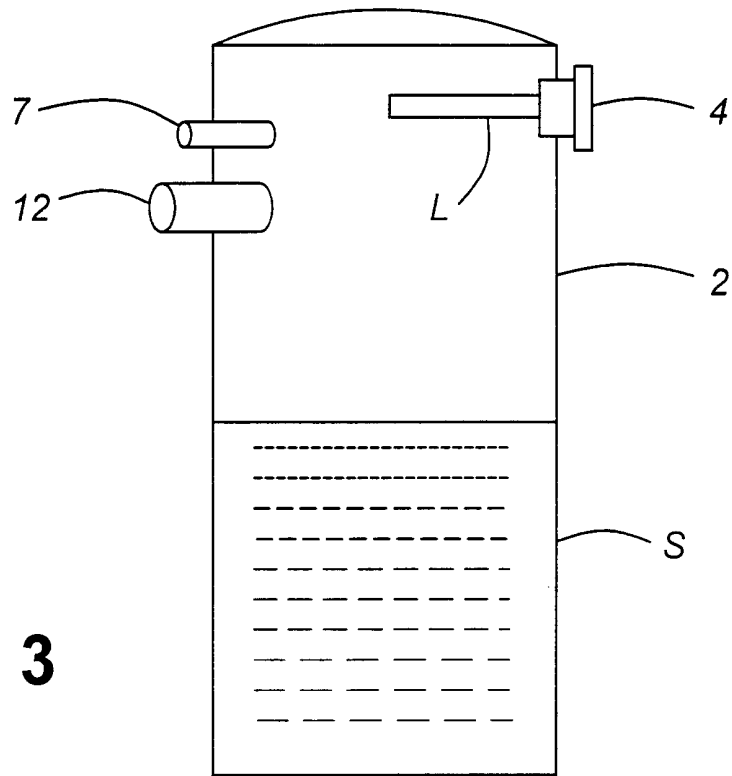


**FIG. 1**

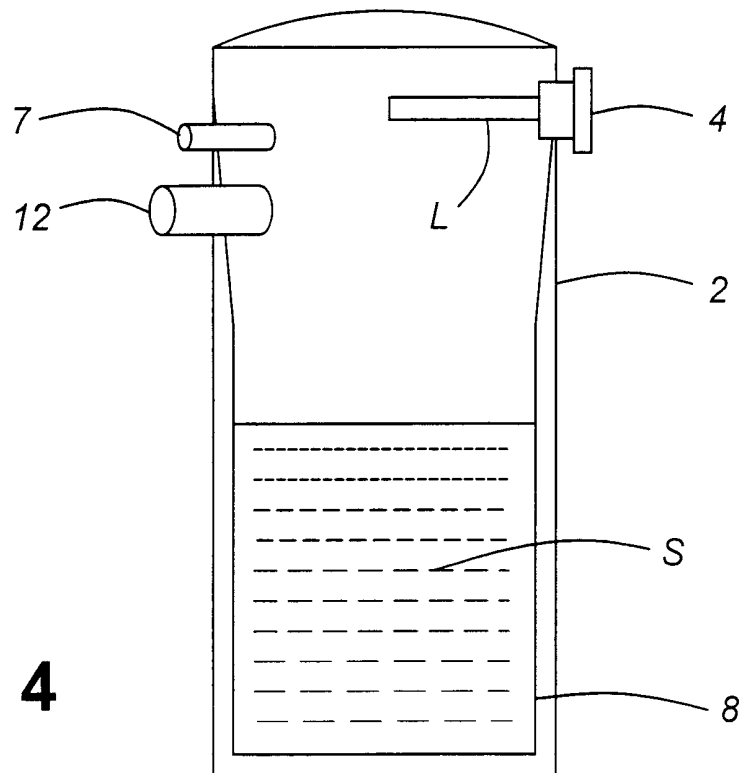


**FIG. 2**

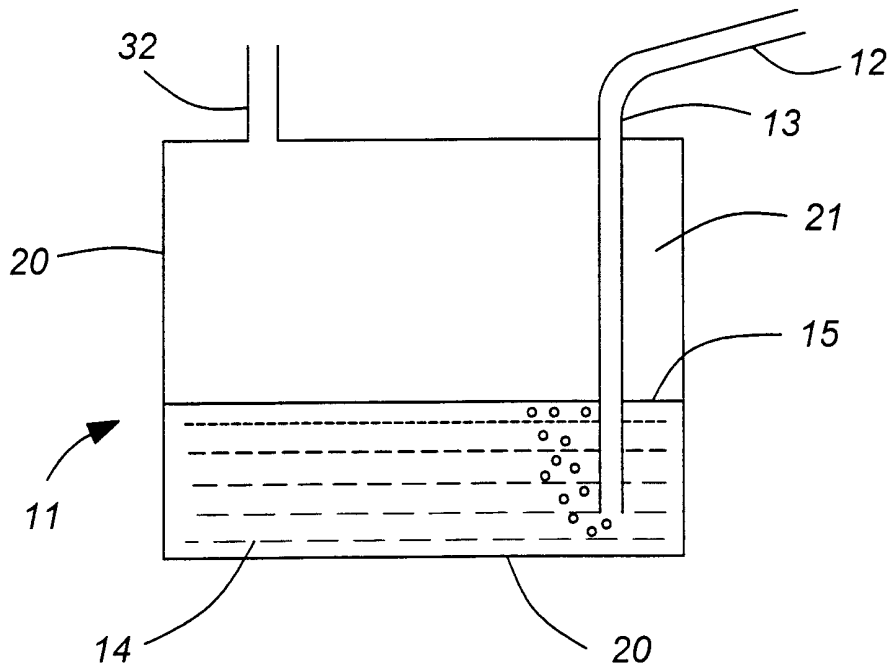
3/6



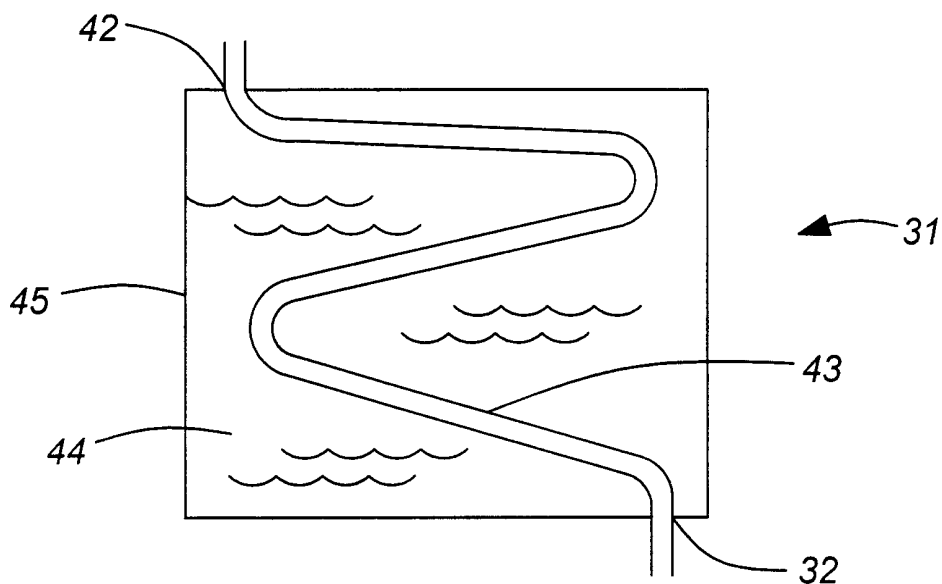
**FIG. 3**



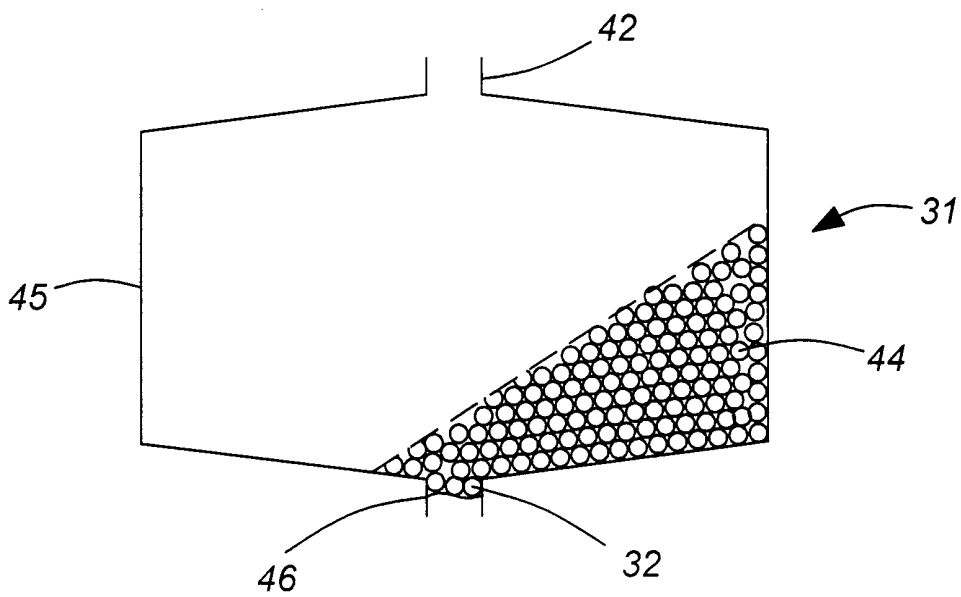
**FIG. 4**



**FIG. 5**



**FIG. 6**



**FIG. 7**

6/6

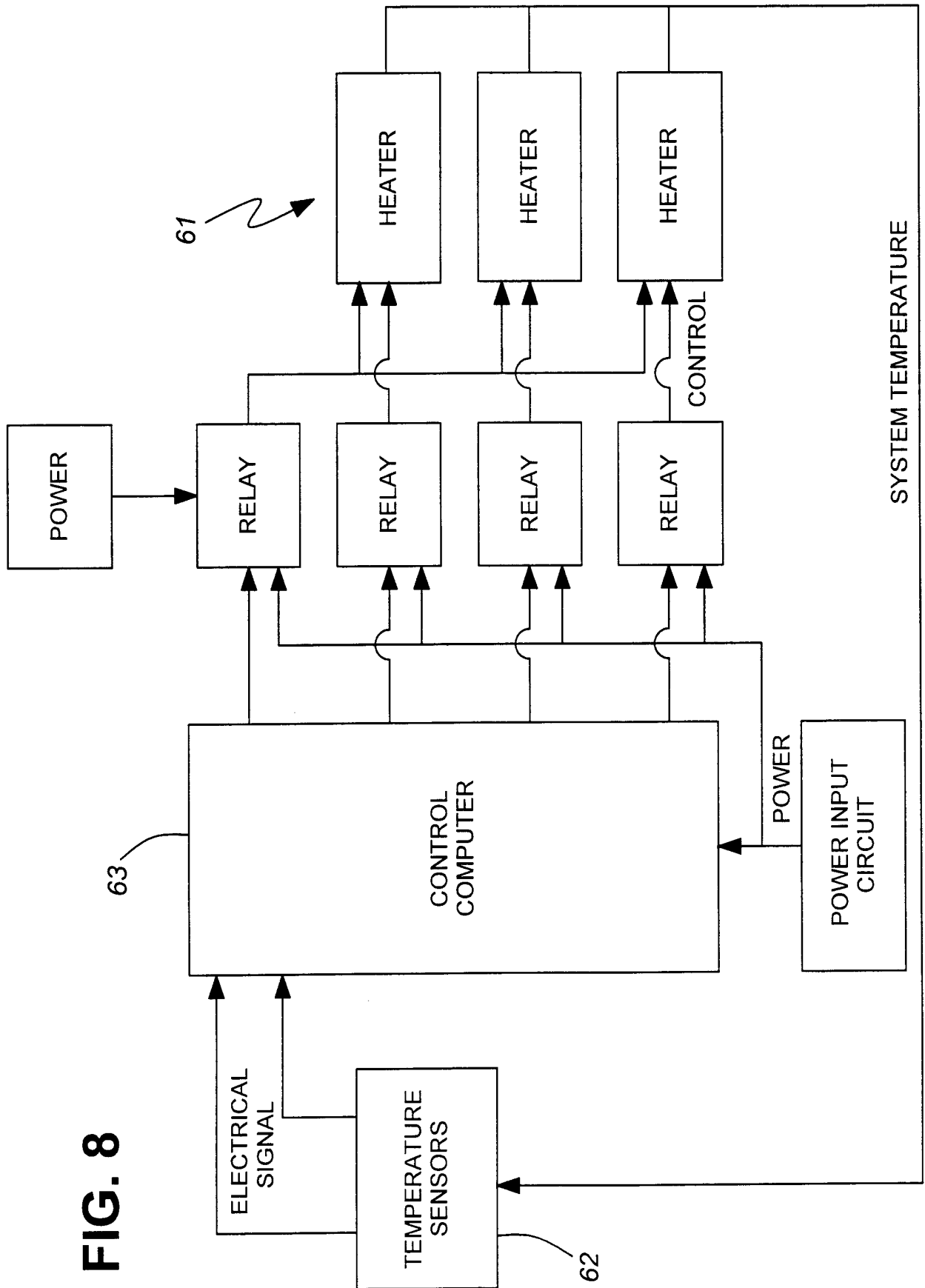


FIG. 8