

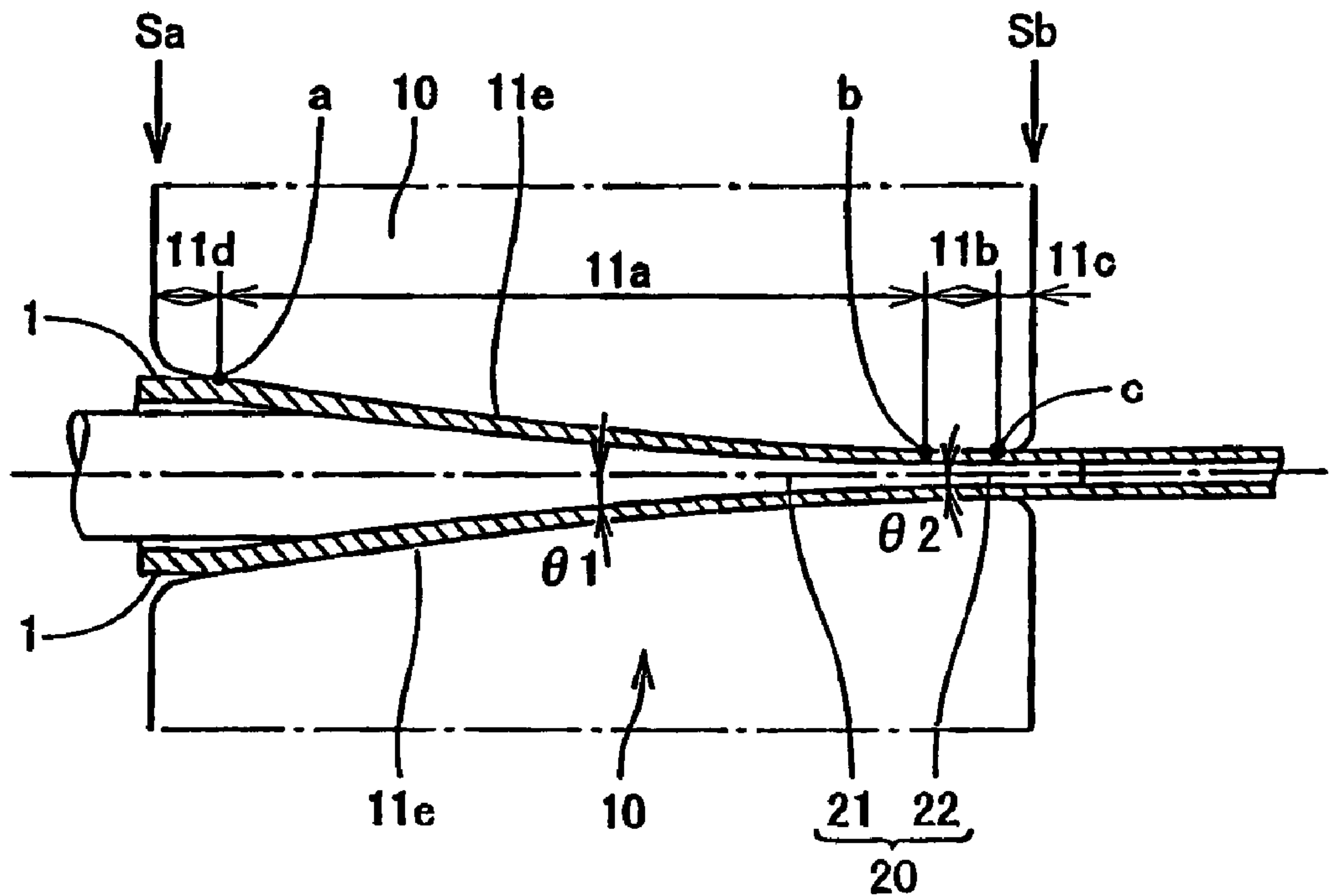

(22) Date de dépôt/Filing Date: 2006/06/27  
 (41) Mise à la disp. pub./Open to Public Insp.: 2006/12/28  
 (45) Date de délivrance/Issue Date: 2009/01/13  
 (30) Priorité/Priority: 2005/06/28 (JP2005-188649)

(51) Cl.Int./Int.Cl. *B21B 17/04* (2006.01),  
*B21B 21/02* (2006.01), *B21B 25/00* (2006.01)  
 (72) Inventeurs/Inventors:  
TSUYUGUCHI, SATOSHI, JP;  
ONO, TOSHIHIDE, JP  
 (73) Propriétaire/Owner:  
SUMITOMO METAL INDUSTRIES, LTD., JP  
 (74) Agent: GOWLING LAFLEUR HENDERSON LLP

(54) Titre : PROCÉDE DE LAMINAGE A FROID POUR TUBES METALLIQUES  
 (54) Title: COLD ROLLING PROCESS FOR METAL TUBES



(57) Abrégé/Abstract:

In the cold rolling process by pilger rolling that holds a mandrel between each of paired roll-dies, by optimizing the side relief rate SR and the mandrel factors like the taper  $\theta 1$  in the primary deformation zone of the mandrel and the taper  $\theta 2$  in the final size reduction zone thereof, and the feed rate F of the workpiece material, and at the same time by properly adjusting the relationship between the side relief rate SR and the feed rate F, the dimension-related shape characteristics (near-perfect round shape) of the tube inside surface after the final finishing rolling process by pilger rolling can be ascertained to thereby ensure excellent surface property without requiring a new apparatus, and further without causing the decrease of the product yield and/or the increase of the manufacturing costs. Thus, this can be widely applied for producing steam generator tubes which exhibits high S/N ratio in the inner coil eddy current testing.

## ABSTRACT

In the cold rolling process by pilger rolling that holds a mandrel between each of paired roll-dies, by optimizing the side relief rate SR and the mandrel factors like the taper  $\theta_1$  in the primary deformation zone of the mandrel and the taper  $\theta_2$  in the final size reduction zone thereof, and the feed rate F of the workpiece material, and at the same time by properly adjusting the relationship between the side relief rate SR and the feed rate F, the dimension-related shape characteristics (near-perfect round shape) of the tube inside surface after the final finishing rolling process by pilger rolling can be ascertained to thereby ensure excellent surface property without requiring a new apparatus, and further without causing the decrease of the product yield and/or the increase of the manufacturing costs. Thus, this can be widely applied for producing steam generator tubes which exhibits high S/N ratio in the inner coil eddy current testing.

## COLD ROLLING PROCESS FOR METAL TUBES

### FIELD OF THE INVENTION

The present invention relates to a cold rolling process for metal tubes by pilger rolling, and more particularly, to a cold rolling process for metal tubes which have excellent dimensional accuracy after the final finishing stage as final sizing in pilger rolling, especially dimension-related shape characteristics (roundness) and surface property for the tube inside surface, thereby enabling to obtain a sufficiently high S/N ratio (signal to noise ratio) in conducting an inner coil eddy current testing.

### DESCRIPTION OF THE RELATED ART

Usually, as a cold working process for metal tubes, a cold drawing process by a draw bench and a cold rolling process by a pilger mill are customarily applied. In particular, since a cold rolling process by a pilger mill has a feature such that tube materials can be cold worked with a high reduction rate in comparison with a cold drawing process, the cold rolling process by the pilger mill (pilger rolling) is generally applied in manufacturing metal tubes, using the tube materials with high-strength and less workability.

Fig. 1 is a diagram explaining the overall configuration of a pair of roll-dies to be used in pilger rolling. In the pilger rolling, there is provided a pair of roll-dies, an upper and lower roll-dies, each of which is provided with a roll caliber on its circumferential surface, whereas a mandrel with a taper such that the diameter thereof becomes smaller as nearing toward the front end is set between each of the above roll-dies. Each of roll-dies 10 is configured to have the roll caliber 11 on its circumferential surface and to be supported at a roll stand 12 by means of a roll shaft mounted at the center axis of the rolls. At one end of the roll shaft, a pinion gear 13 with the similar rotating diameter to that of roll-dies 10 is drivenly secured to a horizontally arranged rack gear 14.

The roll-dies 10 reciprocally rotate in the direction of the arrow B in cooperation with the reciprocating movement of the rack gear 14 in the direction of the arrow A via the pinion gear 13. Hence, the roll calibers 11 provided on the circumferential surface of the roll-dies 10 are to work and reduce the tube materials as work piece materials in association with the reciprocally rotating movement of the roll-dies 10.

Fig. 2 is a diagram showing a developed view of the roll caliber of roll-die in order to explain how the tube material is rolled in pilger rolling. In this diagram, there is described a schematic representation that, where the roll caliber bottom 11e of the roll-dies 10 subjects the tube material 1 to be worked and reduced, the whole path length from the head end dead center Sa to the bottom end dead center Sb is developed.

The roll caliber 11 provided on the circumferential surface of the roll-die 10 is configured to have an approximate oval shape of cross-section profile whose major axis is arranged to align in the width-wise direction, comprising a primary deformation zone 11a in which the cross-sectional radius of the roll caliber continuously becomes smaller from the deformation starting position "a" down to the deformation ending position "b" and a final size reduction zone 11b in which the cross-sectional radius stays same in the range from the above deformation ending position "b" on end down to the final sizing ending portion "c", wherein a top relief 11d on the side of the head end dead center Sa in the primary deformation zone 11a and a bottom relief 11c on the side of the bottom end dead center Sb in the final size reduction zone 11b are provided respectively.

Between each of the paired roll-dies 10, a mandrel 20 having a primary deformation zone 21 and a final size reduction zone 22 such that its diameter becomes smaller as nearing the front end is provided, whereas the primary deformation zone 21 is made to have a taper  $\theta_1$ , and whereas the final size reduction zone 22 is made to have a taper  $\theta_2$ . The mandrel 20 is aligned so that its primary deformation zone 21 and final size reduction zone 22 are disposed so as

to coincide with the primary deformation zone 11a and final size reduction zone 11b of the roll caliber 11 respectively during the rolling stroke.

Meanwhile, the tube material 1 as a workpiece material is given a predetermined feed rate while the roll-dies 10 reciprocally rotate (per one pass), and at the same time is given a turn of a predetermined angle, whereby the tube radius reducing and wall thinning in succession undergo. Namely, between the primary deformation zone 11a in the roll caliber 11 of roll-dies 10 and the primary deformation zone 21 of the mandrel 20, the tube radius reducing and wall thinning are provided, followed by the finishing work between the final size reduction zone 11b of the roll caliber 11 and the final size reduction zone 22 of the mandrel 20. Accordingly, the tube material 1 thus cold rolled is elongated corresponding to the plastic elongation rate by rolling and the feed rate for rolling, thus enabling to finally roll and finish to the aimed product dimension.

Because the cold rolling process by pilger rolling attributes to the rolling mechanism shown in the foregoing Figs. 1 and 2, it becomes possible to apply a high reduction rate to the workpiece materials to thereby allow a higher reduction rate in cold working process in comparison with the cold drawing process as afore-mentioned. Usually, in the cold rolling process by pilger rolling, to apply a high reduction rate while not compromising the productivity, a relatively high feed rate  $F$ —i.e. about 4mm per one pass—for the tube material and a cross-section area reduction rate in the range of 70 to 90% are adopted.

Fig. 3 is a diagram showing a model of roll to be utilized in designing the caliber profile of the roll-die. In this diagram, there is described the roll caliber bottom 11e of the roll-die 10 subjecting the tube material 1 to be worked and reduced, whereas the tube inside surface is supported by the mandrel 20. In designing the roll caliber, as parameters contributing to the dimensional accuracy after the final finishing stage as final sizing in pilger rolling, a roll caliber diameter  $D_x$  and a side relief amount  $F_x$  in Fig. 3 are controlled.

In the cold rolling process by pilger rolling, the roll caliber diameter  $D_x$  is

determined according to a pass schedule, while the side relief amount  $F_x$  is designed so that, to prevent the fin-like projection, the so-called overfill, on the tube outside surface from occurring, the ratio thereof is set to about 2%. Besides, the basic taper of the mandrel to be used, namely either the taper  $\theta_1$  in the primary deformation zone or the taper  $\theta_2$  in the final size reduction zone is set to 0.3 degree, and the boundary between the primary deformation zone and the final size reduction zone is deemed as the deformation ending position.

In the mean time, it has become to be required that, in the cold rolling process by pilger rolling, the dimension-related shape characteristics and/or surface property is adjusted to be best suited for the usage of the finished metal tubes. In this regard, there has been proposed to improve the dimensional accuracy etc. by utilizing various apparatus for the metal tubes to be made by the cold rolling process.

For instance, in Japanese Utility Model Publication No. 06-19902, there is proposed a cold pilger mill that includes an adjusting-and-reforming die arranged next to the in-process tube guides disposed onto a roll-die. The adjusting-and-reforming die is configured to automatically correct the in-process tube path of travel if there should slightly occur an off-set from the pass-line since it is designed to move in the direction perpendicular to the pass-line, and moreover is configured to turn, so that it can turn together with the in-process tube, thereby making it possible for the in-process tube to turn without hindrance. Accordingly, it is taught that, by combining the proposed adjusting-and-reforming die with the rolling process by the conventional cold pilger mill, a satisfactory dimensional accuracy equivalent to the case of the cold drawing process can be achieved without applying the cold drawing process.

Further, in Japanese Patent Application Publication No. 2001-105009, there is proposed a cold rolling process which employs rolling rolls preheated to the steady-state temperature during cold rolling by means of a low frequency induction heater. Namely, the above process is that in order to control the

temperature of rolling rolls to be constantly in the steady-state during cold rolling, the temperature drop due to unforced cooling during the interval between the in-line assembling and the start of rolling is anticipated, and the rolls are heated at an off-line shop in advance to the temperatures higher than that in the steady-state, whereby the dimensional variation of dies becomes least and the dimensional variation of the rolled tubes is minimized, thus enabling to yield tubes having excellent dimensional accuracy.

However, the cold pilger mill or the cold rolling process proposed in the Japanese Utility Model Publication No. 06-19902 and Patent Application Publication No. 2001-105009 entails the new apparatus such as the adjusting-and-reforming die or the induction heater. Therefore, although employing these for the cold rolling by pilger rolling can ensure the required dimensional accuracy, it becomes necessary to newly modify/renovate the mill, thus resulting in the increase of the manufacturing costs of metal tubes thus cold rolled.

#### SUMMARY OF THE INVENTION

As for metal tubes to which a cold rolling process is applied as the final finishing rolling process, the steam generator tubes (SG tubes) can be exemplified. The finished diameter of the steam generator tubes is as small as 23 mm or less, so that although the cold drawing process by the draw bench can be applied as the finishing process, the problem arises such that the work defective like the slip and/or stick likely occurs during the drawing step, thus resulting in the decrease of the production yield. In this regard, it becomes necessary that the steam generator tubes are efficiently produced by the final cold rolling process by pilger rolling.

Fig. 4 is a diagram showing the model configuration of an inner coil eddy current testing apparatus to be applied for the periodic in-service inspection of steam generator tubes in Nuclear Power Plant. The eddy current testing

apparatus 2 (comprising a probe 2a and coil 2b) shown in Fig. 4 travels the inside of the tubes to periodically check whether the flaw(s) is present on the inside surface of the tubes. Then when the surface property on the tube inside surface is in poor conditions during eddy current testing, for instance, when the concave/convex irregularities are formed on the tube inside surface, these should cause the noise signals to thereby hide the genuine flaw signals, thus likely increasing the risk to fail detecting harmful defects.

In this regard, when the inner coil eddy current testing is conducted under conditions that the S/N ratio is high, namely, the noise signals are low, the genuine flaw signals can be assuredly recognized, thus enabling to avoid failing to detect harmful defects. As a rough standard, it can be perceived that, as shown in the foregoing Fig. 4, in case the reference tube 3 be made to have a through-wall drill hole 3a of 0.66 mm in diameter which should constitute the artificial defect signal, it becomes necessary to ensure the S/N ratio to be 15 or more.

With regard to the generation of noise signals in the inner coil eddy current testing for metal tubes subjected to the cold rolling process by pilger rolling, the present inventor et al made an in-depth survey and investigations to end up in finding that a first and second aspects attribute to the dimensional variations in length-wise direction of the tubes, thereby causing the noise signals.

A first aspect is that, as recited with reference to the apparatus configuration shown in the foregoing Figs. 1 and 2, the tube materials as workpiece materials are rolled shortly after changing the phase angle by making a predetermined turn in the circumferential direction in association with the roll-dies movement, and thus, the cross-section profile of the tube inside commonly becomes oval and the oval appearance in phase-wise trajectory moves spirally over the entire length of the tube. The way things are, because the cross-section profile of the tube inside surface becomes oval, the S/N ratio in the inner coil eddy current testing deteriorates. Therefore, in order to increase the S/N ratio, it becomes necessary to roll to get a round tube as much as possible, i.e. much nearer

to the perfect round shape.

A second aspect is that, likewise as recited with reference to the foregoing Figs. 1 and 2, in the cold rolling process by pilger rolling, the tube materials are rolled during the intermittent-wise reciprocally rotating movement of roll-dies in the cold rolling process by pilger rolling, and thus, minute concave/convex irregularities of a saw-teeth shape are formed with a certain length-wise pitch on the tube inside surface, thereby worsening the S/N ratio in the inner coil eddy current testing.

Fig. 5 is a diagram schematically showing minute concave/convex irregularities of a saw-teeth shape to be formed on the tube inside surface due to the cold rolling process by pilger rolling. The minute concave/convex irregularities of a saw-teeth shape are attributable to the intermittent-wise reciprocally rotating movement of roll-dies, thus occurring with a reciprocation pitch of roll-dies. In this regard, in order to secure a high S/N ratio, it becomes necessary to minimize the concave/convex irregularities to be formed on the tube inside surface, or to avoid the generation of these irregularities.

As afore-mentioned, in order to increase the S/N ratio of metal tubes subjected to the cold rolling process by pilger rolling, it becomes necessary to improve the dimension-related shape characteristics (roundness) and surface property (suppression of the minute concave/convex irregularities of a saw-teeth shape). To that end, although it is possible to apply a cold drawing process as a final finishing process subsequent to the intermediate cold rolling process by pilger rolling, the trouble such as the slip and stick due to the lubrication performance during cold drawing likely occurs, thus increasing the work defective. Meanwhile, the adjusting-and-reforming die proposed in the Utility Model Publication No. 06-19902 can be one solution to be studied, but it involves the problems such as the modification/renovation of the equipment and the increase of manufacturing costs.

The present invention is attempted in view of the above problems, and its

object is to provide a cold rolling process for metal tubes wherein without requiring a new equipment/apparatus as well as without causing the decrease of the product yield and the increase of the manufacturing costs, a high dimensional accuracy, especially, the dimension-related shape characteristics and surface property of the tube inside surface, after the final finishing stage in pilger rolling is achieved, and a sufficiently high S/N ratio in the inner coil eddy current testing can be achieved.

Hence, the inventor et al precisely looked into the tool design (roll-dies, mandrel) and cold rolling parameters, and noticed that, in order to secure dimension-related shape characteristics (roundness) of the tube inside surface after the final finishing stage in pilger rolling and to secure excellent surface property, it is necessary to correlate the countermeasure for prevention of the oval appearance of the tube inside surface with the countermeasure for prevention of the minute concave/convex irregularities of a saw-teeth shape and to implement each optimal countermeasure independently.

In concrete, it is found that the countermeasure for preventing the oval appearance of the tube inside surface is to optimize the side relief rate SR of roll-dies and the feed rate F, while the countermeasure for preventing the minute concave/convex irregularities of a saw-teeth shape on the tube inside surface is to decrease the mandrel taper in its primary deformation zone as well as in the final size reduction zone and to optimize the feed rate F. In order to clarify the mutual relationship, following (Experiment 1) and (Experiment 2) are carried out.

#### (Experiment 1)

In the first place, the inventor et al carried out the experiment about the relationship between the side relief rate SR and the feed rate F, which are considered to be effective in preventing the oval appearance. As the test materials, the billets made of the materials corresponding to NCF690TB (30Cr – 60Ni) specified in JIS Standard are prepared, and subjected to hot extrusion process to yield the tube blanks of 55 mm in outside diameter x 32 mm in inside diameter, followed by grinding the outside surface thereof to make 54.75 mm in

outside diameter x 32 mm in inside diameter, to be the tube materials for pilger rolling.

The tube materials thus made are subjected to a preliminary rolling process to make the intermediate tubes of 25 mm in outside diameter x 19 mm in  
5 inside diameter, and in the subsequent final finishing rolling, employing the roll-die whose side relief rate SR is varied to 0%, 0.5%, 1.0%, 1.5% and 2.0% (5 variants in all) and the mandrel with the basic taper, the cold rolling is performed while the feed rate F is varied to 1.5 mm, 2.0 mm, 2.5 mm, 3.0 mm and 3.5 mm (5 variants in all).

10 As regards the parameters of the cold rolling process, the taper  $\theta_1$  in the primary deformation zone of the mandrel and the taper  $\theta_2$  in the final size reduction zone are adjusted to 0.3 degree respectively, and the metal tubes of 12.85 mm in outside diameter x 10.67 mm in inside diameter are rolled from the intermediate tubes of 25 mm in outside diameter x 19 mm in inside diameter.

15 Each inside surface of the tubes made by the final finishing rolling process is subjected to the inner coil eddy current testing under conditions of 750 kHz in frequency and the differential bobbin coil method, using the through-wall drill hole of 0.66 mm in diameter as the calibration standard or an artificial defect, and the S/N ratio is investigated. The results are shown in Table 1.

20

Table 1 (Taper  $\theta_1$ : 0.3 degree, Taper  $\theta_2$ : 0.3 degree)

S/N Ratio		Side Relief Rate SR (%)				
		0	0.5	1.0	1.5	2.0
Feed Rate F (mm)	1.5	OF occurrence	21	18	13	10
	2.0	OF occurrence	18	14	12	10
	2.5	OF occurrence	12	13	10	8
	3.0	OF occurrence	8	7	—	—
	3.5	OF occurrence	5	—	—	—

- (Note) 1) The word "OF" designates "Overfill".  
 2) The symbol "—" in the Table designates that the test run was not conducted.

5

As seen from the results shown in Table 1, when the mandrel with the basic taper in prior art is used, as the side relief rate SR gets larger, the S/N ratio becomes deteriorated more. Meanwhile, when the side relief rate SR becomes small to be less than 0.5%, the fin-like projections occur on the tube outside surface to be the overfill.

10

With regard to the relationship between the side relief rate SR and the feed rate F, as the side relief rate SR gets smaller, and as the feed rate F gets smaller, the higher S/N ratio can be obtained. Therefore, it is evident that, when the condition of  $F \leq \alpha - SR$  (namely,  $F + SR \leq \alpha$ ) is generally satisfied in the relationship between the side relief rate SR and the feed rate F, the higher S/N ratio can be obtained. For instance, according to the results shown in Table 1, to obtain S/N ratio of 15 or more (S/N Ratio  $\geq 15$ ), the relationship expressed by the equation  $F \leq 2.5 - SR$  ( $\alpha = 2.5$ ) must be satisfied.

15

(Experiment 2)

20

Secondly, the inventor et al made the experiment in such a way that each of the taper  $\theta_1$  in the primary deformation zone of the mandrel and the taper  $\theta_2$  in the final size reduction zone thereof is varied in the cold rolling process.

Similarly to Experiments 1, as the test materials, the intermediate tubes made of the materials corresponding to NCF690TB (30Cr – 60Ni) specified in JIS Standard are prepared, and in the subsequent final finishing rolling, under conditions that the roll-die whose side relief rate SR is adjusted to 0.5% is employed and the feed rate F is adjusted to 2.5 mm, the metal tubes of 12.85 mm in outside diameter x 10.67 mm in inside diameter are rolled from said intermediate tubes of 25 mm in outside diameter x 19 mm in inside diameter.

In this regard, the taper  $\theta_1$  in the primary deformation zone of the mandrel is varied to 0.1 degree to 0.3 degree (4 variants), while the taper  $\theta_2$  in the final size reduction zone is varied to 0.01 degree to 0.3 degree (4 variants). Similarly to Experiment 1, the S/N ratio of the metal tubes thus obtained is investigated, whereas the results are shown in Table 2.

Table 2 (Side Relief Rate SR: 0.5%, Feed Rate F: 2.5 mm)

S/N Ratio		Taper $\theta_2$ in the final size reduction zone (degree)			
		0.01	0.03	0.1	0.3
Taper $\theta_1$ in the primary deformation zone (degree)	0.3	15	13	12	12
	0.25	21	19	17	14
	0.2	22	19	19	16
	0.1	22	19	19	16

15

As seen from the results shown in Table 2, it is evident that as either the taper  $\theta_1$  in the primary deformation zone of the mandrel or the taper  $\theta_2$  in the final size reduction zone or both get smaller, the S/N ratio becomes higher. It reveals that, in comparison with the case that when the mandrel with the basic taper (Experiment 1) is adopted, the side relief rate SR is 0.5% and the feed rate F is 2.5 mm, the S/N ratio remains to be 12, decreasing both the taper  $\theta_1$  in the

20

primary deformation zone of the mandrel and the taper  $\theta_2$  in the final size reduction zone can ensure the higher S/N ratio.

In other words, the relationship between the side relief rate SR and the feed rate F, namely, the condition that the relationship  $F \leq 2.5 - SR$  must be met in obtaining S/N ratio of 15 or more (S/N Ratio  $\geq 15$ ) is premised on the mandrel with the basic taper, thereby indicating that decreasing the taper of the mandrel can enlarge the applicable scope determined by this relationship.

The present invention is completed based on the above investigations, and its gist pertains to the cold rolling process for metal tubes described as below.

Namely, it is intended to provide a cold rolling process for metal tubes in which the cold rolling process by pilger rolling that employs a pair of roll-dies with a roll caliber consisted of a roll caliber diameter Dx and a side relief amount Fx and holds a mandrel between each of said roll-dies is applied as a final finishing rolling process, wherein a side relief rate SR of said roll-dies expressed by the equation [1] as below is set in the range of 0.5 to 1.5%, and wherein a taper  $\theta_1$  in the primary deformation zone of said mandrel is set to 0.25 degree or less, and a taper  $\theta_2$  in the final size reduction zone of said mandrel is set to 0.1 degree or less, and wherein a feed rate (per one pass) of a workpiece material is set in the range of 1.0 to 2.5 mm, the relationship between the side relief rate SR and the feed rate F expressed by the equation [2] as below being satisfied:

$$SR (\%) = \{(2 \times Fx) / (2 \times Fx + Dx)\} \times 100 \quad [1]$$

$$F \leq 3.0 - SR. \quad [2]$$

According to the cold rolling process for metal tubes by the present invention, by optimizing the side relief rate SR of roll-dies, the mandrel factors like the taper  $\theta_1$  in the primary deformation zone and the taper  $\theta_2$  in the final size reduction zone of said mandrel, and the feed rate F of the workpiece material, and at the same time by properly adjusting the relationship between the side relief rate SR and the feed rate F, it becomes possible to secure good dimensional accuracy (near perfect roundness) of the tube inside surface after the final

finishing process by pilger rolling without requiring a new equipment/apparatus as well as without causing the reduction of the product yield and the increase of the manufacturing costs, thereby enabling to secure excellent surface property. Thus, it becomes possible to ensure a sufficiently high S/N ratio in the inner coil eddy current testing for steam generator tubes in Nuclear Power Plant.

#### BREIF DESCRIPTION OF THE DRAWINGS

Fig. 1 is a diagram explaining the overall configuration of a pair of roll-dies to be used in pilger rolling.

Fig. 2 is a diagram showing a developed view of the roll caliber of the roll-die in order to explain how the tube material is rolled in pilger rolling.

Fig. 3 is a diagram showing a model of roll to be utilized in designing the caliber profile of roll-die.

Fig. 4 is a diagram showing the model configuration of an inner coil eddy current testing apparatus to be applied for the periodic in-service inspection of steam generator tubes in Nuclear Power Plant.

Fig. 5 is a diagram schematically showing minute concave/convex irregularities of a saw-teeth shape to be formed on the inside surface of tube due to the cold rolling process by pilger rolling.

Fig. 6 is a diagram showing the relationship between the S/N ratio and the side relief rate SR, using the feed rate F as a parameter, which is investigated in EXAMPLES.

#### DETAILED DESCRIPTION OF THE PREFERRED EMBODIMENTS

In the cold rolling process according to the present invention, it is featured that in order to secure good dimensional accuracy (roundness) of the tube inside surface after the final finishing step by pilger rolling and to ensure an excellent surface property, the countermeasure for preventing the oval appearance and the one for preventing the minute concave/convex irregularities of a saw-teeth shape

are optimized and the interrelation between each of countermeasures is properly adjusted. In the following, the details are recited.

In the cold rolling process according to the present invention, as shown in Fig. 3, the side relief rate SR expressed by the equation [1] needs to be set in the range of 0.5 to 1.5%, where the roll caliber diameter is given by Dx and the side relief amount is given by Fx.

While the smaller side relief rate SR enables to suppress the oval appearance of the tube inside surface, the condition of 0.5% or below causes a fin-like projection on the tube outside surface, the so-called overfill takes place, so that the cold rolling cannot be carried out successfully. Meanwhile, in the case that the side relief rate SR exceeds 1.5%, the oval appearance of the tube inside surface comes to be excessive, thus deteriorating the S/N ratio. Thus, the preferable range of the side relief rate SR is 0.5 to 1.0%.

$$SR (\%) = \{(2 \times Fx) / (2 \times Fx + Dx)\} \times 100 \quad [1]$$

The side relief rate SR specified in the present invention is allowed to be calculated by the caliber profile factor (Dx, Fx) at least at the position corresponding to the rolling-work completion region, i.e., the deformation ending position "b". The side relief rate SR at other rolling-work region of the roll-die need not be specifically defined, but is preferably set in the range of 0.5 to 1.5%.

In the cold rolling process according to the present invention, in order to suppress minute concave/convex irregularities of a saw-teeth shape on the tube inside surface, it is required that the taper  $\theta_1$  of the primary deformation zone of the mandrel is set to 0.25 degree or less, and the taper  $\theta_2$  of the final size reduction zone thereof is set to 0.1 degree or less. Further, it is preferable that the taper  $\theta_1$  of the primary deformation zone of the mandrel is set to 0.2 degree or less, and the taper  $\theta_2$  of the final size reduction zone thereof is set to 0.05 degree or less.

The reason is that: As shown in the foregoing Fig. 2, in the case that the primary deformation zone as well as the final size reduction zone of the mandrel is

provided with a continuous taper, it is commonly known that the concave/convex of a saw-teeth shape is imprinted onto the tube inside surface every each stroke of the reciprocally rotating movement of roll-dies. Hence, as each of said tapers becomes smaller, the formation of the minute concave/convex irregularities is suppressed further, and the high S/N ratio can be achieved.

In the cold rolling process according to the present invention, although each lower limit of the taper  $\theta_1$  in the primary deformation zone of the mandrel and the taper  $\theta_2$  in the final size reduction zone thereof is set to zero degree, it is preferable that the taper  $\theta_1$  in the primary deformation zone is set to have a tapered configuration because the deformation work in reducing the radius of the tube material takes place in the manner of following the shape of the primary deformation zone of the mandrel to thereby ensure a high dimensional accuracy. In this regard, it is much preferable that the lower limit of the taper  $\theta_1$  in the primary deformation zone is set to 0.1 degree.

Meanwhile, as regards the taper  $\theta_2$  in the final size reduction zone, the slightly tapered configuration is effective to prevent the generation of the sticking and/or scratch imperfection on the tube inside surface by the contact with the mandrel after the cold rolling. In this regard, it is much preferable that the lower limit of the taper  $\theta_2$  in the final size reduction zone is set to 0.01 degree.

Further, in the cold rolling process according to the present invention, in order to suppress the oval appearance of the tube inside surface as well as to suppress the minute concave/convex irregularities of a saw-teeth shape, the feed rate  $F$  of the workpiece material (per one pass) needs to be properly selected.

Decreasing the feed rate  $F$  of the workpiece makes it possible to suppress the formation of the minute concave/convex irregularities on the tube inside surface, but ends up in lowering the productivity, thus being unable to be the base parameter for production. On the other hand, increasing the feed rate  $F$  can enhance the productivity, but results in making larger the minute concave/convex irregularities formed on the tube inside surface, thus reducing the S/N ratio.

Accordingly, in the cold rolling process according to the present invention, the feed rate  $F$  of the workpiece is set in the range of 1.0 to 2.5 mm. Further, the preferable feed rate  $F$  is in the range of 1.0 to 2.0 mm.

Further, in the cold rolling process according to the present invention, the relationship between the feed rate  $F$  and the side relief rate  $SR$  must satisfy the equation [2] as below:

$$F \leq 3.0 - SR. \quad [2]$$

As seen from the results of the forgoing Experiments 1 and 2, the conformance with the relationship expressed by the above equation [2] can efficiently ensure high S/N ratio, on the premise of decreasing the taper both in the primary deformation zone and in the final size reduction zone of the mandrel. Further, to assuredly ensure the high S/N ratio, it is preferable that the relationship between the feed rate  $F$  and the side relief rate  $SR$  satisfies the equation [3] as below:

$$F \leq 2.5 - SR. \quad [3]$$

## EXAMPLES

In Example, the S/N ratio is investigated for the metal tubes manufactured by finishing rolling which applies the process according to the present invention. As the test materials, the billets made of the materials corresponding to NCF690TB (30Cr – 60Ni) specified in JIS Standard are prepared, and subjected to hot extrusion process to yield the tube blanks of 55 mm in outside diameter x 32 mm in inside diameter, followed by grinding the outside surface thereof to make 54.75 mm in outside diameter x 32 mm in inside diameter, to be the tube materials for pilger rolling.

The tube materials thus made are subjected to a preliminary rolling process to make the intermediate tubes of 25 mm in outside diameter x 19 mm in inside diameter. In the subsequent final finishing rolling, the roll-dies whose side relief rate  $SR$  are varied to 0.5%, 1.0%, 1.5% and 2.0% (4 variants in all) and the

mandrel where the taper  $\theta_1$  in the primary deformation zone is adjusted to 0.25 degree and the taper  $\theta_2$  in the final size reduction zone is adjusted to 0.1 degree are employed to make the metal tubes of 12.85 mm in outside diameter x 10.67 mm in inside diameter by the finishing rolling. In the mean time, the feed rate  $F$  is varied to 1.0 mm, 1.5 mm, 2.0 mm and 2.5 mm (4 variants).

Each inside surface of the tubes made by the final finishing rolling process with parameters shown in Table 3 is subjected to the inner coil eddy current testing employing 750 kHz in frequency and the differential bobbin coil method, wherein the through-wall drill hole of 0.66 mm in diameter is used as the calibration standard or an artificial defect and the S/N ratio is investigated. The results are shown in Table 3.

Table 3 (Taper  $\theta_1$ : 0.25 degree, Taper  $\theta_2$ : 0.1 degree)

S/N Ratio		Side Relief Rate SR (%)			
		0.5	1.0	1.5	*2.0
Feed Rate F (mm)	1.0	28	23	18	14
	1.5	26	19	16	11
	2.0	21	18	12	9
	2.5	17	13	10	8

(Note) The symbol \* denotes the deviation from the specified range by the present invention.

As seen from the results shown in Table 3, it is evident that as the side relief rate SR becomes larger, the ovality of the tube inside surface increases, and as the feed rate  $F$  gets larger, the ovality of the tube inside surface increases and the formation of minute concave/convex irregularities of a saw-teeth shape is accelerated, thus resulting in the decrease of the S/N ratio.

Fig. 6 is a diagram showing the relationship between the S/N ratio and the side relief rate SR, using the feed rate  $F$  as a parameter, which is investigated in

EXAMPLES. As being evident from this diagram, the conditions that the side relief rate SR is set in the range of 0.5 to 1.5% while the feed rate F is set in the range of 1.0 to 2.5 mm, preferably the feed rate F being set in the range of 1.0 to 2.0mm, can ensure the high S/N ratio, but all of the conditions cannot always meet  
5 S/N Ratio  $\geq 15$ .

Therefore, in the process according to the present invention, in order to always satisfy S/N Ratio  $\geq 15$  under conditions that the taper  $\theta_1$  in the primary deformation zone of the mandrel is 0.25 degree or less and the taper  $\theta_2$  in the final size reduction zone is 0.1 degree or less, the side relief rate SR and the feed rate F  
10 must meet the relationship expressed by the equation  $F \leq 3.0 - SR$  besides the individual limitation as above.

As recited as above, by optimizing the side relief rate SR, the mandrel factors like the taper  $\theta_1$  in the primary deformation zone of the mandrel and the taper  $\theta_2$  in the final size reduction zone thereof, and the feed rate F of the  
15 workpiece material, and at the same time by properly adjusting the relationship between the side relief rate SR and the feed rate F, the cold rolling process for metal tubes according to the present invention can secure the dimension-related shape characteristics (near-perfect round shape) of the tube inside surface after the final finishing rolling process by pilger rolling to ensure excellent surface  
20 property without requiring a new apparatus, and further without causing the decrease of the product yield and/or the increase of the manufacturing costs. Thus, this can be widely applied for producing steam generator tubes which exhibit high S/N ratio in the inner coil eddy current testing.

## CLAIMS

1. A cold rolling process for metal tubes in which the cold rolling process by pilger rolling that employs a pair of roll-dies with a roll caliber comprising a roll caliber diameter  $D_x$  and a side relief amount  $F_x$  and holds a mandrel between  
 5 each of said roll-dies is applied as a final finishing process, characterized in that a side relief rate  $SR$  of said roll-dies expressed by the equation [1] as below is set in the range of 0.5 to 1.5%, and

said mandrel is configured in such a way that a taper  $\theta_1$  in the primary deformation zone of said mandrel is set to 0.25 degree or less, and a taper  $\theta_2$  in the  
 10 final size reduction zone of said mandrel is set to 0.1 degree or less, and

a feed rate  $F$  (per one pass) of a workpiece material is set in the range of 1.0 to 2.5mm, the relationship between the side relief  $SR$  and the feed rate  $F$  expressed by the equation [2] as below being satisfied:

$$SR (\%) = \{(2 \times F_x) / (2 \times F_x + D_x)\} \times 100 \quad [1]$$

$$15 \quad F \leq 3.0 - SR \quad [2]$$

2. A cold rolling process for metal tubes according to claim 1, characterized in that a  $S/N$  ratio is 15 or more when an eddy current testing by means of the eddy current testing apparatus comprising 750 kHz in frequency and the differential bobbin coil method is carried out, using a through-wall drill hole of 0.66 mm in  
 20 diameter as a calibration standard or an artificial defect, for each inside surface of said metal tubes made by the final finishing rolling process.

FIG. 1

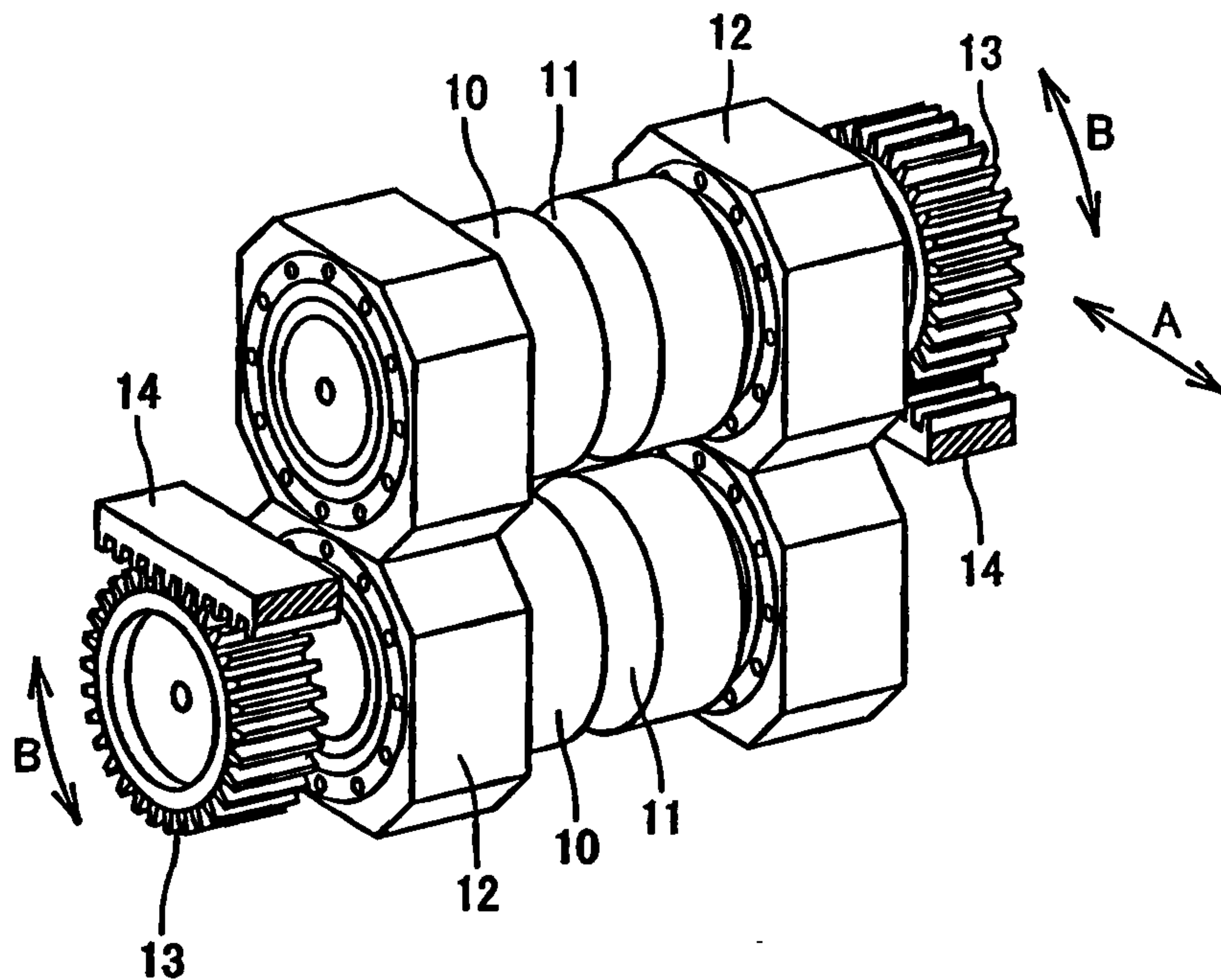

FIG. 2

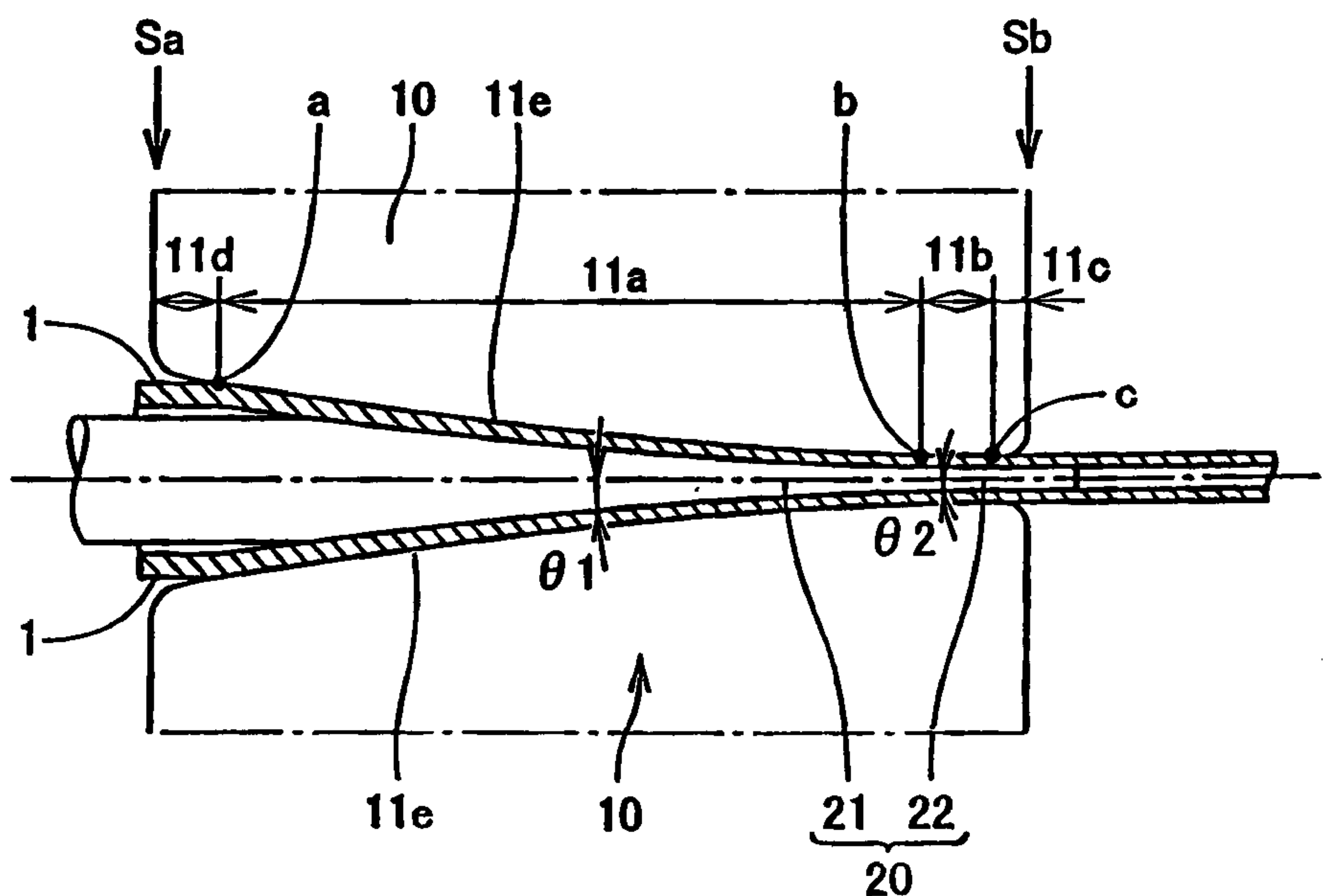

FIG. 3

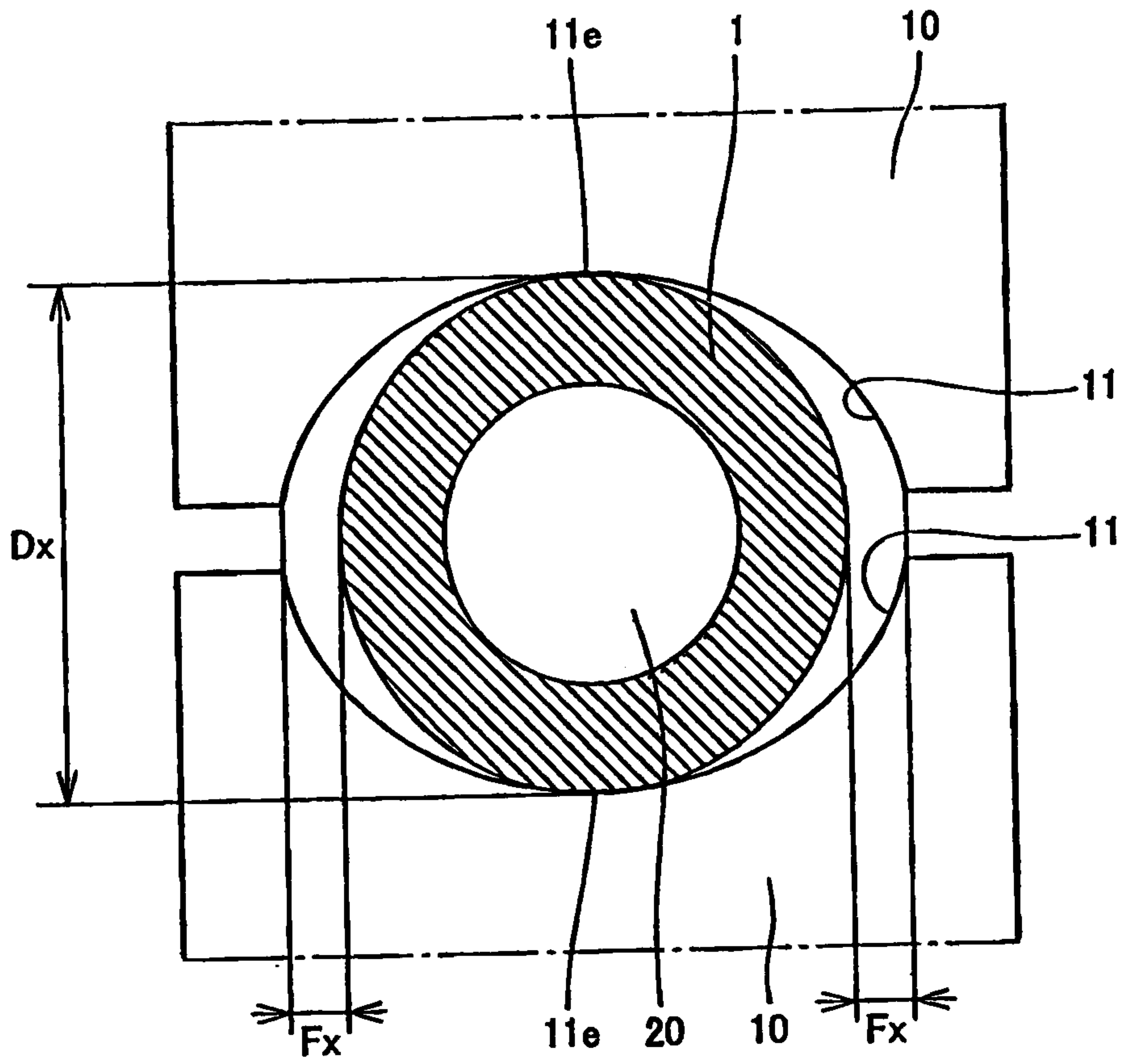

FIG. 4

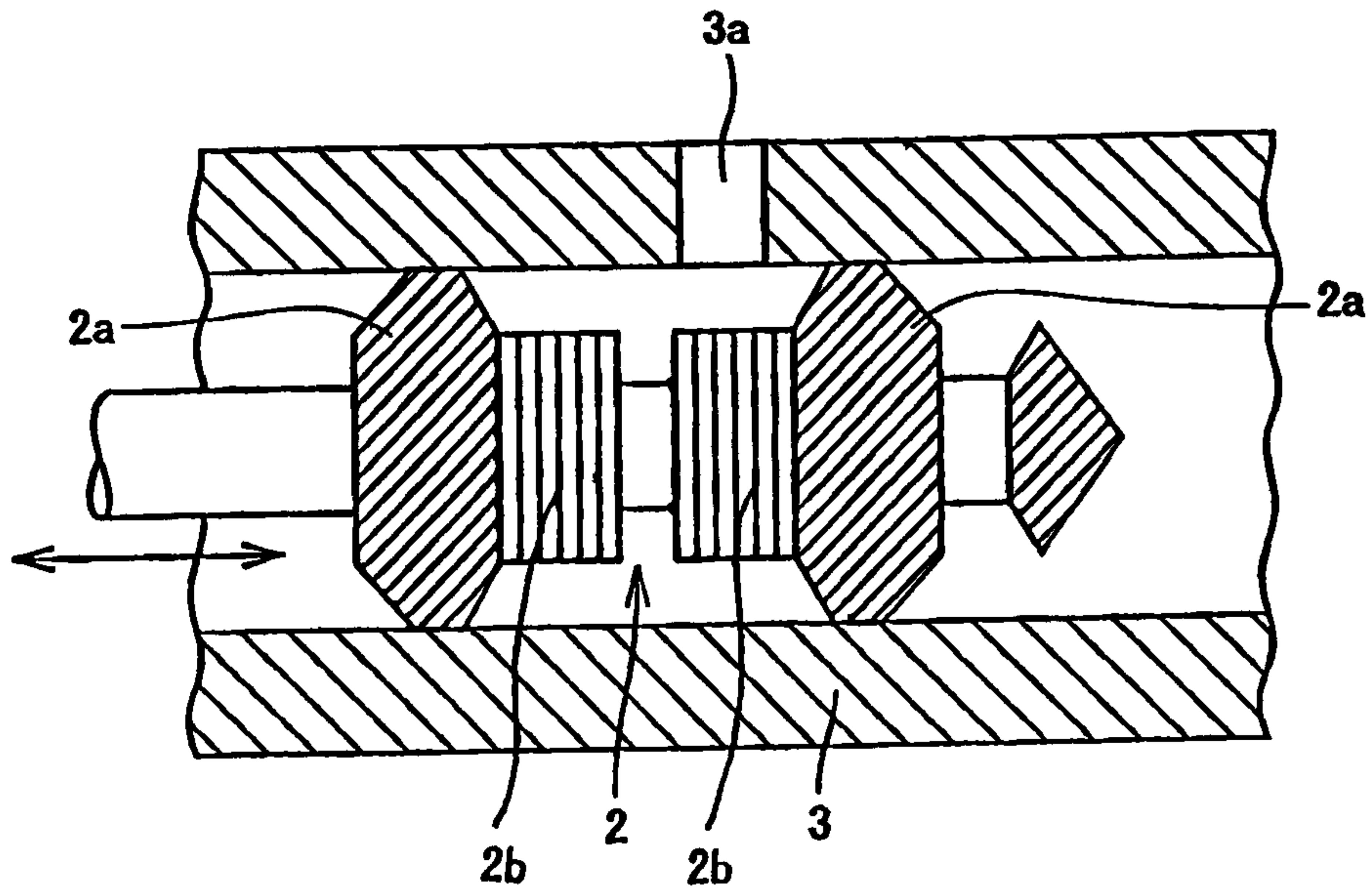

FIG. 5

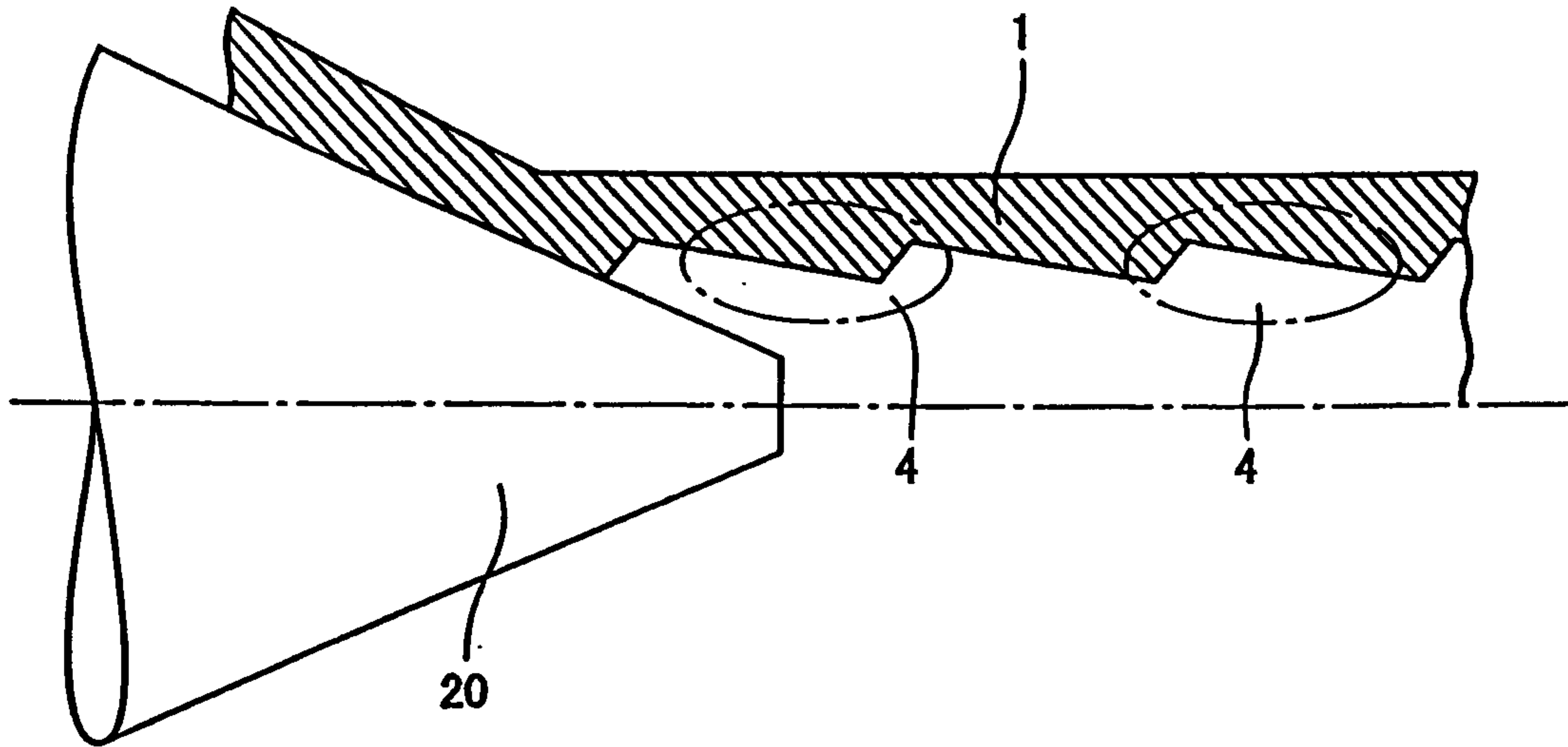

FIG. 6

