

Dec. 27, 1932.

J. C. GARAND

1,892,141

SEMI-AUTOMATIC RIFLE

Filed April 21, 1930

9 Sheets-Sheet 2

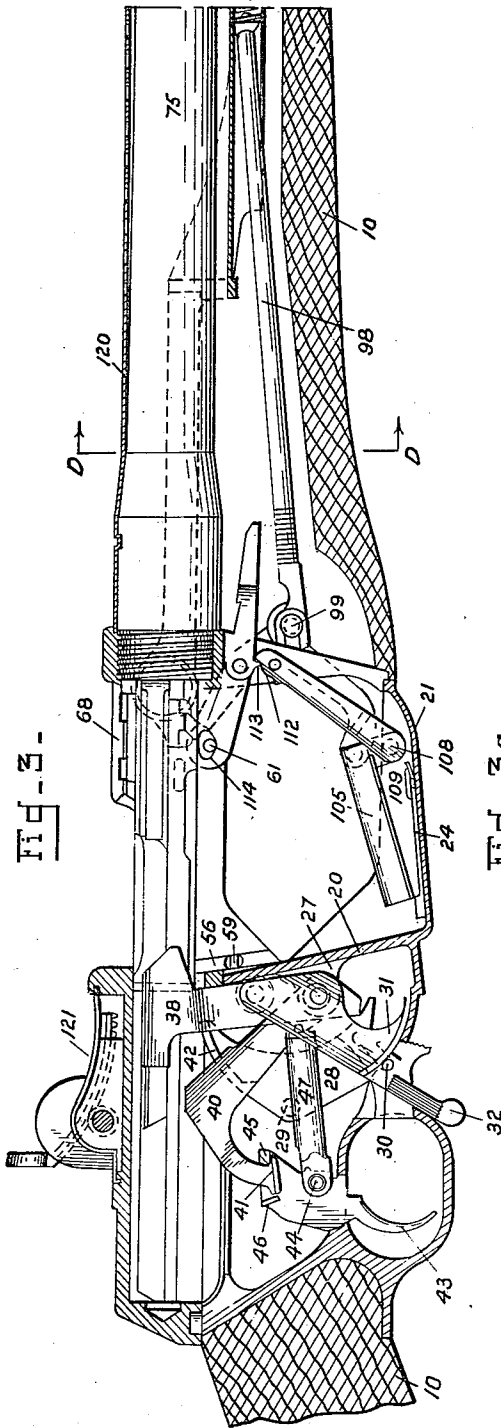

FIG. 2 -

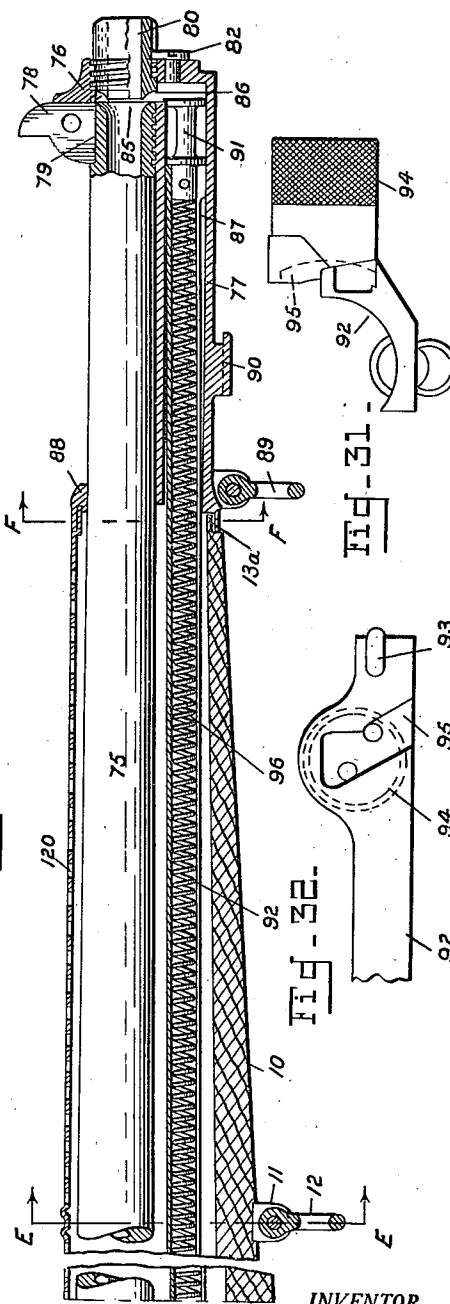

FIG. 3a -

INVENTOR.

John C. Garand

BY *W. N. Roach*
ATTORNEY

Dec. 27, 1932.

J. C. GARAND

1,892,141

SEMI-AUTOMATIC RIFLE

Filed April 21, 1930

9 Sheets-Sheet 3

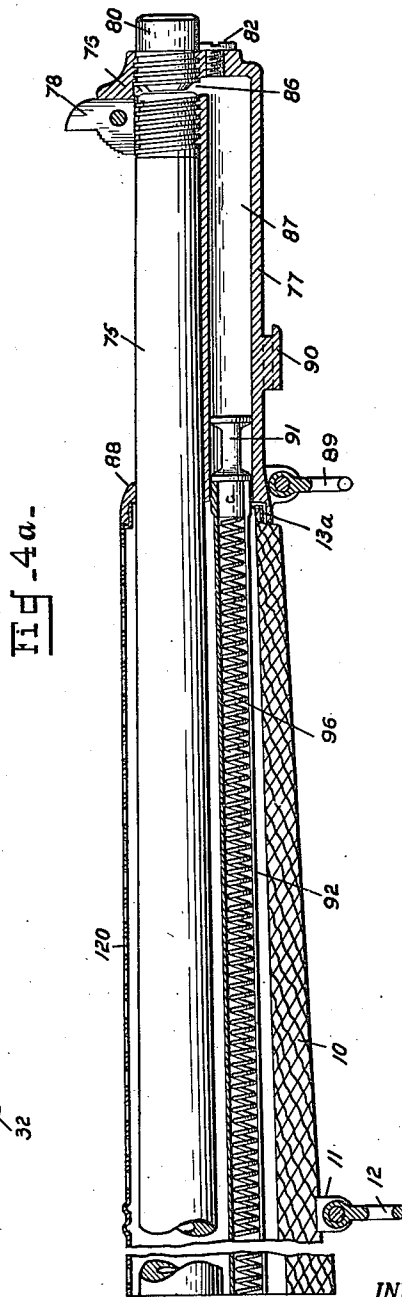
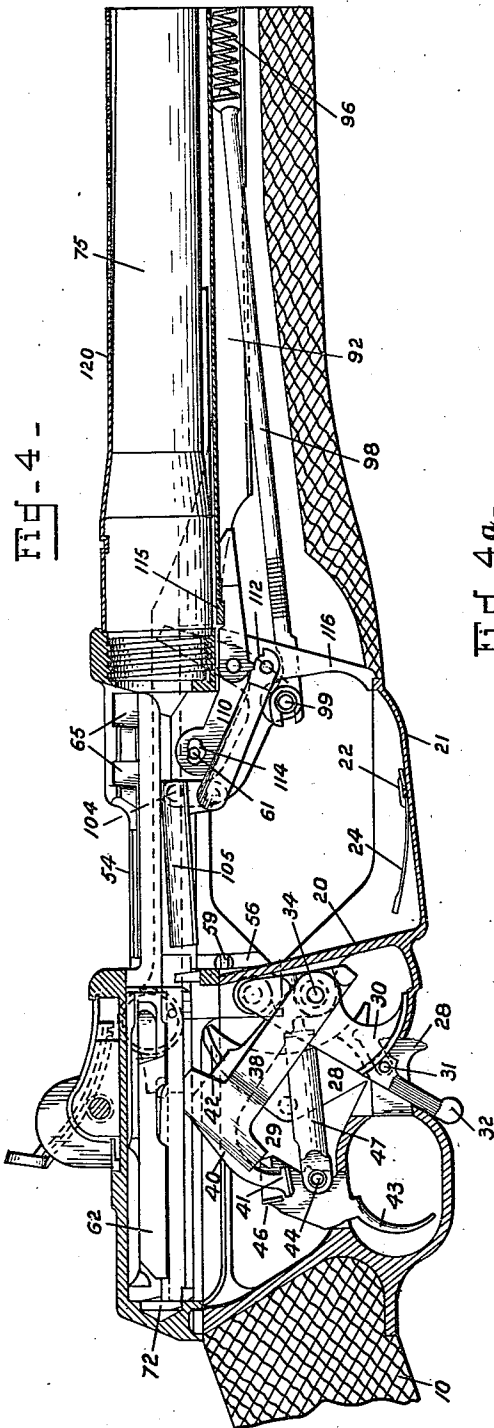

INVENTOR.
John C. Garand
BY *W. N. Roach*
ATTORNEY

Dec. 27, 1932.

J. C. GARAND

1,892,141

SEMI-AUTOMATIC RIFLE

Filed April 21, 1930

9 Sheets-Sheet 4

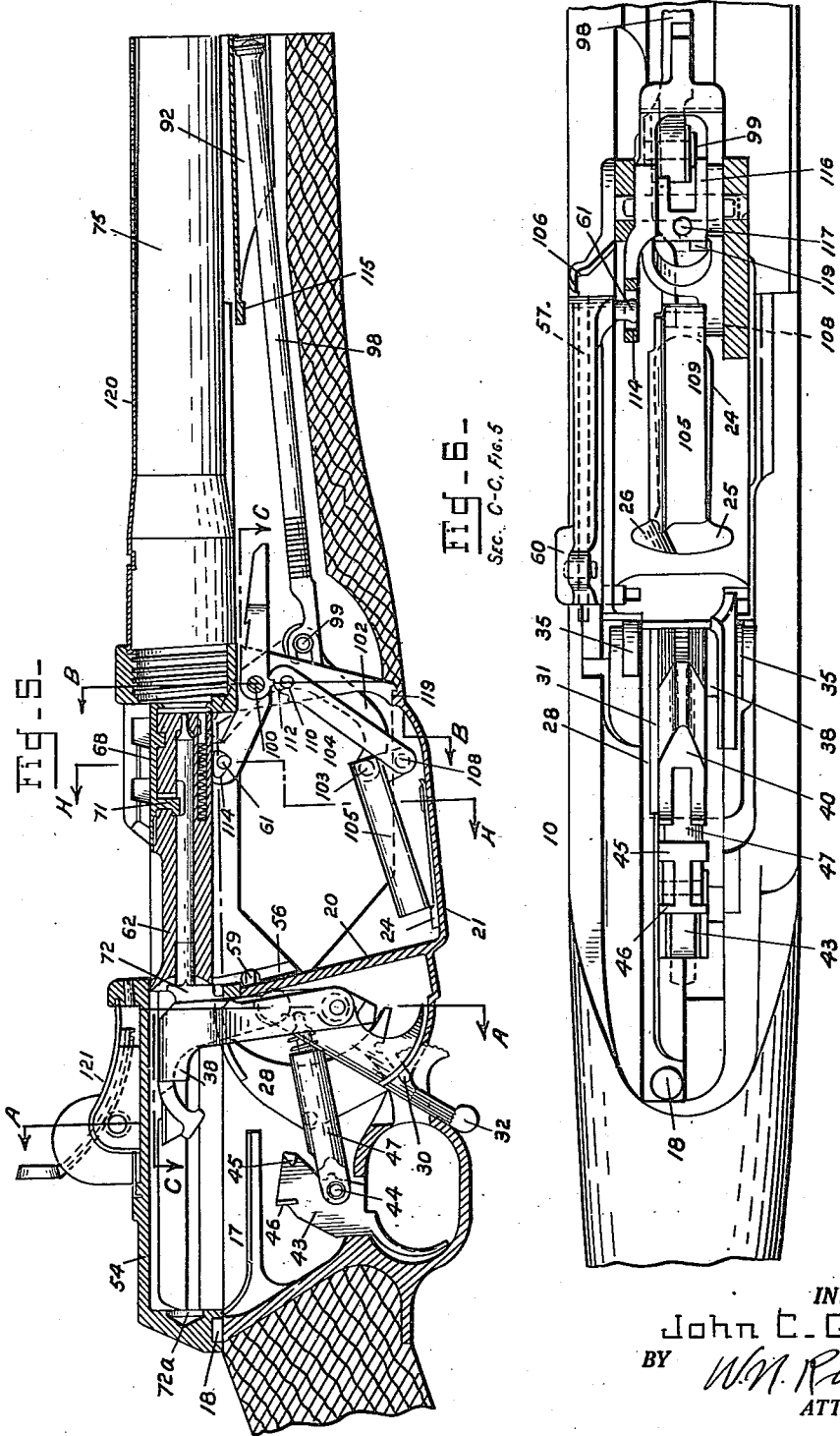

INVENTOR.
John C. Garand
BY *W.M. Roach*
ATTORNEY

Dec. 27, 1932.

J. C. GARAND

1,892,141

SEMI-AUTOMATIC RIFLE

Filed April 21, 1930

9 Sheets-Sheet 5

Fig. 7

Sec. A-A, Fig. 5

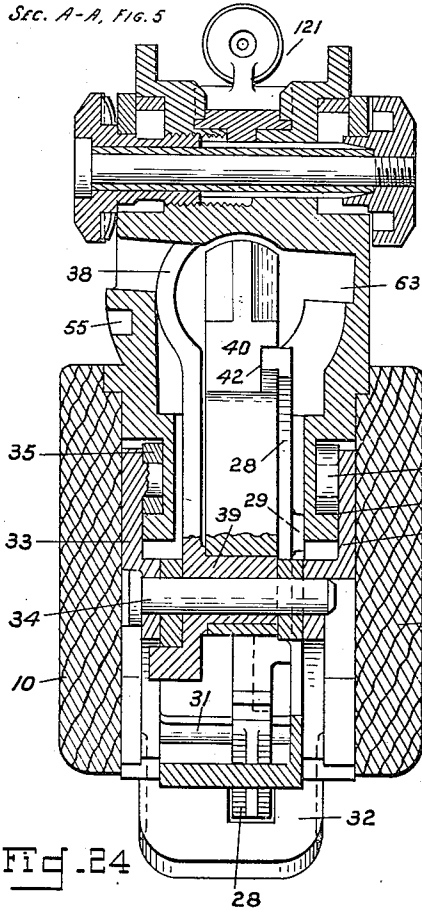

Fig. 8

Sec. B-B, Fig. 5

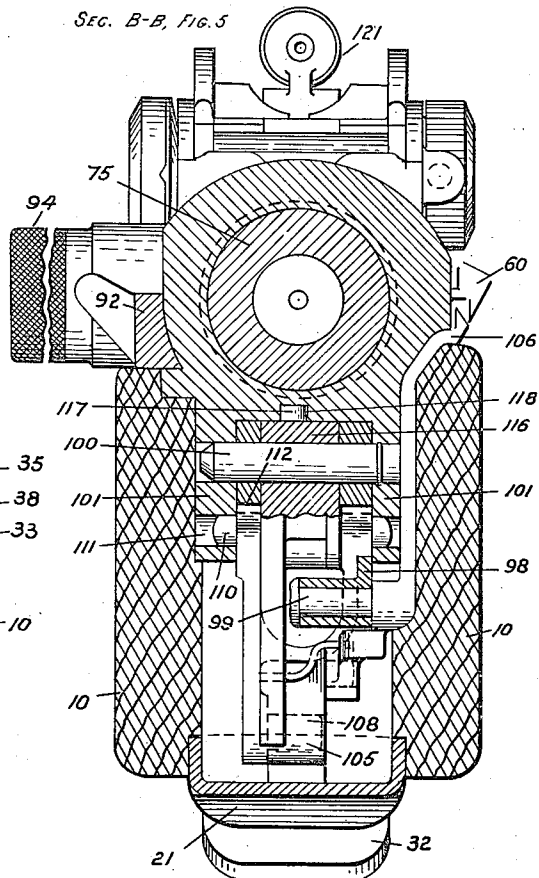

Fig. 24

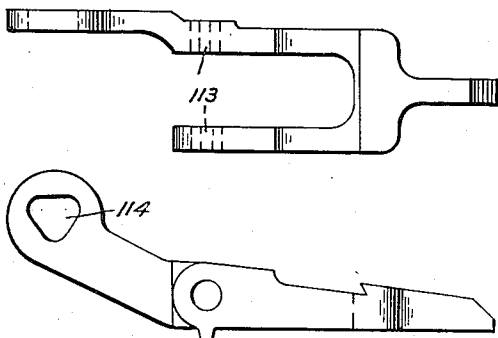

Fig. 25. 113

Fig. 26.



INVENTOR.
 John C. Garand
 BY *W. N. Roach*
 ATTORNEY

Dec. 27, 1932.

J. C. GARAND

1,892,141

SEMI-AUTOMATIC RIFLE

Filed April 21, 1930

9 Sheets-Sheet 6

Fig. 9.
SEC. H-H, FIG. 5

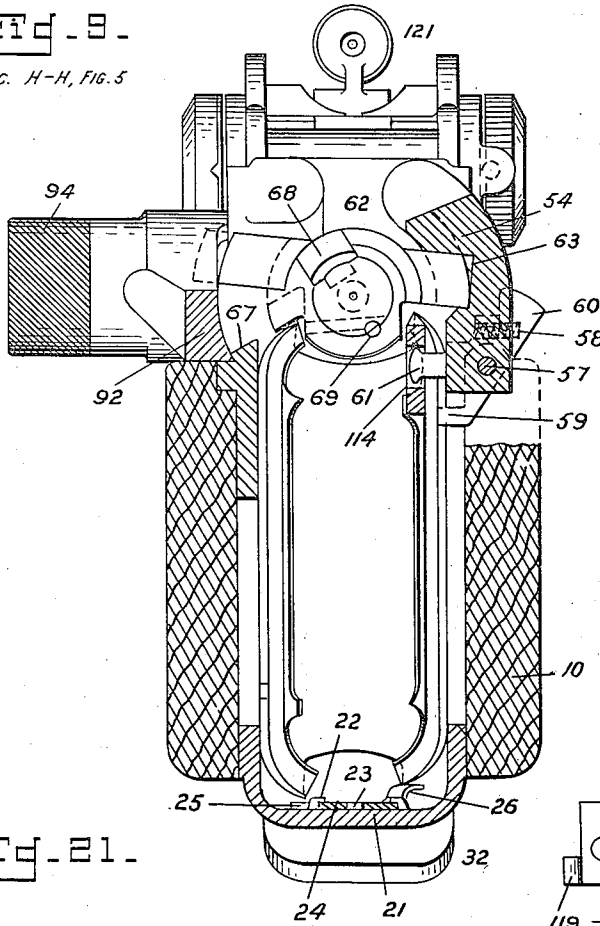

Fig. 21.

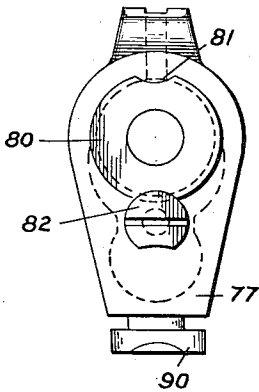
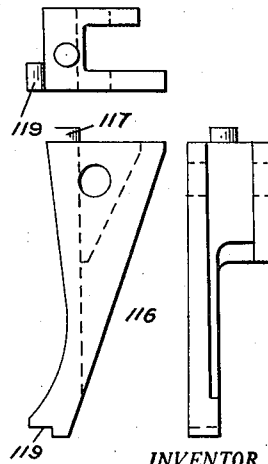

Fig. 22.



INVENTOR.
John C. Garand
BY *W. N. Roach*
ATTORNEY

Dec. 27, 1932.

J. C. GARAND
SEMI-AUTOMATIC RIFLE

1,892,141

Filed April 21, 1930

9 Sheets-Sheet 7

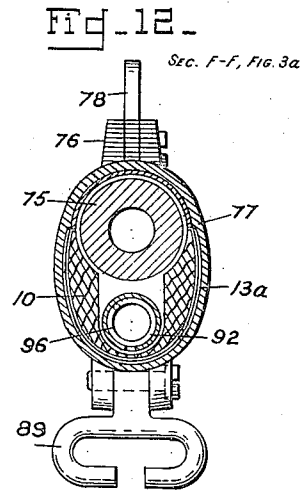
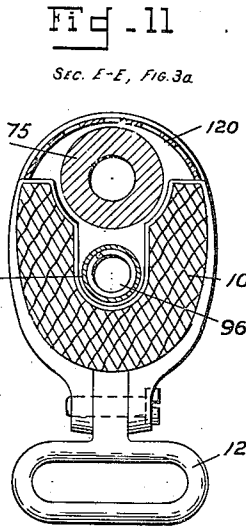
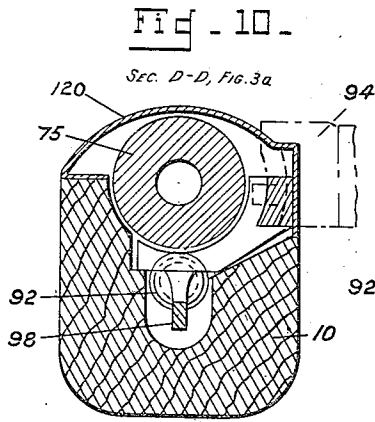

Fig. 13.

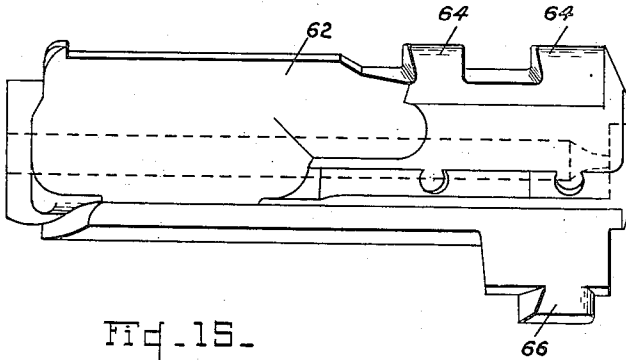

Fig. 14.

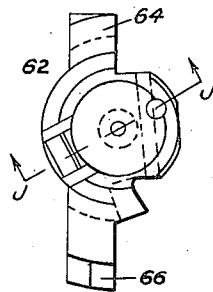

Fig. 15.

Sec. J-J, Fig. 14

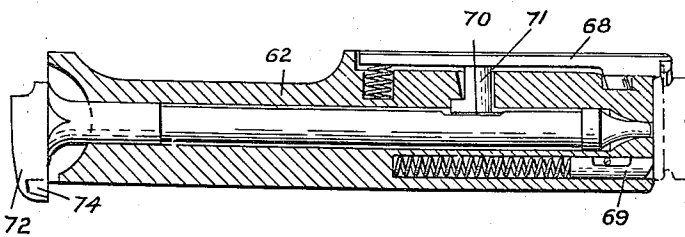
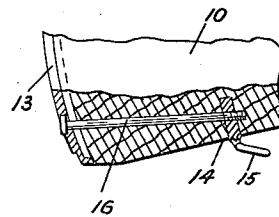

Fig. 27.



INVENTOR.
John C. Garand
BY *W. N. Poach*
ATTORNEY

Dec. 27, 1932.

J. C. GARAND
SEMI-AUTOMATIC RIFLE

1,892,141

Filed April 21, 1930

9 Sheets-Sheet 8

Fig. 16.

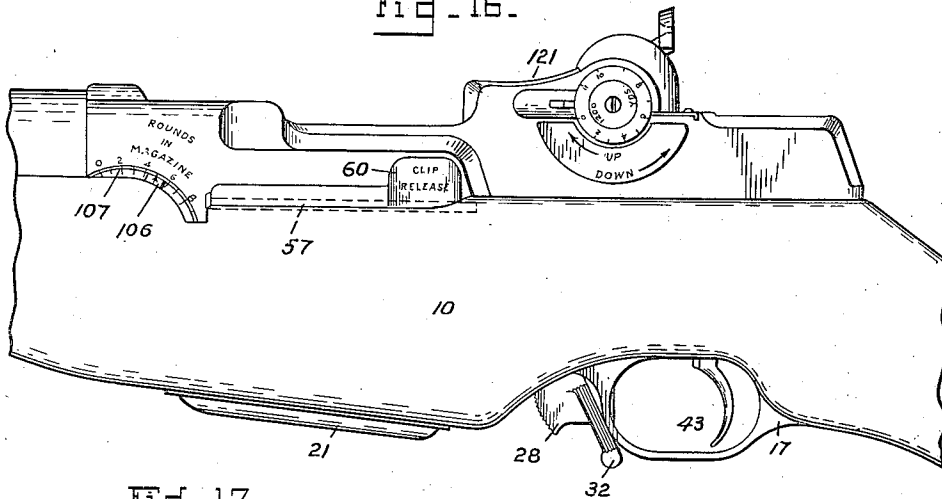

Fig. 17.

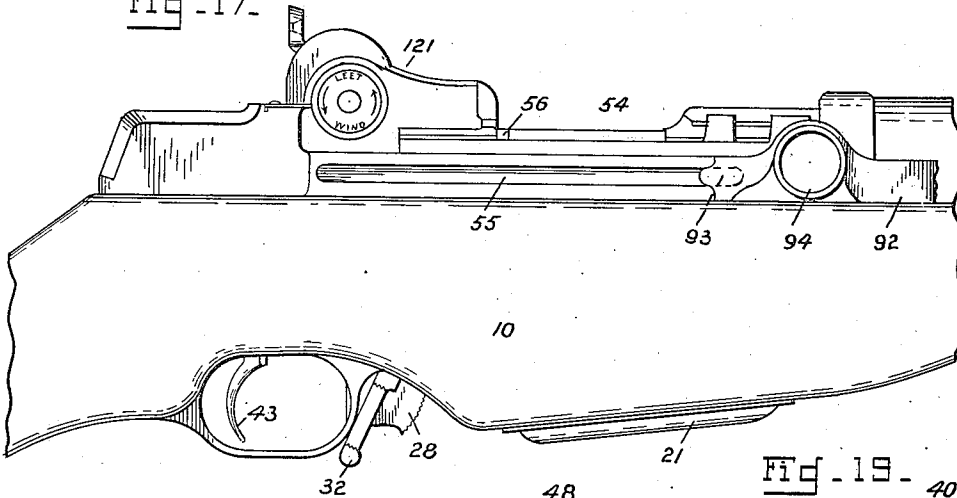

Fig. 19.

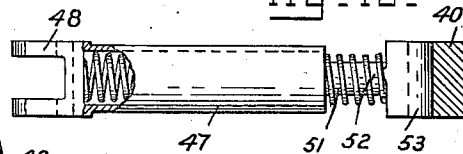
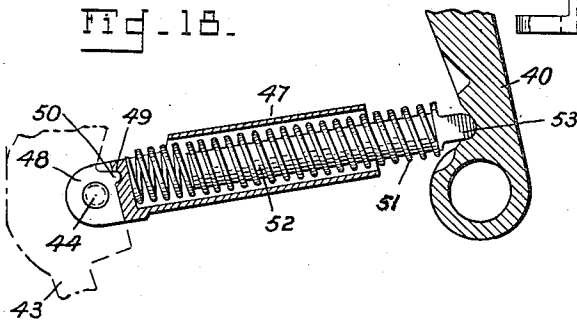

Fig. 18.



INVENTOR.
John C. Garand
BY *W. M. Roach*
ATTORNEY

Dec. 27, 1932.

J. C. GARAND

1,892,141

SEMI-AUTOMATIC RIFLE

Filed April 21, 1930

9 Sheets-Sheet 9

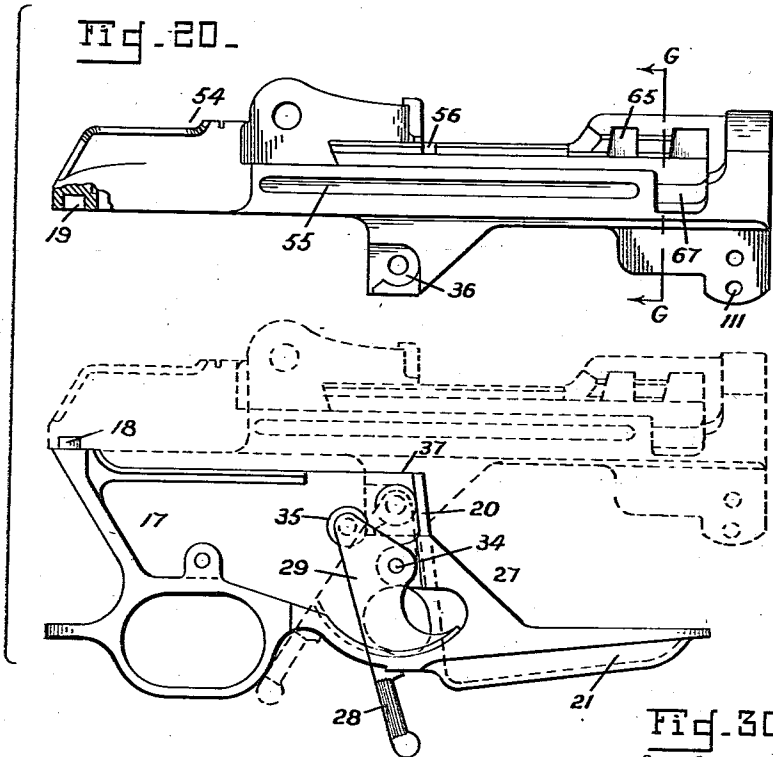

Fig. 30.
Sec. G-G, Fig. 20

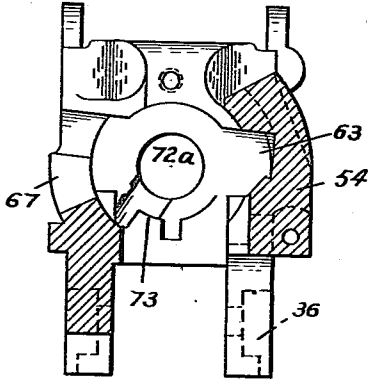
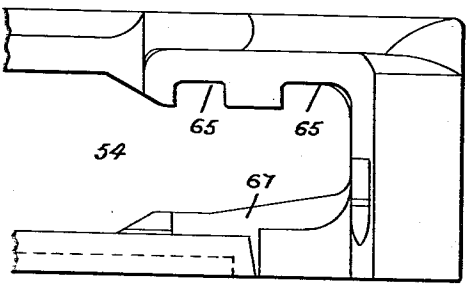

Fig. 29.



INVENTOR
John C. Garand
BY *W. N. Road*
ATTORNEY

UNITED STATES PATENT OFFICE

JOHN C. GARAND, OF SPRINGFIELD, MASSACHUSETTS

SEMIAUTOMATIC RIFLE

Application filed April 21, 1930. Serial No. 446,079.

(GRANTED UNDER THE ACT OF MARCH 3, 1883, AS AMENDED APRIL 30, 1928; 370 O. G. 757)

The invention described herein may be manufactured and used by or for the Government for governmental purposes, without the payment to me of any royalty thereon.

5 The subject of this invention is a firearm and more specifically a firearm of the gas actuated type.

With the average firearm, especially a shoulder arm, there is always danger of the stock being deflected through warping or through the strain placed thereon by the user particularly in the prone position when using the sling. This distortion of the stock is detrimental to accurate shooting by reason of the fact that the barrel is so connected to the stock as to be thrown out of line. This defect is overcome in the present instance by allowing the barrel to be free from the stock, being supported therein only by the receiver. Another advantage of this construction resides in the fact that the gun may be disassembled without disturbing the sling or having the sling connecting different elements of the disassembled structure.

15 In the construction of the present firearm there has been provided a novel guard and trigger assembly which may be secured to or removed from the receiver as a unit and in which there is provided a latch for firmly securing the unit to the receiver, a safety which also serves to hold the latch in latching position and simple resilient means for holding the trigger, actuating the striker and safety, and performing other functions.

25 The invention also contemplates providing novel means for actuating the breech bolt automatically together with means for adjusting or regulating the action of such means or cutting off such action entirely. There is also provided mechanism for moving ammunition into position to be fed into the cartridge chamber so constructed that the follower is always in the proper angular position to contact the ammunition at its lower surface and such means also serve to operate means whereby the bolt operating mechanism is locked in bolt retracted position when the last cartridge has been ejected from the arm and further serve to move an indicator to po-

sitions that disclose the number of rounds of ammunition left in the clip.

The element for holding the ammunition clip in place is so constructed that it will be automatically released when the last cartridge has left the clip and means are provided for automatically ejecting the clip when so released.

The firing pin and bolt assembly are so designed that the firing pin is always in safe position when the bolt is unlocked.

The invention also contemplates the provision of a novel striker and trigger construction which allows the striker to be engaged and held by the trigger even though the trigger is still retained in retracted position when the striker is thrown back, and to still hold the striker when the trigger is then released. A novel upper band is provided mounting the front sight by which it is locked in position on the barrel.

With these and such other objects in view as may hereinafter more fully appear the invention resides in the novel arrangement and combination of parts and in the details of construction hereinafter described and claimed, it being understood, however, that changes in the precise embodiment of the invention herein disclosed may be made within the scope of what is claimed without departing from the spirit of the invention.

One practical embodiment of the invention is disclosed by way of illustration in the accompanying drawings, wherein:

Fig. 1 is a view in side elevation showing the right side of a firearm constructed in accordance with the invention;

Fig. 2 is a similar view showing the left side;

Figs. 3 and 3a are respectively fragmentary vertical longitudinal sections of the breech and muzzle portions of the firearm, the parts shown in normal fully loaded position with the breech closed;

Figs. 4 and 4a are similar views with the parts shown in position assumed when the clip has been emptied and the firearm is ready for reloading;

Fig. 5 is a fragmentary longitudinal sec-

55

60

65

70

75

80

85

90

95

100

tion showing the position of the parts at the instant of firing;

Fig. 6 is a sectional view taken on the line C—C of Fig. 5;

5 Fig. 7 is a transverse section taken on the line A—A of Fig. 5;

Fig. 8 is a transverse section taken on the line B—B of Fig. 5;

Fig. 9 is a section taken on the line H—H of Fig. 5, showing the clip in place;

10 Fig. 10 is a sectional view taken on the line D—D of Fig. 3;

Figs. 11 and 12 are similar views taken respectively on the lines E—E and F—F of Fig. 3a;

Fig. 13 is a plan view of the bolt;

Fig. 14 is a front elevation of same;

Fig. 15 is a section taken on the line J—J of Fig. 14;

20 Fig. 16 is a fragmentary view in side elevation of the left side of the firearm;

Fig. 17 is a similar view of the right side;

Fig. 18 is a longitudinal section of the resilient element interposed between the trigger and striker, fragments of which are shown;

Fig. 19 is a plan view thereof, the striker shown in section;

30 Fig. 20 is a disassembled view in side elevation of the receiver and guard, the assembled position of the receiver shown in dotted lines;

Fig. 21 is a view in elevation of the muzzle of the firearm;

35 Fig. 22 shows views in side elevation partly in section and front elevation, respectively of the muzzle piece;

Fig. 23 is a view in elevation of the front end of the stock with the ferrule in place thereon;

40 Fig. 24 is a plan view of the connecting rod catch;

Fig. 25 is a view in side elevation of the same;

45 Fig. 26 shows views in side and front elevation of the ejector;

Fig. 27 is a fragmentary view in side elevation, partly in section, of the butt of the stock;

50 Fig. 28 shows the cartridge guide in plan view, side and front elevations respectively;

Fig. 29 is a fragmentary plan view of the front end of the receiver;

55 Fig. 30 is a section taken on the line G—G of Fig. 20;

Fig. 31 is a view in rear elevation of the connecting rod; and

60 Fig. 32 is a fragmentary view in elevation of the inner face of the rear portion of the connecting rod.

Referring to the drawings by numerals of reference:

70 There is provided a stock 10 of suitable formation having, as usual, an aperture for the reception of the receiver and the guard

trigger group which clamps to the receiver and secures the parts operatively to the stock. The stock toward its forward end is engaged by the lower band 11 which carries the usual sling swivel 12.

The butt of the stock (see Fig. 27) may be provided with the usual plate 13 and adjacent the butt is secured the rear sling swivel which is preferably formed and secured in place as follows to provide a permanent and secure fastening. An aperture is formed in the stock to receive the plate or bar 14 on an end of which the swivel 15 is formed. The plate or bar 14 is drilled and tapped to receive the threaded end of a screw 16 which is threaded in from the butt of the stock. The forward end of the stock is preferably protected by a ferrule 13a, as seen most clearly in Fig. 23.

The guard trigger group (see Figs. 20, 3, 4 and 5) comprises the frame 17 angled at each end to enable it to be firmly wedged in the stock and formed with a stud 18 adapted to be seated in a recess 19 of the receiver to take end and lateral thrusts, and with a cross wall 20 which strengthens the structure, takes lateral thrusts and retains the working parts in gear when the guard group is disassembled from the firearm. The guard may be formed with a forwardly projecting portion 21 which forms a bottom for the magazine or chamber in which the cartridge clip is housed and on this portion are formed (see Fig. 9) lugs 22 and stud 23 to secure the clip ejecting spring 24 which spring has at its rear end lateral arms 25 and 26, the arm 25 being lower than the arm 26 to accommodate the spring to the unevenness in the sides of the clip.

Suitable supporting means are provided conveniently through an apertured lug 27 on the cross wall 20 and the side wall of the frame 17 for the support of various parts hereinafter to be set forth.

Mounted within the guard is a safety 28 carrying a stud 29 adapted to be received in an aperture in a wall of the guard, through which means the safety is pivoted. At its lower end the safety projects through an opening in the guard and adjacent to such projecting end it is provided with a slot 30 adapted to receive a latch bar 31 in such manner that when the safety is in the "on" or "safe" position the latch bar may move from the slot to permit the latch to swing to unlatched position, while, when the safety is in the "off" position, the bar may not move from the slot and the latch is locked.

The latch consists of a plate 32 (see Fig. 7) in which the bar 31 is secured, or with which it may be integral, bifurcated at its upper end to provide the arms 33 which are apertured to receive the ends of the latch pivot 34 which passes through the apertures of the lug 27 and the side wall, and these arms are offset adjacent to their upper ends, the offset portions bearing rollers 35 adapted to

engage shoulders 36 formed on the receiver. The guard is so formed that the upper surface adjacent to the rear and front ends will normally bear against the receiver leaving a clearance at the surface indicated at 37, so that when the latch is thrown to locking position, the clearance is taken up and the guard sprung firmly into place.

Also mounted on the latch pivot is a receiver shutter 38 which is adapted to cover an opening in the receiver uncovered by the bolt when in normal or breech closing position. The shutter is formed with an eccentric hub 39 on which is pivotally mounted a striker 40 formed with an angularly disposed bifurcated end having shoulders 41 to be engaged by the sear as will be hereinafter explained. The striker is cut away on that face adjacent to the safety to permit the passage of the striker past the lateral projection 42 on the safety when the safety is in "off" position and the projection in register with the path of travel of the cut away portion; when, however, the safety is thrown to the "on" position, the rear end of the projection 42 rides on the surface of the striker, retracting the striker slightly and holding it against firing movement.

A trigger 43 is pivotally mounted in the guard as at 44 and is preferably formed with an upwardly extending portion from the faces of which project the sear 45, and guides 46 so spaced from each other as to permit passage of the angled end of the striker when the trigger is swung to striker releasing position. The guide 46 also serves the purpose of holding the striker when the striker moves to cocked position before the trigger is released and guiding the striker into engagement with the sear.

Since it is highly desirable to have as few parts as possible in a firearm, a resilient element (see Figs. 18 and 19) is made use of as a trigger spring, striker spring, shutter actuating member and safety detent. This element preferably consists of a sleeve 47 having at its headed end apertured ears 48 which fit loosely on the trigger pivot pin 44 and which are in communication with a groove 49 to receive a lip 50 formed on the trigger. Housed in the sleeve is a compression spring 51, one end of which bears against the head of the plunger 52 on which head is formed a knob 53 seated in a depression of the striker 40. As will appear from a consideration of Figs. 2 and 3, the resilient element is constantly exerting a pressure on the trigger tending to hold it in normal position and likewise constantly pressing on the striker tending to swing it forwardly or into firing position. Since the striker is pivotally mounted on the eccentric hub of the receiver shutter, it follows that the pressure on the striker is conveyed through the striker to the eccentric

hub of the shutter in a manner tending to turn the shutter to the closed position.

The receiver 54 (see Fig. 20) is of any suitable form to properly house the parts operating therein or to receive the parts operatively connected therewith. In the present instance shoulders 36 are formed on the receiver in position to be engaged by the rollers 35 of the guard latch as heretofore explained. A guideway 55 is provided in one side of the receiver for the connecting rod as is shortly to be explained. Grooves 56 are formed in the inner side walls of the receiver to properly guide and position the cartridge clip, and a retaining member for the clip is provided in the form of a latch (see Figs. 9 and 16) pivotally secured to the receiver along its longitudinal axis as at 57 and having a recess adjacent to one end to receive a spring 58 which tends to rock the latch about its pivot to bring the laterally extending finger 59 into engagement with the clip and hold the clip in position. At this end the latch is preferably formed with a thumb piece 60 through which the latch may be manually rocked to release the clip. At its other end the latch is formed with a laterally projecting stud 61 which, as will be hereinafter explained, engages with an operative part of the mechanism so that the latch may be automatically rocked to clip latched and unlatched positions.

The bolt 62 (see Figs. 13, 14 and 15) is of irregular formation and has wings extending laterally therefrom, one of which slides on the guideway 63 of the receiver during reciprocation of the bolt. This wing is provided with lugs 64 adapted to take into notches 65 formed in the receiver for the purpose of aiding in locking the bolt in breech closing position. The wing on the other side has projecting therefrom a cam member 66 and this wing is formed to engage in a slot 67 in the receiver to likewise lock the bolt. The cam member 66 projects into a cam groove in the connecting rod for a purpose soon to be explained. An extractor 68 is positioned in a groove in the bolt in the well known manner and a resiliently actuated ejector 69 is housed in a recess in the bolt, preferably positioned diametrically opposite the extractor. A flattened portion 70 of the firing pin is engaged conveniently by a projection 71 of the extractor which forms a fulcrum for the extractor, prevents the firing pin from rotating and limits the reciprocating movement thereof. The firing pin is formed at its rear end with a laterally extending head 72 adapted to contact a projection 73 formed in the receiver when the bolt is in unlocked position so that the firing point is retracted into the bolt, but the head is cut away at 74 to pass such projection when the bolt is locked to permit the pin to be moved to its extreme forward or firing position. A recess 72a is

formed in the rear wall of the receiver to receive the head of the firing pin upon recoil of the bolt.

A barrel 75 is threaded or otherwise secured in the receiver and has preferably threaded to its muzzle end the forward portion 76 of the upper band 77, which is slotted to receive the front sight 78, the lower end of which sight preferably extends into a groove 79 cut longitudinally of the barrel so as to lock the upper band firmly in place on the barrel. This forward portion, when in position on the barrel, extends beyond the muzzle thereof, and into the extending portion is threaded a muzzle piece 80, the threads of which are interrupted by the grooves 81 which permits the piece to be locked in position by a screw head 82, cut away at one side to allow the muzzle piece to be rotated when such side is turned to face the muzzle piece.

The inner end of the muzzle piece is of slightly conical formation as indicated at 83 and terminates at the bore in a slight radius to form the annular projection 84, this formation being for the purpose of properly deflecting gases. The muzzle of the gun is countersunk at 85 for the same purpose and to form a seat for the end of the muzzle piece when it is desired to convert the arm from a semi-automatic to a hand operated arm.

The forward portion of the band is formed with a slot 86 opening into its interior and positioned between the muzzle of the barrel and the rear end of the muzzle piece, which slot is closed more or less by the adjustment of the muzzle piece to regulate the flow of gases to the working parts. The slot 86 opens into a cylinder 87 which forms a part of the upper band and extends longitudinally of the barrel, terminating at its rear end in the preferably integral rear element 88 of the upper band to which element is secured in the usual manner the stacking swivel 89. Projecting from the cylinder 87 is a stud 90 which is of suitable form to take a standard bayonet as is well understood.

Working in the cylinder 87, and forced rearwardly by the expanding gases admitted thereto, is a piston 91 secured to the forward end of a connecting rod 92, which rod is formed at its rear end with a laterally extending stud 93 adapted to ride in the guide groove 55 of the receiver. Adjacent to the rear end of the rod and projecting laterally from the outer face is an operating handle 94 through which the rod and bolt may be manually operated. A cam groove 95 is provided in the inner face of the rod adjacent to the rear end in position to receive the cam member 67 of the bolt. The forward wall of the cam groove is inclined to cam the bolt to unlocked position as the rod moves rearwardly while the rear wall of the groove cooperates with the rear face of the cam to rock the bolt toward locked position as the rod

moves forwardly toward normal position. As will be seen most clearly in Figs. 3 and 4, the rear portion of the connecting rod is offset from the main portion which latter portion is of tubular formation to house a spring 96, the forward end of which rests against the piston 97 suitably secured in the forward end of the rod and the rear end of which contacts the forward end of a follower actuating rod 98 which extends through a slot formed in the bottom of the tubular portion of the connecting rod.

The follower actuating rod 78 is urged rearwardly by the spring 98 to move the follower and deliver cartridges from the clip through the following mechanism. The rear end of the rod 98 is forked to embrace a stud 99 projecting laterally from the lower end of the follower upper lever, which lever may be conveniently formed with a laterally extending pin 100 through which the lever may be pivotally mounted in apertures formed in spaced ears 101 depending from the forward end of the receiver. An arm 102 extends rearwardly from the lever and has a laterally extending stud 103 at its rear end adapted to enter an aperture 104 formed in the follower 105. Extending upwardly from the lever may be a pointer 106 for the purpose of indicating the number of rounds in the magazine by registering with a scale 107 provided at the side of the receiver.

The follower lower lever has a stud 108 projecting laterally from one end thereof to enter an aperture 109 in the follower. The other end of this lever is bifurcated to provide spaced arms having adjacent their free ends the trunnions 110 which are adapted to be sprung into apertures 111, provided in the spaced ears depending from the forward end of the receiver. At these same ends the arms are cut away on a reduced radius to provide the teeth 112 which cooperate with teeth 113—113, formed on a connecting rod catch for the purpose of operating the same to engaged and disengaged positions.

The connecting rod catch is pivotally mounted on the pin 100 and is provided at its rear end with an aperture 114 to receive the stud 61, extending from the forward end of the clip latch. It will be apparent that, as the follower is forced upwardly by the spring, the rear teeth 112 will approach the teeth 113 and, when the follower has reached its uppermost position these teeth will contact, throwing the catch to engage the lip 115 on the connecting rod. When the catch has been thrown to this position the upper wall of the aperture 114 will contact the top of the stud 61 depressing the same and rocking the clip latch on its pivot to release the clip which will then be immediately ejected by the clip ejecting spring 24.

Also mounted on the pin 100 is a cartridge guide 116 which may be formed with a stud

117 to enter an aperture 118 formed in the receiver and with a foot portion 119 adapted to rest on the forward edge of the guard.

5 A perforated protector 119 may be provided to protect the hand from the hot barrel, conveniently held in place by having its rear edge seated in a groove in the front of the receiver and its front edge engaged under the upper band.

10 The receiver may be formed to receive the rear sight 120.

The operation of the firearm is as follows:

To operate as a hand-operated arm, the muzzle piece is screwed in to seat against the muzzle of the barrel, thus cutting off entry of gas to the cylinder and piston. The bolt may then be retracted manually through the bolt handle.

To operate semi-automatically, the muzzle piece is screwed out away from the muzzle of the barrel to allow a desired amount of gas to enter the cylinder and act on the piston.

15 A clip containing cartridges is inserted in the magazine, being held in place therein by the clip latch. This action depresses the follower, rocks the connecting rod catch to free the clip latch and connecting rod, and also moves the indicator to register full magazine. Insertion of the clip releases the bolt which moves forward, inserting a cartridge in the chamber and leaving the arm in a position to be fired.

20 Upon firing the bolt remains locked until the bullet has passed from the barrel, allowing the gases of explosion to enter the cylinder and force the piston and connecting rod rearwardly. Rearward movement of the connecting rod cams the bolt to unlocked position and at the same time cams the firing pin to safe position, then carries the bolt rearwardly allowing the extractor to extract the empty shell which is then ejected by the ejector.

25 Movement of the piston, connecting rod and bolt rearwardly, compresses the spring housed in the connecting rod, thereby assuring sufficient pressure on the follower rod to actuate the follower to force a cartridge from the clip into the path of the bolt on its forward movement which movement is caused by the expansion of the aforesaid spring.

I claim:

1. The combination with a gun stock, of a guard, a receiver, a latch carried by one of said elements and means on the other of said elements adapted to be engaged by said latch to secure the stock, guard and receiver in assembled relation.

2. The combination with a gun stock, of a guard, a receiver, a latch carried by one of said elements, rollers on the latch, and shoulders on the other of said elements contacted by the rollers to secure the parts in assembled relation.

3. The combination with a gun stock, of a

guard, a receiver, a latch carried by one of said elements, means on the other of said elements to be engaged by the latch to secure the parts in assembled relation, a safety, and means on the safety engageable with the latch to retain the latch in latched position while the safety is in the "off" position.

4. The combination with a gun stock, of a guard, a receiver, a latch carried by one of said elements to be engaged by the latch to secure the parts in assembled relation, a safety provided with a slot, and means on the latch engageable in the slot to retain the latch in latched position while the safety is in the "off" position.

5. The combination with a gun provided with a receiver, of a bolt reciprocable in the receiver, a firing pin reciprocable in the bolt, a laterally extending head for the pin, and means in the receiver to engage the head on rocking of the bolt to unlocked position to retract the pin.

6. The combination with a gun provided with a receiver, of a bolt reciprocable in the receiver, a firing pin in the bolt, an extractor carried by the bolt, and means on the extractor to prevent rotation of the pin with respect to the bolt.

7. The combination with a gun provided with a receiver, of a bolt reciprocable in the receiver, a firing pin in the bolt, an extractor carried by the bolt and means on the extractor cooperating with the pin to limit movement thereof.

8. The combination with a gun provided with a receiver, of a bolt reciprocable in the receiver, a firing pin in the bolt, an extractor carried by the bolt and means on the extractor to limit reciprocatory movement of the pin with respect to the bolt and prevent rotary movement thereof with respect thereto.

9. The combination in a gun, embodying a cartridge magazine, of a follower for forcing cartridges from the magazine, a resiliently held bolt operating reciprocable element on the gun, and a connection between the follower and the resilient portion of said element.

10. The combination in a gun having automatic feed, of a follower, links connecting the follower to the gun, a resiliently held reciprocable element on the gun, and a connection between the links and the resilient member of said element.

11. The combination in a gun having automatic feed, of a follower, links connecting the follower to the gun, a reciprocable element carried by the gun, a resilient member normally holding said element, a connection between the resilient member and the links, a catch carried by the gun for latching the reciprocable member against movement when the follower is in its uppermost position, and

cooperating means on the catch and links for actuating said catch.

12. The combination with a gun, of a cartridge clip, means for latching the clip in place in the gun, a follower, means for actuating the follower to force cartridges from the clip, and means actuated by the follower actuating means when the clip is empty to unlatch the clip.
13. The combination with a gun, including a magazine, of a clip for insertion in the magazine, means for latching the clip in place, a follower, means for actuating the follower to force cartridges from the clip, means actuated by actuation of the follower when the clip is empty to unlatch the clip, and a resilient element secured to the bottom of the magazine for automatically expelling the clip when unlatched.
14. The combination in a gun, of a trigger, a hammer controlled by said trigger, a receiver shutter and a resilient element to actuate the hammer and receiver shutter, and hold the trigger in normal position.
15. The combination in a gun, of a trigger, a hammer controlled by said trigger, a receiver shutter, a safety, and a resilient element to actuate the hammer and receiver shutter, to hold the trigger in normal position and to detain the safety when in "on position".
16. The combination in a gun, of a trigger, a receiver shutter pivotally mounted in the gun, an eccentric lug on the shutter, a hammer controlled by the trigger pivotally mounted on the lug, and a resilient element interposed between the trigger and hammer, for actuating the hammer and receiver shutter, and retaining the trigger in normal position.
17. The combination with a firearm provided with a receiver and a magazine for receiving a cartridge clip of a latch pivoted along its longitudinal axis to the receiver, a thumb piece on the latch for manual operation thereof, a projection on the latch extending into the receiver to engage the clip, and a stud on the latch to be engaged by a movable element of the firearm to automatically operate the latch.
18. The combination with a gun of the gas operated type provided with a gas cylinder, of a piston working in the cylinder, an operating rod engaged by the piston, an operating spring guided by the rod, a connection between the rod and operative parts of the gun, and a follower rod engaged by the spring, and through pressure imparted to the spring operating other parts of the gun.
19. The combination with a gas operated gun provided with a gas cylinder, a breech bolt, a follower, an operating rod catch, an indicator and a clip latch, of a piston working in the cylinder, an operating rod engaged by the piston and connected to the breech bolt, a spring guided by the operating rod, a follower rod engaged by the spring and having operative connection with the follower, operating rod catch, indicator, and clip latch.
20. The combination with a gun of the gas operated type; of an upper band embodying a gas cylinder, a sight base and a muzzle gland receiving opening; and a muzzle gland secured in said opening to regulate the flow of gas to the cylinder.
21. The combination with a gun of the gas operated type; of an upper band embodying a gas cylinder, a sight base and a muzzle gland receiving opening; and a muzzle gland adjustably secured in said opening to regulate the flow of gas to the cylinder.
22. The combination with a gun of the gas operated type; of an upper band embodying a gas cylinder, a sight base and a muzzle gland receiving opening; a muzzle gland adjustably secured in said opening to regulate the flow of gas to the cylinder, and means for locking the gland in adjusted positions.
23. In a rifle, in combination, a receiver, a trigger guard, abutting surfaces on the guard and receiver establishing a clearance between other surfaces of the guard and receiver, and a latch carried by one of said elements and cooperating with means on the other to take up said clearance and spring the receiver and guard together.
24. In a rifle, in combination, a receiver, a trigger guard frame, means for detachably securing said guard frame to said receiver comprising pin and socket engagement between the receiver and the rear end of said guard frame, a pin and socket connection between the receiver and the forward end of said guard frame, and a latch connection between said receiver and an intermediate portion of said guard frame.

JOHN C. GARAND.

110

115

120

125

130