

A. BUSSE.  
METAL FRAME FOR GLASS PANES.  
APPLICATION FILED AUG. 10, 1910.

1,001,502.

Patented Aug. 22, 1911.

FIG. 1.

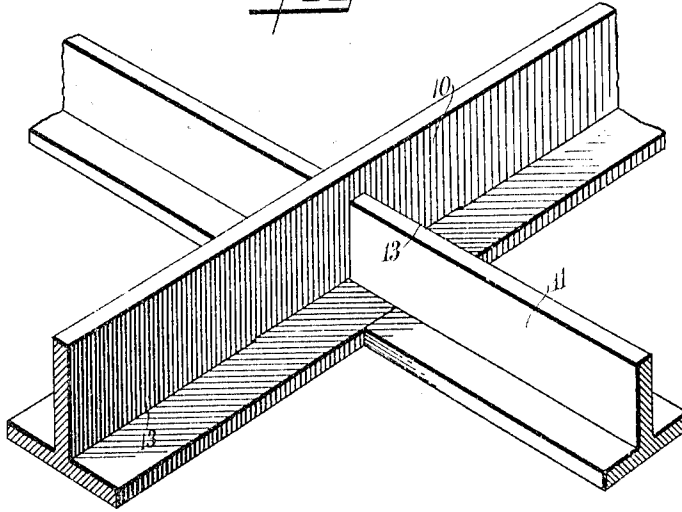

FIG. 2.

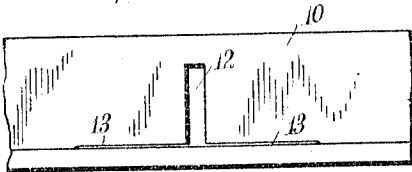

FIG. 3.

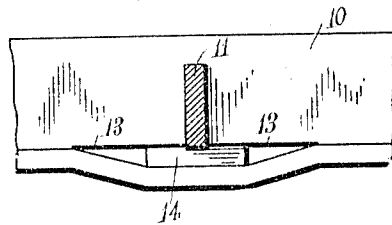

FIG. 4.

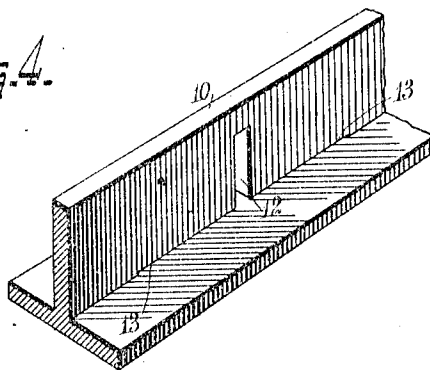
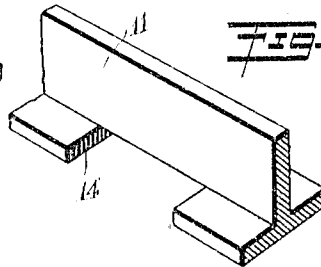

FIG. 5.



WITNESSES:  
G. Robert Thomas  
W. W. Holt

INVENTOR  
Amand Busse  
BY *Munn & Co*  
ATTORNEYS

# UNITED STATES PATENT OFFICE.

AMAND BUSSE, OF NEW YORK, N. Y.

METAL FRAME FOR GLASS PANES.

1,001,502.

Specification of Letters Patent. Patented Aug. 22, 1911.

Application filed August 10, 1910. Serial No. 576,502.

*To all whom it may concern:*

Be it known that I, AMAND BUSSE, a citizen of the United States, and a resident of the city of New York, borough of Manhattan, in the county and State of New York, have invented a new and Improved Metal Frame for Glass Panes, of which the following is a full, clear, and exact description.

10 The invention is an improved metal frame for glass panes of the character disclosed in Letters Patent Number 942,611, granted to me December 7, 1909, wherein the frame comprises intersecting mullion and transom bars, each bar having a head and a web, and one of the bars at the point of intersection having a slot in the web thereof through which the other bar is adapted to be slid when both of the bars are facing in the same direction; and the other bar having its head cut out at the point of intersection to receive the head of the slotted bar and thus locate the heads of both bars in the same plane.

15 The object of the present invention is to so join the bars that no unfilled openings or protuberances will be presented at the points of intersection in the finished frame, producing an interlocked frame structure of relatively high strength.

20 Reference is to be had to the accompanying drawings forming a part of this specification, in which similar characters of reference indicate corresponding parts in all the views.

25 Figure 1 is a perspective view of a portion of a metal frame constructed in accordance with my invention; Fig. 2 is a plan of one of the bars; Fig. 3 is a fragmentary sectional view of the frame, showing the bars relatively disposed preparatory to pressing in the head of one of the bars and locking them together at the joint; Fig. 4 is a perspective view of the bar shown in Fig. 2; and Fig. 5 is a similar view of the other intersecting bar.

30 The frame embodies in its construction a number of mullion bars 10 and a number of transom bars 11, the bars intersecting and each continuous in length. Each bar is of metal, ordinarily of rolled steel, and, as shown, is T-shape in cross-section, the particular form, however, being immaterial so long as the bar is provided with a head and a web.

35 In joining the bars together at the point of intersection in accordance with my inven-

tion, I provide the web of one of the bars (shown to be the mullion bar 10) with a transverse slot 12, extending to the bar head and of a length approximately equal to the width of the web of the bar 11. At each side of the slot 12, the web of the bar 10 is slit from the head of the bar a distance slightly greater than the width of the head of the bar 11, as indicated at 13, the construction of the bar 10 being then as shown in Fig. 2. The head of the bar 10 after being slit from the web is pressed out to form a slot of sufficient extent to receive the head of the bar 11, as shown in Fig. 3.

40 The head of the bar 11 at the point where the bar is to intersect the bar 10, is transversely cut out or otherwise removed, forming the recess 14, this recess being approximately equal to the width of the head of the bar 10.

45 In assembling the bars, the bar 11 is passed through the bar 10, as shown in Fig. 3, until the recess 14 is brought into register with the expanded or pressed-out portion of the head; the web of the bar 11 being received in the slot 12, and the head of this bar received in the slot afforded by expanding or pressing out the head of the other bar. With the bars in this position, as illustrated in Fig. 2, the pressed-out portion of the head of the bar 10 is forced to the web and into the recess 14, securely locking the two intersecting bars together. With the bars thus joined, no openings or recesses which are made in one bar to receive the other are left unfilled, nor is the head of one bar left protuberant for the reception of the head of the other bar, but the heads of the bars are presented in the same plane, whereby the glass panes will lie flat against the inner faces of the flanges or heads of the bars, and the frame structure will present a smooth, unbroken appearance.

50 Having thus described my invention, I claim as new and desire to secure by Letters Patent:

1. The combination of a mullion bar and a transom bar intersecting each other, each bar having a head and a web, with one of the bars having its head removed at the point of intersection to receive the head of the other bar, and the said other bar having a slot in the web thereof through which the web of the first bar passes, and having the head thereof slit from the web at the slot and pressed into the recess formed by the

removed portion of the head of the said first bar.

2. In an intersecting framework, a T-shaped bar having a continuous head, a  
5 transverse recess in the web of said bar, extending to the head thereof, said web slitted on opposite sides of the recess adjacent said head, and an intersecting T-shaped bar, the web of which passes through  
10 said recess and the head of which is recessed,

whereby the heads of the two members are adapted to lie in the same plane.

In testimony whereof I have signed my name to this specification in the presence of two subscribing witnesses.

AMAND BUSSE.

Witnesses:

W. W. HOLT,  
JOHN P. DAVIS.