

(Model.)

W. B. WALDRON & G. C. BOLLER.

SEAL LOCK.

No. 379,348.

Patented Mar. 13, 1888.

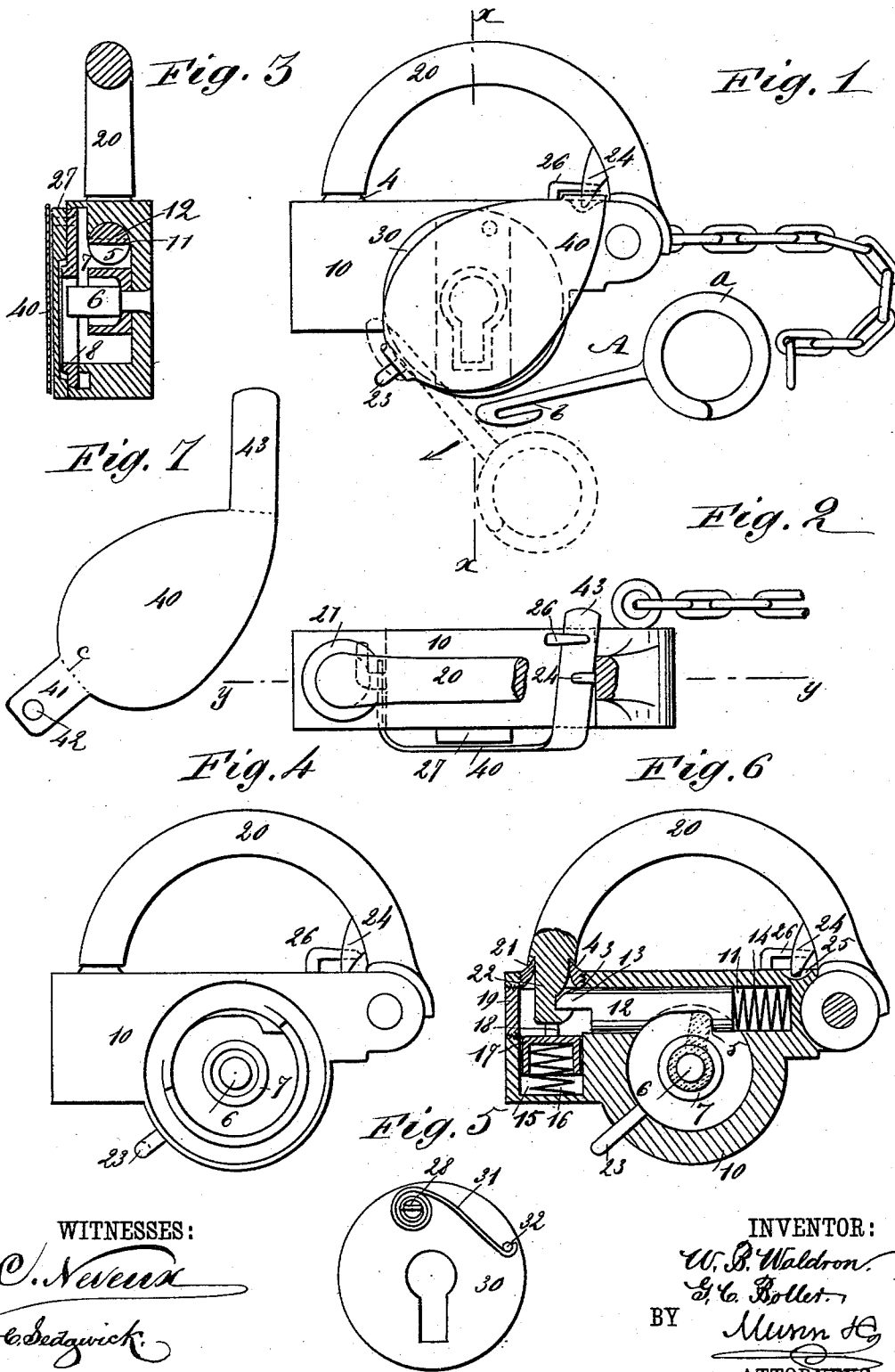

WITNESSES:

C. Newell
C. Sedgwick

INVENTOR:

W. B. Waldron
G. C. Boller
BY *Munn & Co*
ATTORNEYS.

UNITED STATES PATENT OFFICE.

WARREN BICKFORD WALDRON AND GEORGE CARL BOLLER, OF FOLSOM CITY, CALIFORNIA.

SEAL-LOCK.

SPECIFICATION forming part of Letters Patent No. 379,348, dated March 13, 1888.

Application filed July 6, 1887. Serial No. 243,503. (Model.)

To all whom it may concern:

Be it known that we, WARREN BICKFORD WALDRON and GEORGE CARL BOLLER, of Folsom City, in the county of Sacramento and State of California, have invented a new and Improved Seal-Lock, of which the following is a full, clear, and exact description.

The object of our invention is to provide a lock which may be used as an ordinary pad-lock, but which is more especially designed as a seal-lock for use on freight-cars while they are in transit, the parts being so arranged that the lock cannot be opened or tampered with without first breaking or otherwise injuring the seal.

Reference is to be had to the accompanying drawings, forming a part of this specification, in which similar figures of reference indicate corresponding parts in all the views.

Figure 1 is a side view of our improved form of lock, the seal being represented as it appears when in position and secured to the lock-case. Fig. 2 is a plan view of the lock, a portion of the shackle being broken away. Fig. 3 is a cross-sectional view taken on line *x x* of Fig. 1. Fig. 4 is a view of the lock with the escutcheon removed. Fig. 5 is a view of the inner face of the escutcheon. Fig. 6 is a central longitudinal sectional view, the view being taken on line *y y* of Fig. 2; and Fig. 7 is a view of one of the seal-blanks.

In the drawings, 10 represents the lock-case, in the upper portion of which there is formed a longitudinal groove, 11, in which there is mounted a locking-bolt, 12, that is formed with a forwardly-extending nose, 13, the upper face of which is rounded off, as shown at 3, the bolt being normally forced forward by a spring, 14, that is housed within the inner end of the groove 11.

In advance of the groove 11 there is a vertical groove, 15, in which there is arranged a spring, 16, that carries a cap, 17, the upper face of the cap being provided with a pin, 18, which acts as a stop and prevents the spring 14 from forcing the bolt 12 too far forward.

The bow or shackle 20 is hinged to the lock-case, and enters the vertical groove 15 through a bushing, 21, that is fixed in the upper plate of the lock-case, this bushing being formed with

an upwardly-extending ridge, 4, which enters an undercut groove that is formed just above the hook 22 of the shackle 20, this arrangement being provided in order that snow, hail, &c., will be kept out of the inside of the lock-case. In introducing the bolt 12 it is passed in through the forward open end of the groove 11, which end is subsequently closed by a plug, 19. The bolt 12 has a shoulder, 5, in order that it may be engaged by the bit of the key, which key should be formed to fit over the key-post 6 and a barrel, 7, which surrounds said post.

To the under face of the lock-case there is secured a prong, 23, while a similar prong, 24, is carried by the shackle 20, the point of this prong 24 being arranged to enter a recess or depression, 25, that is formed in the upper face of the lock-case, and beyond this recess there is a keeper, 26, which extends across a portion of the upper face of the lock-case.

The key-hole opening in the escutcheon is closed by a plate, 27, which is carried by a pin, 28, that extends through an aperture in the lock-casing or its escutcheon 30. The inner end of the pin is provided with a notch which receives the inner end of the coiled spring 31, the opposite end of the spring being connected to the casing by means of the pin 32 on the inner face of the escutcheon. By this construction if the plate 27 is swung from over the key-hole the pin 28 will be rotated and the spring wound thereon after the manner of a clock-spring on its arbor. The unwinding or expanding of the spring will return the plate to its proper position over the key-hole. A ridge, 8, is formed about the key-hole and a recess is formed upon the inner face of the plate, in order that said plate may pass over this ridge, this construction being adopted to prevent the entrance of rain or snow through the key-hole.

In connection with the lock described we employ a sealing-plate, 40, of the form illustrated in Fig. 7, said plate being provided with a short tongue, 41, that has an aperture, 42, and with a longer tongue, 43, which is not apertured.

From the construction described it will be seen that if the key is turned so that the bolt

12 will be forced back against the action of the spring 14 the spring 16 will act to throw the hook and shackle out of the lock-case; but it will also be seen that if the pressure upon the bolt is relaxed and the hook of the shackle forced inward said hook will be automatically engaged by the bolt.

In order to apply the seal, the key is removed from the lock and the tongue 41 is brought into engagement with the prong 23, said prong being passed through the aperture 42 of the tongue. The seal-blank is then bent up across the face of the escutcheon, the tongue 43 being carried over the upper face of the lock-case above the recess 25 and beneath the prong 24, the extreme end of the tongue being passed under the keeper 26. Then the shackle is forced downward and its prong 24 will indent that portion of the tongue 43 which is above the recess 25, and after the bolt has once engaged with the hook of the shackle it will be impossible to open the lock without breaking or defacing the seal.

It will be noticed that the tongue 43 extends from the body of the seal at an obtuse angle to the tongue 41, in order that it may be bent over in the path of the prong 24, and yet allow the body of the seal to lie flat upon the lock.

In order that the seal may be broken, we provide an opening attachment such as that shown at A, said opening attachment consisting of a hooked arm, *b*, which is adapted to enter the space between the escutcheon and the lower portion of the main body of the seal, as indicated by dotted lines in Fig. 1. Then if the opening attachment be moved forward and upward the seal will be broken upon a line corresponding with the dotted line shown at *c* in Fig. 7. At the other end of this opening attachment there is a split ring, *a*, upon which the key of the lock may be placed.

Having thus fully described our invention, we claim as new and desire to secure by Letters Patent—

1. The combination, with a lock-case formed with a horizontal groove and a vertical groove, of a bolt mounted in the horizontal groove, a spring arranged in connection with the bolt, a cap carrying a stop, a spring arranged beneath the cap, the cap and spring being mounted in the vertical groove, and a shackle having a hooked point adapted to enter the vertical groove, substantially as described.

2. The combination, with a lock-case, of an escutcheon formed with a ridge, 8, and a key-hole plate formed with a recess adapted to receive said ridge, whereby the key-hole is closed against the entrance of rain, snow, &c., substantially as described.

3. A lock-case formed with a prong, 23, in combination with a shackle formed with a prong, 24, a recess being formed in the lock-case in position to receive the point of the prong 24, substantially as described.

4. A lock-case provided with a prong, 23, a recess, 25, and a keeper, 26, in combination with a shackle that is provided with a prong, 24, substantially as described.

5. A seal for locks of the character described, consisting, essentially, of a blank provided with tongues 41 and 43 at its opposite ends, the tongue 41 being provided with an aperture, 42, and the tongue 43 projecting from the body at an obtuse angle to the tongue 41, substantially as described.

WARREN BICKFORD WALDRON.
GEORGE CARL BOLLER.

Witnesses:

FREDERICK PARKER BURNHAM,
EDWARD R. LEVY.