

[72] Inventors **Hoyne S. Greenberg**  
**Beverly Hills, Calif.;**  
**Max L. Wexler, Chicago, Ill.**  
 [21] Appl. No. **864,732**  
 [22] Filed **Oct. 8, 1969**  
 [45] Patented **June 29, 1971**  
 [73] Assignee **Hoyne Industries, Inc.**  
**Los Angeles, Calif.**

2,030,135	2/1936	Carpenter .....	206/DIG. 18
2,585,924	2/1952	Freedman et al. ....	206/46 AM
2,881,546	4/1959	Gauthier .....	35/26
2,896,351	7/1959	Johnson .....	206/DIG. 18
2,956,703	10/1960	Royal .....	156/71
3,433,485	3/1969	Renn et al. ....	35/26
3,466,217	9/1969	Mott .....	206/DIG. 18
3,495,701	2/1970	Chandos .....	206/47

*Primary Examiner*—William T. Dixon, Jr.  
*Attorney*—Wallenstein, Spangenberg, Hattis & Strampel

[54] **KIT FOR MAKING A PICTURE-DISPLAYING MURAL**  
**6 Claims, 8 Drawing Figs.**

[52] U.S. Cl. .... **206/47 R,**  
 35/26, 206/DIG. 18  
 [51] Int. Cl. .... **B65d 79/00,**  
 B44f 1/00  
 [50] Field of Search..... 206/1.7, 46  
 AM, 47, DIG. 18; 161/6; 156/71; 35/26  
 [56] **References Cited**  
**UNITED STATES PATENTS**  
 1,259,787 3/1918 Segall ..... 206/DIG. 18

**ABSTRACT:** A do-it-yourself kit including a series of individual transparent plates with opposite parallel sides and each of a size constituting a small fraction of the overall mural to be fabricated therefrom. Each of the plates has deposited on the rear surface and in only selected areas thereof a pigmented material forming a different fractional part of an overall picture formed by the juxtaposed positioning of the plates in two directions. A mirror-forming coating is formed over the deposited pigmented material which coating forms a mirrored surface between the areas of each plate covered by the pigmented material.

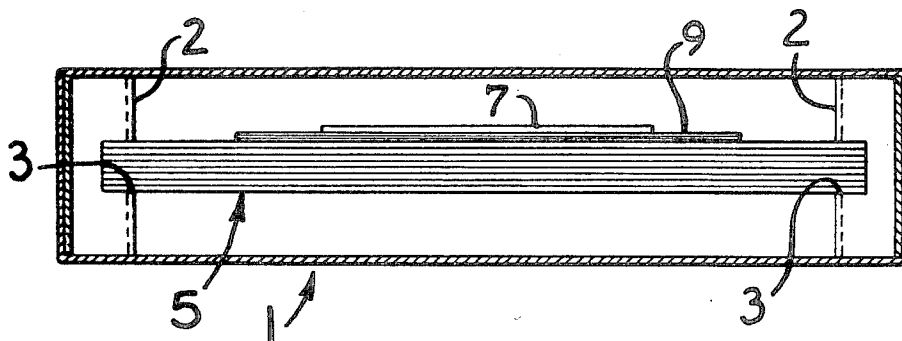

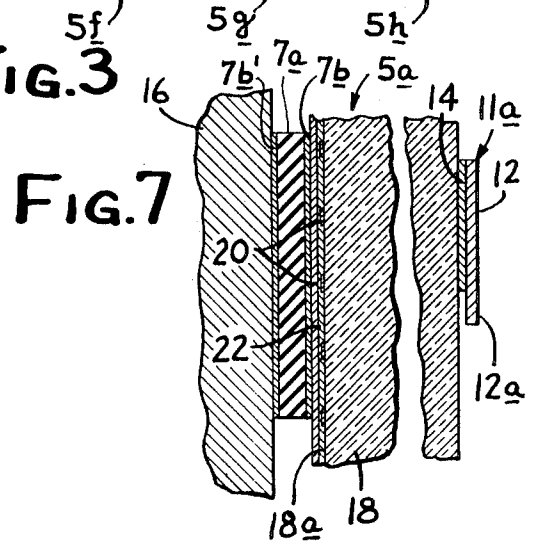
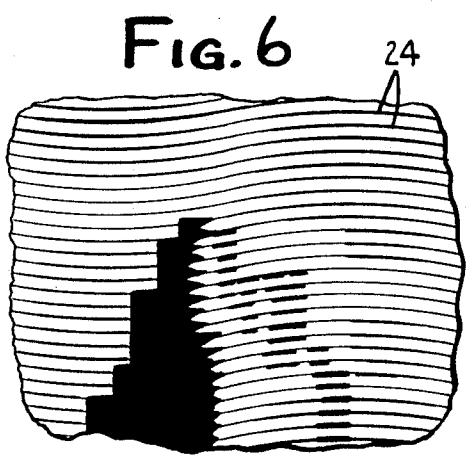
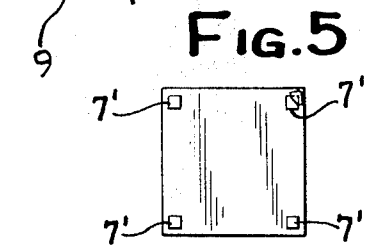
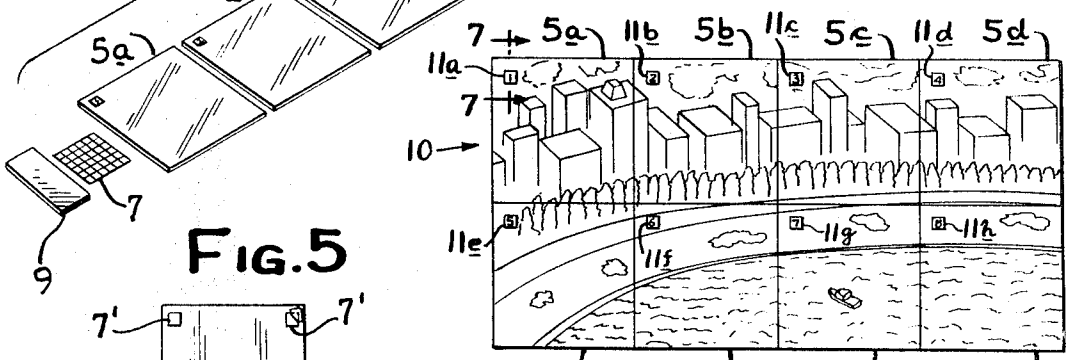
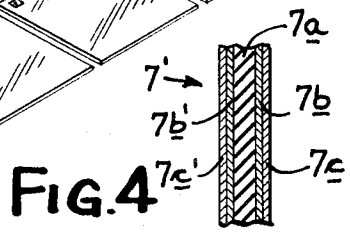
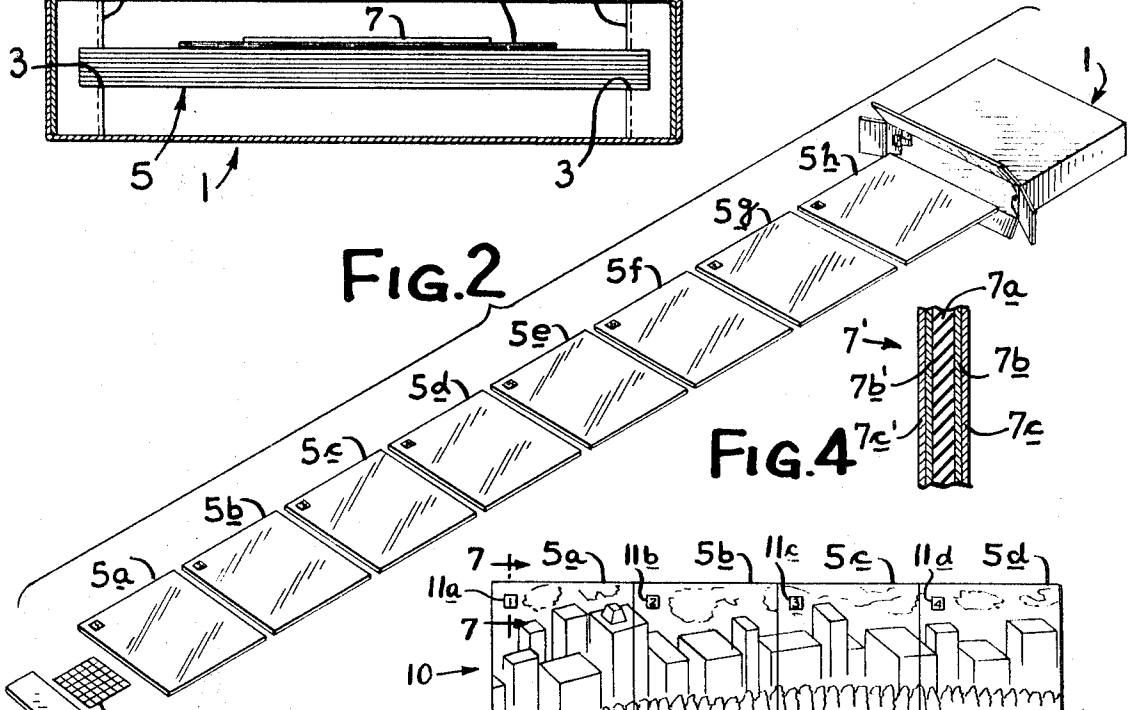
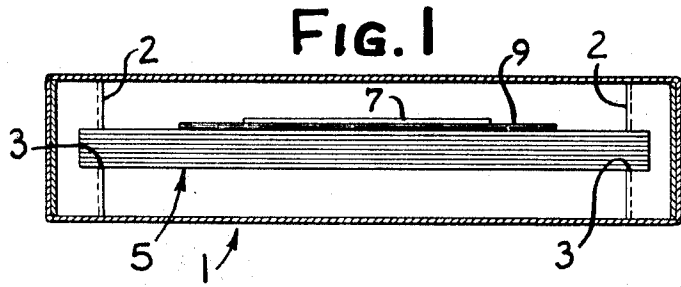

**INVENTORS**  
**HOYNE S. GREENBERG**  
**MAX L. WEXLER**  
*by: Wallenstein, Spangenberg, Hattis*  
*+ Strampel* **ATTYS.**

FIG. 8

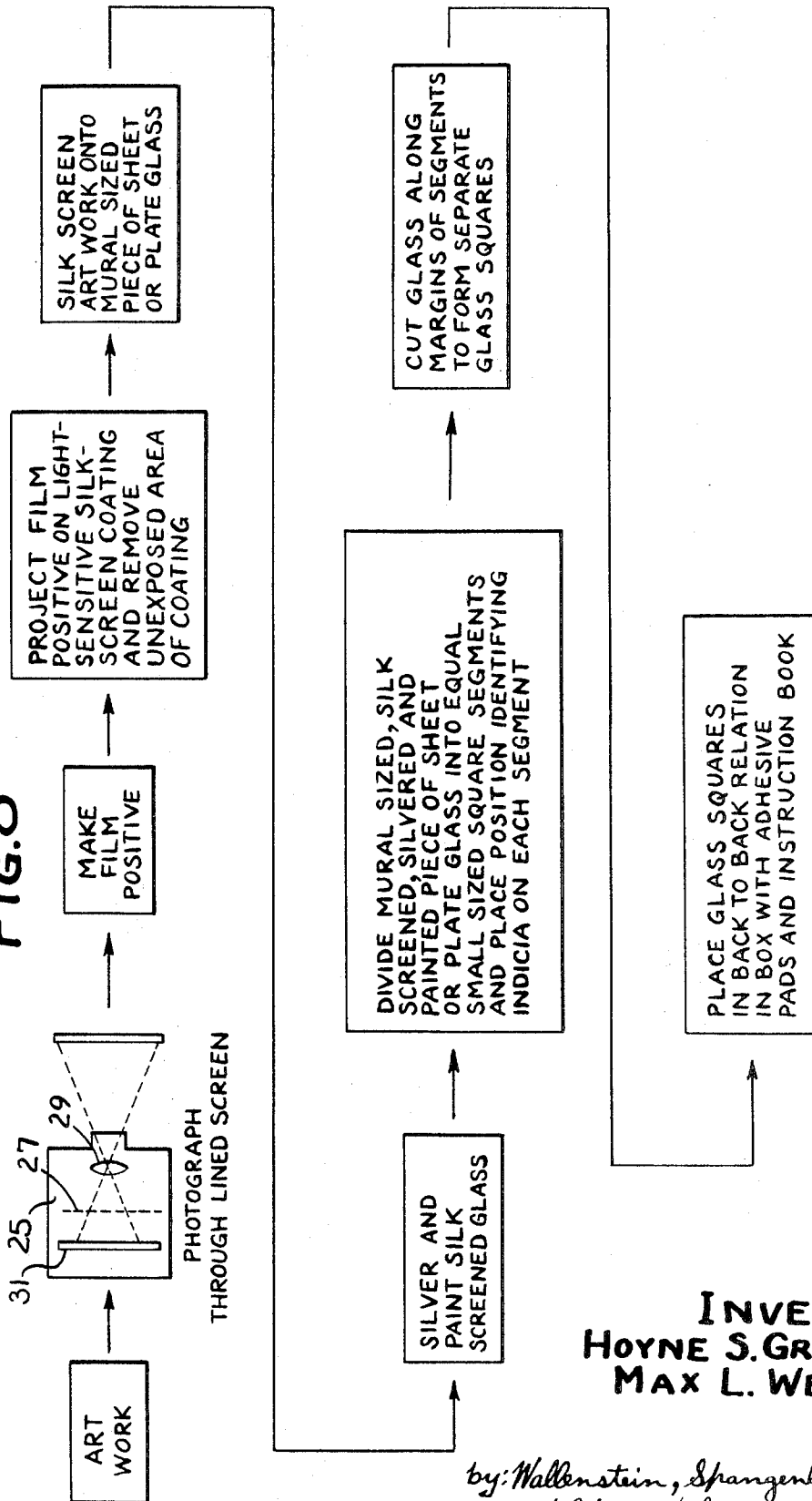

**INVENTORS**  
**HOYNE S. GREENBERG**  
**MAX L. WEXLER**

*by: Wallenstein, Spangenberg, Mattis & Strampel*  
**ATTYS.**

### KIT FOR MAKING A PICTURE-DISPLAYING MURAL

The present invention relates to the decoration of walls with artwork and the like. More particularly, the present relates to a wall mounted plate providing a unique wall mountable mural, to a kit comprising a number of such plates and other components for readily fabricating such a mural of much greater size than that of one plate upon a wall surface, and to a process for fabricating such plates.

The present invention provides a very unusual and attractive wall decoration which blends a mirror and a mural as a totally new concept in wall decoration.

In the most advantageous form of the invention, a do-it-yourself kit is provided from which such a relatively large combination mirror and mural can be constructed quickly and easily and at a surprisingly low cost. The kit includes a series of individual glass or glasslike plates, which may most desirably be squares of sheet or plate glass, each of a size constituting a small fraction of the overall mural to be fabricated therefrom. Each of the plates has deposited on the rear surface thereof and in only selected areas thereof a pigmented material forming a different fractional part of an overall scene formed by the juxtapositioning of the plates in two directions. A mirror-forming coating is applied over the deposited pigmented material which coating forms a mirrored surface between the areas of each plate covered by the pigmented material.

Each of the plates is most advantageously provided with a removable indicia on the front surface thereof which identifies the particular position of the plate involved in the completed mural. Also, the kit is provided with at least two and preferably four adhesive pads for each plate, each pad being much smaller than the associated plate and having layers of pressure-sensitive adhesive on opposite sides thereof, one of which is operable to secure the pad to the rear of the plate involved and the other of which is operable to secure the plate to a wall surface.

When the individual plates are properly positioned and adhesively secured to a wall surface, a very strikingly unique wall decoration results in which the mirrored background of the scene which appears inlaid within the mirror reflects not only the subject of the scene involved but also the surrounding room.

A specific aspect of the invention is the manner in which the scene is produced on the rear surface of each of the plates. The process of applying a mirror-forming backing over the deposits of pigmented material thereon involves the use of chemicals which can readily attack the pigmented material. If these pigmented materials are applied as separate small dots, the density of which varies with the shading or darkness of the portion of the scene involved as in the case of conventional picture reproducing techniques, each dot provides exposed edges all around the same subject to undercutting by the mirror-forming chemicals, and so the chemicals readily attack and strip the small dots of pigmented material to destroy the scene involved. It has been discovered that this problem can be alleviated by the production of the scene on the rear surface of each plate in the form of spaced lines of pigmented material, the width of which lines varies to produce the gradation of shading or darkness in the portion of the picture involved. A line of pigmented material, as distinguished from a number of small dots over the same area, provides only a very limited amount of exposed edges subject to undercutting by the mirror-forming chemicals and the integrity of the much larger mass of pigmented material holds the material together upon the plate surface even when the edges of the material are undercut by the chemicals.

Another aspect of the invention to be described deals with a process of making the mirror-mural forming plates.

The above and other features and advantages of the invention will become apparent upon making reference to the specification to follow and the drawings wherein:

FIG. 1 is a sectional view of the do-it-yourself kit of the present invention, packaged in a box for sale to the ultimate user;

FIG. 2 is an exploded view of the contents of the box shown in FIG. 1;

FIG. 3 is a view of the combination mirror-mural fabricated from the components shown in FIG. 2;

FIG. 4 is a sectional view through one of the adhesive pads forming part of the kit of FIGS. 1 and 2 and used to secure a plate thereof to a wall surface;

FIG. 5 is a rear view of one of the plates forming the combination mirror and mural in FIG. 3;

FIG. 6 is a greatly enlarged fragmentary view of one of the plates shown in FIG. 3, showing the manner in which a scene is produced thereby by deposition of pigmented material on the rear surface of each plate in spaced lines with the thickness of each line determining the shading of the portion of the picture involved;

FIG. 7 is a greatly enlarged sectional view through a portion of one of the plates in FIG. 3, showing the manner in which each plate is secured to a wall surface; and

FIG. 8 is a flow diagram illustrating the process for making the mirror-mural forming plates shown in FIGS. 1 and 2.

Referring now more particularly to FIG. 1, the kit there shown comprises a box 1 made of cardboard or the like having folded cardboard inserts 2-2 which are slotted at 3-3 to form openings having resilient margins for frictionally receiving and holding a set of mirror-mural forming plates 5 to be described stacked together to form a compact integral assembly of such plates. The kit further includes an integral assembly 7 of adhesive pads 7'. The pads 7' loosely are attached to one another so that they can be easily manually pulled from the adjacent pads. Each of the adhesive pads includes a main body portion 7a coated on opposite sides with layers 7b and 7b' (FIG. 4) of pressure-sensitive adhesive. The adhesive layers 7b and 7b' are respectively overlaid by backing layers of paper 7c and 7c' or the like having a release coating on the inner faces thereof to permit the paper readily to be pulled from the associated adhesive layers. The backing layers 7c and 7c' are peeled from the pad to expose the associated pressure-sensitive layers, one of which is applied to the back of one of the plates 5 involved and the other of which is applied to a wall surface involved to aid in securing the plate involved thereto.

The kit also includes an instruction booklet 9 which explains the manner in which the individual pads 7' and plates 5 are assembled to form the combination mirror-mural 10 shown in FIG. 3 which is two plates high and four plates wide. (A lesser number of plates could be provided, for example six to make a combination mirror-mural three plates wide by two plates high.) The various plates 5 illustrated, which are individually identified by reference numerals 5a, 5b, 5c, 5d, etc., are provided with removable indicia 11a, 11b, 11c, 11d, etc., most advantageously applied to the front surface of each of the plates which identifies the particular position of each plate in each mural for the involved. This indicia, for example, may comprise a small piece of paper 12 (FIG. 7) on the front face of which is printed a number or the like identifying the position of the plate in the combination mirror-mural 10. A layer 14 of pressure-sensitive adhesive material is applied to the back of the paper which adhesive material terminates short of one of the edges thereof 12 so that an adhesive tab 12a is left which enables a person readily to pull the sheet of indicia from the front of the plate involved.

The plates 5 are fabricated most advantageously in a manner to be described so each forms only a small portion of an overall scene to be displayed, so that when the various plates are placed in juxtaposed relation as shown in FIG. 3 an overall integrated scene with a mirror background results. The outlines of various buildings or other scenery elements of adjacent plates run together to form an integrated scene, and one looking at the combination mirror-mural 10 loses sight of the fact that the overall scene is broken into individual segments by the individual plates.

3

As shown in FIG. 5, each of the plates 5a, 5b, 5c, 5d, etc., is attached to a wall surface preferably by four of the adhesive pads 7' respectively placed adjacent to the corners of the plate. Each of the plates most advantageously comprises a square shaped piece of sheet or plate glass 18 shown in FIG. 7, although other shapes providing opposite parallel sides could less desirably be used. On the rear surface 18a of each plate is applied spaced areas 20 of pigmented material which form the particular portion of the scene to be supplied by the plate involved. A mirror-forming deposit 22 covers the pigmented material to form mirrored areas of the plate.

The process of applying a mirrored surface to the rear of a piece of glass involves the use of chemicals which to some extent will attack the exposed edges of the pigmented materials (which may be any suitable well-known silk screen ink). If the pigmented areas 20 would be applied in the usual manner to form a picture, they would comprise individual discrete dots of pigmented material, the density of which determines the shading of the picture. Such dots of pigmented material present exposed edges all around the same which are near the center of the dots so the undercutting of the edges of each dot of pigmented material can remove most of the pigmented material forming each dot. To minimize the effect of such chemicals on the pigmented areas 20, the scene is formed by series of lines 24 of pigmented materials shown in FIG. 6, the width of which lines vary with the shading of the scene involved. Thus, in certain areas of the scene shown in FIG. 6, the thickness of the lines is so substantial that the lines of pigmented material run together to form large continuous areas of pigmented material and in other areas the lines of pigmented material are thin or disappear entirely. It is much more difficult for the mirror-forming chemicals to attack the pigmented materials when they are applied in such continuous lines of varying width since the ratio of the exposed edges to the volume of pigmented material is much smaller than in the case of the use of dots of such material.

Refer now to FIG. 8 which illustrates the method used in the most preferred form of the invention to fabricate the plates 5a, 5b, 5c, 5d, etc., in a very simple and economical manner. As illustrated, the first step is the drawing of the scene which is to be the subject of the mural involved. A picture is then taken of the artwork in the most preferred form of the invention by a special camera identified by reference numeral 25, which produces a photograph consisting of parallel lines where the thicknesses of the lines determine the shading in the picture. This camera 25 includes a special lined screen 27 positioned between the lens 29 and the film 31. The screen 27 comprises a series of straight or curved opaque lines of equal width separated by transparent areas of about the same width. The opaque and transparent areas may, for example, have widths of 0.02 of an inch. When such a screen is placed between a lens system 29 and a film where the artwork being photographed is, of course, focused on the film plane, the photograph will comprise a series of parallel lines whose thickness varies with the shading of the picture.

As shown in FIG. 8, the next step is the making of a film positive from the film negative resulting from the picture taken by the camera 25. A silk screen of the picture is then made from the film positive using well-known silk screen fabricating techniques. This generally comprises projecting the film positive on a light-sensitive coating on a silk screen mesh of at least the size of the desired mural, the unexposed portions of which coating are then removed in the conventional way. The pattern left on the silk screen will comprise a

4

series of opaque and transparent areas formed in parallel straight or wavy lines, as in the case of the original film negative where the thickness of the lines vary in accordance with the shading of the picture involved. The picture is transferred to the back surface of a mural sized piece of sheet or plate glass using suitable silk screening inks well known in the art. The back surface of the large piece of sheet or plate glass is then coated in the usual way to form a mirrored surface. Generally, the mirror is formed by applying a succession of layers of material, like tin, silver and copper, and these various layers are overlaid by a backing layer of paint.

Next, the mural sized and coated piece of glass is divided into identical segments, each segment being of the same size and shape as one of the plates 5. Indicia identifying means are placed on each of the segments to identify the position of each segment of the glass plate in the overall mural involved, and then the mural sized piece of glass is then severed along the margins of the segments to form the glass plates 5a, 5b, 5c, 5d, etc. The glass plates together with the assembly of adhesive pads 7, instruction booklet 9, etc. are then packaged in a box, like that shown in FIG. 1.

The method of making the kit just described is a very simple and relatively inexpensive one and thus a complete kit can be sold for such a relatively low price that the average purchaser can afford the same.

It should be understood that numerous modifications may be made in the most preferred form of the invention described above without deviating from the broader aspects thereof.

We claim:

1. A kit from which a wall mounted picture-displaying mural is made, said kit comprising: a series of individual transparent plates with straight sides and each of a size constituting a small fraction of the overall size of the mural to be fabricated therefrom, each of said plates having deposited on the rear surface and on only selected fractional areas thereof a pigmented material forming a different fractional part of an overall picture formed by the juxtaposed positioning of the plates in two directions, the straight sides of said plates being placeable into abutment therealong to form a substantially continuous mural, and a mirror-forming coating over the said deposited pigmented material of each plate which coating forms a mirrored surface between the areas of each plate covered by said pigmented material.

2. The kit of claim 1 wherein each of said plates has a different visible indicia thereon which identifies the position to be occupied by the plate involved in the mural to be fabricated therefrom.

3. The kit of claim 2 wherein each of said visible indicia on each plate is removably attached to the front surface thereof.

4. The kit of claim 1 wherein there are provided at least two adhesive pads for each plate, each adhesive pad being much smaller than the associated plate and each having layers of pressure-sensitive adhesive on opposite sides thereof, one of which is operable to secure the pad to the rear of any of the plates and the other of which is operable to secure the plate involved to a wall surface.

5. The kit of claim 1 wherein said deposit of pigmented material on each plate is deposited as spaced lines of such material, the width of which varies to produce a gradation of shading in the picture.

6. The kit of claim 1 wherein said glass plates are square plates of identical size arranged in orthogonal rows and columns.

65

70

75