



- (51) International Patent Classification:
G06T 7/20 (2006.01) *H04N 3/10* (2006.01)
- (21) International Application Number:
PCT/US2012/064980
- (22) International Filing Date:
14 November 2012 (14.11.2012)
- (25) Filing Language: English
- (26) Publication Language: English
- (30) Priority Data:
61/559,970 15 November 2011 (15.11.2011) US
- (71) Applicant: **MAGNA ELECTRONICS, INC.** [US/US];
2050 Auburn Rd., Auburn Hills, Michigan 48326 (US).
- (72) Inventor: **PLIEFKE, Sebastian**; Kurfürst-Eppstein-Ring
9, 63877 Sailauf (DE).
- (74) Agent: **GARDNER, LINN, BURKHART & FLORY,
LLP, AND ITS INDIVIDUAL ATTORNEYS,
NAMESLY, TIMOTHY A. FLORY**; 2851 Charlevoix
Dr., S.E., Suite 207, Grand Rapids, Michigan 49546 (US).
- (81) Designated States (*unless otherwise indicated, for every
kind of national protection available*): AE, AG, AL, AM,

AO, AT, AU, AZ, BA, BB, BG, BH, BN, BR, BW, BY,
BZ, CA, CH, CL, CN, CO, CR, CU, CZ, DE, DK, DM,
DO, DZ, EC, EE, EG, ES, FI, GB, GD, GE, GH, GM, GT,
HN, HR, HU, ID, IL, IN, IS, JP, KE, KG, KM, KN, KP,
KR, KZ, LA, LC, LK, LR, LS, LT, LU, LY, MA, MD,
ME, MG, MK, MN, MW, MX, MY, MZ, NA, NG, NI,
NO, NZ, OM, PA, PE, PG, PH, PL, PT, QA, RO, RS, RU,
RW, SC, SD, SE, SG, SK, SL, SM, ST, SV, SY, TH, TJ,
TM, TN, TR, TT, TZ, UA, UG, US, UZ, VC, VN, ZA,
ZM, ZW.

- (84) Designated States (*unless otherwise indicated, for every
kind of regional protection available*): ARIPO (BW, GH,
GM, KE, LR, LS, MW, MZ, NA, RW, SD, SL, SZ, TZ,
UG, ZM, ZW), Eurasian (AM, AZ, BY, KG, KZ, RU, TJ,
TM), European (AL, AT, BE, BG, CH, CY, CZ, DE, DK,
EE, ES, FI, FR, GB, GR, HR, HU, IE, IS, IT, LT, LU, LV,
MC, MK, MT, NL, NO, PL, PT, RO, RS, SE, SI, SK, SM,
TR), OAPI (BF, BJ, CF, CG, CI, CM, GA, GN, GQ, GW,
ML, MR, NE, SN, TD, TG).

Published:

- *without international search report and to be republished
upon receipt of that report (Rule 48.2(g))*

(54) Title: CALIBRATION SYSTEM AND METHOD FOR VEHICULAR SURROUND VISION SYSTEM

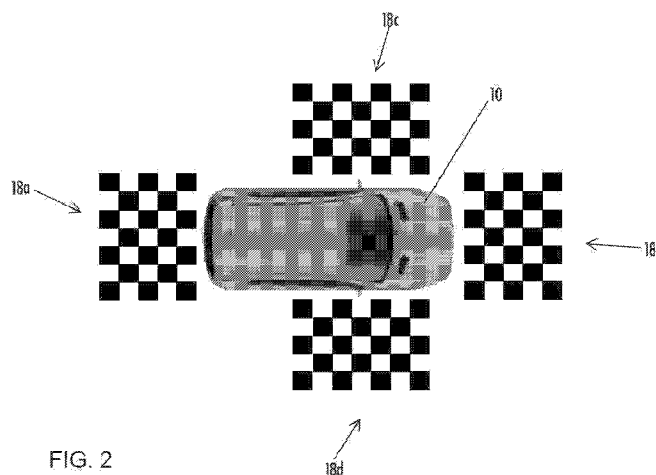

FIG. 2

(57) Abstract: A camera calibration system for calibrating cameras of a vehicle includes at least one reconfigurable calibration target established or disposed at a ground area at which a vehicle is positioned for a camera calibrating procedure. The camera calibration system is operable, responsive to an input indicative of a type or size of the vehicle positioned at the ground area, to reconfigure the at least one reconfigurable calibration target to adapt the calibration target for the particular type or size of the vehicle positioned thereat. The camera calibration system may reconfigure at least one of a size of the target and a location of the target. The camera calibration system may reconfigure the target via a covering element that selectively exposes a portion of the reconfigurable calibration target and covers another portion of the reconfigurable calibration target.



CALIBRATION SYSTEM AND METHOD FOR
VEHICULAR SURROUND VISION SYSTEM
CROSS REFERENCE TO RELATED APPLICATION

[0001] The present application claims the filing benefit of U.S. provisional application Ser. No. 61/559,970, filed Nov. 15, 2011, which is hereby incorporated herein by reference in its entirety.

FIELD OF THE INVENTION

[0002] The present invention relates to imaging systems or vision systems for vehicles.

BACKGROUND OF THE INVENTION

[0003] Use of imaging sensors in vehicle imaging systems is common and known. Examples of such known systems are described in U.S. Pat. Nos. 5,949,331; 5,670,935; and/or 5,550,677, which are hereby incorporated herein by reference in their entireties.

SUMMARY OF THE INVENTION

[0004] The present invention provides a calibration system for a vision system or imaging system for a vehicle that utilizes multiple cameras to capture images exterior of the vehicle, such as rearwardly and sidewardly and forwardly of the vehicle, such as for a surround view or bird's-eye view system of a vehicle. The cameras provide communication/data signals, including camera data or image data that may be displayed for viewing by the driver of the vehicle, and/or that is processed to merge the captured images from the cameras to provide or display a continuous surround view image for viewing by the driver of the vehicle. The cameras and/or image processing is calibrated to provide the continuous image or merged images.

[0005] According to one aspect of the present invention, the calibration system or method includes at least one reconfigurable calibration target that is reconfigurable to adapt the calibration system for different sizes or lengths or types of vehicles, such as at an end-of-line calibration procedure or as an aftermarket or after end-of-line calibration procedure. In one form, the calibration system or method may include an adjustable cover element for selectively covering a portion of a calibration target so as to selectively expose an appropriate portion of the calibration target to adapt the calibration system for different sizes or lengths or types of vehicles being calibrated. In another form, the calibration

system or method may include at least one reconfigurable display, and the calibration system or method may be operable to adjust at least one of a size of the at least one reconfigurable display and a location of the at least one reconfigurable display by electronically generating an appropriate target display responsive to the input.

[0006] According to another aspect of the present invention, the calibration or system or method may utilize a laser emitting device to project or emit a laser line cross or grid onto a ground surface by a vehicle and in an overlapping region of two fields of view of two vehicle cameras, whereby image data captured by the two cameras is processed to determine the location of the laser lines and to calibrate or adjust a camera or image processing accordingly. Responsive to such detection or determination, the captured images can be stitched or merged together to provide a substantially seamless top-down view or bird's-eye view at the vehicle via capturing images and processing images captured by the vehicle cameras.

[0007] These and other objects, advantages, purposes and features of the present invention will become apparent upon review of the following specification in conjunction with the drawings.

BRIEF DESCRIPTION OF THE DRAWINGS

[0008] FIG. 1 is a plan view of a vehicle with a vision system and imaging sensors or cameras that provide exterior fields of view in accordance with the present invention;

[0009] FIG. 2 is a plan view of a vehicle with checkerboard mats around the vehicle for calibrating the vehicle cameras;

[0010] FIGS. 3 and 4 are schematics showing different calibration target positions for different length vehicle types;

[0011] FIG. 5 is a schematic showing an adjustable calibration target that is adjustable to accommodate different length vehicle types;

[0012] FIGS. 6-10 are plan views of a vehicle, showing overlapping fields of view for calibrating one or more of the vehicle cameras;

[0013] FIG. 11 is a schematic of different characteristics used for calibration targets using a laser pointer;

[0014] FIG. 12 is a schematic showing projected straight lines within the cameras' views starting at a camera view center region and meeting at a common point within the overlapping area of two adjacent cameras views;

[0015] FIG. 13 is a schematic showing both a projected pattern in the overlapping area and projected straight lines;

[0016] FIG. 14 shows a vehicle camera view, shown with the center of the field of view highlighted (28), and with the straight lines (27) appearing curved or shaped according to the fish eye view's distortion off the center;

[0017] FIG. 15 shows a side view schematic of a vehicle having front rear and side cameras, shown with two exaggerated cones that illustrate how a pixel's covering area increases with increasing distance to the camera; and

[0018] FIG. 16 shows a four camera top view at the condition having three cameras well calibrated and the rear camera misaligned.

DESCRIPTION OF THE PREFERRED EMBODIMENTS

[0019] Referring now to the drawings and the illustrative embodiments depicted therein, a vehicle 10 includes an imaging system or vision system 12 that includes a plurality of imaging sensors or cameras (such as a rearward facing imaging sensor or camera 14a and a forwardly facing camera 14b at the front (or at the windshield) of the vehicle, and a sidewardly and/or rearwardly facing camera 14c, 14b at the sides of the vehicle), which capture images exterior of the vehicle, with the cameras having a lens for focusing images at or onto an imaging array or imaging plane of the camera (FIG. 1). The vision system 12 is operable to process image data captured by the cameras and may merge or stitch the images together to provide a top view or surround view image display at a display device 16 for viewing by the driver of the vehicle (such as by utilizing aspects of the vision systems described in PCT Application No. PCT/US10/25545, filed Feb. 26, 2010 and published Sep. 2, 2010 as International Publication No. WO 2010/099416, and/or PCT Application No. PCT/US10/47256, filed Aug. 31, 2010 and published Mar. 10, 2011 as International Publication No. WO 2011/028686, and/or PCT Application No. PCT/CA2012/000378, filed Apr. 25, 2012 (Attorney Docket MAG04 FP-1819(PCT)), and/or U.S. patent application Ser. No. 13/333,337, filed Dec. 21, 2011 (Attorney Docket DON01 P-1797), which are hereby incorporated herein by reference in their entireties). Optionally, the vision system may process image data to detect objects, such as objects to the rear of the subject or equipped vehicle during a reversing maneuver, or such as approaching or following vehicles or vehicles at a side lane adjacent to the subject or equipped vehicle or the like. The method or system or process of the present invention is operable to process

image data and calibrate the cameras so the images are accurately or optimally merged together to provide the top down or surround view display, as discussed below.

[0020] It is not uncommon at a vehicle assembly plant that the vehicle assembly line produce a mixture of vehicle types and sizes. Thus, for example, a sedan type vehicle may be immediately followed on the moving assembly line by an SUV type vehicle or a station wagon type vehicle or crossover type vehicle or the like. Some or all of this mixture of vehicle types/sizes being conveyed along the moving vehicle assembly line may be equipped with a multi-camera system that desires/requires calibration before the subject or equipped vehicle exits the assembly line. Typically, such calibration is achieved at the likes of a wheel balance station. In accordance with the present invention, when a subject multi-camera equipped vehicle of a given vehicle type/size enters the camera calibration station, a signal indicative of that vehicle type is automatically transmitted to a control that controls the various calibration targets disposed at the calibration station (typically for a surround view / bird's eye multi-camera system and typically disposed on the ground adjacent the calibration station). Responsive to receipt of that signal, the individual calibration targets are adjusted or customized to the calibration needs or specifications of that particular vehicle type. Such customization can be achieved in several ways, such as by occlusion of portions of an individual calibration target, such as via the likes of a movable cover or curtain or shroud or mask or the like. Optionally, the calibration target itself may be a reconfigurable electronic calibration target display that can reconfigurably customize the visible calibration target (that is visible or detectable or sensed by the camera or cameras being calibrated) to the expectations and/or needs of the particular vehicle type being calibrated. For example, such reconfigurable targets may comprise a large area plasma display or a large area LED or OLED display or a backlit LCD display or an e-ink display or the like, such as are commonly known in the display arts. This aspect of the present invention is also applicable to forward facing imagers (and/or optionally rearward facing imagers) utilized for the likes of automatic headlamp control, lane departure warning, forward collision warning, traffic sign recognition, vehicle detection and pedestrian detection and/or the like (such as described in U.S. Pat. Nos. 5,550,677; 5,670,935; 5,760,962; 5,796,094; 5,877,897; 6,302,545; 6,396,397; 6,690,268; 7,859,565; 8,027,029 and/or 8,070,332, which are all hereby incorporated herein by reference in their entireties), where a reconfigurable electronic target may be disposed forward of the vehicle

so as to be viewed by the forward facing imager as the vehicle equipped with the imager passes along the assembly line and/or while the vehicle is at a calibration station for other exterior viewing cameras of that vehicle (such as, for example, a surround view / bird's eye system). The calibration system thus may provide a reconfigurable calibration target (or multiple reconfigurable calibration targets) that is/are reconfigurable to adapt the calibration system for the particular size/type of vehicle that is at the calibration station.

[0021] FIG. 16 shows an example of a four camera top view at the condition having three cameras well aligned (calibrated) and one camera misaligned (miscalibrated). It comes to breaks of straight lines (in nature) crossing stitching borderlines. For hindering or correcting miscalibration typically, cameras and/or processing of such vehicular surround view vision systems are calibrated at an end of line calibration process at the vehicle assembly plant. Such calibration systems typically comprise a plurality of calibration targets 18a, 18b, 18c, 18d fixed on the ground, whereby the vehicle 10 is driven to a position generally at the center of the targets, such as shown in FIG. 2. Vehicle production lines are often used for more than one vehicle type or platform. The consequences of these generalizations or shared production lines are that the vehicle dimensions vary and, in end-of-line calibration zones or areas, the calibration targets can often only be optimally positioned for one vehicle variant or type or lengths, and thus may be less than optimally positioned for other vehicle variants or types or lengths. Only one target is typically placed at each target position because the end-of-line processing algorithms may get confused if more than one calibration target is visible in the field of view of the camera. Thus, the calibration system or process may be designed for one vehicle type or variant to provide optimal calibration of that vehicle type, while the calibration for the other vehicle types that are manufactured at that production line or facility may be less than optimal. Thus, the end-of-line calibration results may not be optimized or precise for all of the vehicle types manufactured at a given assembly facility or production line.

[0022] As can be seen with reference to FIGS. 3 and 4, due to different length and sized vehicles, the position of the cameras relative to the calibration targets vary because of the dimensions of the vehicle that is being calibrated, which results in the distance between the cameras and the respective targets sometimes being greater and sometimes being smaller or reduced. Thus, algorithmic adjustment of the processing may be needed to

adapt the processing for the particular distances between the cameras and calibration targets during the calibration process.

[0023] It is desirable to have the targets at fixed or constant or non-varying distances from the cameras for all vehicles so that the processing algorithms may be configured or optimized for enhanced precision and thus enhanced calibrating of the system. For example, in order to optimize the calibration of systems on different length vehicles, the target 18a in FIG. 3 should be disposed further away from target 18b to accommodate a longer vehicle type, while the target 18a in FIG. 4 should be disposed closer to target 18b to accommodate a shorter vehicle type.

[0024] The present invention provides multiple targets at the calibration area or zone (and optionally may provide multiple targets at one or more of the target locations, such as the front, sides and/or rear of the vehicle, or larger targets at one or more of the target locations), and the different targets or portions of the targets are selectively exposed (or different sized and located targets are selectively generated, such as via a reconfigurable display or the like that is reconfigured for the vehicle being calibrated) for different vehicle sizes or types while the non-used targets or target portions (the targets or target portions that are not needed for calibrating the particular vehicle being calibrated) are selectively covered, such as by a mechanical device or the like (such as shown in FIG. 5).

[0025] In the illustrated embodiment, of FIG. 5, target 18a' comprises a larger elongated target that encompasses the areas covered by the targets 18a in FIGS. 3 and 4. A cover or blocking or hiding element 20 is disposed at the larger target 18a', and is selectively disposed at or over a portion of the target 18a' that is not needed for calibrating the particular vehicle that is at the calibration area or zone. The cover 20 may comprise any suitable covering or blocking element. For example, the cover element or panel or frame may comprise a movable panel or frame 20a (FIG. 5) that is generally linearly movable over and along the larger target to one of at least two positions to block the non-used portion of the target, while exposing the portion of the target that is appropriate for the particular vehicle or vehicle type that is present at the calibration zone (i.e., at the appropriate distance from the respective camera for that particular vehicle or vehicle type).

[0026] Optionally, the cover element or panel or frame may comprise a panel that may be flipped between two positions, with the cover, when in a first position, covering about a half of the target 18a' and, when in a second position, covering about the other half of the

target 18a'. For example, the cover may pivot or flip via a hinged mounting or attachment at or near the target, with the cover panel hingedly mounted at the target and being pivotable about its hinge axis between its first and second covering positions.

[0027] Thus, the end of line calibration process or system of the present invention provides enhanced or optimized calibration target positions for multiple vehicle types or sizes. Thus, the processing algorithm that calibrates the cameras and/or vision system may be common for all vehicles and may calibrate all sizes or types of vehicles in a similar manner and to a similar degree of precision. Although shown and described as having a cover that is movable over a larger target between two positions, it is envisioned that multiple covers and/or multiple covering positions may be provided to selectively expose more than two portions of a larger target to adapt the calibration system for three or more types or lengths or sizes of vehicles. Also, although shown and described as providing a movable cover at one target that is at the front or rear of the vehicle being calibrated, it is envisioned that a target or targets at the side or sides of the vehicle may also be selectively exposed/covered to adapt the calibration system for different width vehicles and/or for vehicles with the side cameras disposed at different locations along the vehicles (relative to the front and/or rear of the vehicle). It is further envisioned that the calibration system may comprise one or more calibration targets that are movable along the floor of the target zone to position the calibration target at an appropriate location relative to the camera/cameras of a vehicle at the calibration zone (for example, the target may mechanically move along the floor of the calibration station or target zone or may be otherwise mechanically reconfigured or a target may be projected or displayed or reconfigured to provide the desired size and location of the targets at the floor of the calibration station or target zone). The calibration system or method of the present invention thus provides selective exposure and blocking/hiding of portions of at least one calibration target (or selective generation or reconfiguration of different sized and located targets) at a calibration zone to adapt the calibration system for different types or sizes of vehicles, such that the same or common processing or calibrating algorithm provides enhanced or optimal processing and calibration of the vehicle systems for two or more vehicle types or sizes.

[0028] Even though the vehicle vision system may be optimally calibrated when the vehicle leaves the production facility, one or more cameras of the vehicle vision system may

become uncalibrated or decalibrated as the vehicle is driven and over time and during usage of the vehicle or when replacing one or more cameras. When this happens, the decalibrated camera(s) must be re-calibrated to again properly function.

[0029] The present invention also provides an aftermarket or after end-of-line calibration process that calibrates one or more decalibrated cameras of a vehicle (such as at a service station or the like). The recalibration process or system of the present invention comprises use of a handheld laser calibration target tool that emits a beam pattern at an overlapping field of view area of two cameras, whereby the system may detect the location of the beam pattern in each of the two cameras' fields of view and adjust or recalibrate the decalibrated camera accordingly. As shown in FIGS. 6-10, a calibration system may perform extrinsic calibration of a decalibrated camera (such as, in the illustrated example, the side camera 14d of vehicle 10) using an extrinsically calibrated reference camera (such as, in the illustrated example, the front camera 14b), and using the overlapping regions 22 of the fields of view 15b, 15d of the cameras 14b, 14d for the calibration. The calibration system may detect one or more characteristic points 26 that are or can be found in both camera fields of view 15b, 15d and in the overlapping region 22. The camera position and orientation of the decalibrated camera 14d is fitted or adjusted based on the known position and orientation of the reference camera or calibrated camera 14a. For example, the system may extract the camera position and orientation of the calibrated or reference camera 14a to calibrate the decalibrated camera 14d knowing the position and orientation of the reference camera. As shown in FIG. 10, the accuracy of the calibration system may be enhanced by using two overlapping regions, such as overlapping region 22 of the fields of view 15b, 15d of the front and side cameras 14b, 14d and overlapping region 24 of the fields of view 15a, 15d of the rear and side cameras 14a, 14d in the illustrated example.

[0030] As an addition or alternative to the inventive system discussed above, the system may not just utilize the dedicated points of a projected pattern within the overlapping region, but also a pattern, or preferably straight lines, which extends not just over the overlapping region but beyond its borderlines. It is suggested to place (drawing or sticking to a target on the ground or preferably projecting) straight lines 27, which start in the center region 28 of the field of view of the respective cameras at a distance from the vehicle and that end or meet or cross or intersect at a common point within the overlapping view

region, such as shown in FIG. 12 (with FIG. 13 showing both a projected pattern in the overlapping area and projected straight lines). Since the surround view cameras may all comprise fisheye lenses (or wide angle image distorting lenses or lens systems or lens optics) at the imaging sensor or pixelated imaging array of the respective camera (thus providing a wide angle "fisheye" field of view), the center region 28 has a much better resolution as compared to the regions at the far ends at the side as like in the overlapping region, such as can be seen with reference to FIG. 14. By detecting the line directions in each camera's center region, the system may be operable to determine the crossing points at the far ends of the lines even when these are hardly discernible or discriminable in the overlapping region (done for both respective cameras of one overlapping region). This method and algorithm allows for a more accurate calibration of the cameras. The accuracy will be dependent, at least in part, on the resolution of the camera in the center region of the field of view.

[0031] Typically, the limiting for discriminating differences within the center of a fisheye image is the pixel resolution. This means the smallest area which can be discriminated equates to the covering area of one pixel plus / minus the range until a neighboring pixel becomes triggered. Assuming a round covering area this is typically a half pixel steradian.

$$\text{Accuracy steradian} = \frac{\text{steradian}}{\text{per Pixel}} \cdot (1 \pm 0,5) \text{ Pixel}$$

The covering area of one pixel is typically more as like a square. Since the covering area is a steradian (or two orthogonal angles describing the width and heights of a square), the covered area increases exponentially with increasing distance such as like illustrated in FIG. 15.

[0032] According to another aspect of the present invention, the projection device may comprise a hand held device or a device mounted on a tripod or such which possesses a wired or wireless data connection attached to or linked to or in communication with the calibration system for instructing the person operating the hand held device if and how to change the projecting position or to control the projection direction automated or half automated. The tripod or device may have actuators to do this. The operator may have to carry the projector around the vehicle at least once to calibrate all of the overlapping regions.

[0033] When calibrating cameras using the overlapping camera views, the process of localizing corresponding points in the overlapping camera views can be challenging. The probability of localizing a point in both views is higher at points at the ground plane and is lower at points that are on an object or objects having a height or distance above the ground plane. Also, the resolution of images in the overlapping regions may be quite low, such that several points or characteristics may be needed to get sufficient precision by statistic analysis. Thus, successfully extracting points from a real world scene may be highly dependent on the surrounding textures or contours or objects at or near the vehicle and in the overlapping fields of view and on the lighting conditions at or near the vehicle. Because of this, the checkerboard targets (such as shown in FIG. 2) are used for calibration purposes, but, because of the low resolution in the overlapping image region, the rectangles of the checker board may have to be large, and thus less corresponding points may be found and used for fitting the captured images and calibrating the decalibrated camera.

[0034] The present invention provides a calibration process or system or method that utilizes a laser pointer with a point approximating friendly characteristic (such as, for example, a cross or grid lines or the like, that form points via the crossing or intersection of the laser lines). In order to calibrate the camera, the laser pointer is moved or established in the overlap region and images are captured nearly synchronously with both cameras (such as the front and side cameras as shown in FIGS. 6-10). The system may approximate the intersection point or points with sub pixel precision by fitting complete laser lines and may determine or calculate their intersection. After the system collects enough point pairs (points that are present in the overlap region and captured by both cameras), the system can begin or conduct extrinsic calculations.

[0035] Optionally, point extraction by the cameras and system may be improved by pulsing the laser, whereby consecutive images may be captured with the laser enabled and then disabled. The subtraction of both images will eliminate static content and will highlight the laser lines in the overlapping region. Optionally, the laser may be synchronized with the image capturing frame rate or running at a certain frequency, which may be harmonized with the speed or frame rate of the cameras.

[0036] An aftermarket or service center (such as a Ford or General Motors or Toyota dealership or the like) may have to recalibrate a multi-camera system due to, for example,

replacement of a broken away camera-equipped exterior mirror that forms part of the subject vehicle's multi-camera system. The particular vehicle type (for example, a Mercedes C-Class or E-Class or M-Class or the like) will require its own particular calibration target or targets at the service center. In accordance with the present invention, a light projection system is provided at the dealership (or other location suitable for use as a camera calibration station) that projects the required lines or targets onto the ground adjacent the to-be-calibrated subject vehicle in the form of a projected light pattern or target. And the particular pattern projected is electronically selective by the service center or technician in the appropriate form for that particular vehicle type being serviced. Preferably, the projected pattern on the ground is produced by use of a laser / movable mirror or a movable laser projection system that by rapidly moving a laser light beam effectively "writes" the desired pattern onto the floor adjacent the subject vehicle. In accordance with this aspect of the present invention, the service technician need only key in or input the particular vehicle model or type to be calibrated, and the projection system of the present invention then automatically and appropriately generates or "writes" the desired or appropriate or selected calibration pattern on the ground in a manner appropriate for multi-camera calibration for that particular vehicle model. Alternatively, any light projector, such as with an appropriate mask, may be used (such as a mask that is electronically reconfigurable such as by using a transmissive liquid crystal panel or the like).

[0037] Thus, the present invention provides an after end-of-line calibration process or system or method (such as an aftermarket calibration system or the like at a vehicle service station or the like) that enhances detection of common points in the overlapping regions of two adjacent cameras of the vehicle (such as an overlapping field of view portion of the front and side cameras or the rear and side cameras). The system or procedure may comprise, for example, parking the vehicle at a generally flat surface with about a two meter open or un-blocked space around the perimeter of the vehicle, at least at the fields of view of the decalibrated camera and the adjacent reference camera. The calibration function is activated for a particular camera (such as a decalibrated camera or a camera which may be a threshold degree of calibration) or for the entire vision system. The system may prompt a service technician or user to generate or present the calibration target at a particular overlapping region by the vehicle, whereby the service technician or

user may enable and use the handheld laser calibration target tool and may direct or place the focus point of the emitted grid or cross or the like in the overlap region of the two cameras. The characteristic of the created or generated target will show pairs of lines in both of the camera views that encompass the overlapping region.

[0038] If the system detects the focus point of the calibration target with good or sufficient precision, the system may acknowledge such detection, such as with an alert or visual or audible signal, so that the service technician knows that the focus point was detected. The system may then prompt the user or service technician to modify the location or position of the focus point (while maintaining the focus point in the overlapping region). This procedure may be repeated multiple times until enough points are detected and extracted for both or all of the cameras that are necessary to calibrate the camera or cameras. When the system has detected and captured images of a sufficient number of focus points, the service calibration system is operable to calculate and calibrate the cameras from the focus point image data. Because the focus points are at the ground level by the vehicle and are actual and consistent lines and points (at the intersection of the laser lines), the present invention provides enhanced detection and recognition and processing of the focus points in the captured images and thus enhanced processing of the image data and calibration of the cameras.

[0039] Thus, using the laser focus point system of the present invention, the point extraction is independent of the ground texture or contours or objects surrounding the vehicle and is independent of the lighting conditions at or surrounding the vehicle. Also, during the calibration procedure, the number of extracted points could be readily increased, and the precision of the extracted extrinsic parameters may be adjusted. With the use of the laser focus points, the laser focus points can be generated or projected or emitted at any locations in the overlapping portion of the fields of view, and no alignment of targets is necessary. The camera images between the different views should be made nearly synchronously, and, by using differential images, at least two images are stored in internal memory during the calibration process. At least one reference camera with known extrinsic parameters is necessary, and then the adjacent camera or cameras can be calibrated accordingly.

[0040] The imaging sensor or camera that captures the image data for image processing may comprise any suitable camera or sensing device, such as, for example, an array of a

plurality of photosensor elements arranged in at least 640 columns and at least 480 rows (at least a 640 x 480 imaging array), with a respective lens focusing images onto respective portions of the array. The photosensor array may comprise a plurality of photosensor elements arranged in a photosensor array having rows and columns. The logic and control circuit of the imaging sensor may function in any known manner, and the image processing and algorithmic processing may comprise any suitable means for processing the images and/or image data. For example, the vision system and/or processing and/or camera and/or circuitry may utilize aspects described in U.S. Pat. Nos. 7,005,974; 5,760,962; 5,877,897; 5,796,094; 5,949,331; 6,222,447; 6,302,545; 6,396,397; 6,498,620; 6,523,964; 6,611,202; 6,201,642; 6,690,268; 6,717,610; 6,757,109; 6,802,617; 6,806,452; 6,822,563; 6,891,563; 6,946,978; 7,859,565; 5,550,677; 5,670,935; 6,636,258; 7,145,519; 7,161,616; 7,230,640; 7,248,283; 7,295,229; 7,301,466; 7,592,928; 7,881,496; 7,720,580; 7,038,577; 6,882,287; 5,929,786 and/or 5,786,772, and/or PCT Application No. PCT/US2010/047256, filed Aug. 31, 2010 and published Mar. 10, 2011 as International Publication No. WO 2011/028686 and/or International Publication No. WO 2010/099416, published Sep. 2, 2010, and/or PCT Application No. PCT/US10/25545, filed Feb. 26, 2010 and published Sep. 2, 2010 as International Publication No. WO 2010/099416, and/or PCT Application No. PCT/US2012/048800, filed Jul. 30, 2012 (Attorney Docket MAG04 FP-1908(PCT)), and/or PCT Application No. PCT/US2012/048110, filed Jul. 25, 2012 (Attorney Docket MAG04 FP-1907(PCT)), and/or PCT Application No. PCT/CA2012/000378, filed Apr. 25, 2012 (Attorney Docket MAG04 FP-1819(PCT)), and/or PCT Application No. PCT/US2012/056014, filed Sep. 19, 2012 (Attorney Docket MAG04 FP-1937(PCT)), and/or PCT Application No. PCT/US12/57007, filed Sep. 25, 2012 (Attorney Docket MAG04 FP-1942(PCT)), and/or PCT Application No. PCT/US2012/061548, filed Oct. 24, 2012 (Attorney Docket MAG04 FP-1949(PCT)), and/or PCT Application No. PCT/US2012/062906, filed Nov. 1, 2012 (Attorney Docket MAG04 FP-1953(PCT)), and/or PCT Application No. PCT/US2012/063520, filed Nov. 5, 2012 (Attorney Docket MAG04 FP-1954(PCT)), and/or U.S. patent applications, Ser. No. 13/660,306, filed Oct. 25, 2012 (Attorney Docket MAG04 P-1950); Ser. No. 13/653,577, filed Oct. 17, 2012 (Attorney Docket MAG04 P-1948); and/or Ser. No. 13/534,657, filed Jun. 27, 2012 (Attorney Docket MAG04 P-1892), and/or U.S. provisional applications, Ser. No. 61/710,924, filed Oct. 8, 2012; Ser. No. 61/696,416, filed Sep. 4, 2012; Ser. No.

61/682,995, filed Aug. 14, 2012; Ser. No. 61/682,486, filed Aug. 13, 2012; Ser. No. 61/680,883, filed Aug. 8, 2012; Ser. No. 61/678,375, filed Aug. 1, 2012; Ser. No. 61/676,405, filed Jul. 27, 2012; Ser. No. 61/666,146, filed Jun. 29, 2012; Ser. No. 61/653,665, filed May 31, 2012; Ser. No. 61/653,664, filed May 31, 2012; Ser. No. 61/648,744, filed May 18, 2012; Ser. No. 61/624,507, filed Apr. 16, 2012; Ser. No. 61/616,126, filed Mar. 27, 2012; Ser. No. 61/615,410, filed Mar. 26, 2012; Ser. No. 61/613,651, filed Mar. 21, 2012; Ser. No. 61/607,229, filed Mar. 6, 2012; Ser. No. 61/605,409, filed Mar. 1, 2012; Ser. No. 61/602,878, filed Feb. 24, 2012; Ser. No. 61/602,876, filed Feb. 24, 2012; Ser. No. 61/600,205, filed Feb. 17, 2012; Ser. No. 61/588,833, filed Jan. 20, 2012; Ser. No. 61/583,381, filed Jan. 5, 2012; Ser. No. 61/579,682, filed Dec. 23, 2011; Ser. No. 61/570,017, filed Dec. 13, 2011; Ser. No. 61/568,791, filed Dec. 9, 2011; Ser. No. 61/567,446, filed Dec. 6, 2011; Ser. No. 61/567,150, filed Dec. 6, 2011; Ser. No. 61/565,713, filed Dec. 1, 2011; Ser. No. 61/563,965, filed Nov. 28, 2011, which are all hereby incorporated herein by reference in their entireties. The system may communicate with other communication systems via any suitable means, such as by utilizing aspects of the systems described in PCT Application No. PCT/US10/038477, filed Jun. 14, 2010, and/or U.S. patent application Ser. No. 13/202,005, filed Aug. 17, 2011 (Attorney Docket MAG04 P-1595), and/or U.S. provisional applications, Ser. No. 61/650,667, filed May 23, 2012; Ser. No. 61/579,682, filed Dec. 23, 2011; Ser. No. 61/565,713, filed Dec. 1, 2011, which are hereby incorporated herein by reference in their entireties.

[0041] The imaging device and control and image processor and any associated illumination source, if applicable, may comprise any suitable components, and may utilize aspects of the cameras and vision systems described in U.S. Pat. Nos. 5,550,677; 5,877,897; 6,498,620; 5,670,935; 5,796,094; 6,396,397; 6,806,452; 6,690,268; 7,005,974; 7,123,168; 7,004,606; 6,946,978; 7,038,577; 6,353,392; 6,320,176; 6,313,454; and 6,824,281, and/or International Publication No. WO 2010/099416, published Sep. 2, 2010, and/or PCT Application No. PCT/US10/47256, filed Aug. 31, 2010 and published Mar. 10, 2011 as International Publication No. WO 2011/028686, and/or U.S. patent application Ser. No. 12/508,840, filed Jul. 24, 2009, and published Jan. 28, 2010 as U.S. Pat. Publication No. US 2010-0020170, and/or PCT Application No. PCT/US2012/048110, filed Jul. 25, 2012 (Attorney Docket MAG04 FP-1907(PCT)), and/or U.S. patent application Ser.

No. 13/534,657, filed Jun. 27, 2012 (Attorney Docket MAG04 P-1892), which are all hereby incorporated herein by reference in their entireties. The camera or cameras may comprise any suitable cameras or imaging sensors or camera modules, and may utilize aspects of the cameras or sensors described in U.S. patent applications, Ser. No. 12/091,359, filed Apr. 24, 2008 and published Oct. 1, 2009 as U.S. Publication No. US-2009-0244361, and/or Ser. No. 13/260,400, filed Sep. 26, 2011 (Attorney Docket MAG04 P-1757), and/or U.S. Pat. Nos. 7,965,336 and/or 7,480,149, which are hereby incorporated herein by reference in their entireties. The imaging array sensor may comprise any suitable sensor, and may utilize various imaging sensors or imaging array sensors or cameras or the like, such as a CMOS imaging array sensor, a CCD sensor or other sensors or the like, such as the types described in U.S. Pat. Nos. 5,550,677; 5,670,935; 5,760,962; 5,715,093; 5,877,897; 6,922,292; 6,757,109; 6,717,610; 6,590,719; 6,201,642; 6,498,620; 5,796,094; 6,097,023; 6,320,176; 6,559,435; 6,831,261; 6,806,452; 6,396,397; 6,822,563; 6,946,978; 7,339,149; 7,038,577; 7,004,606; and/or 7,720,580, and/or U.S. patent application Ser. No. 10/534,632, filed May 11, 2005, now U.S. Pat. No. 7,965,336; and/or PCT Application No. PCT/US2008/076022, filed Sep. 11, 2008 and published Mar. 19, 2009 as International Publication No. WO/2009/036176, and/or PCT Application No. PCT/US2008/078700, filed Oct. 3, 2008 and published Apr. 9, 2009 as International Publication No. WO/2009/046268, which are all hereby incorporated herein by reference in their entireties.

[0042] The camera module and circuit chip or board and imaging sensor may be implemented and operated in connection with various vehicular vision-based systems, and/or may be operable utilizing the principles of such other vehicular systems, such as a vehicle headlamp control system, such as the type disclosed in U.S. Pat. Nos. 5,796,094; 6,097,023; 6,320,176; 6,559,435; 6,831,261; 7,004,606; 7,339,149; and/or 7,526,103, which are all hereby incorporated herein by reference in their entireties, a rain sensor, such as the types disclosed in commonly assigned U.S. Pat. Nos. 6,353,392; 6,313,454; 6,320,176; and/or 7,480,149, which are hereby incorporated herein by reference in their entireties, a vehicle vision system, such as a forwardly, sidewardly or rearwardly directed vehicle vision system utilizing principles disclosed in U.S. Pat. Nos. 5,550,677; 5,670,935; 5,760,962; 5,877,897; 5,949,331; 6,222,447; 6,302,545; 6,396,397; 6,498,620; 6,523,964; 6,611,202; 6,201,642; 6,690,268; 6,717,610; 6,757,109; 6,802,617; 6,806,452; 6,822,563;

6,891,563; 6,946,978; and/or 7,859,565, which are all hereby incorporated herein by reference in their entireties, a trailer hitching aid or tow check system, such as the type disclosed in U.S. Pat. No. 7,005,974, which is hereby incorporated herein by reference in its entirety, a reverse or sideward imaging system, such as for a lane change assistance system or lane departure warning system or for a blind spot or object detection system, such as imaging or detection systems of the types disclosed in U.S. Pat. Nos. 7,720,580; 7,038,577; 5,929,786 and/or 5,786,772, and/or U.S. pat. applications, Ser. No. 11/239,980, filed Sep. 30, 2005, now U.S. Pat. No. 7,881,496, and/or U.S. provisional applications, Ser. No. 60/628,709, filed Nov. 17, 2004; Ser. No. 60/614,644, filed Sep. 30, 2004; Ser. No. 60/618,686, filed Oct. 14, 2004; Ser. No. 60/638,687, filed Dec. 23, 2004, which are hereby incorporated herein by reference in their entireties, a video device for internal cabin surveillance and/or video telephone function, such as disclosed in U.S. Pat. Nos. 5,760,962; 5,877,897; 6,690,268; and/or 7,370,983, and/or U.S. patent application Ser. No. 10/538,724, filed Jun. 13, 2005 and published Mar. 9, 2006 as U.S. Publication No. US-2006-0050018, which are hereby incorporated herein by reference in their entireties, a traffic sign recognition system, a system for determining a distance to a leading or trailing vehicle or object, such as a system utilizing the principles disclosed in U.S. Pat. Nos. 6,396,397 and/or 7,123,168, which are hereby incorporated herein by reference in their entireties, and/or the like.

[0043] Optionally, the circuit board or chip may include circuitry for the imaging array sensor and or other electronic accessories or features, such as by utilizing compass-on-a-chip or EC driver-on-a-chip technology and aspects such as described in U.S. Pat. No. 7,255,451 and/or U.S. Pat. No. 7,480,149; and/or U.S. patent applications, Ser. No. 11/226,628, filed Sep. 14, 2005 and published Mar. 23, 2006 as U.S. Publication No. US-2006-0061008, and/or Ser. No. 12/578,732, filed Oct. 14, 2009 (Attorney Docket DON01 P-1564), which are hereby incorporated herein by reference in their entireties.

[0044] Optionally, the vision system may include a display for displaying images captured by one or more of the imaging sensors for viewing by the driver of the vehicle while the driver is normally operating the vehicle. Optionally, for example, the vision system may include a video display device disposed at or in the interior rearview mirror assembly of the vehicle, such as by utilizing aspects of the video mirror display systems described in U.S. Pat. No. 6,690,268 and/or U.S. patent application Ser. No. 13/333,337, filed Dec. 21, 2011

(Attorney Docket DON01 P-1797), which are hereby incorporated herein by reference in their entireties. The video mirror display may comprise any suitable devices and systems and optionally may utilize aspects of the compass display systems described in U.S. Pat. Nos. 7,370,983; 7,329,013; 7,308,341; 7,289,037; 7,249,860; 7,004,593; 4,546,551; 5,699,044; 4,953,305; 5,576,687; 5,632,092; 5,677,851; 5,708,410; 5,737,226; 5,802,727; 5,878,370; 6,087,953; 6,173,508; 6,222,460; 6,513,252; and/or 6,642,851, and/or European patent application, published Oct. 11, 2000 under Publication No. EP 0 1043566, and/or U.S. patent application Ser. No. 11/226,628, filed Sep. 14, 2005 and published Mar. 23, 2006 as U.S. Publication No. US-2006-0061008, which are all hereby incorporated herein by reference in their entireties. Optionally, the video mirror display screen or device may be operable to display images captured by a rearward viewing camera of the vehicle during a reversing maneuver of the vehicle (such as responsive to the vehicle gear actuator being placed in a reverse gear position or the like) to assist the driver in backing up the vehicle, and optionally may be operable to display the compass heading or directional heading character or icon when the vehicle is not undertaking a reversing maneuver, such as when the vehicle is being driven in a forward direction along a road (such as by utilizing aspects of the display system described in PCT Application No. PCT/US2011/056295, filed Oct. 14, 2011 and published Apr. 19, 2012 as International Publication No. WO 2012/051500, which is hereby incorporated herein by reference in its entirety).

[0045] Optionally, the vision system (utilizing the forward facing camera and a rearward facing camera and other cameras disposed at the vehicle with exterior fields of view) may be part of or may provide a display of a top-down view or birds-eye view system of the vehicle or a surround view at the vehicle, such as by utilizing aspects of the vision systems described in PCT Application No. PCT/US10/25545, filed Feb. 26, 2010 and published on Sep. 2, 2010 as International Publication No. WO 2010/099416, and/or PCT Application No. PCT/US10/47256, filed Aug. 31, 2010 and published Mar. 10, 2011 as International Publication No. WO 2011/028686, and/or PCT Application No. PCT/US2011/062834, filed Dec. 1, 2011 and published Jun. 7, 2012 as International Publication No. WO2012/075250, and/or PCT Application No. PCT/US2012/048993, filed Jul. 31, 2012 (Attorney Docket MAG04 FP-1886(PCT)), and/or PCT Application No. PCT/US11/62755, filed Dec. 1, 2011 and published Jun. 7, 2012 as International Publication No. WO 2012-075250, and/or PCT

Application No. PCT/CA2012/000378, filed Apr. 25, 2012 (Attorney Docket MAG04 FP-1819(PCT)), and/or U.S. patent application Ser. No. 13/333,337, filed Dec. 21, 2011 (Attorney Docket DON01 P-1797), and/or U.S. provisional applications, Ser. No. 61/615,410, filed Mar. 26, 2012; Ser. No. 61/588,833, filed Jan. 20, 2012; Ser. No. 61/570,017, filed Dec. 13, 2011; and/or Ser. No. 61/568,791, filed Dec. 9, 2011, which are hereby incorporated herein by reference in their entireties.

[0046] Optionally, the video mirror display may be disposed rearward of and behind the reflective element assembly and may comprise a display such as the types disclosed in U.S. Pat. Nos. 5,530,240; 6,329,925; 7,855,755; 7,626,749; 7,581,859; 7,446,650; 7,370,983; 7,338,177; 7,274,501; 7,255,451; 7,195,381; 7,184,190; 5,668,663; 5,724,187 and/or 6,690,268, and/or in U.S. patent applications, Ser. No. 12/091,525, filed Apr. 25, 2008, now U.S. Pat. No. 7,855,755; Ser. No. 11/226,628, filed Sep. 14, 2005 and published Mar. 23, 2006 as U.S. Publication No. US-2006-0061008; and/or Ser. No. 10/538,724, filed Jun. 13, 2005 and published Mar. 9, 2006 as U.S. Publication No. US-2006-0050018, which are all hereby incorporated herein by reference in their entireties. The display is viewable through the reflective element when the display is activated to display information. The display element may be any type of display element, such as a vacuum fluorescent (VF) display element, a light emitting diode (LED) display element, such as an organic light emitting diode (OLED) or an inorganic light emitting diode, an electroluminescent (EL) display element, a liquid crystal display (LCD) element, a video screen display element or backlit thin film transistor (TFT) display element or the like, and may be operable to display various information (as discrete characters, icons or the like, or in a multi-pixel manner) to the driver of the vehicle, such as passenger side inflatable restraint (PSIR) information, tire pressure status, and/or the like. The mirror assembly and/or display may utilize aspects described in U.S. Pat. Nos. 7,184,190; 7,255,451; 7,446,924 and/or 7,338,177, which are all hereby incorporated herein by reference in their entireties. The thicknesses and materials of the coatings on the substrates of the reflective element may be selected to provide a desired color or tint to the mirror reflective element, such as a blue colored reflector, such as is known in the art and such as described in U.S. Pat. Nos. 5,910,854; 6,420,036; and/or 7,274,501, which are hereby incorporated herein by reference in their entireties.

[0047] Optionally, the display or displays and any associated user inputs may be associated with various accessories or systems, such as, for example, a tire pressure monitoring system or a passenger air bag status or a garage door opening system or a telematics system or any other accessory or system of the mirror assembly or of the vehicle or of an accessory module or console of the vehicle, such as an accessory module or console of the types described in U.S. Pat. Nos. 7,289,037; 6,877,888; 6,824,281; 6,690,268; 6,672,744; 6,386,742; and 6,124,886, and/or U.S. patent application Ser. No. 10/538,724, filed Jun. 13, 2005 and published Mar. 9, 2006 as U.S. Publication No. US-2006-0050018, which are hereby incorporated herein by reference in their entireties.

[0048] Changes and modifications to the specifically described embodiments may be carried out without departing from the principles of the present invention, which is intended to be limited only by the scope of the appended claims as interpreted according to the principles of patent law.

CLAIMS:

1. A camera calibration system for calibrating at least one camera of a vehicle, said camera calibration system comprising:

at least one reconfigurable calibration target established at a ground area at or proximate where a vehicle is positioned for a camera calibrating procedure; and

wherein said camera calibration system is operable, responsive to an input indicative of a type or size of the vehicle positioned at the ground area, to reconfigure said reconfigurable calibration target to adapt said reconfigurable calibration target for that particular type or size of vehicle positioned thereat.

2. The camera calibration system of claim 1, wherein said at least one reconfigurable calibration target comprises a plurality of reconfigurable calibration targets.

3. The camera calibration system of claim 2, wherein at least some of said reconfigurable calibration targets are established at side regions of the vehicle positioned at the ground area.

4. The camera calibration system of claim 2, wherein said reconfigurable calibration targets comprise checkerboard type targets disposed at forward, rearward and sideward regions of the vehicle positioned at the ground area.

5. The camera calibration system of claim 2, wherein at least one of said reconfigurable calibration targets comprises a larger reconfigurable calibration target as compared to at least one other of said reconfigurable calibration target.

6. The camera calibration system of claim 5, wherein said one of said reconfigurable calibration targets comprises a forward or rearward one of said reconfigurable calibration targets.

7. The camera calibration system of claim 1, wherein said camera calibration system is operable to reconfigure at least one of a size of said at least one reconfigurable

calibration target and a location of at least one of said at least one reconfigurable calibration target.

8. The camera calibration system of claim 7, wherein said camera calibration system reconfigures said at least one reconfigurable calibration target via a covering element that selectively exposes a portion of said at least one reconfigurable calibration target and covers another portion of said at least one reconfigurable calibration target.

9. The camera calibration system of claim 8, wherein said covering element comprises a linearly movable covering element that is movable along and over said one of said reconfigurable calibration target.

10. The camera calibration system of claim 8, wherein said adjustable covering element comprises a pivotable covering element that is pivotable about a hinge element between first and second covering positions.

11. The camera calibration system of claim 1, wherein said at least one reconfigurable calibration target comprises at least one reconfigurable display.

12. The camera calibration system of claim 11, wherein said camera calibration system is operable to adjust at least one of a size of said at least one reconfigurable display and a location of said at least one reconfigurable display by electronically generating an appropriate target display responsive to said input.

13. The camera calibration system of claim 12, wherein said at least one reconfigurable display comprises a plurality of reconfigurable displays.

14. The camera calibration system of claim 13, wherein said camera calibration system electronically generates a reconfigurable display at at least some of the forward, rearward and sideward regions of the vehicle positioned at the ground area.

15. A camera calibration method for calibrating at least one camera of a vehicle, said camera calibration method comprising:

providing a vehicle, said vehicle having a forward camera, a rearward camera and opposite side cameras;

generating a target at an overlapping portion of the fields of view of two of said cameras by use of light projection;

capturing images of the target at the overlapping portion;

processing image data to detect the target in the captured images; and

calibrating at least one of said cameras responsive to detecting the target.

16. The camera calibration method of claim 15, wherein generating a target and capturing images steps are repeated to collect multiple captured images, and wherein processing image data comprises processing image data of said multiple captured images to detect the target in multiple captured images.

17. The camera calibration method of claim 15, wherein generating a target comprises generating a laser target via a laser device.

18. The camera calibration method of claim 17, wherein said laser device is operable to emit a laser target that comprises at least a pair of intersecting laser lines.

19. The camera calibration method of claim 18, wherein said intersecting laser lines may extend from each of ones center of a respective camera of one said overlapping portion into the overlapping portion.

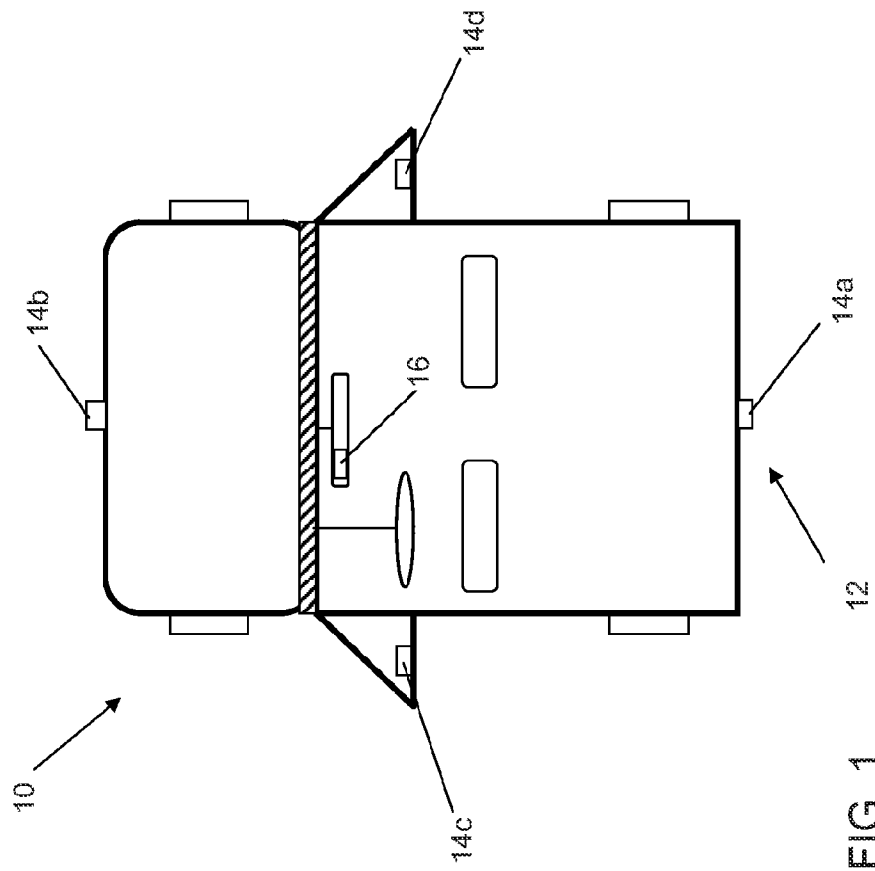

FIG. 1

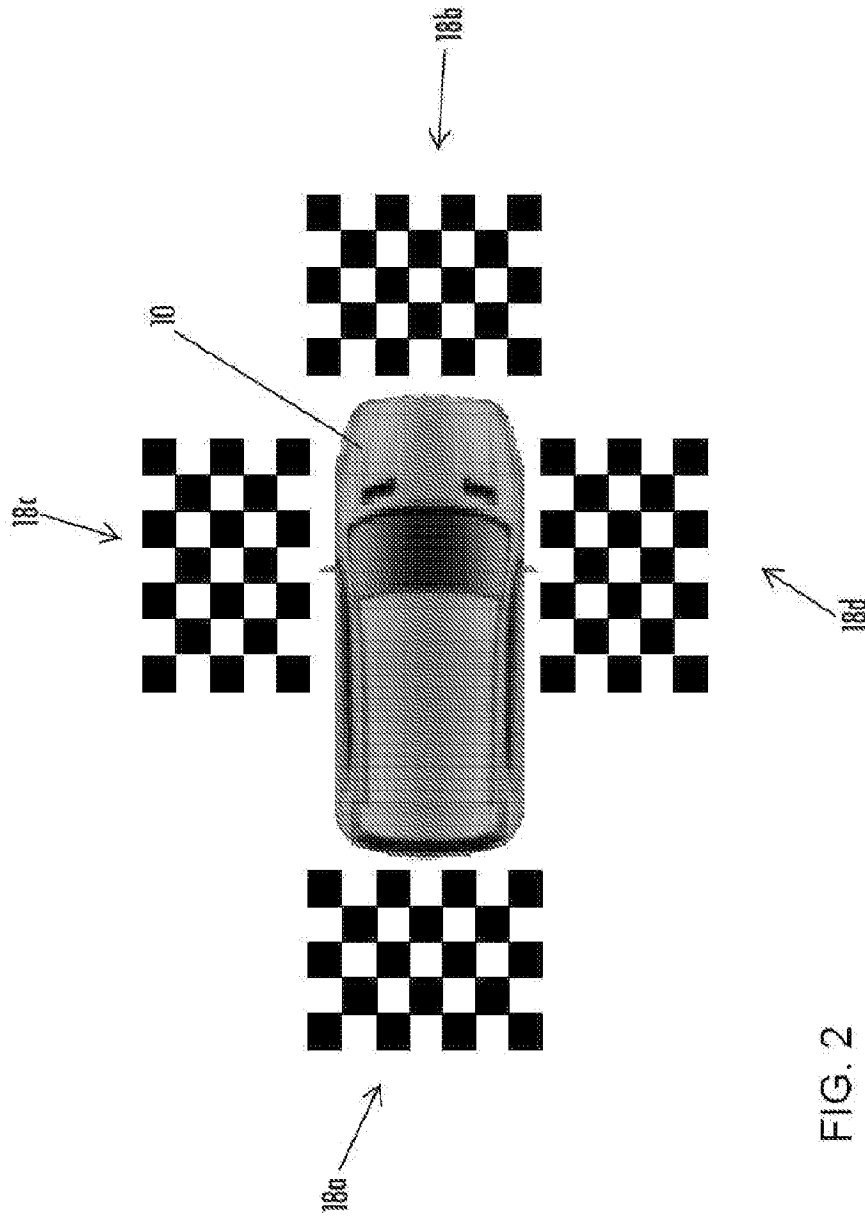
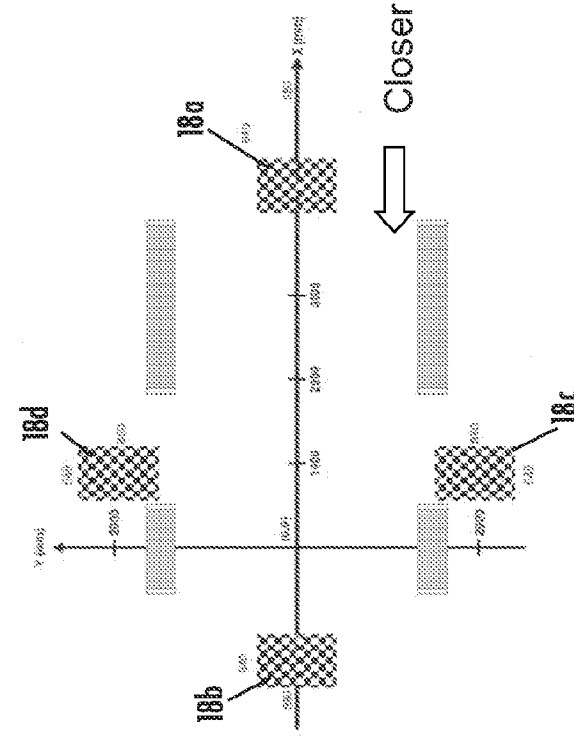

FIG. 2

Calibration target positions for vehicle type B (shorter vehicle type)



Calibration target positions for vehicle type A (longer vehicle type)

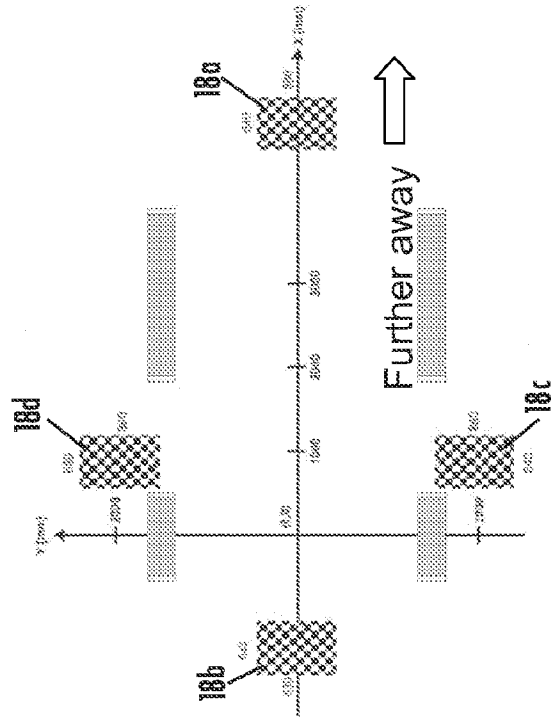

FIG. 4

FIG. 3

- A calibration target will be placed at both calibration target positions
- During calibration of vehicle type A, the calibration target for vehicle type B will be covered by a mechanical cover and visa-versa
- Examples of covering mechanic:
 - Cover frame which moves linear
 - Clapper board which folds over

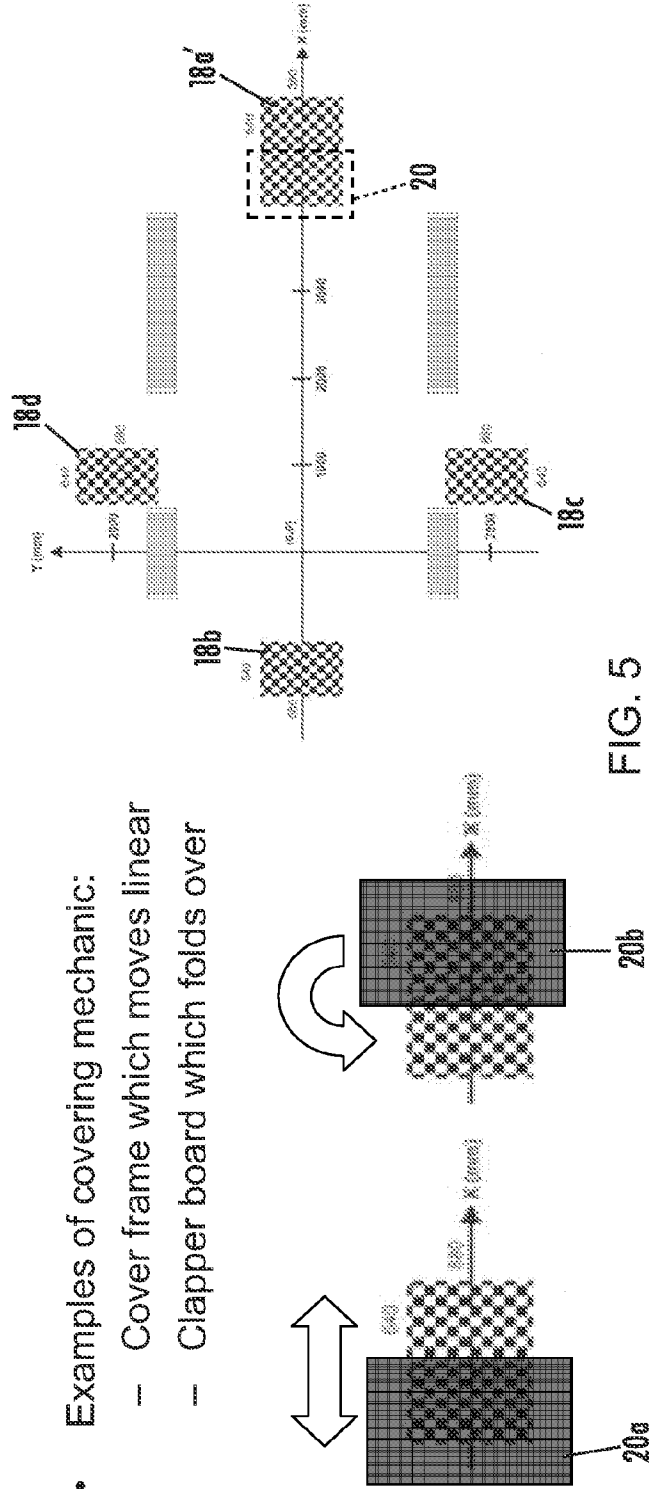
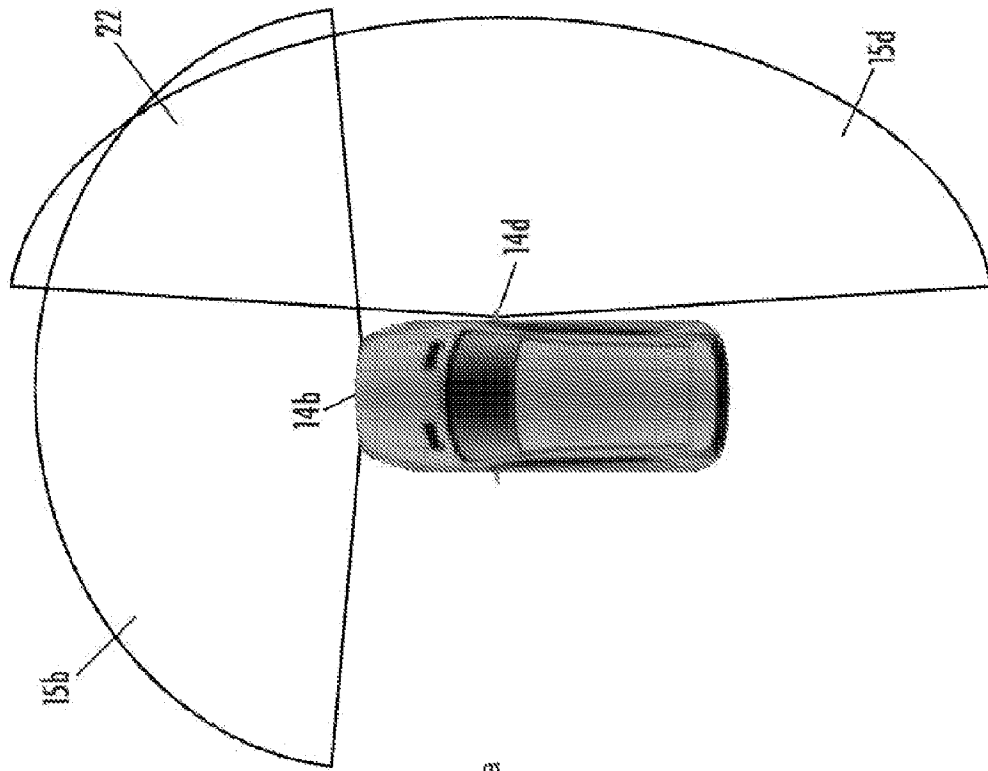
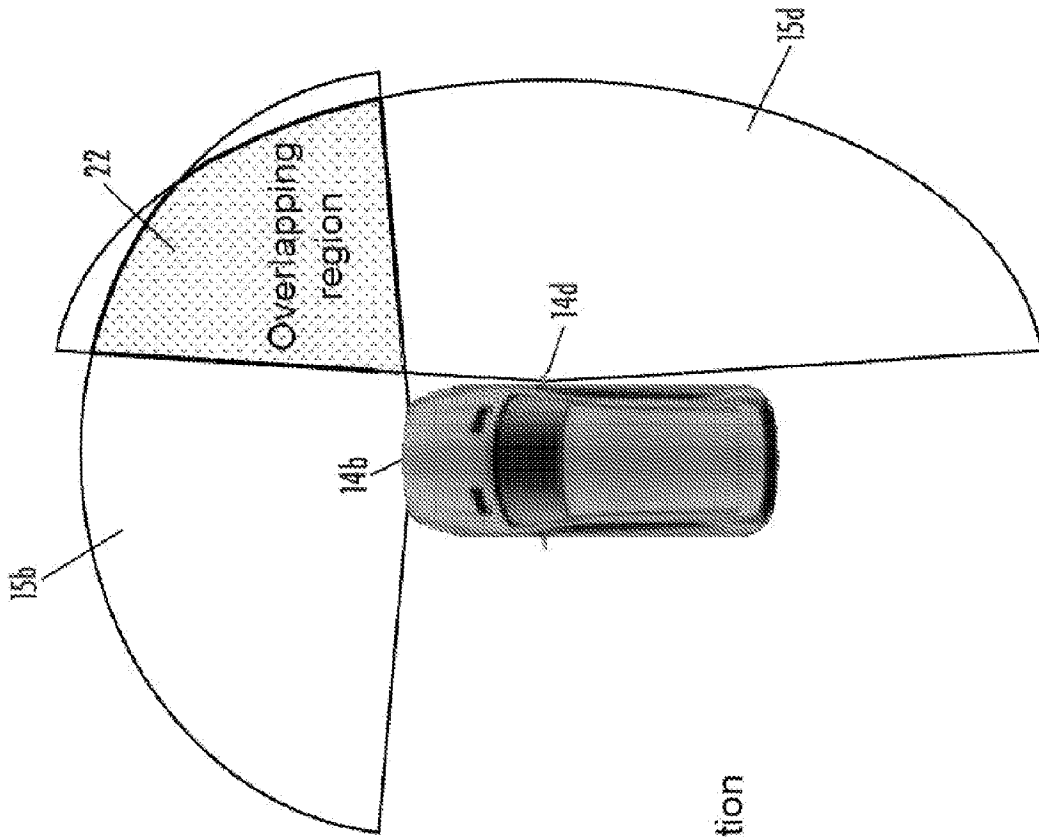

FIG. 5



- Extrinsic calibration of a camera using extrinsic calibrated reference camera

FIG. 6



- Utilizing the overlapping regions between camera images for calibration

FIG. 7

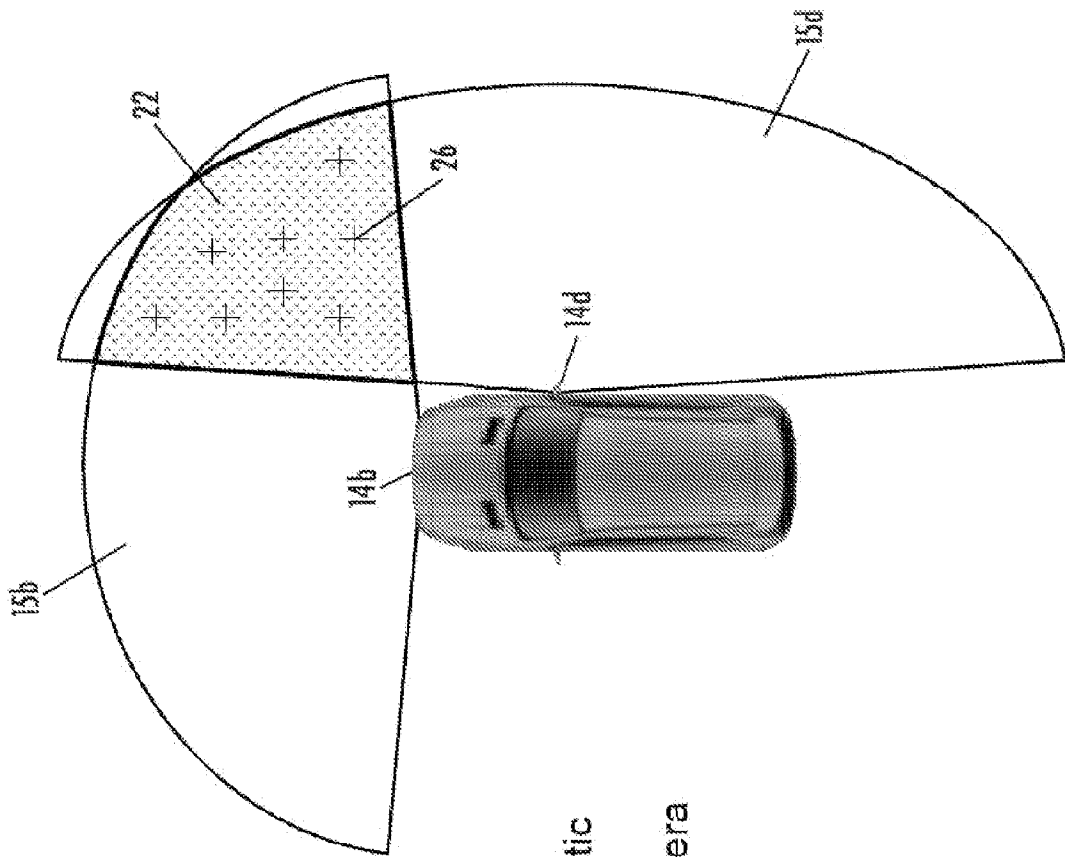

- Detecting characteristic point that could be found in both camera views

FIG. 8

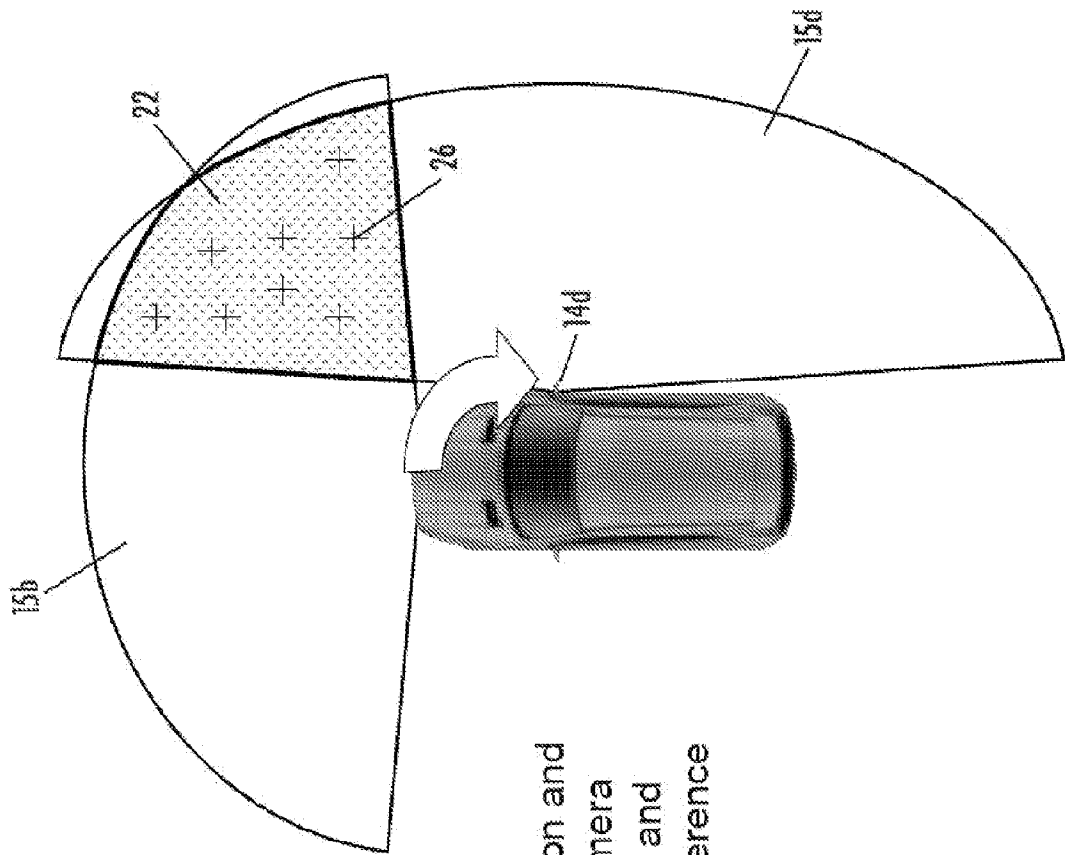

- Fitting camera position and orientation of the camera knowing the position and orientation of the reference camera

FIG. 9

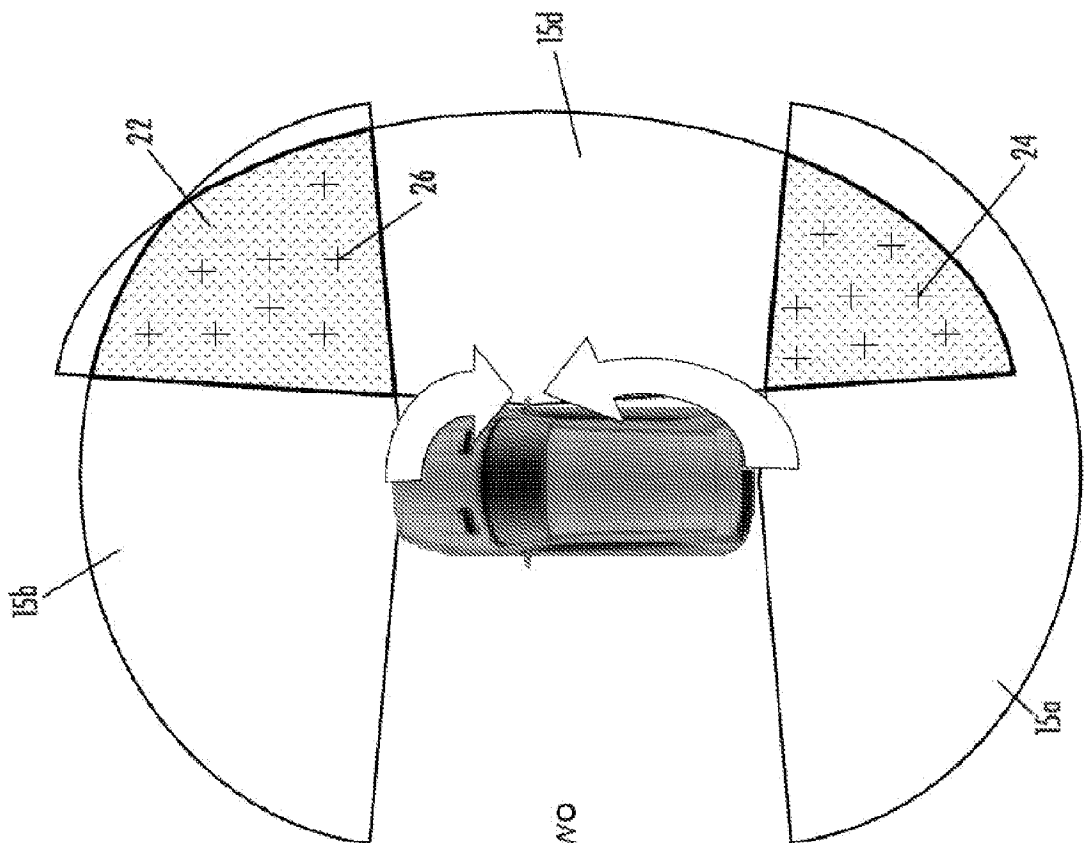

- Accuracy could be increased by using two reference cameras

FIG. 10

10/15

Calibration target by laser pointer

- Utilizing a laser pointer with a point approximating friendly characteristic (e.g. cross, grid lines, etc.);
- To calibrate the camera, the laser point is projected or emitted and moved in the overlap region and the system captures nearly synchronously images from both cameras;
- The system approximates the intersection point with sub pixel precision by fitting complete laser lines and calculate their intersection; and
- After collecting enough point pairs, the system starts extrinsic calculation.
- Point extraction could be improved by pulsing the laser
 - Capture consecutive images with laser enabled and disabled;
 - The subtraction of both images will eliminate static content and will highlight the laser lines;
 - The laser could be synchronized with the image taking or running free with a certain frequency, which is harmonized with the speed of the camera.

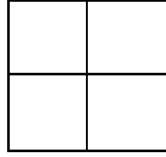

Cross

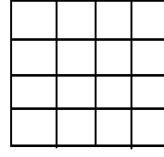

Grid

FIG. 11

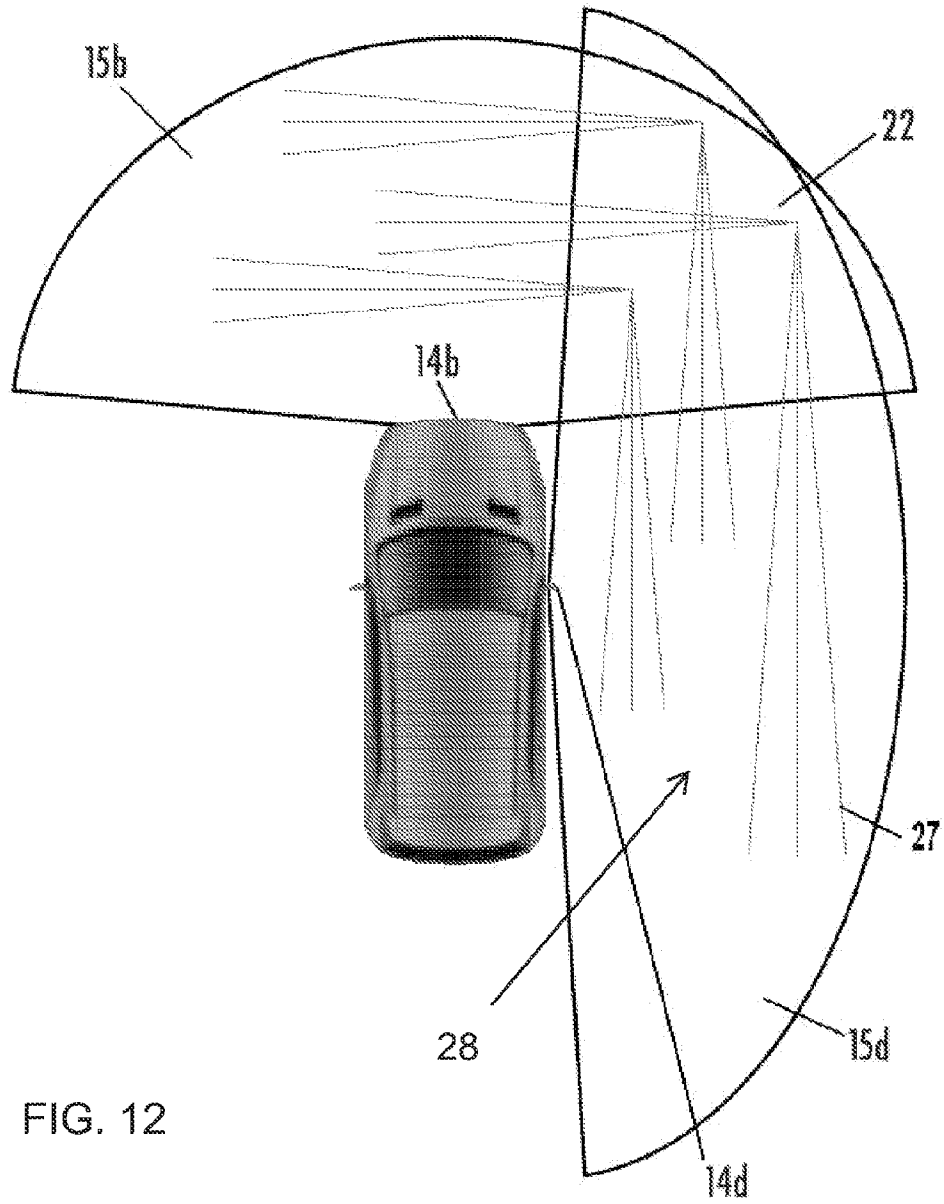

FIG. 12

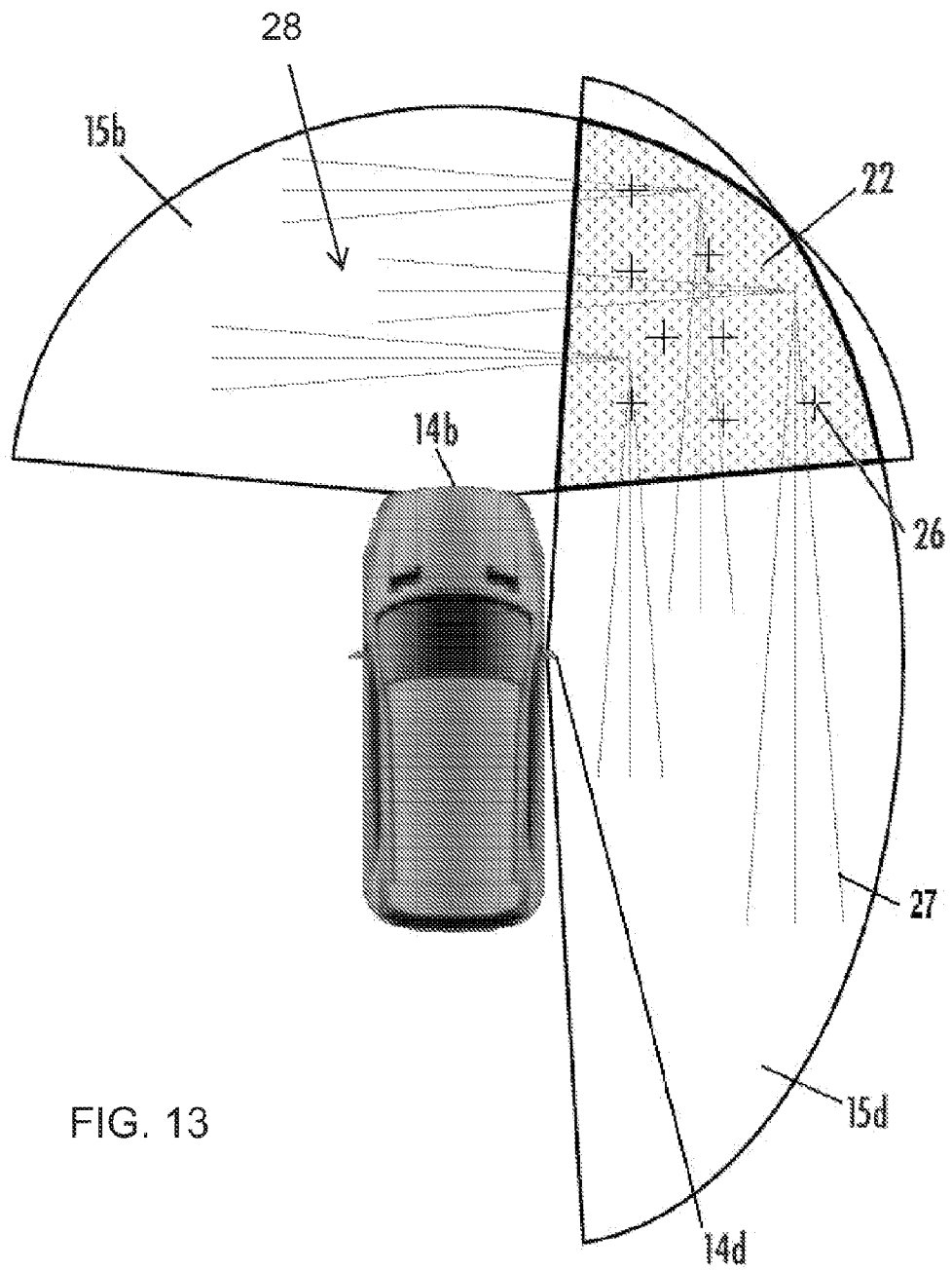

FIG. 13

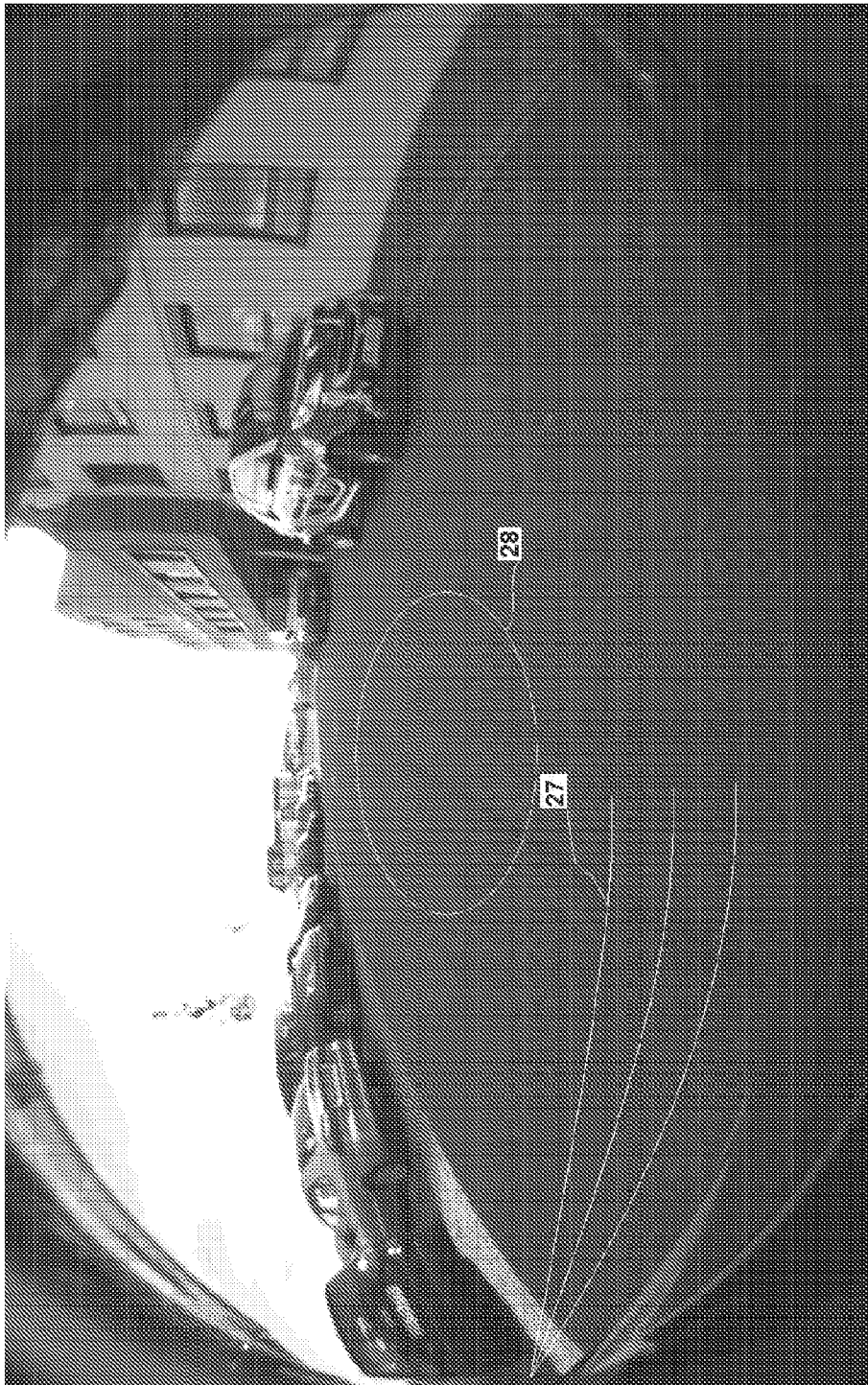

FIG. 14

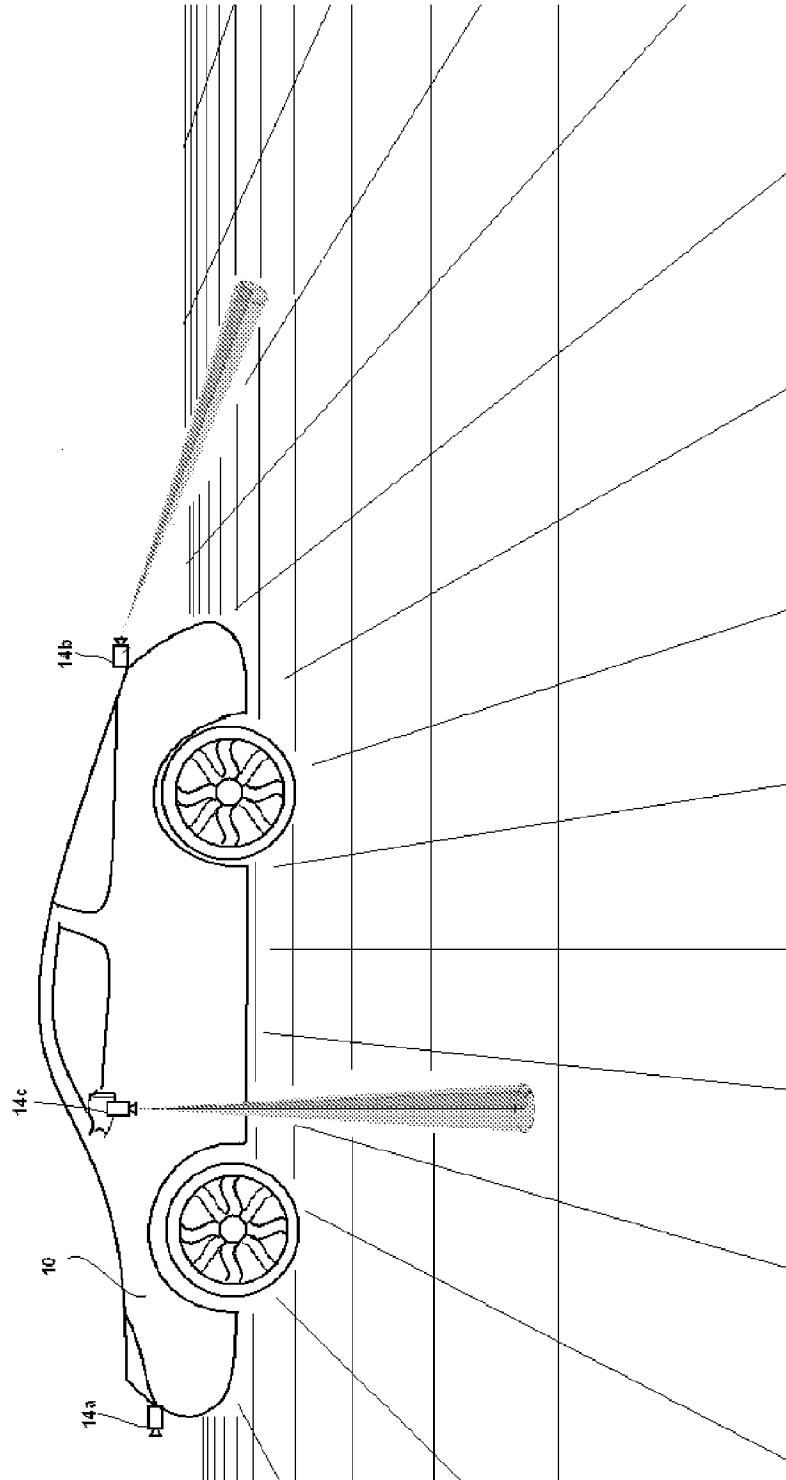

FIG. 15

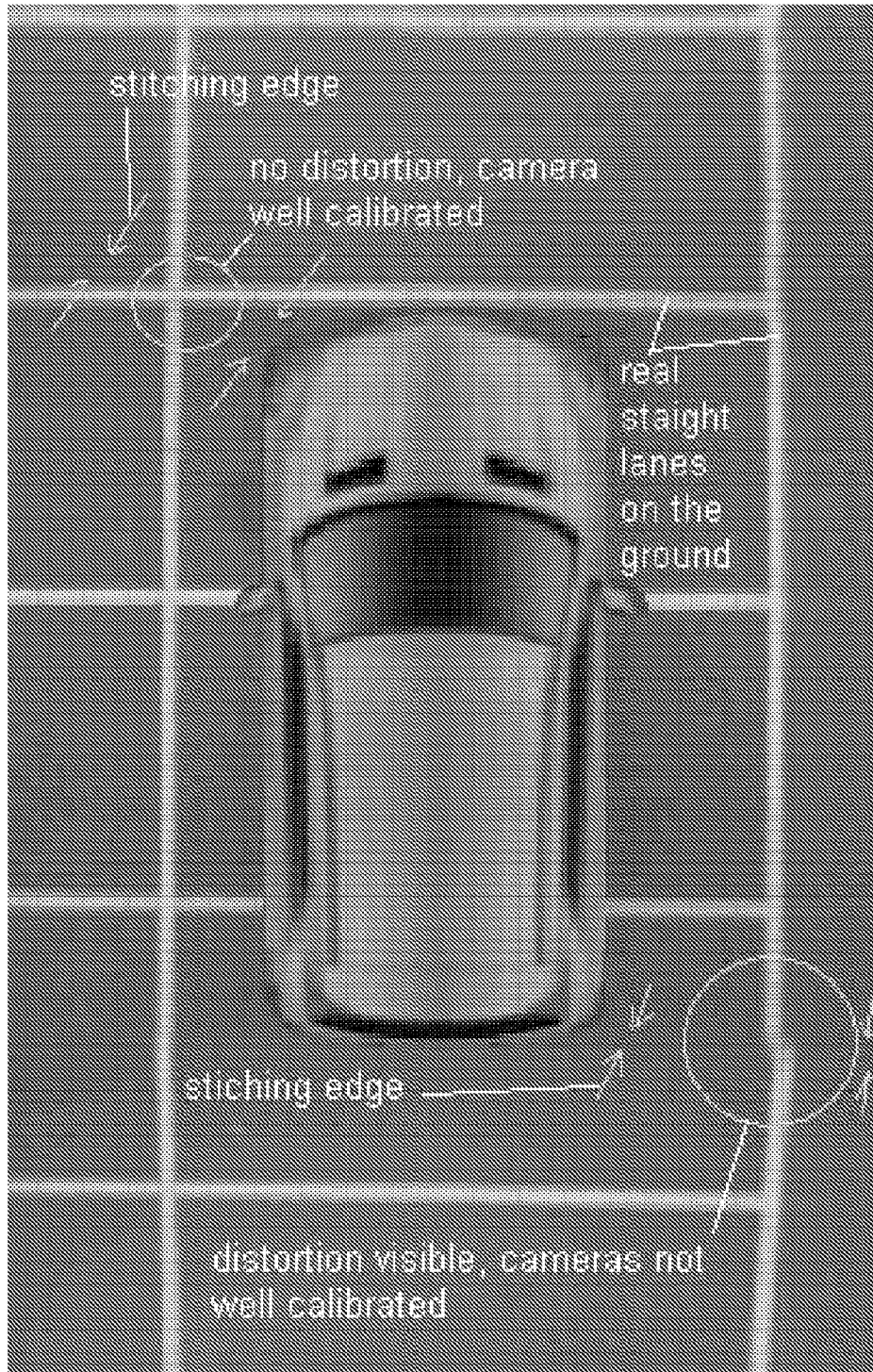

FIG. 16