

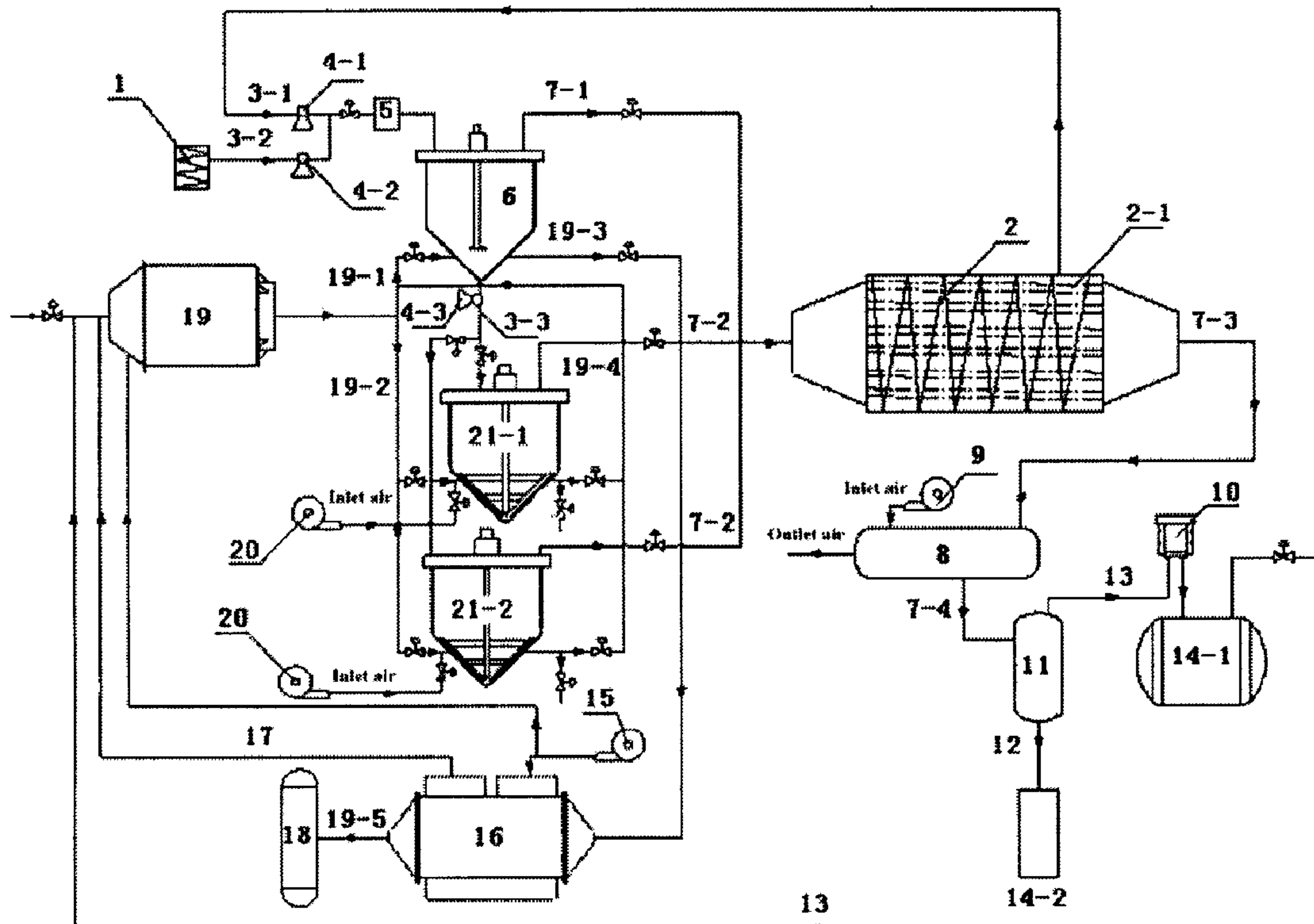

(86) **Date de dépôt PCT/PCT Filing Date:** 2015/02/13
 (87) **Date publication PCT/PCT Publication Date:** 2016/01/07
 (45) **Date de délivrance/Issue Date:** 2019/08/20
 (85) **Entrée phase nationale/National Entry:** 2016/12/23
 (86) **N° demande PCT/PCT Application No.:** CN 2015/072996
 (87) **N° publication PCT/PCT Publication No.:** 2016/000456
 (30) **Priorité/Priority:** 2014/06/30 (CN201410304982.3)

(51) **Cl.Int./Int.Cl. C10G 51/04** (2006.01),
C10G 11/00 (2006.01), **C10G 11/02** (2006.01)
 (72) **Inventeurs/Inventors:**
CAO, ZHIDE, CN;
ZHANG, CHUNWEI, CN;
ZHANG, SHANYIN, CN;
PENG, HONGNA, CN
 (73) **Propriétaire/Owner:**
HUNAN WANTONG TECHNOLOGY CO., LTD., CN
 (74) **Agent:** BCF LLP

(54) **Titre : PROCÉDE DE PREPARATION D'HUILE LEGERE**
 (54) **Title: METHOD FOR PREPARING LIGHT OIL**



(57) **Abrégé/Abstract:**

A method for preparing light oil, comprising the following steps: 1) the visbreaking of heavy oil is performed under stirring to obtain intermediate products, 2) the catalytic cracking of the intermediate products is performed under the effect of stirring and catalyst to obtain the light oil. In the method, the reaction materials are more disperse through stirring, so that the evaporation area of reactant material drip is increased, the production of petroleum coke is reduced, and higher yield of light oil is obtained.

Abstract

A method for preparing light oil, comprising the following steps: 1) the visbreaking of heavy oil is performed under stirring to obtain intermediate products, 2) the catalytic cracking of the intermediate products is performed under the effect of stirring and catalyst to obtain the light oil. In the method, the reaction materials are more disperse through stirring, so that the evaporation area of reactant material drip is increased, the production of petroleum coke is reduced, and higher yield of light oil is obtained.

METHOD FOR PREPARING LIGHT OIL

The present application claims the priority of Chinese Patent Application No.
5 201410304982.3, entitled "METHOD FOR PREPARING LIGHT OIL", filed with
the Chinese State Intellectual Property Office on June 30, 2014.

FIELD OF THE INVENTION

The present invention relates to the refining and petrochemical technical field,
10 and particularly to a method for preparing light oil.

BACKGROUND

Heavy oil refers to crude oil having high asphalt and gum contents as well as a
high viscosity, which has properties of a high viscosity and high freezing point. Due
15 to the properties of the high viscosity and high freezing point, the heavy oil suffers
from some technical difficulties in its application. For example, heavy metals in
heavy oil during a refining process will rapidly reduce the effect of catalyst;
moreover, heavy oil refining produces a large amount of residual oil which has a
high content of stubborn components such as sulfur, nitrogen, metals, acids, etc.,
20 increasing the difficulty in the viscous oil refining. Therefore, modification
treatment on heavy oil and preparation of light oil from heavy oil have become the
focus of attention.

Currently, methods for refining heavy oil to produce light oil mainly include a
solvent deasphalting process, visbreaking process, delayed coking process, catalytic
25 cracking process and hydrogenation process, etc. However, there are some
disadvantages in the light oil preparation using any one of these processes alone, in
which for example, the solvent deasphalting process produces deasphalted oil with a
poor quality; the visbreaking process produces light oil with a poor quality in a low
yield; the delayed coking process suffers from high energy consumption and utilizes
30 hydraulic decoking which is liable to cause environmental contamination; the
catalytic cracking process uses a complex hydrogenation method and suffers from
excessively high plant investments. With respect to the disadvantages of a single
process, many researches have proposed some combined processes in recent years.
For example, Chinese Patent Application No. 00124904.5 discloses a combined

35

9218608.3
34273/16

method of shallow solvent deasphalting and delayed coking, comprising directing a preheated feedstock to be deasphalted together with a solvent into an extraction tower; discharging the deoiled asphalt solution comprising the solvent from the bottom of the extraction tower; directing part of or all of the deasphalted oil after
5 recovery of the solvent, and optionally a conventional feedstock to be coked into a convection section of a delayed coking heating furnace for preheating and entering a radiation section of the heating furnace for heating, followed by entering a coke tower for a coking reaction, with the coke remaining within the coking tower; separating the coked oil and gas to obtain a coked gas, coked gasoline, coked diesel
10 and coked gas oil. Such a method combining a deasphalting process and a delayed coking process provided in the prior art produces light oil in a low yield within a range of 73% to 74%.

SUMMARY OF THE INVENTION

15 In view of this, an object of the present invention is to provide a method for preparing light oil, and the method for preparing light oil provided by the present invention has a high yield.

The present invention provides a method for preparing light oil, comprising the steps of:

20 1) subjecting heavy oil to visbreaking under stirring to obtain an intermediate product; and

2) subjecting the intermediate product to catalytic cracking under stirring in the presence of a catalyst to obtain the light oil.

25 Preferably, the mass ratio of the heavy oil in step 1) to the catalyst in step 2) is (24 to 48):1.

Preferably, the visbreaking in step 1) is performed at a temperature of 240°C to 270°C; and

the visbreaking in step 1) is performed at a pressure of -0.5 KPa to 1.5 KPa.

30 Preferably, the visbreaking in step 1) is performed for a period of 1.5 to 3 hours.

Preferably, the stirring in step 1) is at a speed of 30 to 50 rounds/min; and

the stirring in step 2) is at a speed of 30 to 50 rounds/min.

Preferably, the catalyst in step 2) is a cobalt naphthenate catalyst comprising, in parts by weight:

20 to 35 parts of cobalt naphthenate;

30 to 40 parts of ethylene glycol monomethyl ether;

5 3 to 5 parts of acid activated clay;

10 to 20 parts of glycerol stearate; and

20 to 37 parts of chlorinated paraffin.

Preferably, the catalytic cracking in step 2) is performed at a temperature of 440°C to 470°C.

10 Preferably, the catalytic cracking in step 2) is performed at a pressure of -0.5 KPa to 1.5 KPa.

Preferably, the catalytic cracking in step 2) is performed for a period of 1.5 to 3 hours.

15 Preferably, after completion of the catalytic cracking in step 2), the method further comprises:

cooling the resulting catalytically cracked product at a temperature of 40°C to 50°C to obtain the light oil.

The present invention provides a method for preparing light oil, comprising the steps of: 1) subjecting heavy oil to visbreaking under stirring to obtain an
20 intermediate product; and 2) subjecting the intermediate product to catalytic cracking under stirring in the presence of a catalyst to obtain light oil. In the present invention, the light oil is prepared by combining the visbreaking and catalytic cracking processes which are both performed under stirring. The reaction materials are dispersed through the stirring, so that the evaporation area of droplets of the reaction
25 materials is increased, and thus the surface curvature of the droplets is increased and the vapor pressure of the droplets is thereby increased, which will increase the gasification amount of the reaction materials during the visbreaking and catalytic cracking processes and reduce the output of petroleum coke, thereby improving the yield of the method for preparing light oil of the present invention; therefore, the
30 method for preparing light oil provided according to the present invention has a high yield. Experimental results show that, the method for preparing light oil provided according to the present invention has a yield of 75% to 84%.

In addition, preparation of light oil using a process combining visbreaking and catalytic cracking in the present invention can reduce damage of heavy oil to apparatuses during the light oil preparation.

5 **BRIEF DESCRIPTION OF DRAWINGS**

In order to illustrate embodiments of the present invention and technical solutions in the prior art more clearly, figures necessary to the description of the embodiments and the prior art will be simply introduced hereinafter. Obviously, the figure described below is only for illustration of the present invention, and for those skilled in the art, other figures may be obtained in accordance with the provided figure without any creative work.

Figure 1 is a flow chart of the method for preparing light oil provided in Examples 4 to 6 of the present invention.

15 **DETAILED DESCRIPTION OF THE INVENTION**

The technical solutions in examples of the present invention will be clearly and fully described below, and obviously, the described examples are only parts of embodiments of the present invention rather than all the embodiments thereof. All the other embodiments, which are obtained by those skilled in the art without any creative work based on the embodiments in the present invention, will fall within the scope of the present invention.

The present invention provides a method for preparing light oil, comprising the steps of:

1) subjecting heavy oil to visbreaking under stirring to obtain an intermediate product; and

2) subjecting the intermediate product to catalytic cracking under stirring in the presence of a catalyst to obtain light oil.

In the present invention, the light oil is prepared by combing the visbreaking and catalytic cracking processes which are both performed under stirring. The reaction materials are dispersed through the stirring, so that the evaporation area of droplets of the reaction materials is increased, and thus the surface curvature of the droplets is increased and the vapor pressure of the droplets is thereby increased,

which will increase the gasification amount of the reaction materials during the visbreaking and catalytic cracking processes and reduce the output of petroleum coke, thereby improving the yield of the method for preparing light oil provided according to the present invention; therefore, the method for preparing light oil provided according to the present invention has a high yield. In addition, preparation of light oil using a process combining visbreaking and catalytic cracking in the present invention can reduce damage of heavy oil to apparatuses during the light oil preparation.

In the present invention, the heavy oil is subjected to visbreaking under stirring to obtain an intermediate product. In the present invention, the stirring during the visbreaking is preferably at a speed of 30 to 50 rounds/min, more preferably 35 to 45 rounds/min, and most preferably 40 rounds/min. In the present invention, the heavy oil is dispersed through the stirring, so that the evaporation area of droplets of the heavy oil is increased and thus the vapor pressure of the droplets of the heavy oil is increased, allowing the resulting intermediate product to have a high gas content and a low petroleum coke content and thereby allowing the method for preparing light oil provided according to the present invention to have a high yield.

In the present invention, the visbreaking is preferably performed at a temperature of 240°C to 270°C, and more preferably 250°C to 260°C. The heating apparatus used for the visbreaking to reach the desired temperature is not particularly limited in the present invention, as long as the heating apparatus is well known to those skilled in the art, and in embodiments of the present invention, it may be a flue gas furnace. It is preferred in the present invention that the residual energy after heating in the visbreaking is converted into a new thermal energy to improve the energy availability of the method for preparing light oil provided according to the present invention. For example, in an embodiment of the present invention, after heating in the visbreaking with a medium-temperature flue gas, the medium-temperature flue gas turns into a medium-temperature waste flue gas which may be flowed into a heat exchanger for heat exchange with cold air, and the resulting hot air flow is flowed into the flue gas furnace for aiding combustion, in which the medium-temperature flue gas in the present invention is preferably at a temperature of 500°C to 700°C, more preferably 550°C to 650°C; and the medium-temperature waste flue gas in the present invention is preferably at a temperature of 200°C to 350°C, more preferably 200°C to 300°C. In the present

invention, it is preferred to recycle and treat the waste gas produced during the energy use, making the method for preparing light oil provided according to the present invention more environmentally friendly. For example, in an embodiment of the present invention, after the heat exchange between the medium-temperature waste flue gas and cold air, the resulting normal-temperature waste flue gas is recycled in a denitration and desulphurization device, in which the normal-temperature waste flue gas in the present invention is preferably at a temperature of 20°C to 30°C, more preferably 23°C to 28°C.

In the present invention, the visbreaking is preferably performed at a pressure of -0.5 KPa to 1.5 KPa, more preferably -0.8 KPa to 1.2 KPa, most preferably 1 KPa. In the present invention, the visbreaking is preferably performed for a period of 1.5 to 3 hours, more preferably 2 to 2.5 hours.

Prior to the visbreaking of the heavy oil, it is preferred in the present invention to preheat the heavy oil. In the present invention, the heavy oil is preferably preheated to a temperature of 50°C to 95°C, more preferably 60°C to 80°C, and most preferably 65°C to 75°C.

The types and sources of the heavy oil are not particularly limited in the present invention, as long as it is heavy oil well known to those skilled in the art, and the heavy oil may be available from market. In the present invention, the heavy oil preferably has a viscosity of 100 mPa·s to 1000 mPa·s, more preferably 300 mPa·s to 800 mPa·s, and most preferably 500 mPa·s to 600 mPa·s. In the present invention, the heavy oil produces medium-temperature oil and gas during the visbreaking, in which the medium-temperature oil and gas are preferably at a temperature of 240°C to 270°C, more preferably 250°C to 260°C. It is preferred in the present invention that the medium-temperature oil and gas are collected to reduce foams in the intermediate product of the above technical solutions.

In the present invention, after the intermediate product is obtained, the intermediate product is subjected to catalytic cracking under stirring in the presence of a catalyst to obtain light oil. It is preferred in the present invention that the catalyst is added during the visbreaking as described in the above technical solutions such that the catalyst exerts a better effect. It is preferred in the present invention that the catalyst and heavy oil are subjected to visbreaking under stirring to obtain the intermediate product. In the present invention, the stirring during the catalytic cracking is preferably at a speed of 30 to 50 rounds/min, more preferably 35 to 45 rounds/min, and most preferably 40 rounds/min. In the present invention, liquid in

the intermediate product as described above is dispersed through the stirring, so that the evaporation area of the liquid droplets in the intermediate product is increased and thus the vapor pressure of the liquid droplets in the intermediate product is increased, which would allow more oil and gas to be produced in the catalytic cracking process and thereby reduce the output of petroleum coke and further improve the yield of the method for preparing light oil provided according to the present invention.

In the present invention, the catalytic cracking is preferably performed at a temperature of 440°C to 470°C, and more preferably 450°C to 460°C. The heating apparatus used for the catalytic cracking to reach the desired temperature is not particularly limited in the present invention, as long as it is a heating apparatus well known to those skilled in the art, and in embodiments of the present invention it may be a flue gas furnace. The temperature of the flue gas furnace in the present invention may be adjusted by heating with flue gases having different temperatures. In the present invention, the residual energy after heating in the catalytic cracking is preferably used as an energy for heating in the visbreaking as described above, so as to achieve reasonable utilization of the thermal energy in the process of preparing light oil according to the present invention. For example, in an embodiment of the present invention, after heating in the catalytic cracking with a high-temperature flue gas, the high-temperature flue gas turns into a high-temperature waste flue gas and the waste heat in the high-temperature waste flue gas may be used to heat in the visbreaking, in which the high-temperature flue gas in the present invention is preferably at a temperature of 700°C to 1200°C, more preferably 800°C to 1100°C; and the high-temperature waste flue gas in the present invention is preferably at a temperature of 500°C to 800°C, more preferably 600°C to 700°C.

In the present invention, the catalytic cracking is preferably performed at a pressure of -0.5 KPa to 1.5 KPa, more preferably -0.8 KPa to 1.2 KPa, and most preferably 1 KPa. In the present invention, the catalytic cracking is preferably performed for a period of 1.5 to 3 hours, more preferably 2 to 2.5 hours.

The types and sources of the catalyst are not particularly limited in the present invention, as long as it is a catalyst for catalytic cracking well known to those skilled in the art, and the catalyst may be available from market or may be prepared. In the present invention, the catalyst is preferably a cobalt naphthenate catalyst comprising, in parts by weight, 20 to 35 parts of cobalt naphthenate, 30 to 40 parts of ethylene glycol monomethyl ether, 3 to 5 parts of acid activated clay, 10 to 20 parts of

glycerol stearate, 20 to 37 parts of chlorinated paraffin. The catalytic cracking in the present invention is performed by using the cobalt naphthenate catalyst which has a better catalytic effect and is able to further improve the yield of the method for preparing light oil provided according to the present invention. In the present invention, the cobalt naphthenate catalyst is a catalyst disclosed in Chinese Patent Application No. 200510126073.6, and can be prepared in accordance with the method as disclosed in the Chinese Patent Application No. 200510126073.6.

In the present invention, high-temperature oil and gas are produced during the catalytic cracking, which are cooled in the present invention to result in light oil. In the present invention, the high-temperature oil and gas are preferably at a temperature of 440°C to 470°C, and more preferably 450°C to 460°C. In the present invention, the high-temperature oil and gas during the catalytic cracking are preferably cooled to a temperature of 40°C to 50°C, more preferably to 42°C to 47°C. It is preferred in the present invention that the medium-temperature oil and gas as well as the high-temperature oil and gas as described in the above technical solutions are cooled after they are mixed together, to obtain the light oil. The apparatus for cooling the high-temperature oil and gas is not particularly limited in the present invention, as long as it is a condenser well known to those skilled in the art.

In the present invention, a dry gas may be obtained in addition to the light oil after the high-temperature oil and gas are cooled. It is preferred in the present invention that the light oil is separated from the dry gas and the dry gas is used as a fuel for heating in the visbreaking and catalytic cracking in the above technical solutions to reduce the cost of the method for preparing light oil provided according to the present invention. The apparatus for separating the light oil from the dry gas is not particularly limited in the present invention, as long as it is a separator well known to those skilled in the art. In the present invention, the separator is preferably a cyclone separator. In the present invention, the separator is preferably equipped with a mist trap. In the present invention, the separator equipped with a mist trap is capable of separating the light oil from dry gas better and preventing the separated dry gas from carrying the light oil.

In order to improve the production efficiency of the method for preparing light oil provided according to the present invention, the above catalytic cracking operation may be performed simultaneously in a plurality of catalytic cracking devices in the present invention. The apparatus for the catalytic cracking is not particularly limited in the present invention, as long as it is a catalytic cracking

apparatus well known to those skilled in the art, such as a reaction tank. In an embodiment of the present invention, two reaction tanks may be provided to simultaneously carry out the catalytic cracking in the above technical solutions.

In the present invention, petroleum coke is produced during the catalytic cracking. It is preferred in the present invention that the petroleum coke is removed. In the present invention, a method for removing the petroleum coke is mechanical decoking to avoid environmental contamination caused by hydraulic decoking. In the present invention, an apparatus for the mechanical decoking is preferably a decoking device disclosed in Chinese Patent Application No. 201310293933.X. Prior to removal of the petroleum coke, it is preferred in the present invention that the petroleum coke is subjected to a temperature-fall treatment with a temperature-fall temperature of 200°C to 350°C. In the present invention, the temperature-fall temperature of the petroleum coke is more preferably 220°C to 250°C. The apparatus for the temperature-fall treatment on the petroleum coke is not particularly limited in the present invention, and it may be a cooling fan.

Figure 1 is a flow chart of the method for preparing light oil provided in Examples 4 to 6 of the present invention, in which 1 denotes a catalyst heat tracing tank, 2 denotes feedstock pool, 2-1 denotes an oil and gas pipeline, 3-1 denotes heavy oil, 3-2 denotes catalyst, 3-3 denotes intermediate product, 4-1 denotes heavy oil pump, 4-2 denotes catalyst pump, 4-3 denotes a high temperature pump, 5 denotes mixing device, 6 denotes primary reaction tank, 7-1 denotes medium-temperature oil and gas, 7-2 denotes high-temperature oil and gas, 7-3 denotes mixed gas of high-temperature oil and gas and medium-temperature oil and gas, 7-4 denotes mixture of light oil and dry gas, 8 denotes condenser, 9 denotes condenser fan, 10 denotes high pressure fan, 11 denotes separator, 12 denotes light oil, 13 denotes dry gas, 14-1 denotes dry gas holder, 14-2 denotes oil storage barrel, 15 denotes centrifugal fan, 16 denotes heat exchanger, 17 denotes hot air, 18 denotes denitration and desulphurization device, 19 denotes flue gas furnace, 19-1 denotes medium-temperature flue gas, 19-2 denotes high-temperature flue gas, 19-3 denotes medium-temperature waste flue gas, 19-4 denotes high-temperature waste flue gas, 19-5 denotes normal-temperature waste flue gas, 20 denotes cooling fan, 21-1 denotes No. 1 secondary reaction tank and 21-2 denotes No. 2 secondary reaction tank. The light oil is prepared in accordance with the procedures as shown in Figure 1 which specifically as follows.

A device for heating catalyst the heat tracing tank 1 and feedstock pool 2 is

initiated to pretreat the catalyst 3-2 and heavy oil 3-1 to a temperature of 50°C to 95°C. The catalyst 3-2 is transported through the catalyst pump 4-2 into the mixing device 5, and the heavy oil 3-1 is transported through the heavy oil pump 4-1 into the mixing device 5; in the mixing device 5 the catalyst 3-1 and the heavy oil 3-2 are
5 mixed uniformly and transported into the primary reaction tank 6 for visbreaking, wherein the catalyst pump 4-2 and the heavy oil pump 4-1 both have a metering function to allow the mass ratio of the heavy oil 3-1 to the catalyst 3-2 to be (24 to 48):1. In the present invention, the types and sources of the heavy oil 3-1 and catalyst 3-2 are in consistent with the types and sources of the heavy oil and catalyst
10 in the above technical solutions, and are not repeated here.

The flue gas furnace 19 is initiated to produce medium-temperature flue gas 19-1, which enters a heating cavity of the primary reaction tank 6, wherein the medium-temperature flue gas 19-1 is at a temperature of 500°C to 700°C. A stirring device within the primary reaction tank 6 is initiated to perform visbreaking of the
15 heavy oil and catalyst in the primary reaction tank 6 at a temperature of 240°C to 270°C for 1.5 to 3 hours under a stirring speed of 30 to 50 rounds/min, with the pressure within the primary reaction tank 6 set at -0.5 KPa to 1.5 KPa. During the process of the visbreaking, the generated medium-temperature oil and gas 7-1 escapes from the primary reaction tank 6 and enters the oil and gas pipeline 2-1 in
20 the feedstock pool 2, wherein the medium-temperature oil and gas 7-1 is at a temperature of 240°C to 270°C. An intermediate product 3-3 obtained after completion of the visbreaking is transported through the high temperature pump 4-3 into No. 1 secondary reaction tank 21-1. The medium-temperature flue gas 19-1 is discharged from the primary reaction tank 6 and forms medium-temperature waste
25 flue gas 19-3 which enters the heat exchanger 16 for heat exchange with cold air to result in hot air 17, which is transferred into the flue gas furnace 19 for aiding combustion, wherein the medium-temperature waste flue gas 19-3 is at a temperature of 200°C to 350°C. A normal-temperature waste flue gas 19-5 obtained after the heat exchange between the medium-temperature waste flue gas 19-3 and
30 cold air is sent into the denitration and desulphurization device 18 for recycling, wherein the normal-temperature waste flue gas 19-5 is at a temperature of 20°C to 30°C.

The temperature of the flue gas furnace 19 is adjusted to produce the high-temperature flue gas 19-2 which enters a heating cavity of the No. 1 secondary
35 reaction tank 21-1, wherein the high-temperature flue gas 19-2 is at a temperature of

700°C to 1200°C. A stirring device in the No. 1 secondary reaction tank 21-1 is initiated to perform catalytic cracking of the intermediate product at a temperature of 440°C to 470°C for 1.5 to 3 hours under a stirring speed of 30 to 50 rounds/min, with the pressure within the No. 1 secondary reaction tank 21-1 set at -0.5 KPa to 1.5 KPa.

5 During the process of the catalytic cracking, the generated high-temperature oil and gas 7-2 escape from the No. 1 secondary reaction tank and flows into the oil and gas pipeline 2-1 in the feedstock pool 2, wherein the high-temperature oil and gas 7-2 are at a temperature of 440°C to 470°C. The high-temperature flue gas 19-2 flows out of the heating cavity of the No. 1 secondary reaction tank and then forms the

10 high-temperature waste flue gas 19-4 which is transported to the heating cavity of the primary reaction tank 6, to provide the thermal energy for the visbreaking as described above with the residual heat of the high-temperature waste flue gas 19-4, wherein the high-temperature waste flue gas 19-4 is at a temperature of 500°C to 800°C.

15 The medium-temperature oil and gas 7-1 and the high-temperature oil and gas 7-2 are mixed within the oil and gas pipeline 2-1 in the feedstock pool 2 to produce a mixed gas 7-3 of the high-temperature oil and gas and the medium-temperature oil and gas, which is cooled in a condenser 8 by initiating the condenser fan 9, wherein the cooling temperature is 40°C to 50°C, and after the cooling of the mixed gas 7-3

20 of the high-temperature oil and gas and the medium-temperature oil and gas, a mixture 7-4 of light oil and dry gas is obtained. A high pressure fan 10 is initiated to separate the mixture 7-4 of the light oil and the dry gas in a separator 11, producing the light oil 12 and the dry gas 13, in which the light oil 12 is sent into an oil storage tank 14-2 and the dry gas 13 is sent into a dry gas holder 14-1. When the output of

25 the dry gas 13 is constant, the dry gas in the dry gas holder 14-1 is sent into the flue gas furnace 19 to supply heat for combustion.

After all the high-temperature oil and gas 7-2 produced during the catalytic cracking process within the No. 1 secondary reaction tank 21-1 enters the oil and gas pipeline 2-1, a cooling fan 20 is initiated to supply air into the heating cavity of the

30 No. 1 secondary reaction tank 21-1, thereby cooling the petroleum coke produced in the catalytic cracking process to a temperature of 200°C to 350°C; and the mechanical decoking device is initiated to discharge the petroleum oil.

When the catalytic cracking is performed in the No. 1 secondary reaction tank 21-1, the intermediate product 3-3 obtained in the primary reaction tank 6 is

35 transported into No. 2 secondary reaction tank 21-2 where the catalytic cracking is

repeated as described above to prepare light oil.

According to the output of the obtained light oil as well as the mass of the heavy oil used for preparing the light oil, the yield of the method for preparing light oil provided according to the present invention is calculated, and the calculated
5 result indicates that the method for preparing light oil provided according to the present invention has a yield of 75% to 84%, which is high.

The present invention provides a method for preparing light oil, comprising the steps of: 1) subjecting heavy oil to visbreaking under stirring to obtain an intermediate product; and 2) subjecting the intermediate product to catalytic
10 cracking under stirring in the presence of a catalyst to obtain light oil. In the present invention, the light oil is prepared by combining the visbreaking and catalytic cracking processes which are both performed under stirring, and the reaction materials are dispersed through the stirring, so that the evaporation area of droplets of the reaction
15 materials is increased, and thus the surface curvature of the droplets is increased and the vapor pressure of the droplets is thereby increased, which will increase the gasification amount of the reaction materials during the visbreaking and catalytic cracking processes and reduce the output of petroleum coke, thereby improving the
20 yield of the method for preparing light oil provided according to the present invention; therefore, the method for preparing light oil provided according to the present invention has a high yield. In addition, preparation of light oil using a process combining visbreaking and catalytic cracking in the present invention can reduce damage of heavy oil to apparatuses during the light oil preparation.

For further understanding the present invention, the method for preparing light oil provided according to the present invention will be described in detail hereinafter
25 in conjunction with examples, but these examples should not be construed as limiting the protection scope of the present invention.

All the raw materials used in the following examples of the present invention are commercially available products.

EXAMPLE 1

30 25 kg cobalt naphthenate, 40 kg ethylene glycol monomethyl ether, 5 kg acid activated clay, 10 kg glycerol stearate and 20 kg chlorinated paraffin 70 were mixed uniformly to obtain a catalyst, in which the acid activated clay was obtained by mixing sulfuric acid with a 98% mass concentration and clay at a mass ratio of 1:49.

EXAMPLE 2

20 kg cobalt naphthenate, 30 kg ethylene glycol monomethyl ether, 3 kg acid activated clay, 20 kg glycerol stearate and 27 kg chlorinated paraffin 70 were mixed uniformly to obtain a catalyst, in which the acid activated clay was obtained by
5 mixing sulfuric acid with a 98% mass concentration and clay at a mass ratio of 1:49.

EXAMPLE 3

20 kg cobalt naphthenate, 30 kg ethylene glycol monomethyl ether, 3 kg acid activated clay, 10 kg glycerol stearate and 37 kg chlorinated paraffin 70 were mixed uniformly to obtain a catalyst, in which the acid activated clay was obtained by
10 mixing sulfuric acid with a 98% mass concentration and clay at a mass ratio of 1:49.

EXAMPLE 4

Light oil was prepared in accordance with the procedure shown in Figure 1, and Figure 1 is a flow chart of the method for preparing light oil provided in Examples 4 to 6 of the present invention, which was specifically as follows.

15 A device for heating catalyst heat tracing tank 1 and feedstock pool 2 was initiated to pretreat catalyst 3-2 and heavy oil 3-1 to a temperature of 50°C, in which the catalyst 3-2 was the catalyst prepared in EXAMPLE 1. The catalyst 3-2 was transported through a catalyst pump 4-2 into a mixing device 5, and the heavy oil 3-1 was transported through a heavy oil pump 4-1 into the mixing device 5; in the
20 mixing device 5 the catalyst 3-1 and the heavy oil 3-2 were mixed uniformly and transported into a primary reaction tank 6 for visbreaking, wherein the catalyst pump 4-2 and the heavy oil pump 4-1 both had a metering function to allow that the dosage of the heavy oil 3-1 was 98 kg and the dosage of the catalyst 3-2 was 2 kg.

A flue gas furnace 19 was initiated to produce medium-temperature flue gas
25 19-1 which entered a heating cavity of the primary reaction tank 6, wherein the medium-temperature flue gas 19-1 was at a temperature of 500°C. A stirring device within the primary reaction tank 6 was initiated to perform visbreaking of the heavy oil and catalyst in the primary reaction tank 6 at a temperature of 240°C for 1.5 hours under a stirring speed of 30 rounds/min, with the pressure within the primary
30 reaction tank 6 set at -0.5 KPa. During the process of the visbreaking, the generated medium-temperature oil and gas 7-1 escaped from the primary reaction tank 6 and entered an oil and gas pipeline 2-1 in the feedstock pool 2, wherein the medium-temperature oil and gas 7-1 was at a temperature of 240°C. The

intermediate product 3-3 obtained after completion of the visbreaking was transported through a high temperature pump 4-3 into No. 1 secondary reaction tank 21-1. The medium-temperature flue gas 19-1 was discharged from the primary reaction tank 6 and formed medium-temperature waste flue gas 19-3 which entered a
5 heat exchanger 16 for heat exchange with cold air, to obtain hot air 17, which was transferred into the flue gas furnace 19 for aiding combustion, wherein the medium-temperature waste flue gas 19-3 was at a temperature of 200°C. A normal-temperature waste flue gas 19-5 obtained after the heat exchange between
10 the medium-temperature waste flue gas 19-3 and cold air was transferred into a denitration and desulphurization device 18 for recycling, wherein the normal-temperature waste flue gas 19-5 was at a temperature of 20°C.

The temperature of the flue gas furnace 19 was adjusted to produce high-temperature flue gas 19-2 which entered a heating cavity of the No. 1 secondary reaction tank 21-1, wherein the high-temperature flue gas 19-2 was at a
15 temperature of 700°C. A stirring device in the No. 1 secondary reaction tank 21-1 was initiated to perform catalytic cracking of the intermediate product 3-3 at a temperature of 440°C for 2 hours under a stirring speed of 40 rounds/min, with the pressure within the No. 1 secondary reaction tank 21-1 set at 1 KPa. During the process of the catalytic cracking, the generated high-temperature oil and gas 7-2
20 escaped from the No. 1 secondary reaction tank and flowed into the oil and gas pipeline 2-1 in the feedstock pool 2, wherein the high-temperature oil and gas 7-2 was at a temperature of 440°C. The high-temperature flue gas 19-2 flowed out of the heating cavity of the No. 1 secondary reaction tank 21-1 and then formed high-temperature waste flue gas 19-4 which was transported to the heating cavity of
25 the primary reaction tank 6, to provide the thermal energy for the visbreaking as described above with the residual heat of the high-temperature waste flue gas 19-4, wherein the high-temperature waste flue gas 19-4 was at a temperature of 500°C.

The medium-temperature oil and gas 7-1 and the high-temperature oil and gas 7-2 were mixed within the oil and gas pipeline 2-1 in the feedstock pool 2 to
30 produce a mixed gas 7-3 of the high-temperature oil and gas and the medium-temperature oil and gas, which was cooled in a condenser 8 by initiating a condenser fan 9, wherein the cooling temperature was 50°C, and after the cooling of the mixed gas 7-3 of the high-temperature oil and gas and the medium-temperature oil and gas, a mixture 7-4 of light oil and dry gas was obtained. A high pressure fan
35 10 was initiated to separate the mixture 7-4 of the light oil and the dry gas in a

separator 11, producing the light oil 12 and the dry gas 13, in which the light oil 12 was sent into an oil storage tank 14-2 and the dry gas 13 was sent into a dry gas holder 14-1. When the output of the dry gas 13 was constant, the dry gas in the dry gas holder 14-1 was sent into the flue gas furnace 19 to supply heat for combustion.

5 After all the high-temperature oil and gas 7-2 produced during the catalytic cracking process within the No. 1 secondary reaction tank 21-1 entered the oil and gas pipeline 2-1, a cooling fan 20 was initiated to supply air into the heating cavity of the No. 1 secondary reaction tank 21-1, thereby cooling the petroleum coke produced in the catalytic cracking process to a temperature of 200°C; and a
10 mechanical decoking device was initiated to discharge the petroleum oil.

When the catalytic cracking was performed in the No. 1 secondary reaction tank 21-1, the intermediate product 3-3 obtained in the primary reaction tank 6 was transported into No. 2 secondary reaction tank 21-2 where the catalytic cracking was repeated as described above to prepare light oil.

15 According to the method as described in the above embodiment, the yield of the method for preparing light oil provided in EXAMPLE 4 of the present invention was calculated, and the calculated result indicated that the yield of the method for preparing light oil provided in EXAMPLE 4 of the present invention was 75.3%, which was high.

20 EXAMPLE 5

Light oil was prepared in accordance with the procedure shown in Figure 1, which was specifically as follows.

A device for heating a catalyst heat tracing tank 1 and feedstock pool 2 was initiated to pretreat catalyst 3-2 and heavy oil 3-1 to a temperature of 95°C, in which
25 the catalyst 3-2 was the catalyst prepared in EXAMPLE 2. The catalyst 3-2 was transported through a catalyst pump 4-2 into a mixing device 5, and the heavy oil 3-1 was transported through a heavy oil pump 4-1 into the mixing device 5; in the mixing device 5 the catalyst 3-1 and the heavy oil 3-2 were mixed uniformly and transported into a primary reaction tank 6 for visbreaking, wherein the catalyst pump
30 4-2 and the heavy oil pump 4-1 both had a metering function to allow that the dosage of the heavy oil 3-1 was 96 kg and the dosage of the catalyst 3-2 was 4 kg.

A flue gas furnace 19 was initiated to produce medium-temperature flue gas 19-1 which entered a heating cavity of the primary reaction tank 6, wherein the

medium-temperature flue gas 19-1 was at a temperature of 700°C. A stirring device within the primary reaction tank 6 was initiated to perform visbreaking of the heavy oil and catalyst in the primary reaction tank 6 at a temperature of 270°C for 2 hours under a stirring speed of 40 rounds/min, with the pressure within the primary
5 reaction tank 6 set at 1.5 KPa. During the process of the visbreaking, the generated medium-temperature oil and gas 7-1 escaped from the primary reaction tank 6 and entered an oil and gas pipeline 2-1 in the feedstock pool 2, wherein the medium-temperature oil and gas 7-1 was at a temperature of 270°C. The intermediate product 3-3 obtained after completion of the visbreaking was
10 transported through a high temperature pump 4-3 into No. 1 secondary reaction tank 21-1. The medium-temperature flue gas 19-1 was discharged from the primary reaction tank 6 and formed medium-temperature waste flue gas 19-3 which entered a heat exchanger 16 for heat exchange with cold air, to obtain hot air 17, which was transferred into the flue gas furnace 19 for aiding combustion, wherein the
15 medium-temperature waste flue gas 19-3 was at a temperature of 350°C. A normal-temperature waste flue gas 19-5 obtained after the heat exchange between the medium-temperature waste flue gas 19-3 and cold air was transferred into a denitration and desulphurization device 18 for recycling, wherein the normal-temperature waste flue gas 19-5 was at a temperature of 30°C.

20 The temperature of the flue gas furnace 19 was adjusted to produce a high-temperature flue gas 19-2 which entered a heating cavity of the No. 1 secondary reaction tank 21-1, wherein the high-temperature flue gas 19-2 was at a temperature of 1200°C. A stirring device in the No. 1 secondary reaction tank 21-1 was initiated to perform catalytic cracking of the intermediate product 3-3 at a
25 temperature of 470°C for 1.5 hours under a stirring speed of 30 rounds/min, with the pressure within the No. 1 secondary reaction tank 21-1 set at 1.5 KPa. During the process of the catalytic cracking, the generated high-temperature oil and gas 7-2 escaped from the No. 1 secondary reaction tank and flowed into the oil and gas pipeline 2-1 in the feedstock pool 2, wherein the high-temperature oil and gas 7-2
30 was at a temperature of 470°C. The high-temperature flue gas 19-2 flowed out of the heating cavity of the No. 1 secondary reaction tank 21-1 and then formed high-temperature waste flue gas 19-4 which was transported to the heating cavity of the primary reaction tank 6, to provide the thermal energy for the visbreaking as described above with the residual heat of the high-temperature waste flue gas 19-4,
35 wherein the high-temperature waste flue gas 19-4 was at a temperature of 800°C.

The medium-temperature oil and gas 7-1 and the high-temperature oil and gas 7-2 were mixed within the oil and gas pipeline 2-1 in the feedstock pool 2 to produce a mixed gas 7-3 of the high-temperature oil and gas and the medium-temperature oil and gas, which was cooled in a condenser 8 by initiating a condenser fan 9, wherein the cooling temperature was 40°C, and after the cooling of the mixed gas 7-3 of the high-temperature oil and gas and the medium-temperature oil and gas, a mixture 7-4 of light oil and dry gas was obtained. A high pressure fan 10 was initiated to separate the mixture 7-4 of the light oil and the dry gas in a separator 11, producing the light oil 12 and the dry gas 13, in which the light oil 12 was sent into an oil storage tank 14-2 and the dry gas 13 was sent into a dry gas holder 14-1. When the output of the dry gas 13 was constant, the dry gas in the dry gas holder 14-1 was sent into the flue gas furnace 19 to supply heat for combustion.

After all the high-temperature oil and gas 7-2 produced during the catalytic cracking process within the No. 1 secondary reaction tank 21-1 entered the oil and gas pipeline 2-1, a cooling fan 20 was initiated to supply air into the heating cavity of the No. 1 secondary reaction tank 21-1, thereby cooling the petroleum coke produced in the catalytic cracking process to a temperature of 350°C; and a mechanical decoking device was initiated to discharge the petroleum oil.

When the catalytic cracking was performed in the No. 1 secondary reaction tank 21-1, the intermediate product 3-3 obtained in the primary reaction tank 6 was transported into No. 2 secondary reaction tank 21-2 where the catalytic cracking was repeated as described above to prepare light oil.

According to the method as described in the above embodiment, , the yield of the method for preparing light oil provided in EXAMPLE 5 of the present invention was calculated, and the calculated result indicated that the yield of the method for preparing light oil provided in EXAMPLE 5 of the present invention was 83.6%, which was high.

EXAMPLE 6

Light oil was prepared in accordance with the procedure as shown in Figure 1, which was specifically as follows.

A device for heating a catalyst heat tracing tank 1 and feedstock pool 2 was initiated to pretreat catalyst 3-2 and heavy oil 3-1 to a temperature of 70°C, in which the catalyst 3-2 was the catalyst prepared in EXAMPLE 3. The catalyst 3-2 was transported through a catalyst pump 4-2 into a mixing device 5, and the heavy oil

3-1 was transported through a heavy oil pump 4-1 into the mixing device 5; in the mixing device 5 the catalyst 3-1 and the heavy oil 3-2 were mixed uniformly and transported into a primary reaction tank 6 for visbreaking, wherein the catalyst pump 4-2 and the heavy oil pump 4-1 both had a metering function to allow that the dosage of the heavy oil 3-1 was 97 kg and the dosage of the catalyst 3-2 was 3 kg.

A flue gas furnace 19 was initiated to produce medium-temperature flue gas 19-1 which entered a heating cavity of the primary reaction tank 6, wherein the medium-temperature flue gas 19-1 was at a temperature of 600°C. A stirring device within the primary reaction tank 6 was initiated to perform visbreaking of the heavy oil and catalyst in the primary reaction tank 6 at a temperature of 255°C for 3 hours under a stirring speed of 50 rounds/min, with the pressure within the primary reaction tank 6 set at 1 KPa. During the process of the visbreaking, the generated medium-temperature oil and gas 7-1 escaped from the primary reaction tank 6 and entered an oil and gas pipeline 2-1 in the feedstock pool 2, wherein the medium-temperature oil and gas 7-1 was at a temperature of 255°C. The intermediate product 3-3 obtained after completion of the visbreaking was transported through a high temperature pump 4-3 into No. 1 secondary reaction tank 21-1. The medium-temperature flue gas 19-1 was discharged from the primary reaction tank 6 and formed medium-temperature waste flue gas 19-3 which entered a heat exchanger 16 for heat exchange with cold air, to obtain hot air 17, which was transferred into the flue gas furnace 19 for aiding combustion, wherein the medium-temperature waste flue gas 19-3 was at a temperature of 300°C. A normal-temperature waste flue gas 19-5 obtained after the heat exchange between the medium-temperature waste flue gas 19-3 and cold air was transferred into a denitration and desulphurization device 18 for recycling, wherein the normal-temperature waste flue gas 19-5 was at a temperature of 25°C.

The temperature of the flue gas furnace 19 was adjusted to produce high-temperature flue gas 19-2 which entered a heating cavity of the No. 1 secondary reaction tank 21-1, wherein the high-temperature flue gas 19-2 was at a temperature of 1000°C. A stirring device in the No. 1 secondary reaction tank 21-1 was initiated to perform catalytic cracking of the intermediate product 3-3 at a temperature of 455°C for 3 hours under a stirring speed of 50 rounds/min, with the pressure within the No. 1 secondary reaction tank 21-1 set at -0.5 KPa. During the process of the catalytic cracking, the generated high-temperature oil and gas 7-2 escaped from the No. 1 secondary reaction tank and flowed into the oil and gas

pipeline 2-1 in the feedstock pool 2, wherein the high-temperature oil and gas 7-2 was at a temperature of 455°C. The high-temperature flue gas 19-2 flowed out of the heating cavity of the No. 1 secondary reaction tank 21-1 and then formed high-temperature waste flue gas 19-4 which was transported to the heating cavity of the primary reaction tank 6, to provide the thermal energy for the visbreaking as described above with the residual heat of the high-temperature waste flue gas 19-4, wherein the high-temperature waste flue gas 19-4 was at a temperature of 650°C.

The medium-temperature oil and gas 7-1 and the high-temperature oil and gas 7-2 were mixed within the oil and gas pipeline 2-1 in the feedstock pool 2 to produce a mixed gas 7-3 of the high-temperature oil and gas and the medium-temperature oil and gas, which was cooled in a condenser 8 by initiating a condenser fan 9, wherein the cooling temperature was 45°C, and after the cooling of the mixed gas 7-3 of the high-temperature oil and gas and the medium-temperature oil and gas, a mixture 7-4 of light oil and dry gas was obtained. A high pressure fan 10 was initiated to separate the mixture 7-4 of the light oil and the dry gas in a separator 11, producing the light oil 12 and the dry gas 13, in which the light oil 12 was sent into an oil storage tank 14-2 and the dry gas 13 was sent into a dry gas holder 14-1. When the output of the dry gas 13 was constant, the dry gas in the dry gas holder 14-1 was sent into the flue gas furnace 19 to supply heat for combustion.

After all the high-temperature oil and gas 7-2 produced during the catalytic cracking process within the No. 1 secondary reaction tank 21-1 entered the oil and gas pipeline 2-1, a cooling fan 20 was initiated to supply air into the heating cavity of the No. 1 secondary reaction tank 21-1, thereby cooling the petroleum coke produced in the catalytic cracking process to a temperature of 250°C; and a mechanical decoking device was initiated to discharge the petroleum oil.

When the catalytic cracking was performed in the No. 1 secondary reaction tank 21-1, the intermediate product 3-3 obtained in the primary reaction tank 6 was transported into No. 2 secondary reaction tank 21-2 where the catalytic cracking was repeated as described above to prepare light oil.

According to the method as described in the above embodiment, the yield of the method for preparing light oil provided in EXAMPLE 6 of the present invention was calculated, and the calculated result indicated that the yield of the method for preparing light oil provided in EXAMPLE 6 of the present invention was 80.7%, which was high.

As can be seen from the examples above, the present invention provides a method for preparing light oil, comprising the steps of: 1) subjecting heavy oil to visbreaking under stirring to obtain an intermediate product; and 2) subjecting the intermediate product to catalytic cracking under stirring in the presence of a catalyst to obtain light oil. In the present invention, the light oil is prepared by combining the visbreaking and catalytic cracking processes which are both performed under stirring, and the reaction materials are dispersed through the stirring, so that the evaporation area of droplets of the reaction materials is increased, and thus the surface curvature of the droplets is increased and the vapor pressure of the droplets is thereby increased, which will increase the gasification amount of the reaction materials during the visbreaking and catalytic cracking processes and reduce the output of petroleum coke, thereby improving the yield of the method for preparing light oil provided according to the present invention; therefore, the method for preparing light oil provided according to the present invention has a high yield. In addition, preparation of light oil using a process combining visbreaking and catalytic cracking in the present invention can reduce damage of heavy oil to apparatuses during the light oil preparation.

The embodiments described above are only illustrated to assist understanding of the method of the present invention and core idea thereof. It should be noted that, for those skilled in the art, several improvements and modifications can be made with respect to the present invention without departing from the principle of the present invention, and such improvements and modifications fall within the protection scope of the claims of the present invention as well. The above description to the embodiments disclosed enables those skilled in the art to make or use the present invention, and various modifications to these embodiments will be obvious for those skilled in the art. The genetic principle defined herein may be applied to other embodiments without departing from the spirit or scope of the present invention. Therefore, the present invention is not intended to be limited to these embodiments shown herein but is to be accorded the widest scope consistent with the principles and novel features disclosed herein.

CLAIMS

1. A method for preparing light oil, comprising the steps of:

1) subjecting heavy oil to visbreaking under stirring to obtain an intermediate product, wherein the visbreaking is performed at a temperature of 240°C to 270°C, the visbreaking is performed at a pressure of -0.5 KPa to 1.5 KPa, and the stirring is at a speed of 30 to 50 rounds/min; and

2) subjecting the intermediate product to catalytic cracking under stirring in the presence of a catalyst to obtain the light oil, wherein the stirring is at a speed of 30 to 50 rounds/min.

2. The method according to claim 1, characterized in that the mass ratio of the heavy oil in step 1) to the catalyst in step 2) is (24 to 48):1.

3. The method according to claim 1, characterized in that the visbreaking in step 1) is performed for a period of 1.5 to 3 hours.

4. The method according to claim 1, characterized in that the catalyst in step 2) is cobalt naphthenate catalyst comprising, in parts by weight:

20 to 30 parts of cobalt naphthenate;

30 to 40 parts of ethylene glycol monomethyl ether;

3 to 5 parts of acid activated clay;

10 to 20 parts of glycerol stearate; and

20 to 37 parts of chlorinated paraffin.

5. The method according to claim 1, characterized in that the catalytic cracking in step 2) is performed at a temperature of 440°C to 470°C.

6. The method according to claim 1, characterized in that the catalytic cracking in step 2) is performed at a pressure of -0.5 KPa to 1.5 KPa.

7. The method according to claim 1, characterized in that the catalytic cracking in step 2) is performed for a period of 1.5 to 3 hours.

8. The method according to claim 1, characterized in that after completion of the catalytic cracking in step 2), the method further comprises:

cooling the resulting catalytically cracked product at a temperature of 40°C to 50°C to obtain the light oil.

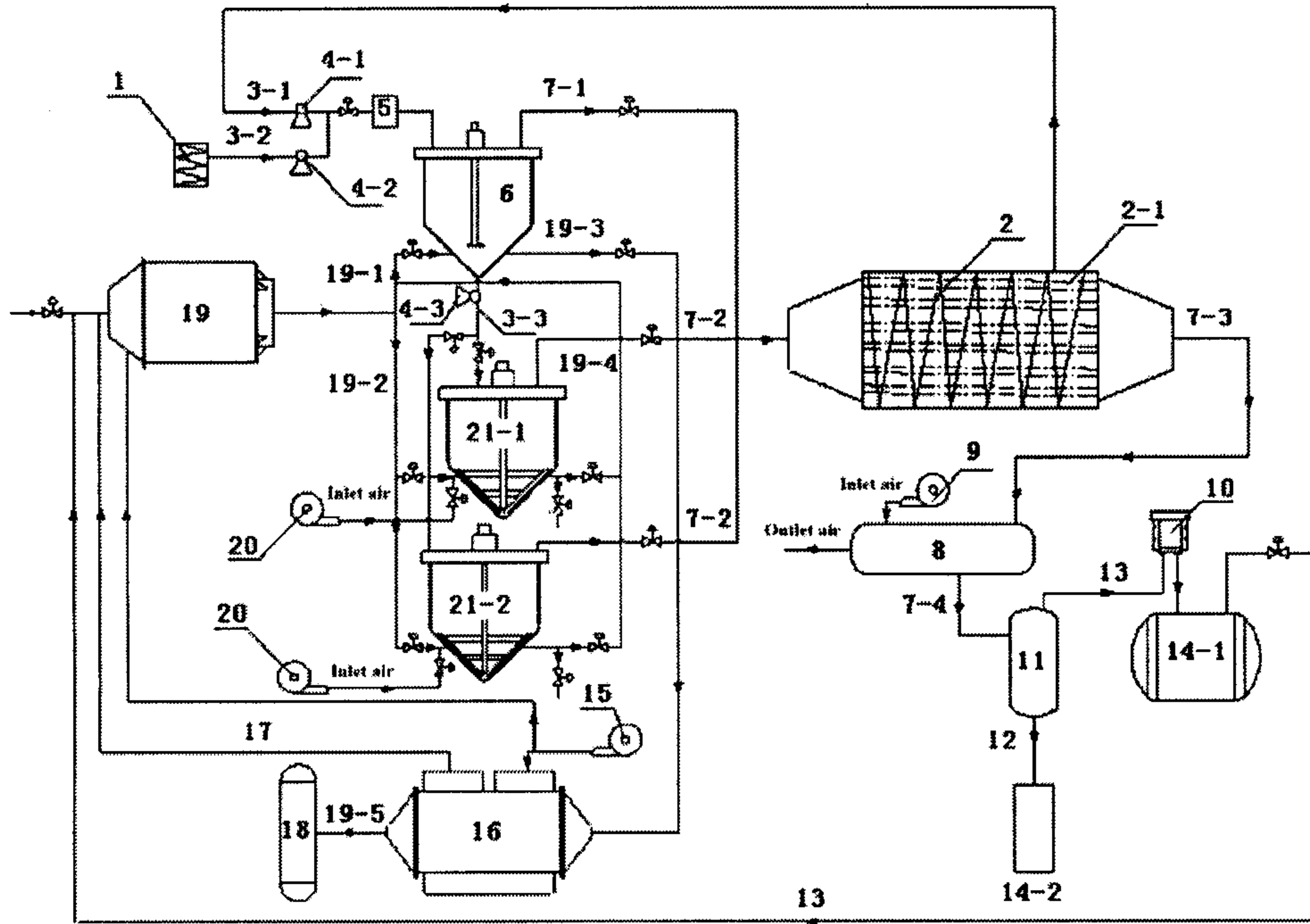

Figure 1

