

(19)



Europäisches Patentamt

European Patent Office

Office européen des brevets



(11)

EP 0 629 503 B1

(12)

EUROPEAN PATENT SPECIFICATION

(45) Date of publication and mention of the grant of the patent:
02.09.1998 Bulletin 1998/36

(51) Int. Cl.⁶: **B41J 2/045**, B41J 2/015

(21) Application number: **94109195.1**

(22) Date of filing: **15.06.1994**

(54) **Inkjet recording apparatus having electrostatic actuating means and method of controlling it**

Tintenstrahlauzeichnungsgerät mit elektrostatischem Betätiger und Verfahren zu seiner Steuerung

Appareil d'enregistrement par jet d'encre avec actionneur électrostatique et son procédé de commande

(84) Designated Contracting States:
DE FR GB IT

(30) Priority: **16.06.1993 JP 145212/93**

(43) Date of publication of application:
21.12.1994 Bulletin 1994/51

(73) Proprietor:
**SEIKO EPSON CORPORATION
Shinjuku-ku Tokyo 163-08 (JP)**

(72) Inventors:
• **Fujii, Masahiro,**
c/o Seiko Epson Corporation
Suwa-shi, Nagano-ken 391 (JP)
• **Miyashita, Ikuhiro,**
c/o Seiko Epson Corporation
Suwa-shi, Nagano-ken 391 (JP)

- **Koeda, Hiroshi,**
c/o Seiko Epson Corporation
Suwa-shi, Nagano-ken 391 (JP)
- **Kobayashi, Naoki,**
c/o Seiko Epson Corporation
Suwa-shi, Nagano-ken 391 (JP)
- **Oguchi, Asahiro,**
c/o Seiko Epson Corporation
Suwa-shi, Nagano-ken 391 (JP)

(74) Representative:
Hoffmann, Eckart, Dipl.-Ing.
Patentanwalt,
Bahnhofstrasse 103
82166 Gräfelfing (DE)

(56) References cited:
EP-A- 0 479 441 **JP-A- 2 289 351**
US-A- 4 275 402 **US-A- 4 282 535**
US-A- 4 398 204 **US-A- 4 520 375**

EP 0 629 503 B1

Note: Within nine months from the publication of the mention of the grant of the European patent, any person may give notice to the European Patent Office of opposition to the European patent granted. Notice of opposition shall be filed in a written reasoned statement. It shall not be deemed to have been filed until the opposition fee has been paid. (Art. 99(1) European Patent Convention).

Description

This invention concerns an inkjet recording apparatus, e.g. a printer, having electrostatic actuating means, and to a method of controlling it. In particular, the invention concerns a charge control means for the electrostatic actuator.

Inkjet printers using an electrostatic principle for pressure generation in an inkjet head are known in the prior art. JP-A-289351/1990 discloses an inkjet head comprising a silicon substrate having formed therein ink passages each connected to a respective inkjet nozzle at one end and to a common ink reservoir at the other end. A side wall portion of the ink passage is formed by a diaphragm as a vibration plate. A respective individual or nozzle electrode is provided on the outside surface of each diaphragm. Disposed opposite the nozzle electrodes, via a gap, is a common electrode. Each diaphragm with its nozzle electrode and the opposing common electrode constitute an electrostatic actuator with the nozzle electrode and the common electrode forming a pair of capacitor plates. A similar electrostatic actuator or fluid jet ejector is disclosed in US-A-4,520,375. In this latter prior art, by utilizing its semiconducting property, the thin silicon diaphragm itself forms one of the capacitor plates. Applying a time varying voltage to the capacitor causes the diaphragm to be set into mechanical motion and the fluid to exit responsive to the diaphragm motion. More particularly, when the actuator is charged to create an electrostatic field between the capacitor plates, the diaphragm will be displaced in a direction to increase the volume of the ink passage and correspondingly decrease the pressure, thereby taking in ink from the ink reservoir. A following discharge of the actuator causes the diaphragm to return to its initial position thereby decreasing the volume of the ink passage resulting in a corresponding increase of pressure in the ink passage. In response to the pressure increase ink is ejected through the nozzle.

The following is a more detailed description of the operation principle of such an electrostatic actuator comprising a pair of capacitor plates of which one is attached to or formed by a diaphragm and the other by a counter electrode (hereinafter referred to as a nozzle electrode or simply electrode) which is disposed opposite to the diaphragm. When a voltage is applied to the actuator, i.e. across the diaphragm and the nozzle electrode, the resulting electrostatic attraction force between the nozzle electrode and the diaphragm causes the diaphragm to bend towards the nozzle electrode. On the other hand, when bent, the diaphragm generates a restoring force. Therefore, the extent of the bending of the diaphragm during the application of a voltage to the actuator, i.e., the displacement of the mid-section of the diaphragm (hereinafter referred to as "equilibrium diaphragm displacement") is determined by the condition at which the electrostatic force and the diaphragm's restoring force are in equilibrium. If P_r

denotes the pressure acting on the diaphragm in response to the restoring force of the diaphragm, x the diaphragm displacement, A is a proportionality constant ($x \cdot A$ representing a change in volume) and K the compliance of the diaphragm (defined as change in volume per pressure), the relationship among these three variables is given by the following equation:

$$P_r = x \cdot A/K \quad (1)$$

Likewise, if V_a denotes the terminal voltage of the capacitor, l the distance (hereinafter "gap length") between the diaphragm and the nozzle electrode and ϵ the permittivity of the gap, then the pressure P_e acting on the diaphragm in response to the electrostatic force generated between the diaphragm and the nozzle electrode is given by equation (2) as:

$$P_e = \frac{\epsilon}{2} \cdot \frac{V_a^2}{(l-x)^2} \quad (2)$$

The equilibrium diaphragm displacement at which equilibrium ($P_r = P_e$) is established can be determined from Equations (1) and (2).

Figure 34 is a graphical representation of the relationships given by equations (1) and (2) namely the generated pressures P_r and P_e each as a function of the diaphragm displacement. These graphs are based on the following parameters: $K = 5 \times 10^{-18}$ [m⁵/N], $l = 0.25$ [μ m], $\epsilon = 8.85$ [pF/m].

The electrostatic pressure P_e as a function of x is shown for several values of the voltage V_a by respective curves in the figure. The relationship between the diaphragm displacement and the diaphragm restoring pressure is indicated by a straight line. Of two intersections between the straight line and each curve, the intersection on the left side indicates the equilibrium diaphragm displacement at the particular voltage level that is applied. At a voltage level at which the straight line representing the restoring pressure and the respective curve representing the electrostatic pressure do not intersect (e.g., 35 V), the electrostatic pressure is always greater than the restoring pressure of the diaphragm, irrespective of the displacement of the diaphragm. Therefore, in this case the displacement tends toward infinity. In practice, however, the maximum displacement of the diaphragm is restricted to the finite distance between the diaphragm and the nozzle electrode.

Applying such actuators as described above to an inkjet head of a recording apparatus involves the following problems.

Improving the operation speed of the recording apparatus requires an increase in the frequency at which the inkjet head is capable of continuously ejecting ink droplets, i.e., the response frequency of the inkjet head. When attempting to achieve a high response rate for the diaphragm, if the volume of the ink passage is

increased too rapidly by applying steep pulse voltages for charging the actuator, air bubbles intrude into the ink passage from the nozzle connected to it. Furthermore, rapid pressure variations of the ink in the ink passage may cause nitrogen and other gases dissolved in the ink, to bubble up. In the case such bubbles exist in the ink passage, any increase in pressure due to a sudden discharge of the actuator is absorbed by the bubbles, thus degrading or preventing ink ejection.

Further, a rapid attraction of the diaphragm to the nozzle electrode causes secondary vibrations of the diaphragm which in turn often cause a violent collision of the diaphragm against the nozzle electrode that may result in a damage of the inkjet head.

In addition to the above problem, electrostatic actuators tend to be driven improperly by external noise and induction noise because they can be driven by small electric charges. In particular, since actuators of on-demand type inkjet heads are often driven separately from their neighboring actuators, one or more actuators which are not to be driven at a given moment but are disposed side by side to an actuator that is to be driven, sometimes operate improperly due to the induction noise generated by the driving current for the driven actuator. Also in the actual operation of this kind of inkjet heads, the driving interval, namely the period between one ink ejection and the next ink ejection, often becomes fairly long. In such cases, the problem of malfunction caused by external noise arises.

In the prior art of US-A-4,520,375 referred to above the charge of the electrostatic actuator is controlled by a time varying voltage applied to it.

EP-A-0479 441 discloses an ink jet recording apparatus according to the pre-characterizing part of claim 1. This prior art mentions that providing a metal electrode opposite the electrode in the diaphragm increases the speed of injection/disappearance of charge.

An objective of the present invention is to provide an inkjet recording apparatus which allows high-quality recording in a stable manner at a high recording speed, and which has a high reliability and durability even when used for a long time. Another objective of the invention is to provide such recording apparatus which can be efficiently operated by a low drive voltage. Still another objective of the invention is to provide a method of driving such recording apparatus.

The objectives are achieved with a recording apparatus as claimed in claim 1 and a method as claimed in claim 15, respectively. Specific embodiments of the invention are subject-matter of the dependent claims.

The following is an explanation of the operation of the present invention. Figure 35 is a characteristic chart depicting the relationship between the displacement of the diaphragm and the electrostatic capacity of the actuator as determined by numerical calculations. In the figure, the horizontal axis shows the displacement of the diaphragm, and the vertical axis indicates the electrostatic capacitance. A displacement of the diaphragm

reduces the distance between the diaphragm and the nozzle electrode, thus increasing the electrostatic capacitance. In this case the capacitance changes in the range from approximately 200 pF to 1000 pF as a function of the displacement of the diaphragm.

In order to obtain for each ejected ink droplet the ink quantity necessary for high quality recording, the gap between the diaphragm and the nozzle electrode in the inkjet head of the present invention is preferably set at a minimum of 0.05 μ m and a maximum of 2.0 μ m, taking into consideration the practical drive voltage range applicable for ordinary recording apparatus. To minimize the drive voltage, the gap length should be as close to the lower limit as possible. However, the smaller the gap length the higher the liability of the diaphragm and the nozzle electrode coming into contact with each other, as noted above, with the risk of the head being destroyed.

The present invention provides a control of the charging process of the actuator whereby either the duration or the voltage of the drive pulses applied to the electrostatic actuator is set to a value or controlled such that the diaphragm does not touch the nozzle electrode even if the gap length between the diaphragm and the nozzle electrode is extremely small. Thus, there is no danger that the inkjet head might be damaged as a result of such contact. This ensures a long service life and a high reliability of the inkjet head. The controlled displacement of the diaphragm results in reduced variations in ink ejection and speed and, thus, improved recording quality. The small gap length permits the inkjet head to operate at a low drive voltage level. By appropriately controlling the charge rate and the discharge rate of the actuator a high response frequency can be obtained without danger of bubble generation.

Further objectives, advantages and specific embodiments of the present invention will be explained in detail below with reference to the drawings, in which:

- 40 Fig. 1 is a partially exploded perspective view of the inkjet head of a preferred embodiment of the invention,
- Fig. 2 is a side cross-section of the inkjet head shown in Fig. 1,
- 45 Fig. 3 is a sectional view from line A-A in Fig. 2,
- Fig. 4 is a schematic diagram illustrating the charge distribution in the electrostatic actuator,
- 50 Fig. 5 is a functional block diagram of an inkjet printer embodying the present invention,
- 55 Fig. 6 is a block diagram of a drive circuit used in a first embodiment of the present invention,

- Fig. 7 are circuit diagrams showing an example of charge and discharge circuits of the drive circuit of Fig. 6,
- Fig. 8 is a timing chart showing input signals to the drive circuit,, the voltage waveform of the actuator's terminal voltage, and a waveform representing the vibration of the ink meniscus formed at the tip of a nozzle,
- Fig. 9 are schematic diagrams illustrating the operation principle of the ink passage and actuator system,
- Fig. 10 is a circuit diagram showing an example of the timing pulse generation means,
- Fig. 11 is a timing chart for explaining a modification of the first embodiment wherein a hold period is provided between the charge and the discharge processes,
- Fig. 12 is a circuit diagram showing an example of the timing pulse generation means suitable for obtaining a hold period,
- Fig. 13 is a flow chart illustrating a microprocessor based implementation of the timing pulse generation means generating a hold period,
- Fig. 14 shows a simplified model for the determination of diaphragm displacement of the electrostatic actuator,
- Fig. 15 is a graph showing the relationship between the drive voltage applied to the electrostatic actuator and the diaphragm-nozzle electrode contact time,
- Fig. 16 is a timing chart for explaining a second and a third embodiment of the present invention,
- Fig. 17 is a block diagram of a drive circuit of the second embodiment of the present invention,
- Fig. 18 are circuit diagrams showing an example of a voltage detection circuit and a comparison circuit,
- Fig. 19 is a block diagram of a drive circuit of the third embodiment of the present invention,
- Fig. 20 are circuit diagrams showing an example of a current integration circuit and a comparison circuit,
- Fig. 21 is a block diagram of drive circuit of a fourth embodiment of the present invention,
- Fig. 22 are diagrams showing an example of a variable timing pulse generation means and a charge conditions storage means,
- Fig. 23 is a circuit diagram of an example of a printer condition detection means,
- Fig. 24 is a diagram showing the charge and discharge characteristics of the electrostatic actuator with the resistance value of a charge resistor as a parameter,
- Fig. 25 is a diagrammatic cross-section of the inkjet head,
- Fig. 26 is a timing chart for explaining a fifth embodiment of the present invention,
- Fig. 27 is a block diagram of a first example of the drive circuit of the fifth embodiment of the present invention,
- Fig. 28 is a circuit diagram showing an example of the target value generation means and the variable-voltage charge circuit,
- Fig. 29 is a flow chart illustrating a microprocessor based implementation of a target value generation means,
- Fig. 30 is a block diagram of a second example of the drive circuit of the fifth embodiment of the present invention,
- Fig. 31 is a circuit diagram showing an example of a variable-voltage charge circuit,
- Fig. 32 is a block diagram of the drive circuit of a sixth embodiment of the present invention,
- Fig. 33 schematically illustrates an inkjet printer embodying the present invention,
- Fig. 34 is a graphical representation of the electrostatic attraction force and the restoring force acting on the diaphragm versus the diaphragm displacement, and
- Fig. 35 is a characteristic curve showing the relationship between the diaphragm displacement and the electrostatic capacity of the actuator.

In the following embodiments the invention will be explained with respect to a printer as an example of an inkjet recording apparatus.

First Embodiment

Fig. 1 is a partially exploded perspective view and cross-section of a preferred embodiment of the inkjet head of a recording apparatus embodying the present invention. Note that while this embodiment is shown as an edge type head wherein ink is ejected from nozzles provided at the edge of a substrate, the invention may also be applied to a face type head wherein the ink is ejected from nozzles provided on the top surface of the substrate. Fig. 2 is a side cross-section of the assembled inkjet head, and Fig. 3 is a sectional view from line A-A in Fig. 2. The inkjet head 10 of this embodiment is made up of three substrates 1, 2, 3 one stacked upon the other and structured as described in detail below.

A first substrate 1 is sandwiched between second and third substrates 2 and 3, and is made from a silicon wafer. Plural nozzles 4 are formed between the first and the third substrate by means of corresponding nozzle grooves 11 provided in the top surface of the first substrate 1 such as to extend substantially in parallel at equal intervals from one edge of the substrate. The end of each nozzle groove opposite said one edge opens into a respective recess 12. Each recess in turn is connected via respective narrow grooves 13 to a recess 14. In the assembled state the recess 14 constitutes a common ink cavity 8 communicating via orifices 7 formed by the narrow grooves 13, and ink chambers 6 formed by the recesses 12 with the nozzles 4. In the present embodiment, each orifice 7 is formed by three parallel grooves 13 mainly to increase the flow resistance but also to keep the inkjet head operative if one of the grooves becomes clogged. Electrostatic actuators are formed between the first and the second substrate. The bottom of each ink chamber 6 comprises a diaphragm 5 formed integrally with the substrate 1. As will be understood, the grooves and recesses referred to above can be easily and precisely formed by photolithographic etching of the semiconductor substrate.

A common electrode 17 is provided on the first substrate 1. The magnitude of the work function of the semiconductor forming the first substrate 1 and the metal used for the common electrode 17 is an important factor determining the effect of electrode 17 on first substrate 1. The semiconductor material used in this embodiment has a resistivity of 8 - 12 Ω cm, and the common electrode 17 has in fact a two-layer structure made from platinum on a titanium base layer or gold on a chrome base layer. The base layer is provided mainly to improve the bonding strength between the substrate and the electrode. The present invention shall not be so limited, however, and various other material combinations may be used according to the characteristics of the semiconductor and electrode materials.

Borosilicate glass, such as Pyrex glass, is used for the second substrate 2 bonded to the bottom surface of first substrate 1. Nozzle electrodes 21 are formed on the surface of second substrate 2 by sputtering gold to a 0.1

μ m thickness in a pattern essentially matching the shape of diaphragms 5. Each of nozzle electrodes 21 comprises a lead member 22 and a terminal member 23. A 0.2 μ m thick insulation layer 24 for preventing dielectric breakdown and shorting during inkjet head drive is formed from a Pyrex sputter film on the entire surface of the second substrate 2 except for the terminal members 23. In addition or as an alternative to the insulation layer 24 an insulation layer (5a in Fig. 4) may be provided on the side of the diaphragms 5 facing the nozzle electrodes. Since the diaphragms 5 consist of a semiconductor material such insulation layer may be easily formed to a thickness of 0.1 μ m to 0.2 μ m by oxidizing the semiconductor material. Such oxide insulation layer exhibits excellent mechanical strength, insulation performance and chemical stability and substantially reduces the possibility of a dielectric breakdown in case of a contact between the diaphragm and the nozzle electrode. This is an advantage of using the semiconductor material itself as an electrode of the electrostatic actuator.

A recess 15 for accommodating a respective nozzle electrode 21 is provided below each diaphragm 5. Bonding the second substrate 2 to the first substrate 1 results in vibration chambers 9 being formed at the positions of recesses 15 between each diaphragm 5 and the corresponding nozzle electrode 21 opposite to it. In this embodiment, recesses 15 formed in the bottom surface of the first substrate 1 provide for gaps between the diaphragms and the respective electrodes 21. The length G (see Fig. 2; hereinafter the "gap length") of each gap is equal to the difference between the depth of recess 15 and the thickness of the electrode 21. It is to be noted that this recess can be alternatively formed in the top surface of the second substrate 2. In this preferred embodiment, the depth of recess 15 is 0.6 μ m, and the pitch and width of nozzle grooves 11 are 0.72 mm and 70 μ m, respectively.

As with second substrate 2, borosilicate glass is used for the third substrate 3 bonded to the top surface of first substrate 1. Bonding third substrate 3 to first substrate 1 completes formation of nozzles 4, ink chambers 6, orifices 7, and ink cavity 8. An ink supply port 31 is formed in third substrate 3 so as to lead into ink cavity 8. Ink supply port 31 is connected to an ink tank (not shown in the figure) using a connector pipe 32 and a tube 33.

First substrate 1 and second substrate 2 are anodically bonded at 300°C to 500 °C by applying a voltage of 500 V to 800 V, and first substrate 1 and third substrate 3 are bonded under the same conditions to assemble the inkjet head as shown in Fig. 2. After bonding the substrates, gap length G between diaphragms 5 and nozzle electrodes 21 is 0.5 μ m in this embodiment. The distance G1 between diaphragms 5 (or the insulation layer 5a, if any) and insulation layer 24 covering nozzle electrodes 21 is 0.3 μ m.

The thus assembled inkjet head is driven by means

of a drive unit connected by leads 101 to common electrode 17 and terminal members 23 of nozzle electrodes 21. The drive unit includes a plurality of drive circuits 40, one for each actuator. Ink 103 is supplied from the ink tank (not shown in the figures) through ink supply port 31 into first substrate 1 to fill ink cavity 8 and ink chambers 6.

Also shown in Fig. 2 is an ink droplet 104 ejected from nozzle 4 during inkjet head drive, and recording paper 105.

Fig. 4 is a schematic view illustrating the distribution of electric charges in the diaphragm and the nozzle electrode when the polarity of the applied voltage is selected in accordance with the present invention. A p-type silicon is used for first substrate 1 in this embodiment and the common electrode 17 and the nozzle electrodes 21 of the actuators are connected to drive circuits 40 (symbolized by a battery in Fig. 4) so that for charging an actuator a pulse voltage is applied by which the common electrode is rendered positive with respect to the nozzle electrode 21. The p-type silicon is doped with acceptor impurities such as boron and has as many holes as the number of acceptor atoms. The pulse voltage establishes an electrostatic field directed from the diaphragm to the nozzle electrode. Because of this field the holes 19 in the p-type silicon migrate towards insulation layer 5a leaving negatively charged acceptor ions. Because holes are injected from the common electrode 17 the negative charge of the acceptor ions is neutralized. Therefore, the diaphragm assumes a positive charge with no space-charge layer being created, i.e. the diaphragm or the first substrate functions as a conductor. In addition, a negative charge accumulates on the nozzle electrodes 21 side. As a result, the pulse voltage applied between a diaphragm 5 and its opposing nozzle electrode 21 generates an attractive force, due to static electricity, sufficient to deflect diaphragm 5 towards the nozzle electrode 21.

In order to obtain a distribution of charges as explained above, it is preferable to drive the electrostatic actuator by a unipolar drive voltage of a polarity selected depending on the conductivity type of the semiconductor material. It is to be understood, however, that the present invention is not restricted to unipolar drive voltages.

Fig. 33 shows an overview of a printer that incorporates the inkjet head 10 described above. 300 denotes a platen as a paper transport means that feeds recording paper 105. 301 indicates an ink tank that stores ink in it and supplies ink to the inkjet head 10 through an ink supply tube 306. The inkjet head 10 is mounted on a carriage 302 which is movable by means of a carriage drive unit 310, including a stepping motor, in a direction perpendicular to the direction in which the recording paper 105 is transported. In synchronization with the movement of the inkjet head, ink droplets are selectively ejected from a row of nozzles so as to print characters and/or graphics on the recording paper 105. Because it

is desirable to provide the drive unit as close to the inkjet head as possible, in this embodiment the drive unit is incorporated into the inkjet head 10. In the printer of Fig. 33 a device is provided for preventing the clogging of the inkjet head nozzles, a problem peculiar to printers that incorporate on-demand-type inkjet heads. To prevent the clogging of the nozzles, the inkjet head is moved to a position in front of a cap 304, and then ink discharge operations are performed several times while a pump 303 is used to suction the ink through the cap 304 and a waste ink recovery tube 308 into a waste ink reservoir 305.

Fig. 5 is a block diagram showing the configuration of one embodiment of a printer embodying the present invention. In the case of a terminal printer, a print request unit 61 is a host computer or another external device. In the case of a printer that is built into a system, it is a computing section within the system.

When receiving a print request from the print request unit 61, a printer controller 62 sends a drive signal to both a paper transport unit 300 and the carriage drive unit 310, thereby causing the carriage 302 on which the inkjet head 10 is mounted to be moved to a specified position on the recording paper and printing to be performed while the carriage 302 is being moved in the direction of printing. As mentioned before, a drive circuit 40 is connected to each of the actuators 27 of the inkjet head 10. Depending on the print data which it receives from the print request unit, the printer controller 62 sends a start-of-print signal S1 to the drive circuits 40 of one or more actuators 27 corresponding to the dot positions at which printing is to be performed. Upon receiving this signal, the drive circuits 40 drive the actuators 27. To reduce the wire inductance to the actuators, the drive circuits 40 should be mounted on the carriage in order to minimize the wire length. However, the present invention is not limited by the wire length. For the purposes of the present invention, the drive circuits can be placed outside the carriage.

Fig. 6 shows a block diagram of a drive circuit according to a first embodiment of the invention. The drive circuit consists of a timing pulse generation means 63, a charge circuit 64, and a discharge circuit 65. When a start-of-print signal S1 is input into the timing pulse generation means 63, the timing pulse generation means 63 sends a charge signal of a specified pulse width (charge period) to the charge circuit 64 in response to which the charge circuit 64 supplies a charge to the actuator 27. Subsequently, the timing pulse generation means 63 sends a discharge signal of a specified pulse width (discharge period) to the discharge circuit 65. The discharge circuit 65 then discharges the charge stored in the actuator 27. As mentioned before, this charging and subsequent discharging of the actuator 27 causes ink first to be suctioned and then ejected through the associated nozzle 4.

The following is a detailed explanation of the config-

uration and action of the electrostatic actuator and its drive circuit with reference to specific circuit examples.

Fig. 7 shows an example of a charge circuit 64 and a discharge circuit 65. Note that in Fig. 7 the actuator is represented by its equivalent capacitor (5, 21). Fig. 8 shows the charge and discharge signals 51 and 52 that are supplied to the charge and discharge circuits, respectively, the voltage waveform 53 of the actuator's terminal voltage V_a , and a waveform representing the vibration of the meniscus 102 of the ink 103 that is formed at the tip of the nozzle 4. Fig. 9 schematically illustrates the conditions of various stages in the vicinity of the ink chamber 6 when the actuator is driven.

Before time t_0 (Fig. 8), i.e., in the standby status, transistor 42 (Fig. 7) is off and transistor 45 is on. Consequently, the capacitor (5, 21) in Fig. 7 is in a discharged state. Therefore, the diaphragm 5 does not undergo a displacement. The ink chamber 6 remains in a condition that does not exert any pressure on the ink 103, as shown in Fig. 9(a).

When the charge signal 51 rises at time t_0 , the pnp transistor 42, driven via an inverting buffer 41, is turned on. At the same time the falling edge of discharge signal 52 renders npn transistor 45, via a non-inverting buffer 44, off. This causes a voltage to be applied to the capacitor (5, 21) via a charge resistor 43. As a result, a charge current flows in the direction of arrow A. The electrical charge stored in the capacitor (5, 21) causes an electrostatic force to act between the diaphragm 5 and the electrode 21. This, in turn, causes the diaphragm 5 to be attracted to the electrode 21, the volume of the ink chamber 6 to increase, as shown in Fig. 9(b), and the ink 103 in the vicinity of the ink chamber 6 to be attracted in the direction of the arrow. During this time, the voltage 53, i.e. the terminal voltage V_a of the capacitor (5, 21), changes, as shown by curve C in Fig. 8, according to the time constant which is determined by the resistor 43 and the capacitance of the capacitor (5, 21). As the diaphragm is displaced, the meniscus 102 varies as indicated by curve E in Fig. 8, i.e. it is drawn toward the ink chamber 6 (see Fig. 9(b)).

At time t_1 , the charge signal 51 is turned off, and, simultaneously, the discharge signal 52 is turned on. When this happens, the transistor 42 is turned off. This stops the charging of the capacitor (5, 21). On the other hand, because the transistor 45 is turned on, the electrical charge stored in the capacitor (5, 21) is discharged in the direction of arrow B through a discharge resistor 46. Because the discharge resistor 46 is set considerably smaller than the charge resistor 43 the time constant during the discharging process is smaller than that during the charging process, so that the discharge occurs in a short time, as shown by curve D in Fig. 8, compared to the length of time required in the charging process. When the discharge occurs, the diaphragm is suddenly released from the electrostatic attraction. Because of its elasticity, the diaphragm 5 returns to the standby position by its own, as shown in Fig. 9(c), thereby pressing

the ink in the ink chamber 6 suddenly. The pressure generated inside the ink chamber 6 causes an ink droplet 104 to be ejected from the nozzle 4. During this process the displacement 54 of the meniscus 102 changes, as indicated by curve F in Fig. 8. When the ejection pressure overcomes the viscosity and the surface tension of the ink 103 that tend to pull the ink back into the nozzle 4, the ink is ejected followed by attenuation vibrations of the ink system.

In Fig. 7, a discharge resistor 47 connected in parallel to the capacitor (5, 21) has a sufficiently higher resistance value than that of the charge resistor 43 and that of the discharge resistor 46. While exerting little influence during the charging or discharging process, when the head is operating, this discharge resistor 47 performs the function of gradually releasing the electrical charge that may be stored initially in the capacitor (5, 21) during the power-up stage. The discharge resistor 47 thus serves to keep the initial charge for the actuator at the zero level.

Fig. 10 shows an example circuit for the timing pulse generation means in this first embodiment. When the start-of-print signal S1 is input into the trigger input terminal of a monostable multivibrator 81, a positive pulse, whose time width is determined by an external resistor and capacitor, is output as charge signal at an output terminal Q. Because in this embodiment the discharging process is commenced at the same time as the charging of the actuator is stopped, pulses output from the \bar{Q} output terminal of multivibrator 81, namely the inverted charge signal can be used as the discharge signal.

In the embodiment explained above the charge that determines the maximum displacement of the diaphragm is controlled by the pulse width of the charge signal 51 and the charge time constant in such a way that the desired ink ejection is achieved on the one hand and a contact between the diaphragm and the nozzle electrode avoided on the other hand. The charge time constant is selected longer than the discharge time constant. This allows to select the speed of charging, i.e. the charge rate, as fast as possible but slow enough not to cause bubbles to be generated. On the other hand, the discharge rate is made faster than the charge rate enabling a fast overall response of the actuator. According to experiments, stable ink ejection was confirmed at a drive frequency of 3kHz under the following conditions: 30V drive voltage, 15 μ s charge period at 50 Ω charge resistance; and 45 μ s charge period at 5k Ω charge resistance. In both cases a 3.3 k Ω discharge resistor was used. The discharge period was about 300 μ s.

The resistance of the charge resistor 43 is closely related to the negative pressure generated in the ink chamber, i.e. the smaller the resistance, the larger the pressure. The negative pressure generated in the ink chamber is mainly determined by the differential pressure between the pressure exerted on the diaphragm in

response to the electrostatic force and that due to the restoring force, as well as the moving speed of the ink. Since the moving speed of the ink is limited by the flow resistance, the higher the charge rate the higher the dynamic negative pressure in the ink chamber. On the other hand, when the actuator is being charged, the generated electrostatic force is proportional to the square of the charge accumulated in the actuator and inversely proportional to the square of the distance between the diaphragm and the nozzle electrode. Therefore, in the beginning of the charging process, the attractive force increases slowly and so does the negative pressure in the ink chamber. As the diaphragm displacement approaches its target value the pressure increases more quickly. In other words, at the beginning of the charging process the influence of the charge rate on the pressure generated in the ink chamber is rather small. By contrast, the discharge starts at a small distance between the diaphragm and the nozzle electrode, so the discharge rate has a large effect on the pressure in the initial stage. Both, the charge circuit and the discharge circuit each inclusive of the actuator's capacitance have a first order delay response with a steep slope at the beginning which becomes more and more gentle as the process continues. Because of these mechanisms, depending on the individual case, determination of the resistance values of the charge and the discharge resistors should be done on the basis of the final charge rate and the initial discharge rate, i.e. rates effective when the diaphragm displacement is near its target value. For achieving a final charge rate smaller than the initial discharge rate it is not necessarily required to have the resistance of the charge resistor smaller than that of the discharge resistor.

A further improvement of the foregoing embodiment increasing the drive efficiency will be explained below.

At time t_1 , if only the charge signal 51 is turned off and the discharge signal 52 is maintained at the off status, (the ink system undergoes attenuation vibrations as indicated by the broken line in Fig. 8 representing the displacement 54 of the meniscus 102. The cycle T of these attenuation vibrations is determined by parameters such as the flow resistance of the ink passage. JP-A-2-24218 describes the fact that, in view of this phenomenon, by suctioning the ink for a time equal to $1/4$ of the attenuation vibration cycle T (until time t_2), or for a time slightly longer than $1/4 T$, and by pressurizing the ink at the end of the suction process, it is possible to utilize the vibration energy of the ink system during the ink ejection process in order to achieve a high degree of drive efficiency and an ink ejection that requires only small electric power.

However, normally the drive voltage will be high enough so that if only the charge period were long enough the actuator would be charged sufficiently for the diaphragm to come into contact with the nozzle electrode. Therefore the charging process is stopped

during the progress of diaphragm displacement before the diaphragm actually touches the nozzle electrode. Since the vibration phase of the ink system always lags behind the diaphragm vibration phase, when the discharging starts immediately after stopping the charging the vibration energy of the ink system cannot be utilized efficiently.

The means and a drive method effective for overcoming this problem will be explained with reference to Figs 11 to 13. Fig. 11 shows a timing chart illustrating the drive method. In the figure S1 denotes the start-of-print signal, and S2 an imaginary signal that depicts the states of the charge signal 51 and the discharge signal 52, wherein the high level indicates the charge signal, the low level the discharge signal, and the medium level a hold status. Except for a modification of the timing pulse generation means 63, the configuration of the drive circuit 40 is the same as that explained above with reference to Figs. 6 and 7.

When the start-of-print signal S1 is applied at time t_{10} , the timing pulse generation means 63 outputs a charge signal to the charge circuit 64. At time t_{11} , after a specified length of time necessary for an ink suction to occur, the timing pulse generation means 63 stops the charge signal, puts both the charge and the discharge circuit in an idle state, and holds the actuator 27 in the charged state. At time t_{13} , after a length of time corresponding to the phase delay of the ink system has elapsed, the timing pulse generation means 63 applies the discharge signal 52 to the discharge circuit 65, and thus begins to discharge the charge accumulated in the actuator.

This drive method, in which the charge state is held for a prescribed hold period after completion of the charging process and before the discharging process is commenced, ensures an effective utilization of the vibration energy of the ink system and, thus, an efficient ink ejection operation. The reason is that, after the displacement of the diaphragm is stopped, without the diaphragm ever touching the nozzle electrode, the actuator is kept in this state until the vibrations of the ink system reach a maximum. Then the actuator is discharged and the ink is pressurized.

Fig. 12 shows an example of a timing pulse generation means suitable for this embodiment. When the start-of-print signal S1 is input into the trigger input terminal of a first mono-stable multivibrator 82, a charge signal, whose time duration is determined by an external resistor and a capacitor, is output as a positive pulse. At the same time, the start-of-print signal S1 is similarly input into a second mono-stable multivibrator 83, and a discharge signal, whose time duration is determined by external elements, is output from the inverted output terminal \bar{Q} to the discharge circuit. In this circuit configuration the pulse width of the pulses generated by the first mono-stable multivibrator 82 is set shorter than the pulse width of the pulses generated by the second mono-stable multivibrator 83 by the length of

the hold period ($t_{13}-t_{11}$ in Fig. 11).

Fig. 13 is a flow chart illustrating another example of a timing pulse generation means for this embodiment, implemented through the use of a microprocessor. In this example a provision is made to allow the user to select the hold period setting either on or off. The following is a description of how the timing pulse generation means operates. When receiving the start-of-print signal S1, the microprocessor, not shown in the figure, sets the discharge signal in the inactive state at ST1, sets the charge signal in the active state at ST2, and begins charging the actuator 27. At ST3, the microprocessor sets the charge period (T_c) in a timer, at ST4 it detects the time-up condition of this timer, and at ST5 it stops charging while putting the charge signal in the inactive state. In doing so, at ST6 the microprocessor determines, based on printer specifications, whether or not the hold status is to be set. If the printer requires the hold status, the microprocessor sets a hold period (T_h) in the timer and maintains the hold status until the time-up condition of the timer is detected at ST8. After the time-up condition has been detected, or if the printer does not require the setting of the hold status, the microprocessor initiates the discharging process by setting the discharge signal 52 in the active state at ST9.

Note that as shown in the timing charts of Figs. 8 and 11, the discharge state is preferably maintained until the start of the succeeding charge (from t_{13} to t_{12} in Fig. 11). As a result, the inter-terminal impedance of the actuator is maintained fairly low, thus preventing the actuator from operating improperly under the influence of external noise or induction noise.

Second Embodiment

In the above embodiment, for allowing an accurate control of the charge in the actuator the power supply or drive voltage used for charging should be regulated not to fluctuate. However, where a sufficiently constant drive voltage cannot be ensured the charge conditions may be modified, as explained in this embodiment.

Fig. 14 shows a simplified model for determining the displacement of the diaphragm of the electrostatic actuator, where m denotes the sum of the ink inertance and the mass of the diaphragm, r is the ink's passage flow resistance, K is the diaphragm compliance (defined as change of volume per pressure), ϵ is the permittivity in the gap between the diaphragm and the nozzle electrode, V_a is the terminal voltage of the actuator, G is the length of the gap between the diaphragm and the nozzle electrode, A is a proportionality constant of unit m^2 and x is the displacement of the diaphragm. Based upon this model, the following motion equation, Equation (3), is obtained:

$$mAx'' + rAx' + Ax/K = (\epsilon/2) \cdot (V_a/(G - x))^2 \quad (3)$$

$$x(t=0) = x'(t=0) = 0$$

and

$$V_a = V_s \cdot (1 - e^{-t/RC}) \quad (4)$$

where V_s denotes the drive voltage used for charging, R is the resistance of the charge resistor 43 (Fig. 7), and C is the electrostatic capacity of the actuator.

As indicated in Equations (3) and (4), the displacement x of the diaphragm 5 is a function of the drive voltage V_s , and, consequently, the contact time, i.e. the period between the start of charging and the moment at which the diaphragm 5 gets into contact with the nozzle electrode, also varies with the drive voltage V_s . Fig. 15 shows an example of the relationship between drive voltage V_s and contact time. In this example the constants enumerated above have the following values:

$$\begin{aligned} m &= 1.0 \cdot 10^8 \text{ [kg/m}^4\text{]} \\ r &= 1.5 \cdot 10^{12} \text{ [N} \cdot \text{s/m}^5\text{]} \\ K &= 2.5 \cdot 10^{-18} \text{ [m}^5\text{/N]} \\ R &= 3.9 \text{ [k}\Omega\text{]} \\ C &\approx 650 \text{ pF (average over diaphragm displacement)} \end{aligned}$$

According to Fig. 15, in the neighborhood of a 30V drive voltage, normally the contact time varies at a rate of $2\mu\text{s}$ per volt. Therefore, to prevent any contact, the charge conditions such as the charge resistance value, i.e. the charge rate, or the charge period may be varied according to the power supply or drive voltage.

This second, like the following third and sixth embodiments are directed to means and drive methods for controlling the charging of the actuator dependent on the power supply voltage and/or other parameters. Other parameters include temperature, ambient pressure, humidity, ink viscosity etc. that may influence the actuator operation.

Fig. 17 is a block diagram of the drive circuit used in the second embodiment of the present invention. Fig. 16 is a timing chart that will be used to explain a drive method according to the present embodiment.

When the start-of-print signal S1 is applied from the printer controller 62 to the timing pulse generation means 63 at time t_{20} , the timing pulse generation means 63 supplies a charge signal 51 to the charge circuit 64 and begins charging the actuator 27. A comparison circuit 67 compares the terminal voltage of the actuator 27, detected by a voltage detection circuit 66, with a target voltage value corresponding to a specified charge amount q_0 . When the amount of charge built up in the actuator 27 reaches the specified value q_0 at time t_{21} , the comparison circuit 67 detects equality between the actual terminal voltage and the target voltage value and outputs a reset signal S4 to the timing pulse generation means 63. This causes the timing pulse generation means 63 to set the charge signal 51 in the inactive

state and stop the charging of the actuator. The operations that occur after this point are the same as those described in the first embodiment above.

Fig. 18 shows examples of the voltage detection circuit 66 and the comparison circuit 67 suitable for the second embodiment. The terminal voltage of the actuator 27, after undergoing a voltage division, is input into a comparator 85 through a voltage follower 84. In the comparator 85, the terminal voltage is compared with the target voltage value. If the comparison indicates that the detected voltage equals the target voltage value, the comparator 85 outputs a low-level reset signal to the timing pulse generation means. In the example circuit for the timing pulse generation means, shown in Figs. 10 and 12, the reset signal is input into the reset terminal of the mono-stable multi-vibrator, 81 or 82, thus causing the charge signal 51 to assume the inactive state. In the microprocessor implementation of the timing pulse generation means, shown as flow chart in Fig. 13, the presence or absence of a reset signal is tested at step ST4. If a reset signal is present, the charge process is immediately halted.

As noted above and shown in Fig. 34, the diaphragm displacement is a function of the terminal voltage, and thus the terminal voltage required to obtain a given diaphragm displacement can be predetermined. Further, the electric charge is in direct proportion to the terminal voltage with the capacitance as the proportionality factor being a function of the diaphragm displacement as shown in Fig. 35. Thus, the relationship between the terminal voltage and the electric charge can be determined uniquely by the amount of displacement of the diaphragm. Therefore, according to the above configuration, the charge pulses are regulated, not in terms of time, but in terms of the electrical charge or the terminal voltage which is a function of the charge. This permits an always accurate determination of the amount of displacement that the diaphragm 5 may undergo, which, in turn, can reduce the influence of variations in the resistance value of the charge resistor 43 or fluctuations in the value of the drive voltage. This results in an even more stable ink ejection.

Like in the first embodiment, the efficiency of ink ejection can be enhanced by providing a specified hold period before the discharge signal is put into the active state.

Further, as a means of measuring the amount of charge that is accumulated in the actuator, it is possible to use a means for detecting the integrated value of the charge current instead of the terminal voltage of the actuator. Fig. 19 shows a block diagram of this type of configuration. At time t_{20} (see Fig. 16), the timing pulse generation means 63 sets the charge signal 51 in the active state and simultaneously outputs a reset signal to a current integration circuit 68. Upon receiving this signal, the charge circuit 64 begins charging the actuator, and the current integration circuit 68 begins the integration of the charge current flowing to the actuator. The

integrated value of the charge current, i.e., the amount of charge, is compared in a comparison circuit 67 with a specified charge quantity q_0 , thus causing the generation of a reset signal when the compared values are equal. The operations that occur subsequent to this step are identical to those described in the above embodiment based on a voltage detection.

Fig. 20 shows a circuit example of the current integration circuit 68. A voltage proportional to the current, which is generated by a current detection resistor 87 provided in the charge path, is converted to a current value by an operation amplifier 86, and a constant-current driver 90 charges a capacitor 88. The capacitor 88 is discharged when a discharge transistor 89 is turned on by a reset signal transmitted from the timing pulse generation means 63. A voltage, proportional to the charge current that is integrated by the capacitor 88, is compared by the comparison circuit 67 with a specified value causing the generation of the reset signal when the two values are equal.

As explained above, the charging process of the actuator may be feedback controlled by comparing a parameter representative of the charge state of the actuator with a target value. In addition to the terminal voltage and the integrated charge current, other parameters like the displacement of the diaphragm or the pressure in the ink passage may alternatively be detected and used for this purpose.

Third Embodiment

In the second embodiment, either a voltage detection circuit or a current integration circuit 68 for directly detecting the charge state of the actuator 27, and a comparison circuit 67 are provided for each actuator thereby implementing a closed-loop or feedback control for the charging of the actuator. The provision of these elements increases the complexity of the circuitry. To prevent this problem, the present embodiment provides for an open-loop control by predetermining a respective optimal charge period for several values of the power supply or drive voltage, and setting the charge period based upon information obtained from a means for measuring this voltage.

Fig. 21 shows a block diagram of a drive circuit according to the third embodiment. When the start-of-print signal S1 is output from the printer controller 62, a variable timing pulse generation means 73 reads information on the condition of the printer from printer condition detection means 74, which detects printer conditions, such as the power supply voltage, and, based on this information, the variable timing pulse generation means 73 receives an optimal charge period for the current printer condition from charge condition memory means 75. As will be understood, memory means 75 has prestored therein for each of several power supply or drive voltage values the respective optimal charge period. Subsequently, the variable timing

pulse generation means 73 charges and discharges the actuator as described in the first embodiment. The charge condition memory means is capable of storing not only charge periods but also information on hold period. The following is a detailed explanation with reference to actual circuit examples.

Fig. 22 is a flowchart illustrating the sequence of operations that occur when the variable timing pulse generation means is implemented using a microprocessor. Fig. 23 is an example circuit that detects the drive voltage for the actuator as an example of a printer condition detection means. When receiving the start-of-print signal S1, the microprocessor stops the discharging process at ST31, and simultaneously begins the charging process at ST32. At ST33, the microprocessor receives information on printer conditions and status data from the printer condition detection means 74. In this example the "printer condition" refers to the voltage of a drive power supply unit (not shown). At ST34, the microprocessor starts up a subroutine for determining the length of charge period. At ST35, the subroutine assigns the status data to the pointer to a charge period table, and, at ST36, the subroutine references the table. At ST37, the subroutine reads charge period data from the table and passes the data to the main routine. Based on the charge period data, the main routine performs a series of processing tasks such as setting a timer. The operations that occur after this step are identical to those described in the first embodiment. If the hold period must be changed depending on a printer condition, all that needs to be done is to set up a hold period table and to perform the same processing tasks as in the case of setting the charge period. Thus it suffices to pass the status data to the pointer to the hold period table. In the circuit shown in Fig. 23, the voltage of the drive power supply is divided and converted to a digital value by an A/D converter 99. The points at which the drive power supply voltage is measured should, as much as possible, be on wires that are common to all charge circuits 64, several of which normally exist.

Fourth Embodiment

In the first to third embodiments described above the value of the charge resistance is a critical factor that influences the print quality of electrostatic actuator driven inkjet heads. The following explains the reason for this fact and describes a method of setting a charge resistance value.

Fig. 24 is a graph showing for three different charge resistance values the charge characteristic curve, i.e. the change in the amount of electrical charge accumulated in the actuator during the charging process. In the charge circuit 64 shown in Fig. 7, if the value of charge resistor 43, which determines the time constant during the charging process, is small the amount of electrical charge changes as indicated by solid line 55. If the value of charge resistor 43 is large, the change in the

amount of electrical charge varies according to solid line 57.

If the amount of electrical charge increases too slowly, as shown by solid line 57, the electrical charge necessary for ink suction cannot be obtained at time t41. Consequently, the change in the volume of the ink chamber 6 is not sufficient to produce a large enough ink ejection. If ink ejection is forced under these conditions, a significant degradation in print quality or even no ink ejection at all will result. Thus, in this case, to obtain a sufficient amount of electrical charge, the charge pulse width must be extended to time t43. This, however, decreases the responsiveness of the head and results in a failure to obtain the desired printing speed. According to experimental and computational verifications, a sufficient amount of ink suction occurs if the amount of electrical charge stored is approximately 90% of the capacity of the capacitance C of the actuator. Therefore, the ratio between the time constant (RC) of the charge circuit, determined by the charge resistance R and the capacitance C, and the charge period (T0), as determined from Equation (5), gives Formula (6), and this determines the maximum charge resistance value.

$$q = q_0 (1 - e^{-T_0/RC}) \quad (5)$$

$$q \geq 0.9q_0$$

$$T_0/RC \geq 2.3 \quad (6)$$

$$RC \leq 0.43T_0$$

On the other hand, when the amount of electrical charge increases too rapidly, as shown by line 55, the ink in the ink passage is attracted suddenly to the vicinity of the diaphragm, as indicated in Fig. 25. This causes either the intrusion of bubbles 106 from the nozzle due to a pressure (negative pressure) that is lower than the atmospheric pressure, or the occurrence of nitrogen and other gases dissolved in the ink as air bubbles 106 due to rapid vibrations of the ink in the ink passage. As discussed previously, when the electrical charge stored in the actuator is discharged under these conditions so as to reset the volume of the ink passage to the standby status, the pressure that would normally eject an ink droplet will be absorbed by the bubbles 106, thus leading to a phenomenon of no or no sufficient ink ejection. To prevent this problem it is also necessary to establish a lower limit on the time constant for the charge circuit. According to experimental verifications, even when a non-bubbling ink is used by removing nitrogen and other gases normally contained in the ink by degassing, the application of negative pressure, greater than 2×10^5 Pa, generates bubbles in the ink passage, thus preventing any ejection of ink.

When an experiment was conducted under the conditions of 30V drive voltage applied to the head, a

charge period T_0 of $15\mu\text{s}$, and a resistance of 50Ω for the resistor 43, no bubbles occurred and a stable ink ejection was obtained in the inkjet head with the electrostatic actuator that was used in the experiment. A measurement of the capacitance C gave approximately 270 pF resulting in an approximate time constant of $0.0135\mu\text{s}$.

Therefore, the inkjet drive method of the fourth embodiment ensures a stable ink ejection by setting the value of the charge resistor 43 within the range between an upper and a lower limit. The upper limit is determined by the condition that the time constant of the charge circuit is less than $1/2$ of the charge pulse width and the lower limit is determined by the condition that the negative pressure exerted on the ink during the suctioning of the ink is less than $2 \times 10^5\text{ Pa}$. As will be understood, in each of the first to third embodiments the charge resistor 43 may preferably be set within this range.

Fifth Embodiment

Fig. 27 is a block diagram that shows the drive circuit for the actuator according to a fifth embodiment of the present invention. Fig. 26 is a timing chart for explaining drive method employed in the fifth embodiment.

The following is an explanation of the composition and operation of the fifth embodiment with reference to Figs. 27 and 26.

A characteristic of this embodiment is that a variable voltage charge circuit 71 is used as a charge circuit to charge the actuator 27 and that a target value generation means 70 is provided that outputs a target charge voltage value to the variable voltage charge circuit the target value varying in accordance with the length of time that has elapsed since the charging process began. Upon receiving the start-of-print signal S_1 from the printer controller 62 at time t_{50} , the timing pulse generation means 63 inside the drive circuit outputs a charge signal S_2 to the target value generation means 70. As mentioned above, the target value generation means generates a target voltage varying with the length of time that has elapsed since it received the charge signal and supplies the generated target voltage to the charge circuit 71. Upon receiving this voltage, the charge circuit 71 supplies a charge voltage, equal to the target value, to the actuator.

When the charge signal S_2 from the timing pulse generation means 63 becomes inactive at time t_{51} , the target value generation means 70 stops generating target values, and the variable voltage charge circuit 71 stops charging the actuator. After that discharging of the actuator is performed as described in the preceding embodiments.

Fig. 28 shows example circuits of the target value generation means 70 and the variable voltage charge circuit 71 suitable for this embodiment. The charge signal from the timing pulse generation means 63 is

applied to the reset input of a counter 91. When the charge signal becomes active, the counter 91 begins operating, i.e., starts counting clock signals that are supplied by an oscillation circuit 94. The count value output from the counter 91 is a binary output and is input into the address input of a memory 92 in which target value data are stored. Therefore, the address in the memory is updated at every predetermined clock count, and the target value data stored at the respective address is supplied to the digital input of a D/A converter 93. Then, a target value is output from the D/A converter 93 as a voltage. When the charge signal becomes inactive, the counter 91 is reset. When this occurs, the target value data stored at address 00H of the memory 92 is input into the digital input of the D/A converter. Therefore, the charging of the actuator can be stopped by storing at this address a data value that forces the output of the charge circuit to assume a high impedance state. V_1 in Fig. 26 shows the resulting terminal voltage of the actuator. As shown in this example, the target values may be set such as to result in a hold period within the active portion of the charge signal.

The variable voltage charge circuit 71 is a constant-voltage driver having a negative feedback loop for feeding back part of its output voltage to its input. Thus, the variable voltage charge circuit is capable of producing output voltages that are proportional to the target voltages generated by the D/A converter 93.

Fig. 29 is a flow chart for explaining another example of the target value generation means 70 suitable for this embodiment, which uses a microprocessor. When, at time t_{50} , the start-of-print signal S_1 is output from the printer controller 62 and a charge signal is output by the timing pulse generation means 63, at ST_{21} the microprocessor initializes the address pointer to a table in which target value data are stored. At ST_{22} , the microprocessor updates the address, at ST_{23} , it reads the data stored at that address from the table, and outputs them to the D/A converter. Then, at ST_{24} , the microprocessor sets a timer to a specified time interval T_i at which the target value is to be updated. At ST_{25} , the microprocessor waits until the time-up condition occurs. After the time-up condition has been detected, at ST_{26} , the microprocessor checks whether or not the end of data in the target value table was reached. If there are still other data, the microprocessor loops to ST_{22} and outputs the next target value. If the end of data has been reached, at ST_{27} , the microprocessor outputs the data that set the charge voltage to 0V and thus terminates the generation of target values.

Fig. 30 shows a variation of the fifth embodiment employing a feedback control. In this case, instead of a target voltage value, a target charge value for the actuator is generated, the target charge value varying with the elapsed time since the beginning of the charging process, of the actuator. The actuator is charged by applying a charge current whose value is regulated based on the difference between the target charge

value and the integrated value of the charge current, which represents the actual charge accumulated in the actuator. In other words, this modification of the fifth embodiment employs a control that makes the actual charge in the actuator track the time varying target charge value.

As the target value generation means either a hardware solution using the above circuit examples or a software solution appropriately controlling a microprocessor may be employed. When the timing pulse generation means 63 applies a charge signal to the target value generation means, the target value generation means, as noted above, generates a time varying target charge value. On the other hand, the current integration circuit 68, described in the second embodiment, starts integrating the charge current upon receiving a charge signal from the timing pulse generation means 63. The integrated charge current value output from the current integration circuit is fed back as the instantaneous charge value to an adder (see Fig. 30) which provides the difference between the target charge value and the actual charge value of the actuator as a command charge current value to a variable current charge circuit 72. In this manner, the amount of charge stored in the actuator is always regulated so that it is equal to the target value from the target value generation means 70.

Fig. 31 shows a circuit example of the variable current charge circuit 72. A command current value, obtained by a differential amplifier 96 (forming the adder of Fig. 30) as the difference between the target charge value and the integrated current value, is level-shifted by a level converter 97 after having been attenuated, and is input into a constant-current driver 98. In this manner a charge current corresponding to the command current value is obtained.

In this manner, by providing a feedback control on the amount of charge stored in the actuator, this charge is regulated so that the diaphragm 5 does not touch the electrode 21, the amount of charge necessary to cause that level of suction that ensures adequate ink ejection is stored, an optimal gap is constantly maintained, and a stable ink ejection is achieved.

In the above fifth embodiment, memory 92 has prestored therein a table of target values. In this case, the target values rather than a charge period and a charge time constant determine the charge characteristic, i.e. the charge rate and the final charge amount of the actuator. With respect to the charge rate, the target values are preferably set based on the same considerations that have been explained in the fourth embodiment for the resistance value of the charge resistor 43, namely so that, during the ink suctioning process, the actuator is charged in a way that the negative pressure exerted on the ink is no greater than 2×10^5 Pa. As to the final charge amount, the target values are set to result in the amount of charge necessary to cause sufficient ink suction for ink ejection.

Sixth Embodiment

Although the above embodiments are based on the assumption that the electromechanical properties of the electrostatic actuator, the ink viscosity, and other properties are constant, in reality these properties may vary between production lots and may be subject to change due to aging or temperature. Therefore, charge period and target values are set in consideration of these factors to values that tend to deviate from optimal values to the safe side. As mentioned above, with the electrostatic actuator, the distance between the diaphragm and the nozzle electrode must be controlled so that the distance becomes as small as possible without the diaphragm and the nozzle electrode ever touching each other. However, setting safe values means that the closest distance between the diaphragm and the nozzle electrode is kept relatively large at the expense of drive efficiency and print quality. Further, even though a direct contact is prevented, the fact that the smallest distance can vary leads to uneven print quality, for example, the print density.

In view of these issues, as shown in Fig. 32, the sixth embodiment provides further improvement by incorporating a printer condition detection means 74, a variable-timing pulse generation means 73, and a charge condition storage means 75, in addition to the configuration used in the fifth embodiment; further, in the sixth embodiment the target value generation means is replaced with a variable target value generation means allowing to select among two or more tables of target values according to the condition of the printer. In this manner, a variation in the viscosity of the ink, for instance, can be easily compensated for, which would not be possible by simply changing the charge period.

As an example of a variable target value generation means using a microprocessor, reference is again made to Fig. 29. During the initialization of table addresses, at ST21, the variable target value generation means reads status data from the printer condition detection means and selects a corresponding target value table from plural prestored target value tables. After that, the target value generation means performs the same processing as that shown in the flowchart in Fig. 29. Specific examples of printer condition detection means include, in addition to those shown in Fig. 23, temperature detection means comprising a temperature detector, such as a thermistor, disposed in the vicinity of the inkjet head, an A/D converter for A/D converting the output voltage of the detector, and means for inputting the digital data to the microprocessor. Other detection means, like ambient temperature detection means, humidity detection means etc. may additionally or alternatively be provided and used to select optimum charge conditions from a plurality of prestored conditions.

The printer condition detection also includes the detection of printer setting conditions. In the case the inkjet heads and the drive circuits, which are the same

in specification, are used for printers of different specification, the inkjet head drive circuits can select the drive condition by detecting the printer specification, e.g., the power supply voltage, print density, recording media type and so on, from the setting status of, for example, a DIP switch mounted on the printer.

Although printer condition detection means have been described above as being applied to the fifth embodiment, it is to be noted that such detection means may also be employed in the other embodiments of the invention. For instance, it is feasible to replace the charge resistor 43 by controllable resistance means whose resistance value is controlled in response to detected printer conditions and/or settings.

Claims

1. An inkjet recording apparatus comprising
 - an inkjet head (10) having for each of one or more nozzles (4), an ink passage (6, 7, 8) in communication with the nozzle, and an actuator (27) comprising a pair of capacitor plates (5, 21) of which one plate is formed by or attached to a diaphragm (5) provided in a part of said ink passage, while the other plate is formed by an electrode (21) disposed outside of said ink passage in opposition to the diaphragm with a gap (G) therebetween, and means for charging and discharging the actuator (27) such as to displace the diaphragm (5) by an electrostatic force, thereby to eject ink droplets from said nozzle (4),
characterized in that said means for charging and discharging comprises charge control means (40, 62) including charge rate control means (43, 64; 70, 71) and discharge rate control means (46, 65, 99) for separately controlling the charge rate and the discharge rate.
2. The apparatus according to claim 1, wherein said charge rate control means (43, 64; 70, 71) is adapted to control the final charge rate to be smaller than the initial discharge rate.
3. The apparatus according to claim 1 or 2, wherein the charge rate control means is adapted to control the charge rate of the actuator (27) such that the negative pressure inside the ink passage does not exceed 2×10^5 Pa.
4. The apparatus according to any one of claims 1 to 3, wherein said charge control means (40, 62) comprises timing pulse generation means (63), charge means (64) responsive to a charge signal from said timing pulse generation means (63) for charging the actuator (27) and discharge means (65) responsive to a discharge signal from said timing pulse generation means (63) for discharging the actuator (27).
5. The apparatus according to claims 4, wherein said discharge means (65) comprises switch means (45) responsive to said discharge signal (52) for shorting said capacitor plates (5, 21) of the actuator through a discharge resistor (46) and/or said charge means (64) comprises switch means (41, 42) responsive to said charge signal (51) for applying a charge current through a charge resistor (43) to the actuator (27).
6. The apparatus according to claim 5, wherein the product of the resistance value of the charge resistor (43) and the capacitance of the actuator (27) is less than approximately half the active period of said charge signal (51).
7. The apparatus according to any one of the preceding claims, further comprising means (63) for providing a hold period between the end of a charge period and the start of a subsequent discharge period, said hold period selected in accordance with a phase lag between the diaphragm motion and a pressure vibration in said ink passage (6, 7, 8).
8. The apparatus according to any one of the preceding claims, wherein a discharge period extends from the end of the preceding charge period or the end of the preceding hold period, if any, to the start of the next charge period.
9. The apparatus according to any one of the preceding claims, wherein said charge control means (40, 62) further comprises means (66, 68) for detecting the value of a parameter representing the actual charge state of the actuator (27), comparison means (67) for comparing the detected value with a predetermined value and for outputting a control signal when the detected value is equal to the predetermined value, and means (63) for stopping the charging of the actuator in response to the control signal.
10. The apparatus according to any one of the preceding claims, further comprising recording condition detection means (74) for detecting recording conditions of the recording apparatus, said charge control means (40, 62) controlling the charge and/or charge rate depending on the detected recording conditions.
11. The apparatus according to any one of the preceding claims, wherein said charge control means (40, 62) includes:

- target value generation means (70, 73-76) for generating a target value corresponding to a desired amount of charge to be stored in the actuator (27), and
- target value charging means (63, 64, 66, 67) responsive to said target value for charging the actuator up to said desired amount of charge.
12. The apparatus according to claim 11, wherein said target value is varied with the length of time that has elapsed from the start of charging .
13. The apparatus according to claim 10 and one of claims 11 and 12, wherein said charge control means comprises storage means (75) having prestored therein charge/discharge conditions for the actuator (27) according to the recording conditions, the target value generation means (73-76) being adapted to generate a target value or a set of target values based on the charge/discharge condition retrieved from said storage means in response to the detected recording condition.
14. The apparatus according to any one of the preceding claims, wherein said actuator (27) is driven by a unipolar drive voltage.
15. A method of driving an electrostatic actuator in the inkjet head of an inkjet recording apparatus wherein the actuator is capable of moving a diaphragm associated with an ink passage in the inkjet head for increasing and decreasing the volume of the ink passage, comprising the steps of charging the actuator for increasing the volume and subsequent discharging the actuator for decreasing the volume, **characterized in that** the charging step includes controlling the charge rate at which the actuator is charged, the discharging step includes controlling the discharge rate at which the actuator is discharged, and the charge rate and the discharge rate are controlled separately from each other.
16. The method according to claim 15, comprising a step of holding the charge accumulated in the actuator for a predetermined hold period after the end of the charging step and before the start of the subsequent discharging step, said hold period selected in accordance with a phase lag between the motion of the diaphragm and a pressure vibration in said ink passage.
17. The method according to any one of claims 15 and 16 wherein said discharging step ends at or immediately before the start of the next charging step.
18. The method of any one of the claims 15 to 17, wherein said charging step comprises:

detecting a recording condition of said recording apparatus,
 generating, in response to the detected recording condition, a target value representing an amount of charge to be supplied to the actuator, and
 charging the actuator until its accumulated charge corresponds to the amount of charge represented by said target value.

Patentansprüche

1. Tintenstrahlauzeichnungsgerät, umfassend
- einen Tintenstrahlkopf (10), der für jede von einer oder mehreren Düsen (4) aufweist: einen in Verbindung mit der Düse stehenden Tintendurchlaß (6, 7, 8) und einen Aktuator (27), der ein Paar Kondensatorplatten (5, 21) aufweist, von denen eine Platte durch eine in einem Teil des Tintendurchlasses vorgesehene Membran (5) gebildet oder an jener befestigt ist, während die andere Platte aus einer Elektrode (21) gebildet ist, die außerhalb des Tintendurchlasses gegenüber der Membran mit einem Spalt (G) dazwischen angeordnet ist, und eine Anordnung zum Laden und Entladen des Aktuators (27) derart, daß die Membran (5) durch eine elektrostatische Kraft auslenkbar ist, um dadurch Tintentröpfchen aus der Düse (4) auszustoßen,
- dadurch gekennzeichnet**, daß die Anordnung zum Laden und Entladen eine Ladesteueranordnung (40, 62) enthält, welche eine Laderatensteueranordnung (43, 64; 70, 71) und eine Entladeratensteueranordnung (46, 65, 99) zum gesonderten Steuern der Laderate und der Entladerate aufweist.
2. Gerät nach Anspruch 1, bei dem die Laderatensteueranordnung (43, 64; 70, 71) ausgebildet ist, um die Entladerate so zu steuern, daß sie kleiner als die Anfangsentladerate ist.
3. Gerät nach Anspruch 1 oder 2, bei dem die Laderatensteueranordnung ausgebildet ist, um die Laderate des Aktuators (27) derart zu steuern, daß der Unterdruck im Tintendurchlaß $2 \cdot 10^5$ Pa nicht übersteigt.
4. Gerät nach einem der Ansprüche 1 bis 3, bei dem die Ladesteueranordnung (40, 62) eine Zeitsteuerimpuls-Erzeugungsanordnung (63), eine auf ein Ladesignal von der Zeitsteuerimpuls-Erzeugungsanordnung (63) ansprechende Ladeanordnung (64) zum Laden des Aktuators (27) sowie eine auf ein Entladesignal von der Zeitsteuerimpuls-Erzeugungsanordnung (63) ansprechende Entladean-

- ordnung (65) zum Entladen des Aktuators (27) aufweist.
5. Gerät nach Anspruch 4, bei dem die Entladeanordnung (65) eine auf das Entladesignal (52) ansprechende Schaltanordnung (45) zum Kurzschließen der Kondensatorplatten (5, 21) des Aktuators über einen Entladewiderstand (46) aufweist und/oder die Ladeanordnung (64) eine auf das Ladesignal (51) ansprechende Schaltanordnung (41, 42) zum Anlegen eines Ladestroms über einen Ladewiderstand (43) an den Aktuator (27) aufweist. 5
 6. Gerät nach Anspruch 5, bei dem das Produkt des Widerstandswerts des Ladewiderstands (43) und der Kapazität des Aktuators (27) kleiner als etwa die Hälfte der aktiven Periode des Ladesignals (51) ist. 15
 7. Gerät nach einem der vorhergehenden Ansprüche, ferner umfassend eine Anordnung (63) zur Schaffung einer Halteperiode zwischen dem Ende einer Ladeperiode und dem Beginn einer nachfolgenden Entladeperiode, wobei die Halteperiode nach Maßgabe einer Phasenverzögerung zwischen der Membranbewegung und einer Druckschwingung in dem Tintendurchlaß (6, 7, 8) gewählt ist. 20
 8. Gerät nach einem der vorhergehenden Ansprüche, bei dem sich eine Entladeperiode von dem Ende der vorhergehenden Ladeperiode oder dem Ende der gegebenenfalls vorhandenen vorhergehenden Halteperiode bis zum Beginn der nächsten Ladeperiode erstreckt. 25
 9. Gerät nach einem der vorhergehenden Ansprüche, bei dem die Ladesteueranordnung (40, 62) ferner aufweist: eine Anordnung (66, 68) zum Erfassen des Werts eines den tatsächlichen Ladezustand des Aktuators (27) repräsentierenden Parameters, eine Vergleichsanordnung (67) zum Vergleichen des erfaßten Werts mit einem vorbestimmten Wert und zum Ausgeben eines Steuersignals, wenn der erfaßte Wert gleich dem vorbestimmten Wert ist, und eine Anordnung (63) zum Beenden des Ladens des Aktuators als Antwort auf das Steuersignal. 30
 10. Gerät nach einem der vorhergehenden Ansprüche, ferner umfassend eine Aufzeichnungsbedingungs- erfassungsanordnung (74) zum Erfassen von Aufzeichnungsbedingungen des Aufzeichnungsgeräts, wobei die Ladesteueranordnung (40, 62) die Ladung und/oder Laderate abhängig von den erfaßten Aufzeichnungsbedingungen steuert. 35
 11. Gerät nach einem der vorhergehenden Ansprüche, bei dem die Ladesteueranordnung (40, 62) umfaßt:
 - eine Sollwerterzeugungsanordnung (70, 73-76) zum Erzeugen eines Sollwerts entsprechend einer im Aktuator (27) zu speichernden gewünschten Ladungsmenge, und
 - eine auf den Sollwert ansprechende Sollwertladeanordnung (63, 64, 66, 67) zum Laden des Aktuators bis zur gewünschten Ladungsmenge.
 12. Gerät nach Anspruch 11, bei dem der Sollwert mit der Zeitspanne variiert wird, die seit dem Beginn des Ladens verstrichen ist. 40
 13. Gerät nach Anspruch 10 und einem der Ansprüche 11 und 12, bei dem die Ladesteueranordnung eine Speicheranordnung (75) aufweist, in der Lade/Entladebedingungen für den Aktuator (27) nach Maßgabe der Aufzeichnungsbedingungen vorgespeichert sind, wobei die Sollwerterzeugungsanordnung (73-76) ausgebildet ist, um einen Sollwert oder einen Satz von Sollwerten auf der Basis der von der Speicheranordnung abhängig von der erfaßten Aufzeichnungsbedingung abgerufenen Lade/Entladebedingung zu erzeugen. 45
 14. Gerät nach einem der vorhergehenden Ansprüche, bei dem der Aktuator (27) durch eine unipolare Treiberspannung gesteuert ist. 50
 15. Verfahren zum Steuern eines elektrostatischen Aktuators im Tintenstrahlkopf eines Tintenstrahl- aufzeichnungsgeräts, bei dem der Aktuator in der Lage ist, eine einem Tintendurchlaß im Tinten- strahlkopf zugeordnete Membran zu bewegen, um das Volumen des Tintendurchlasses zu vergrößern und zu verkleinern, umfassend die Schritte des Ladens des Aktuators zum Vergrößern des Volumens und des nachfolgenden Entladens des Aktuators zum Verkleinern des Volumens, **dadurch gekennzeichnet**, daß der Ladeschritt das Steuern der Laderate umfaßt, mit der der Aktuator geladen wird, der Entladeschritt das Steuern der Entladerate umfaßt, mit der der Aktuator entladen wird, und die Laderate sowie die Entladerate getrennt voneinander gesteuert werden. 55
 16. Verfahren nach Anspruch 15, umfassend einen Schritt des Haltens der im Aktuator angesammelten Ladung für eine vorbestimmte Halteperiode nach dem Ende des Ladeschritts und vor dem Beginn des nachfolgenden Entladeschritts, wobei die Halteperiode nach Maßgabe einer Phasenverzögerung zwischen der Bewegung der Membran und einer Druckschwingung im Tintendurchlaß gewählt wird.
 17. Verfahren nach einem der Ansprüche 15 und 16, bei dem der Entladeschritt bei oder unmittelbar vor

Beginn des nächsten Ladeschritts endet.

18. Verfahren nach einem der Ansprüche 15 bis 17, bei dem der Ladeschritt umfaßt:

Erfassen einer Aufzeichnungsbedingung des Aufzeichnungsgeräts,
Erzeugen, als Antwort auf die erfaßte Aufzeichnungsbedingung, eines Sollwerts, der eine an den Aktuator zu liefernde Ladungsmenge repräsentiert, und
Laden des Aktuators, bis seine angesammelte Ladung der durch den Sollwert repräsentierten Ladungsmenge entspricht.

Revendications

1. Dispositif d'enregistrement à jet d'encre comportant

une tête (10) d'éjection d'encre ayant pour chacune d'une ou de plusieurs buses (4), un passage (6, 7, 8) d'encre en communication avec la buse, et un actionneur (27) comportant une paire de plaques (5, 21) de condensateur, l'une des plaques étant formée par une membrane (5) ou étant fixée à une membrane (5) disposée dans une partie du passage d'encre, tandis que l'autre plaque est formée d'une électrode (21) disposée à l'extérieur du passage d'encre en face de la membrane avec un intervalle (G) entre la membrane et l'électrode, et des moyens destinés à charger et à décharger l'actionneur (27) de manière à déplacer la membrane (5) par une force électrostatique, pour ainsi éjecter des gouttelettes d'encre de la buse (4),

caractérisé en ce que les moyens destinés à charger et décharger comportent des moyens (40, 62) de commande de charge comportent des moyens (43, 64; 70, 71) de commande de vitesse de charge et des moyens (46, 65, 99) de commande de vitesse de décharge destinés à commander de manière séparée la vitesse de charge et la vitesse de décharge.

2. Dispositif suivant la revendication 1, dans lequel les moyens (43, 64 ; 70, 71) de commande de vitesse de charge sont adaptés pour commander la vitesse de charge finale de manière à ce qu'elle soit plus petite que la vitesse de décharge initiale.

3. Dispositif suivant la revendication 1 ou 2, dans lequel les moyens de commande de vitesse de charge sont adaptés pour commander la vitesse de charge de l'actionneur (27) de sorte que la pression négative à l'intérieur du passage d'encre ne dépasse pas 2×10^5 Pa.

4. Dispositif suivant l'une quelconque des revendications 1 à 3, dans lequel les moyens (40, 62) de commande de charge comportent des moyens (63) de génération d'impulsions de temporisation, des moyens (64) de charge sensibles à un signal de charge provenant des moyens (63) de génération d'impulsions de temporisation destinés à charger l'actionneur (27) et des moyens (65) de décharge sensibles à un signal de charge provenant des moyens (63) de génération d'impulsions de temporisation destinés à décharger l'actionneur (27).

5. Dispositif suivant la revendication 4, dans lequel les moyens (65) de décharge comportent des moyens (45) de commutation qui sont sensibles au signal (52) de décharge pour court-circuiter les plaques (5, 21) de condensateur de l'actionneur par une résistance (46) de décharge et/ou les moyens (64) de charge comportent des moyens (41, 42) de commutation sensibles au signal (51) de charge et destinés à appliquer un courant de charge par une résistance (43) de charge à l'actionneur (27).

6. Dispositif suivant la revendication 5, dans lequel le produit de la valeur de résistance de la résistance (43) de charge et de la capacité de l'actionneur (27) est inférieur à approximativement la moitié de la période active du signal (51) de charge.

7. Dispositif suivant l'une quelconque des revendications précédentes, comportant en outre des moyens (63) destinés à fournir une période de maintien entre la fin d'une période de charge et le début d'une période de décharge suivante, la période de maintien étant sélectionnée conformément à un retard de phase entre le déplacement de membrane et une vibration de pression dans le passage (6, 7, 8) d'encre.

8. Dispositif suivant l'une quelconque des revendications précédentes, dans lequel une période de décharge s'étend de la fin de la période de charge précédente ou de la fin de la période de maintien précédente s'il en existe une jusqu'au début de la période de charge suivante.

9. Dispositif suivant l'une quelconque des revendications précédentes, dans lequel les moyens (40, 62) de commande de charge comportent en outre des moyens (66, 68) destinés à détecter la valeur d'un paramètre représentant l'état de charge réelle de l'actionneur (27), des moyens (67) de comparaison destinés à comparer la valeur détectée avec une valeur déterminée à l'avance et destinés à émettre en sortie un signal de commande lorsque la valeur détectée est égale à la valeur déterminée à l'avance et des moyens (63) destinés à arrêter la charge de l'actionneur en réponse au signal de

commande.

10. Dispositif suivant l'une quelconque des revendications précédentes, comportant en outre des moyens de détection (74) de l'état d'enregistrement destinés à détecter des états d'enregistrement du dispositif d'enregistrement, les moyens (40, 62) de commande de charge commandant la charge et/ou la vitesse de charge en fonction des états d'enregistrement détectés.

11. Dispositif suivant l'une quelconque des revendications précédentes, dans lequel les moyens (40, 62) de commande de charge comportent :

des moyens (70, 73 à 76) de production de valeurs cibles destinés à produire une valeur cible correspondant à une quantité souhaitée de charge que l'on souhaite emmagasiner dans l'actionneur (27), et

des moyens (63, 64, 66, 67) de charge de valeur de cible sensibles à la valeur cible et destinés à charger l'actionneur jusqu'à la quantité souhaitée de charge.

12. Dispositif suivant la revendication 11, dans lequel la valeur cible est modifiée avec le laps de temps qui s'est écoulé depuis le début de la charge.

13. Dispositif suivant la revendication 10 et l'une des revendications 11 et 12, dans lequel les moyens de commande de charge comportent des moyens (75) de mémorisation dans lesquels sont pré-mémorisés des états de charge/décharge pour l'actionneur (27) conformément aux états d'enregistrement, les moyens (73 à 76) de génération de valeurs cibles étant adaptés pour produire une valeur cible ou un ensemble de valeurs cibles sur la base de l'état de charge/décharge extrait des moyens de mémorisation en réponse à l'état d'enregistrement détecté.

14. Dispositif suivant l'une quelconque des revendications précédentes, dans lequel l'actionneur (27) est entraîné par une tension de commande monopolaire.

15. Procédé de commande d'un actionneur électrostatique dans la tête d'éjection d'encre d'un dispositif d'enregistrement à jet d'encre, dans lequel l'actionneur est capable de déplacer une membrane associée à un passage d'encre dans la tête d'éjection d'encre pour augmenter et diminuer le volume du passage d'encre, comportant les étapes qui consistent à charger l'actionneur destiné à augmenter le volume et à décharger ensuite l'actionneur pour diminuer le volume,

caractérisé en ce que l'étape de charge comporte le fait de commander la vitesse de charge

à laquelle l'actionneur est chargé, l'état de décharge comporte le fait de commander la vitesse de décharge à laquelle l'actionneur est déchargé et la vitesse de charge et la vitesse de décharge sont commandées séparément l'une de l'autre.

16. Procédé suivant la revendication 15, comportant une étape qui consiste à maintenir la charge accumulée dans l'actionneur pendant une période de maintien déterminée à l'avance après la fin de l'étape de chargement et avant le début de l'étape de chargement suivante, la période de maintien étant sélectionnée conformément à un retard de phase entre le déplacement de la membrane et une vibration de pression dans le passage d'encre.

17. Dispositif suivant l'une quelconque des revendications 15 et 16, dans lequel l'étape de décharge se termine au début ou immédiatement avant le début de l'étape de charge suivante.

18. Dispositif suivant l'une quelconque des revendications 15 à 17, dans lequel l'étape de charge comporte :

le fait de détecter un état d'enregistrement du dispositif d'enregistrement,

le fait de produire, en réponse à l'état d'enregistrement détecté, une valeur cible représentant une quantité de charge destinée à être envoyée à l'actionneur, et

le fait de charger l'actionneur jusqu'à ce que sa charge accumulée corresponde à la quantité de charge représentée par la valeur cible.

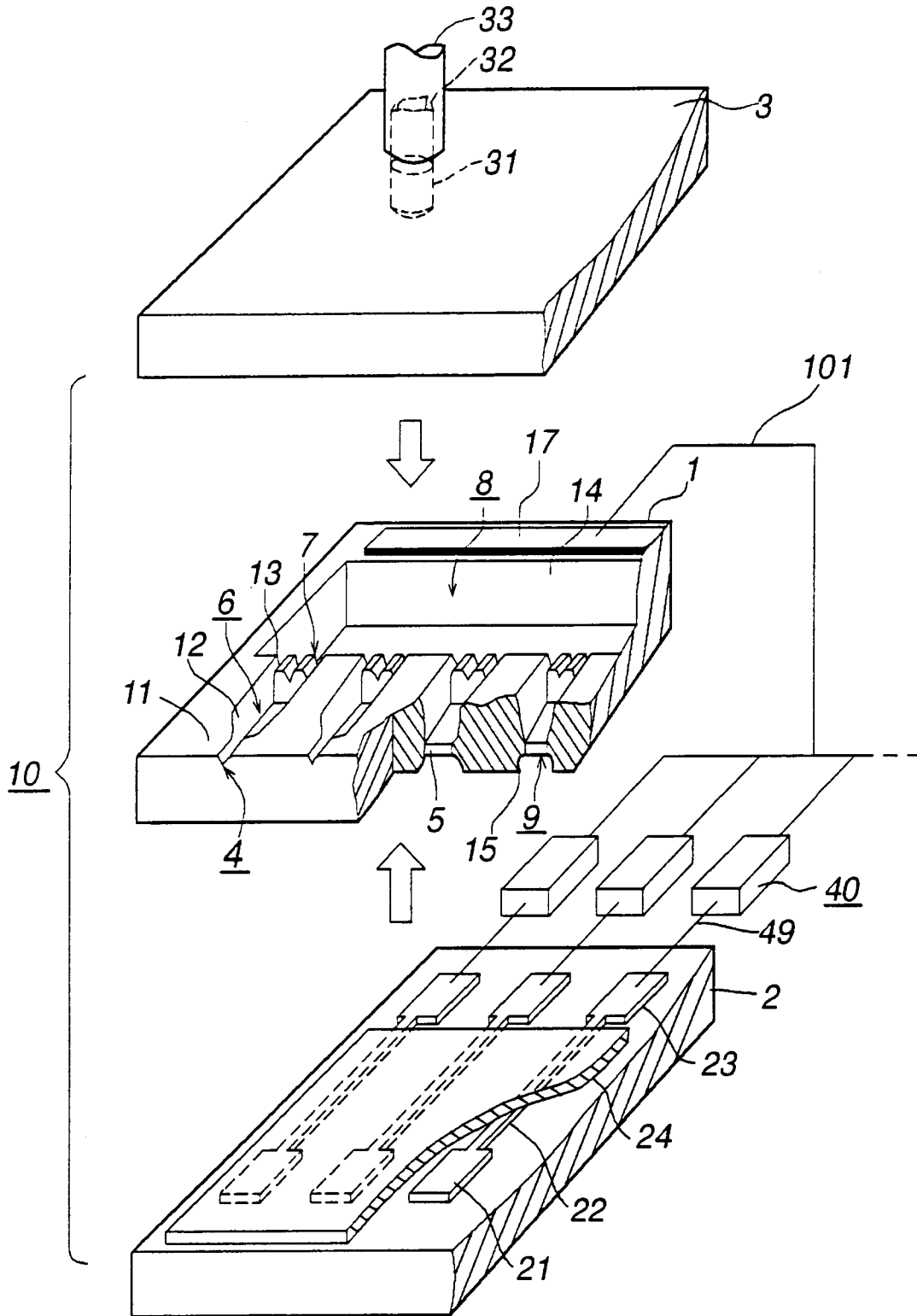

FIG. 1

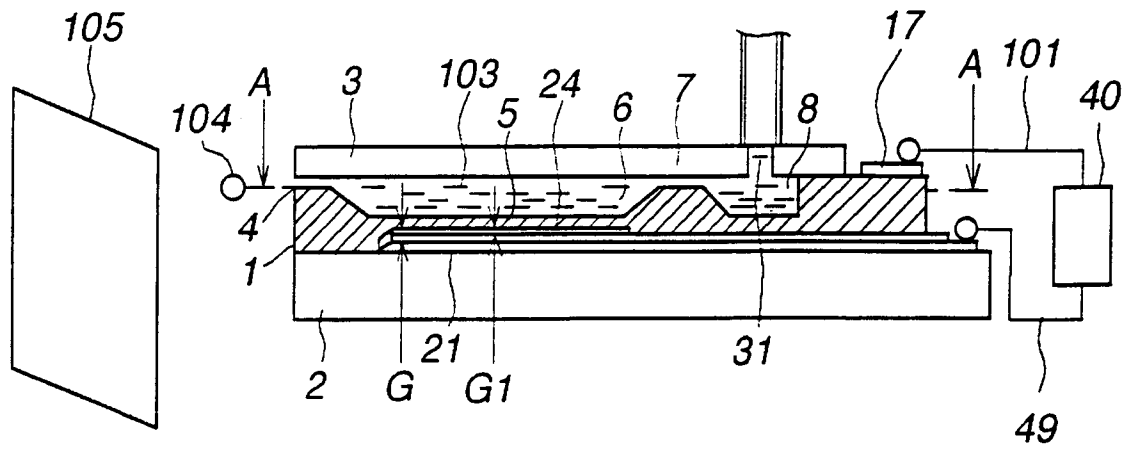

FIG. 2

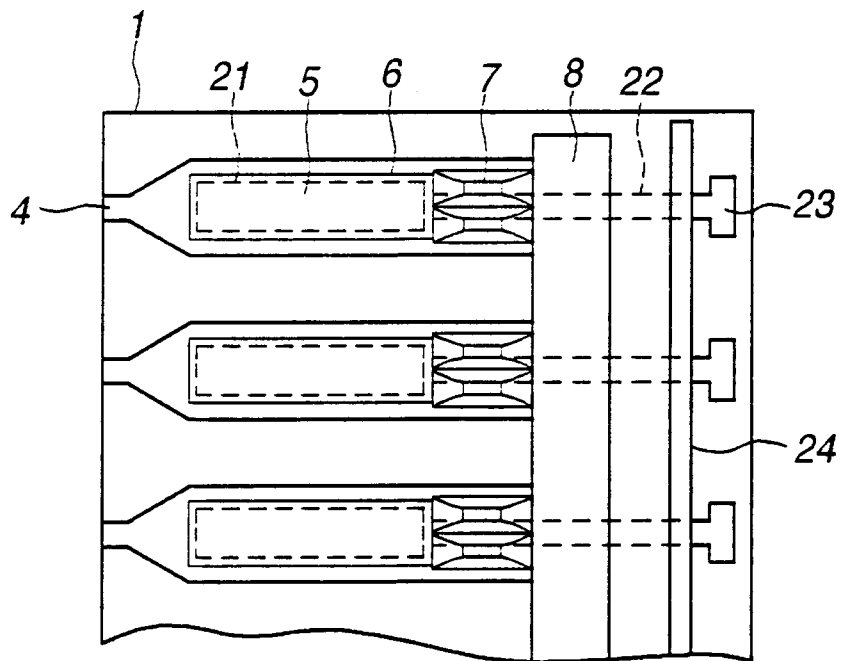

FIG. 3

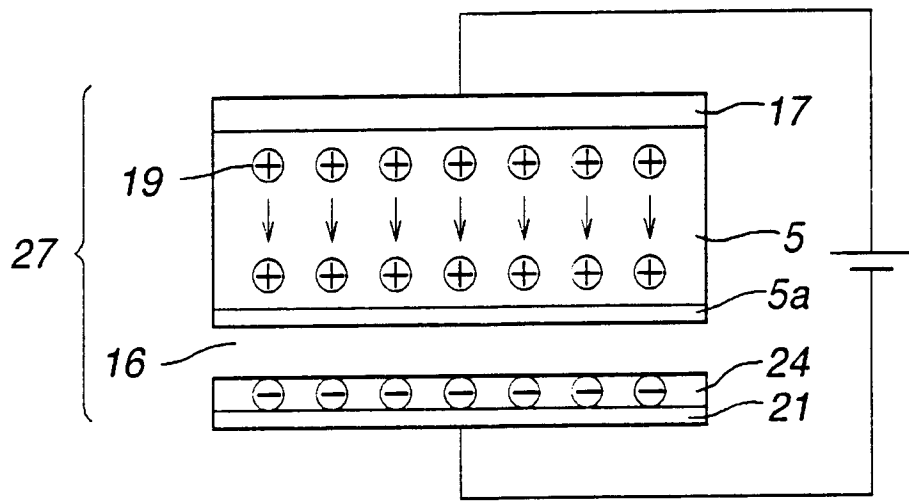

FIG. 4

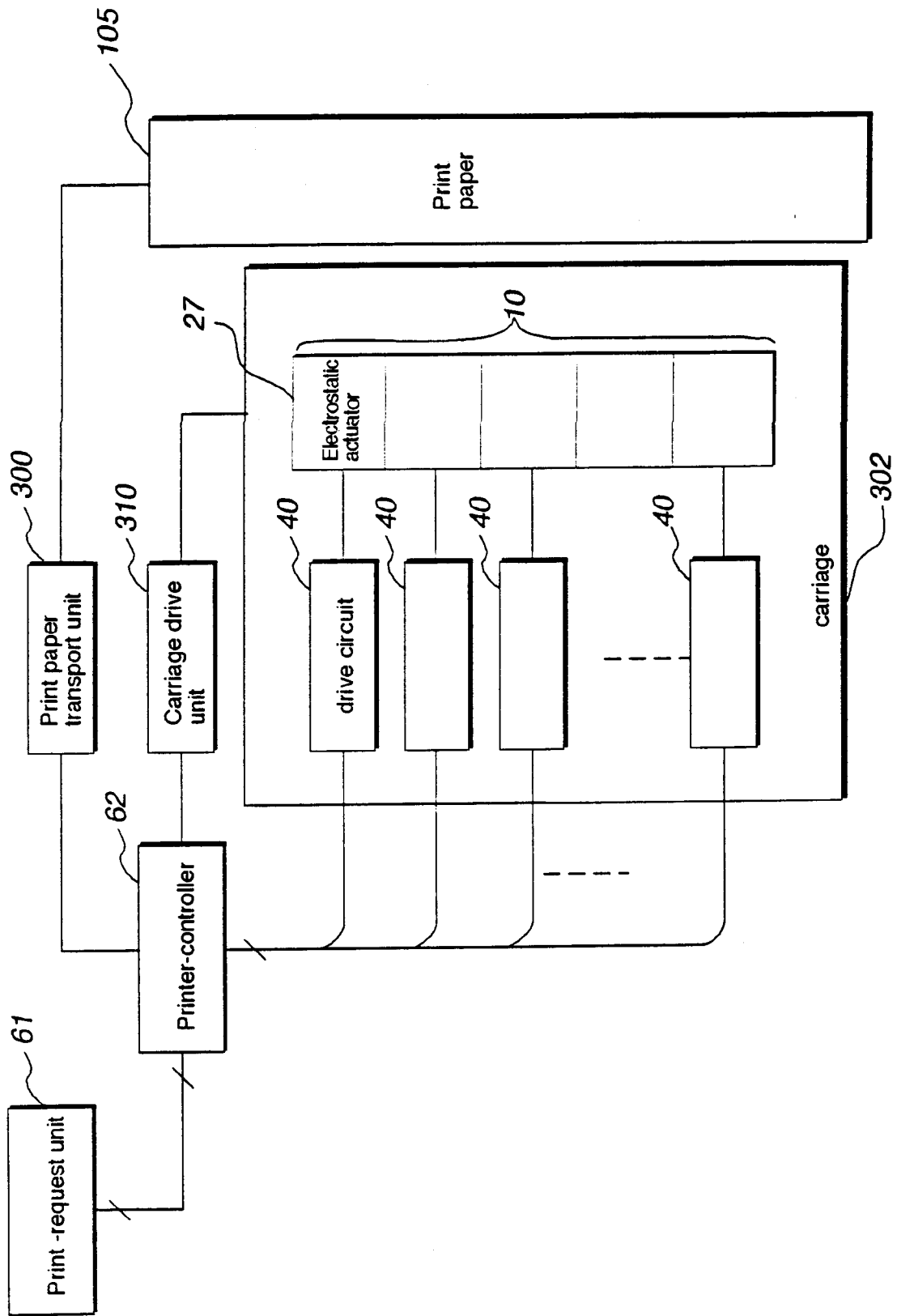

FIG. 5

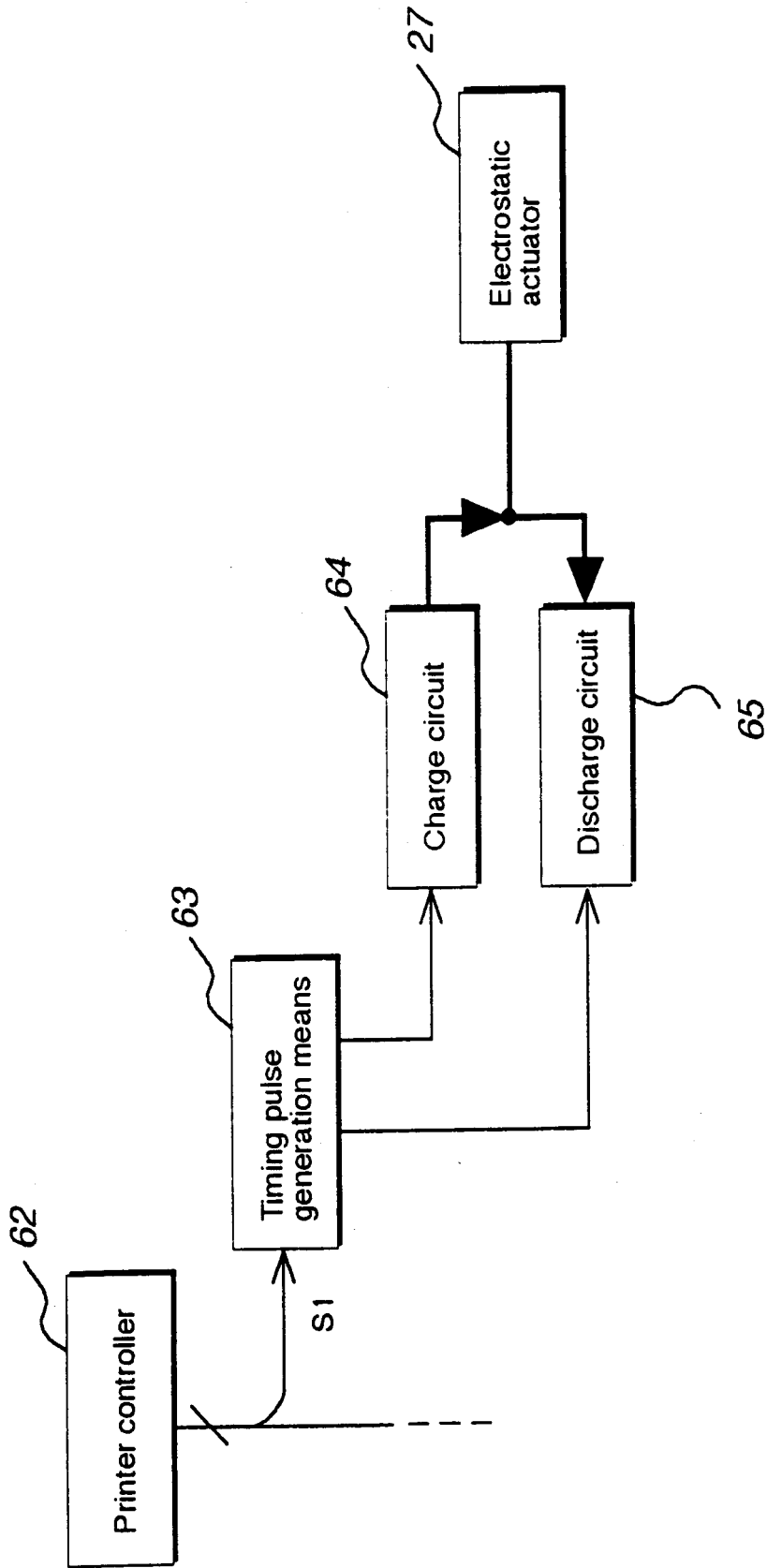

FIG. 6

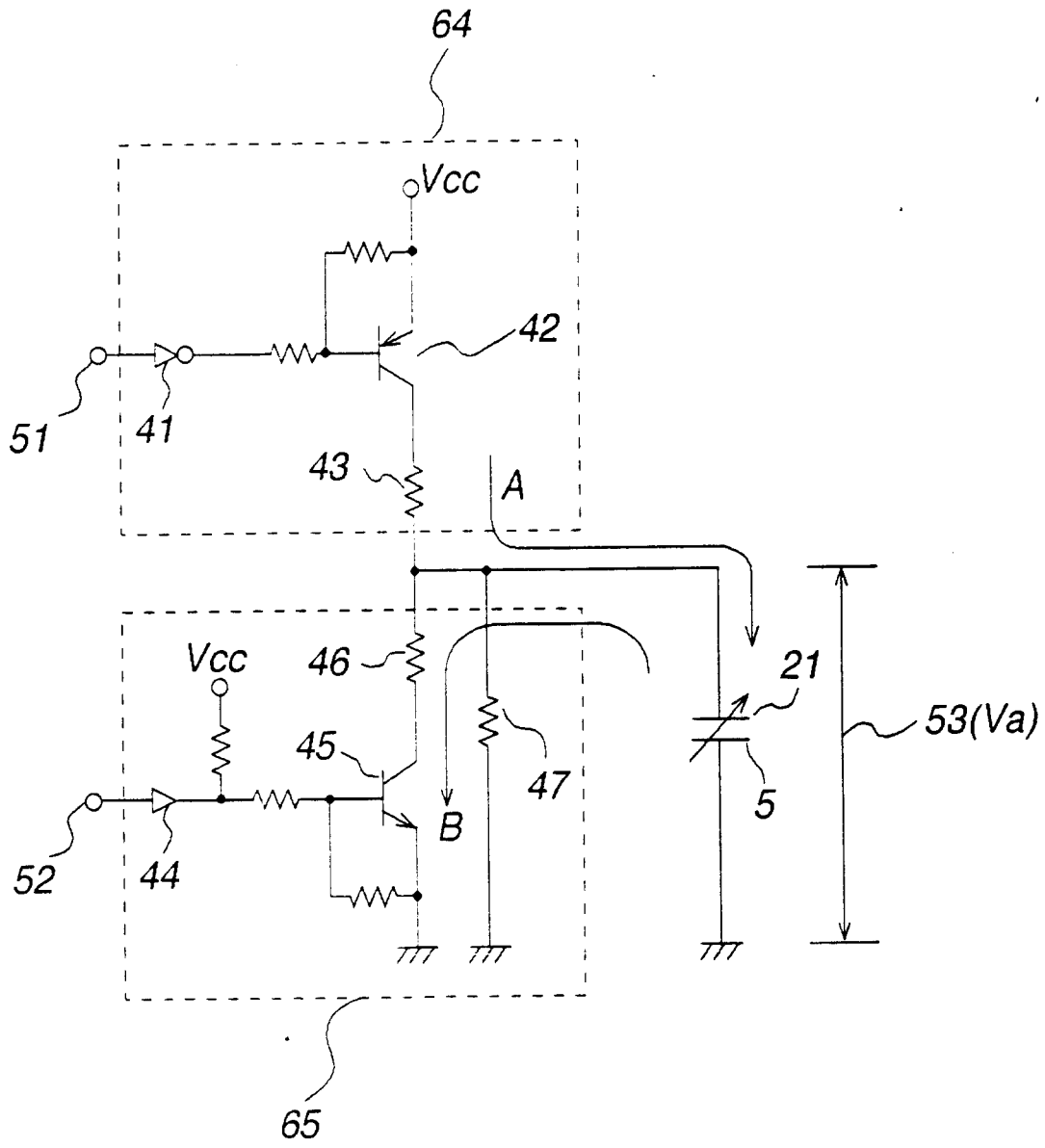

FIG. 7

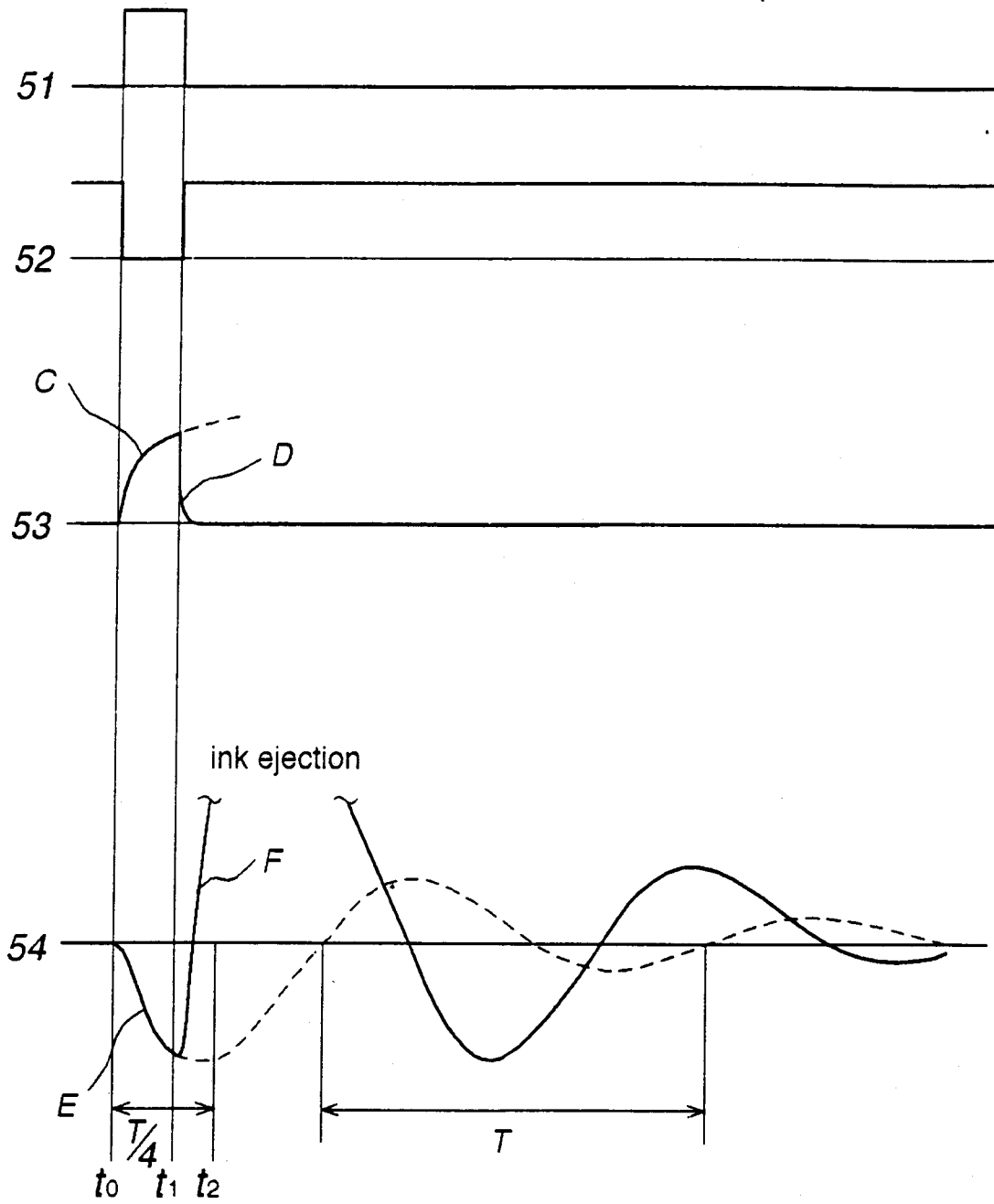

FIG. 8

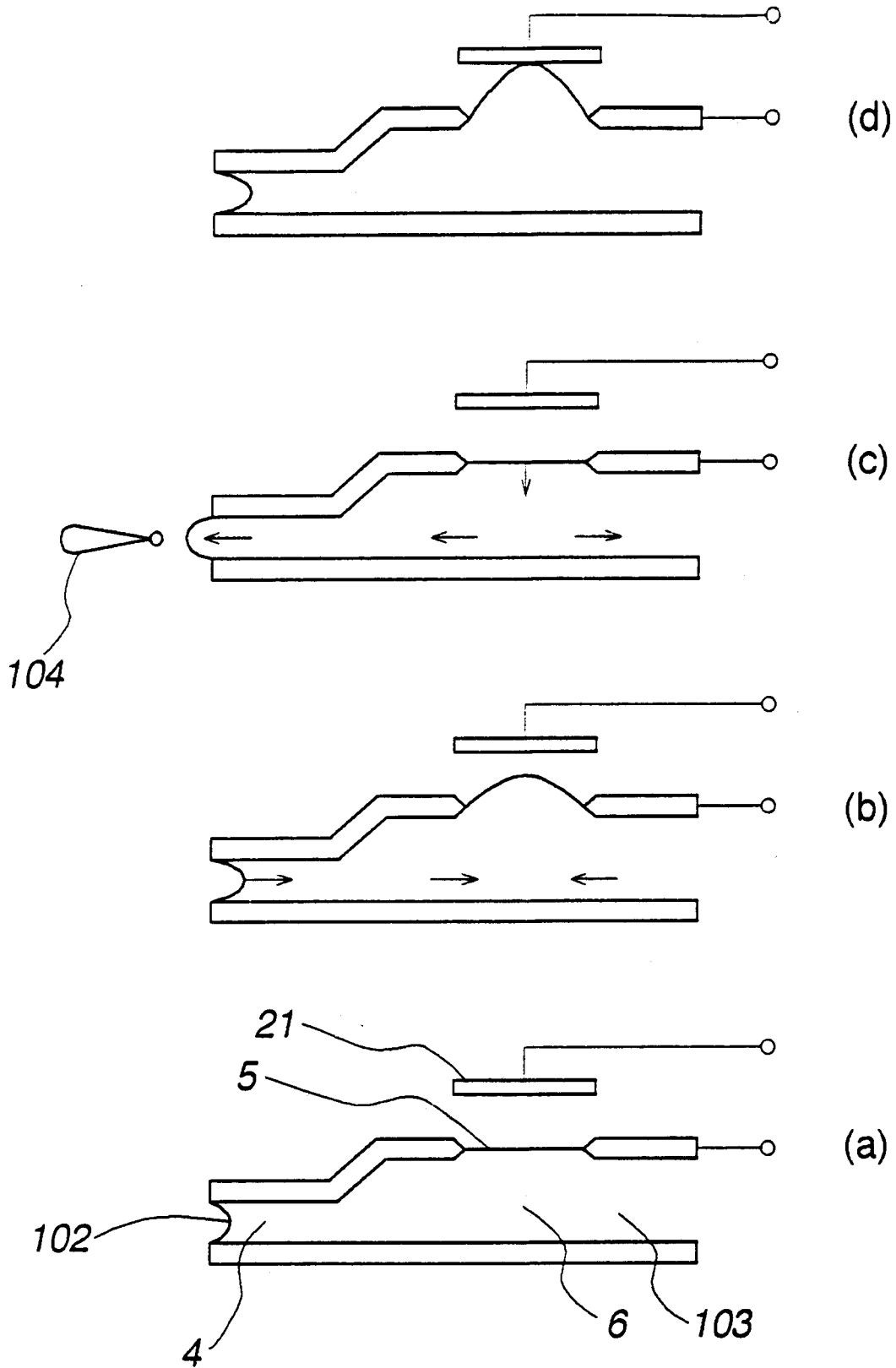

FIG. 9

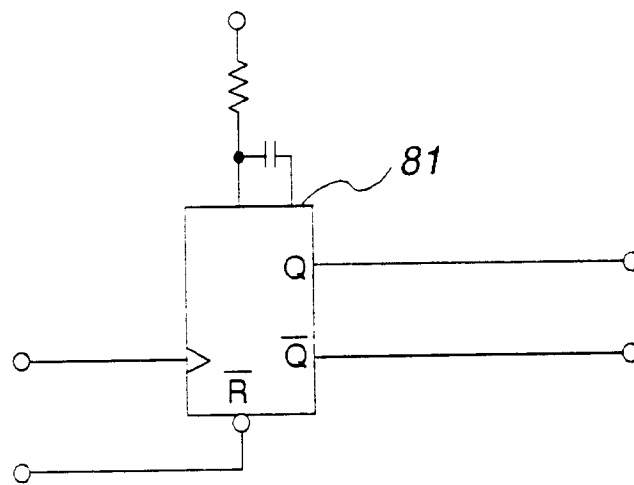

FIG. 10

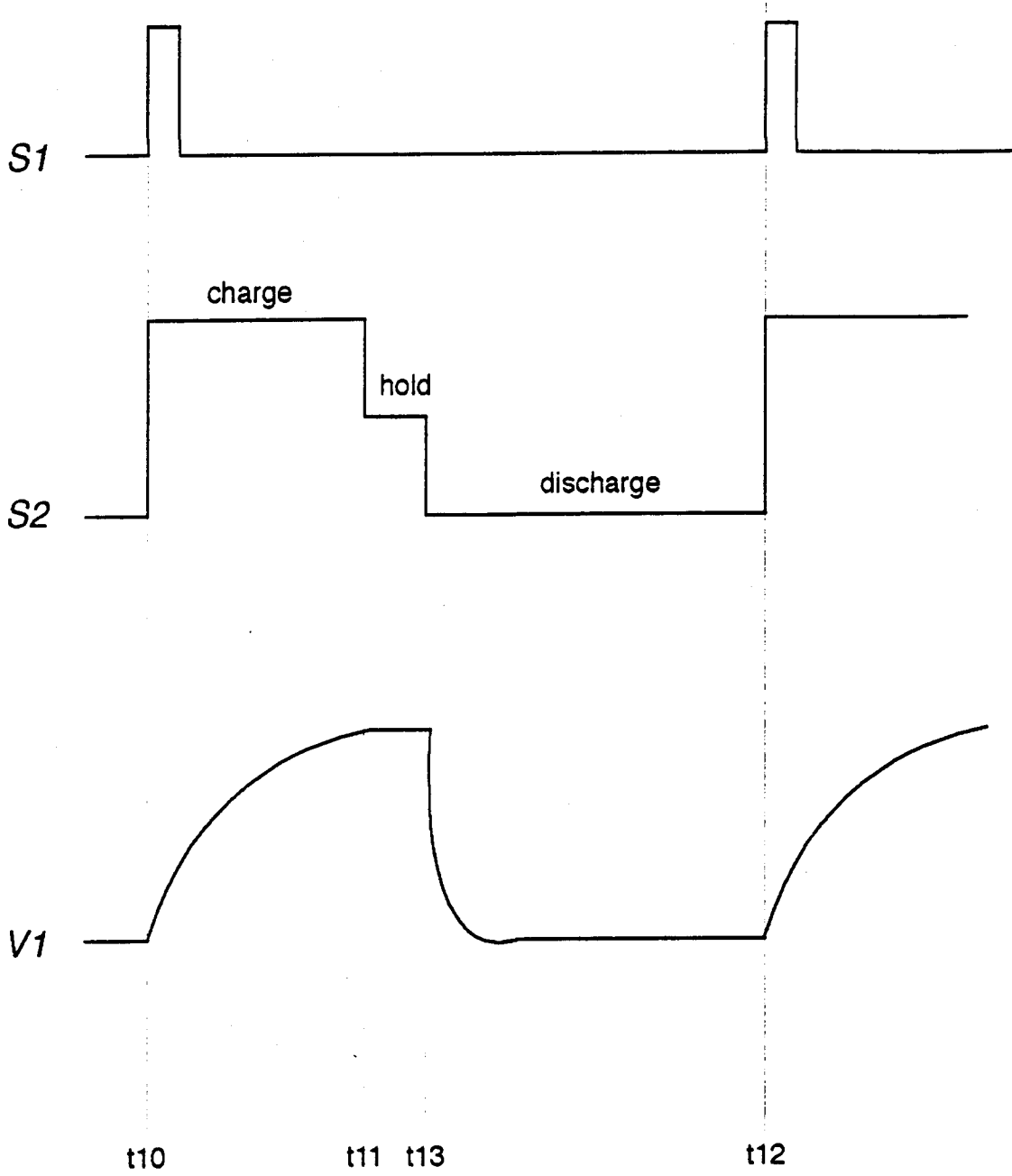

FIG.11

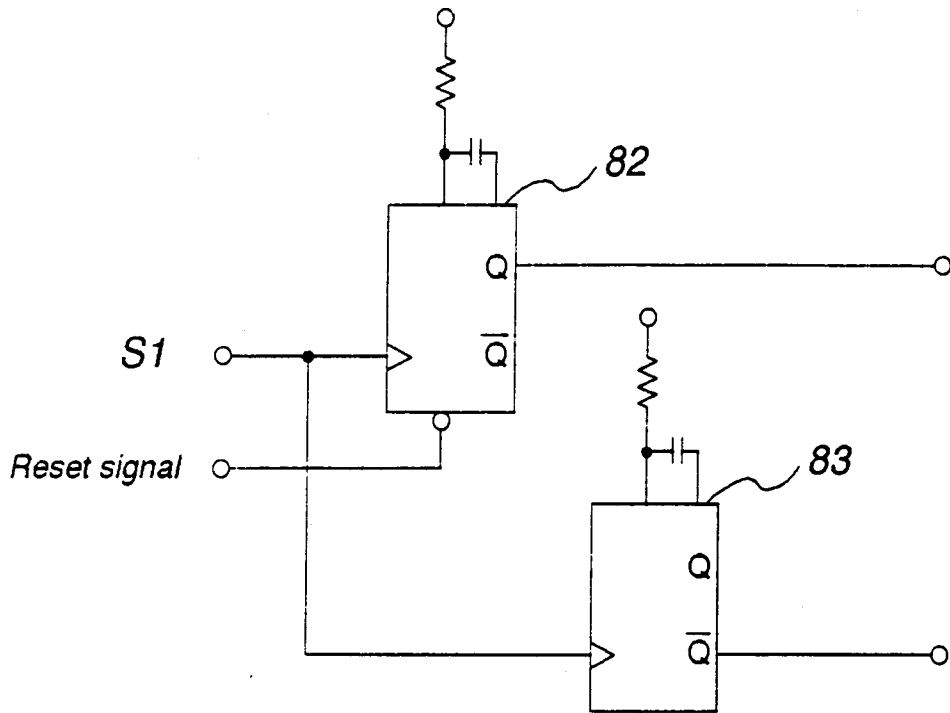

FIG. 12

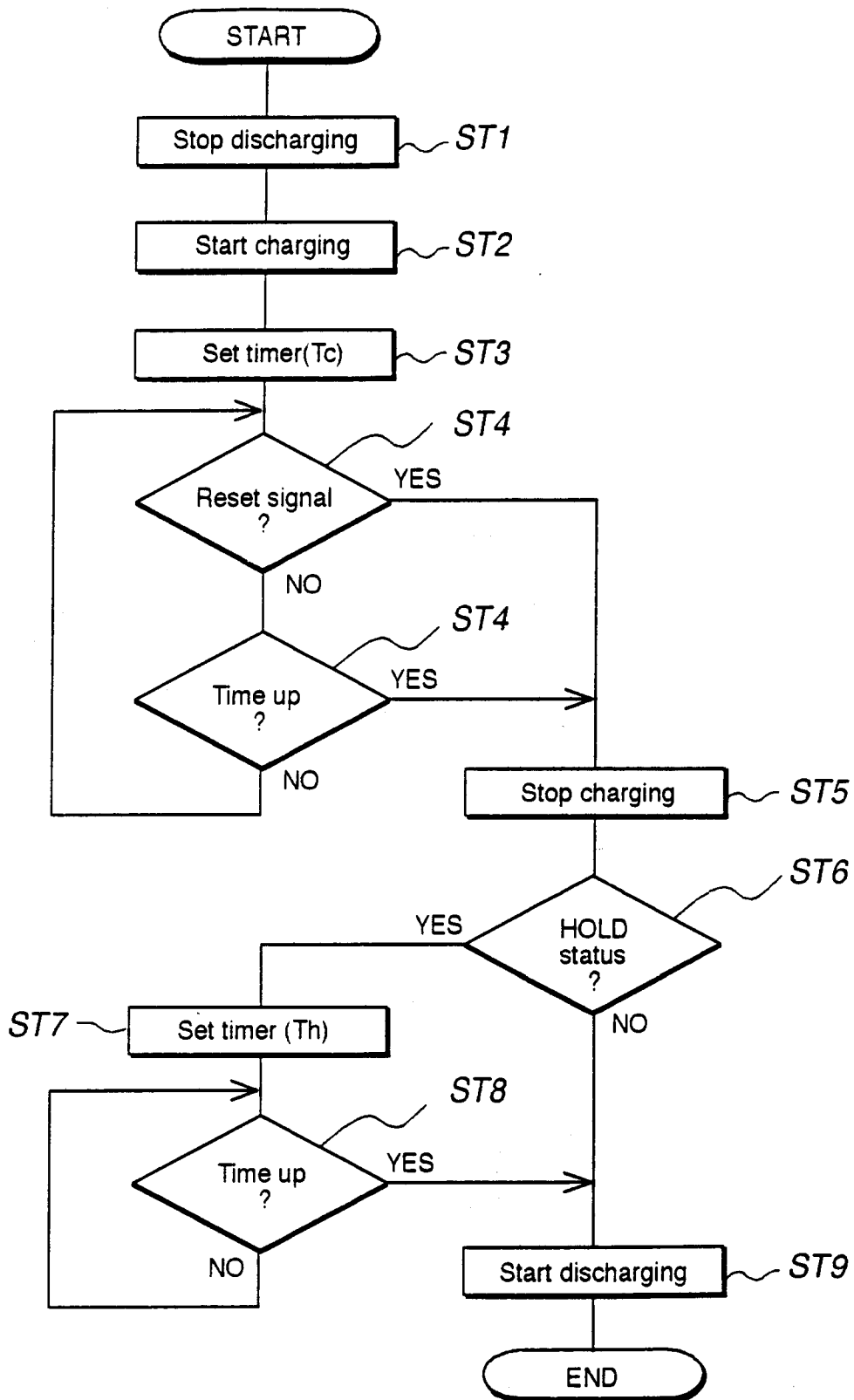

FIG.13

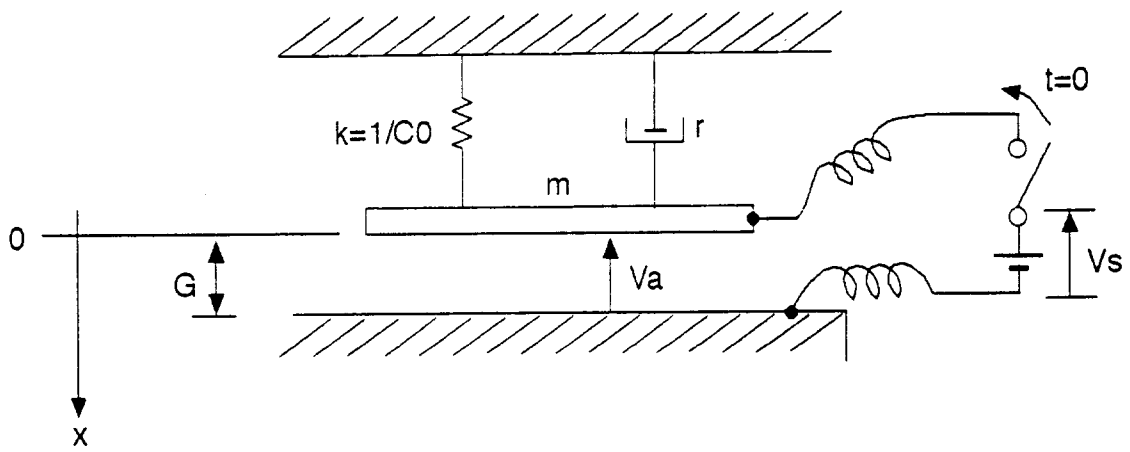

FIG. 14

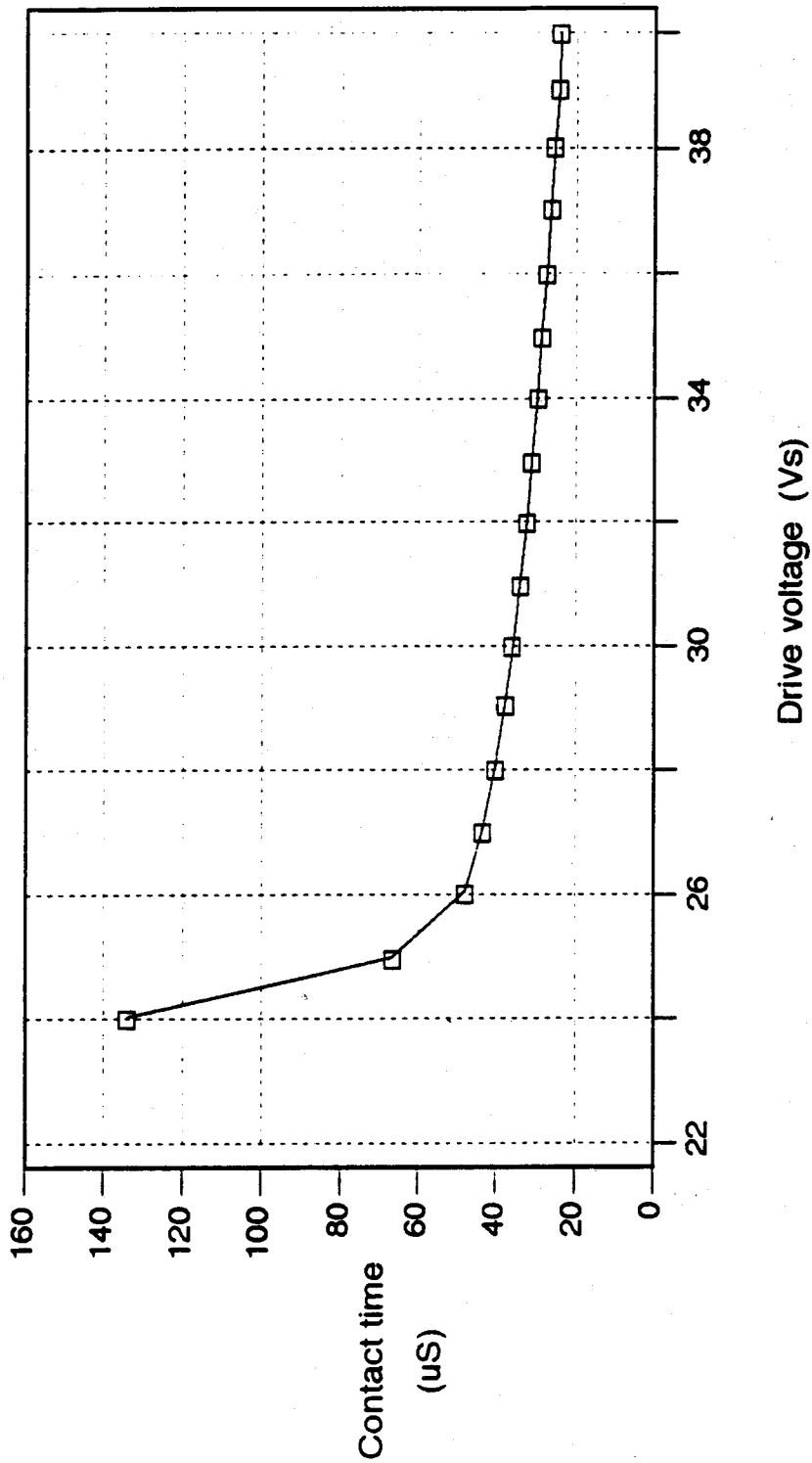

FIG. 15

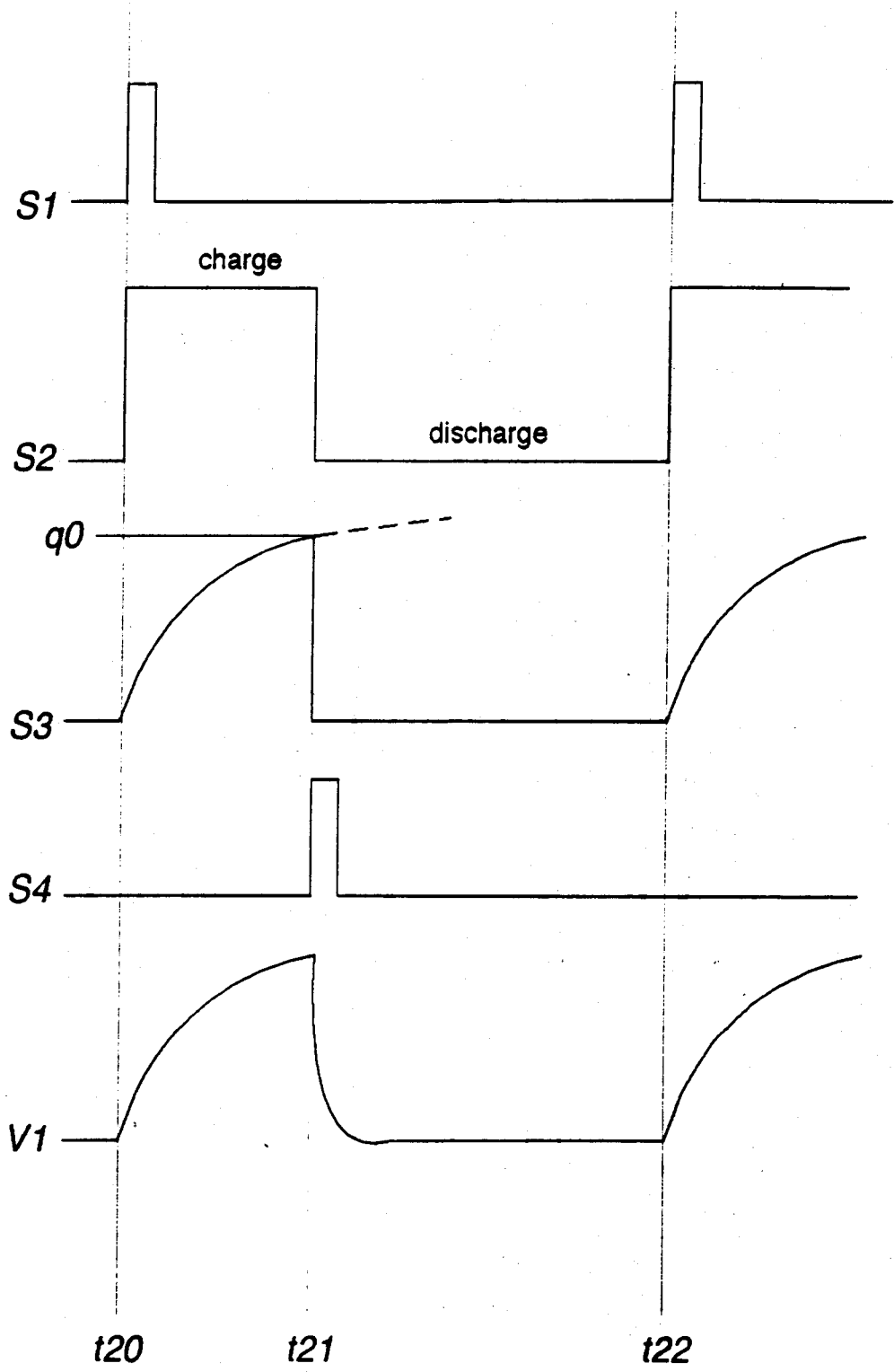

FIG.16

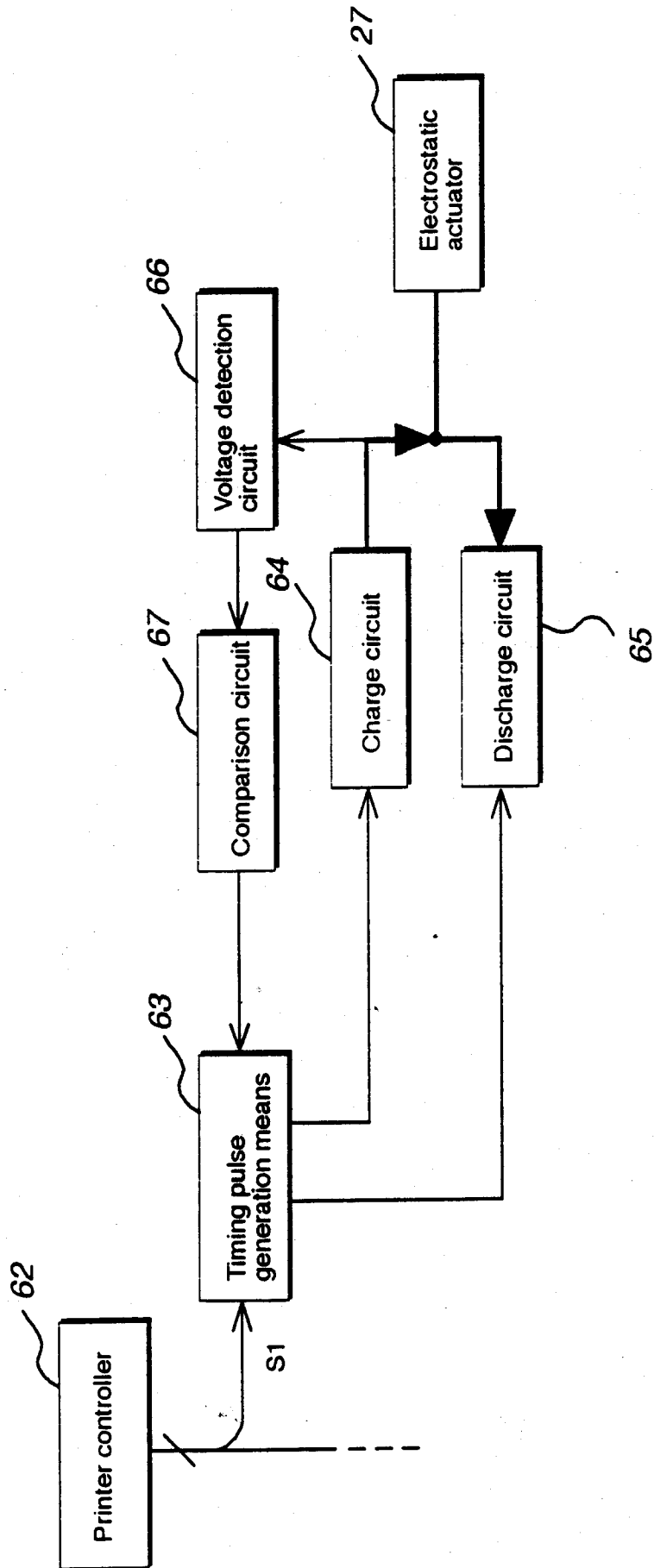

FIG. 17

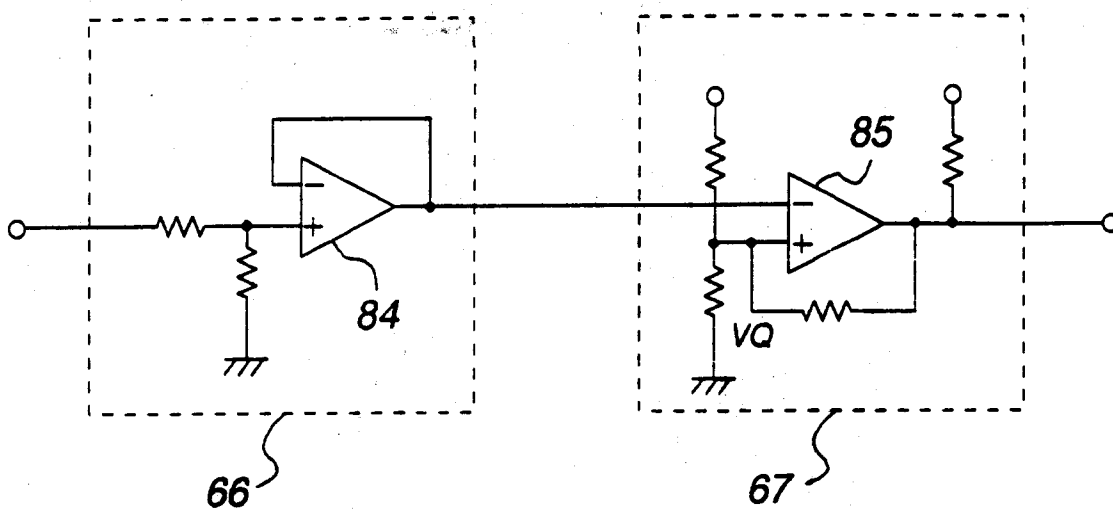

FIG. 18

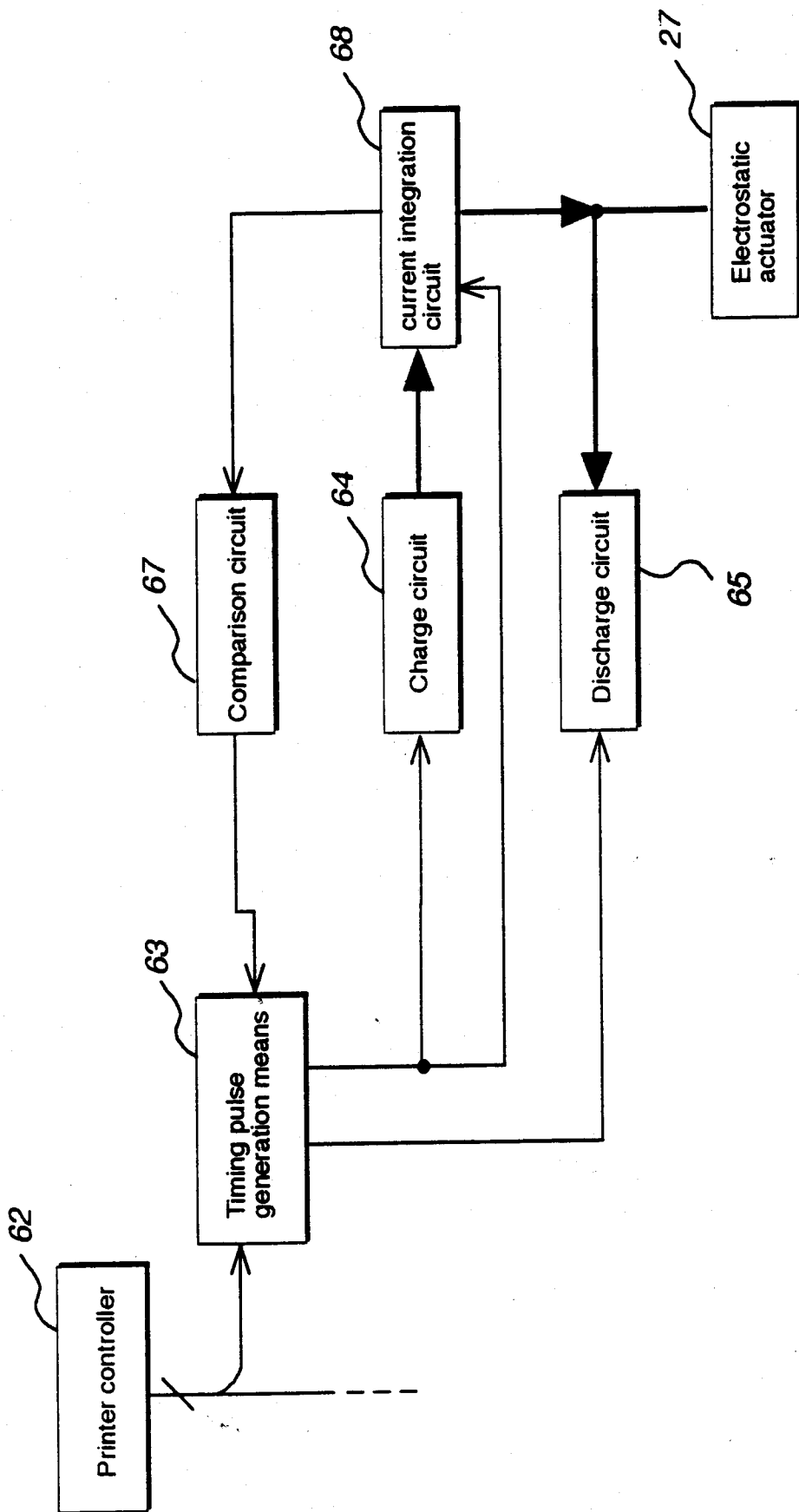

FIG. 19

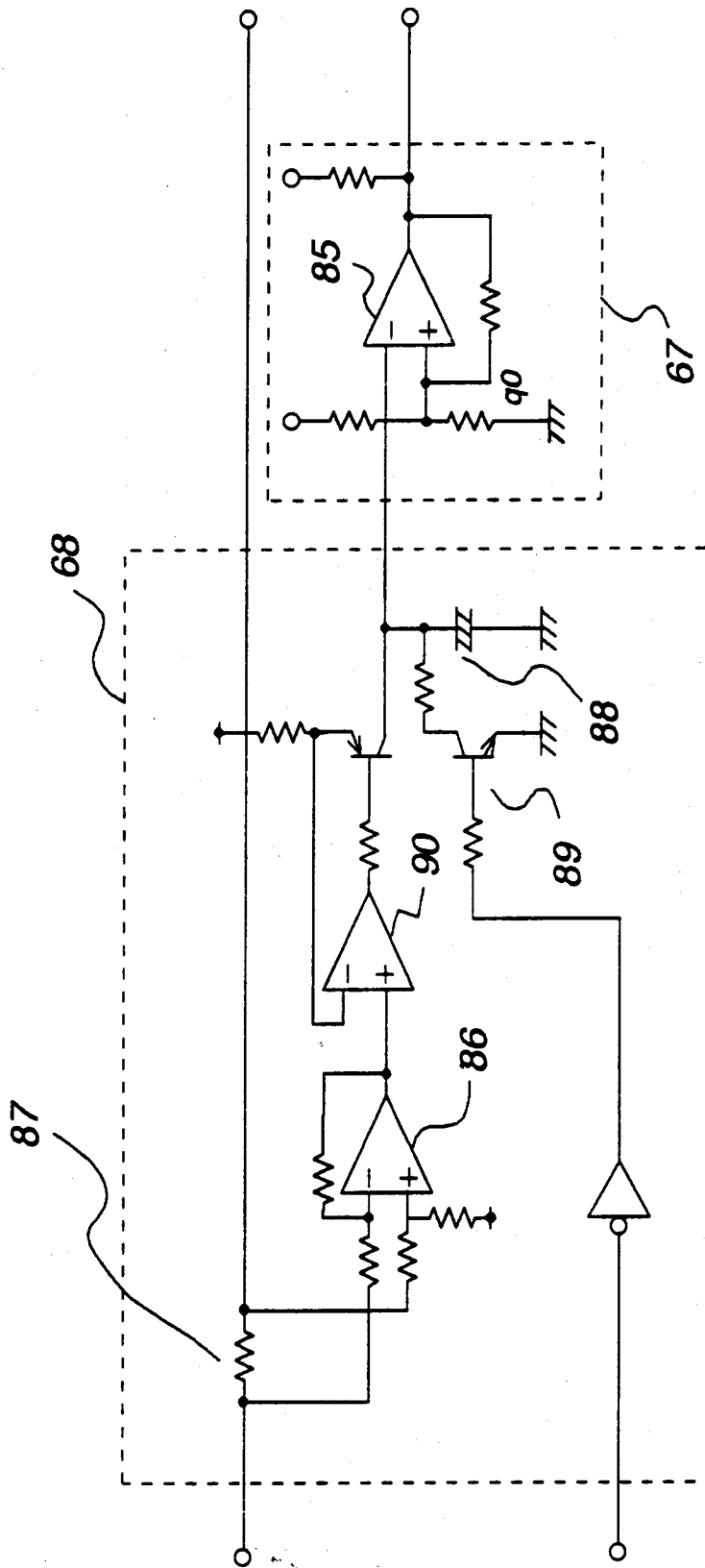

FIG. 20

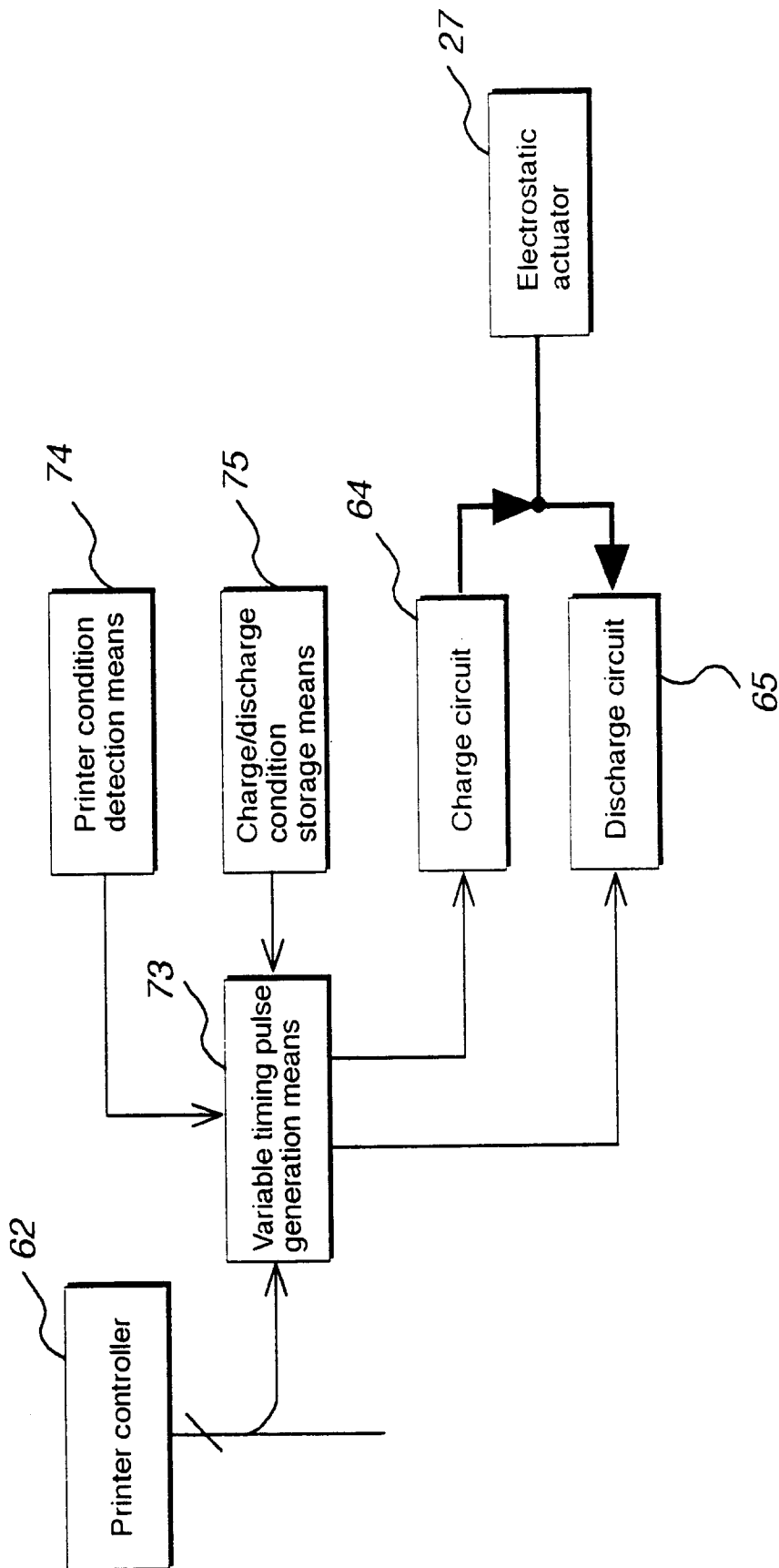

FIG. 21

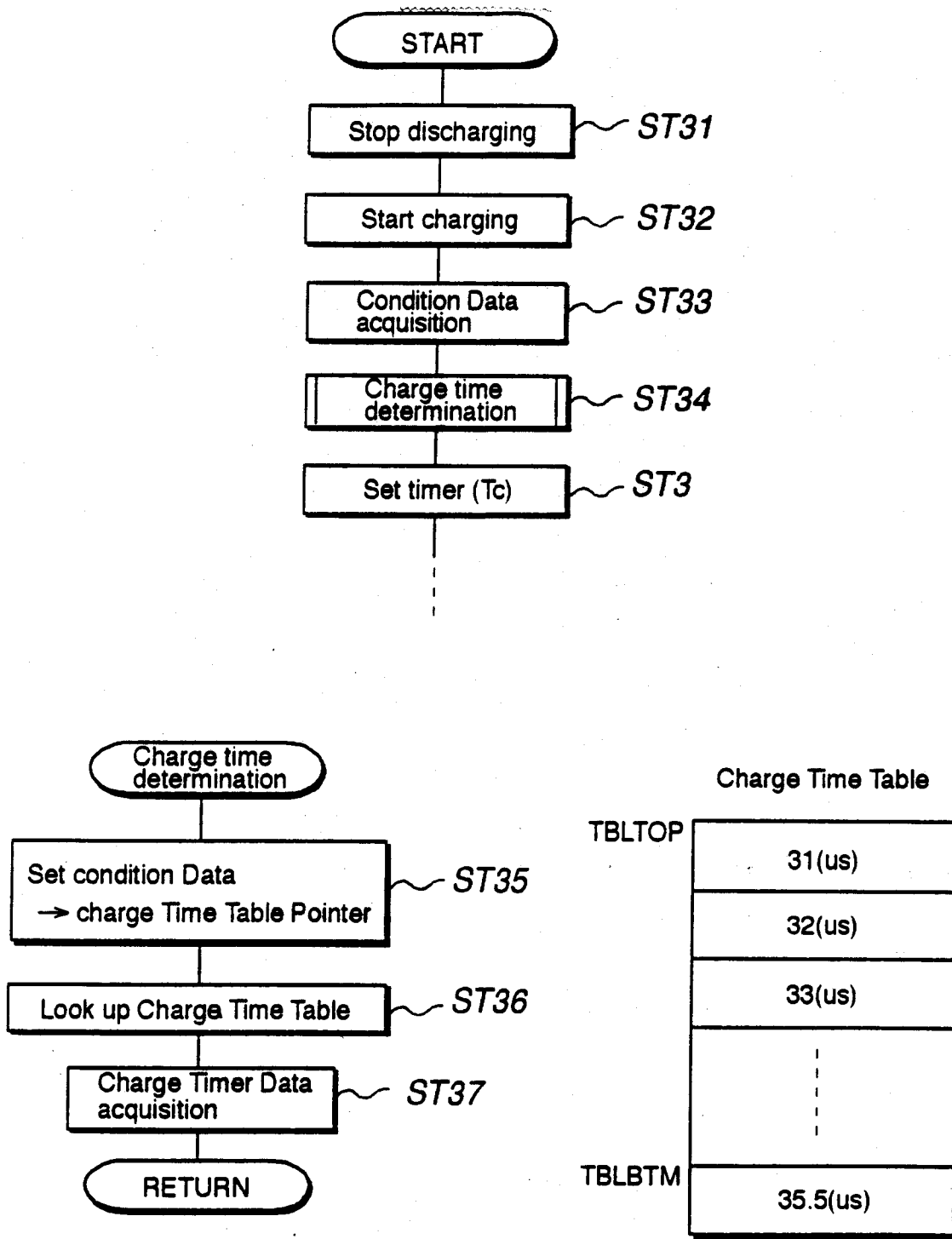

FIG. 22

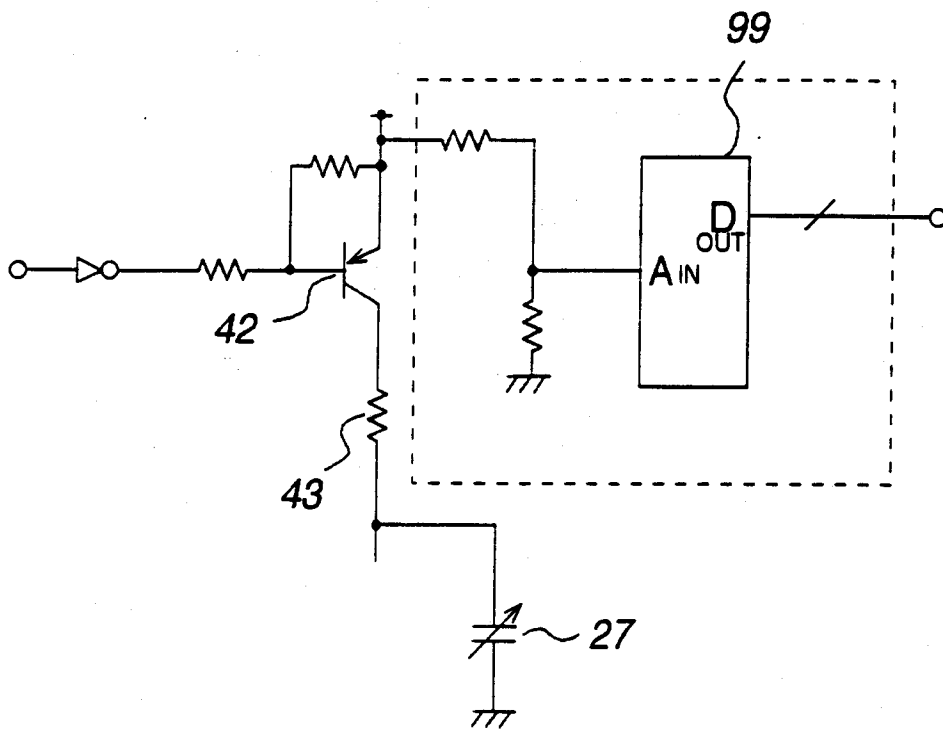

FIG. 23

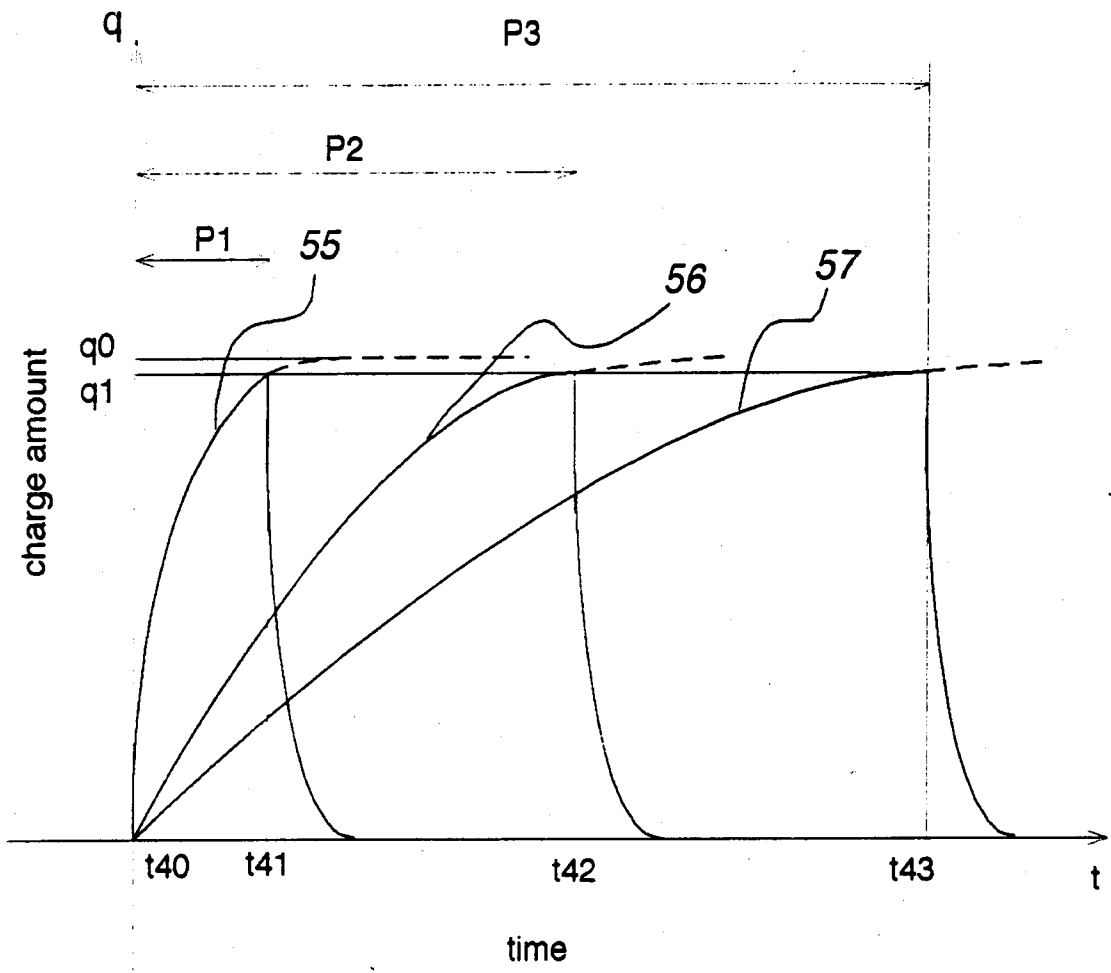

FIG.24

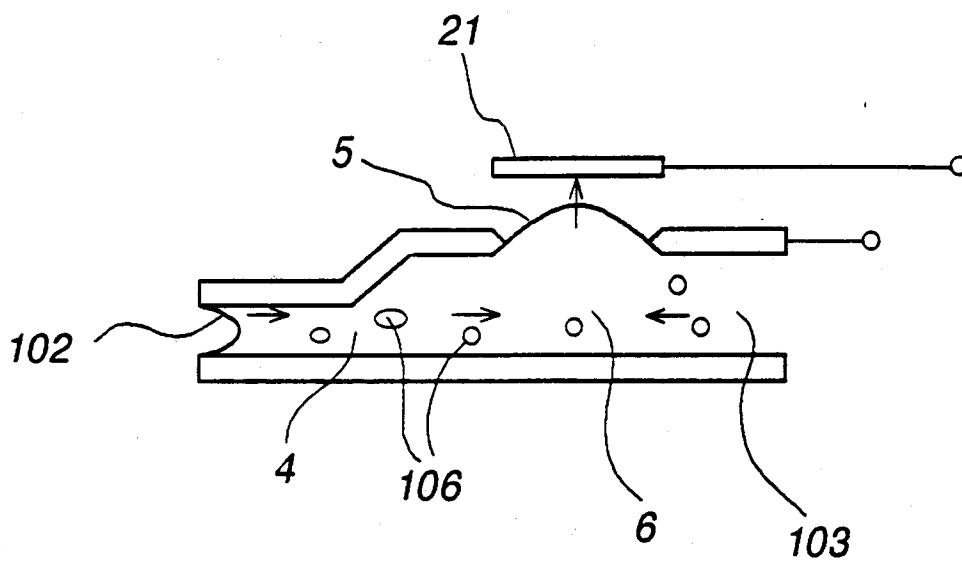

FIG. 25

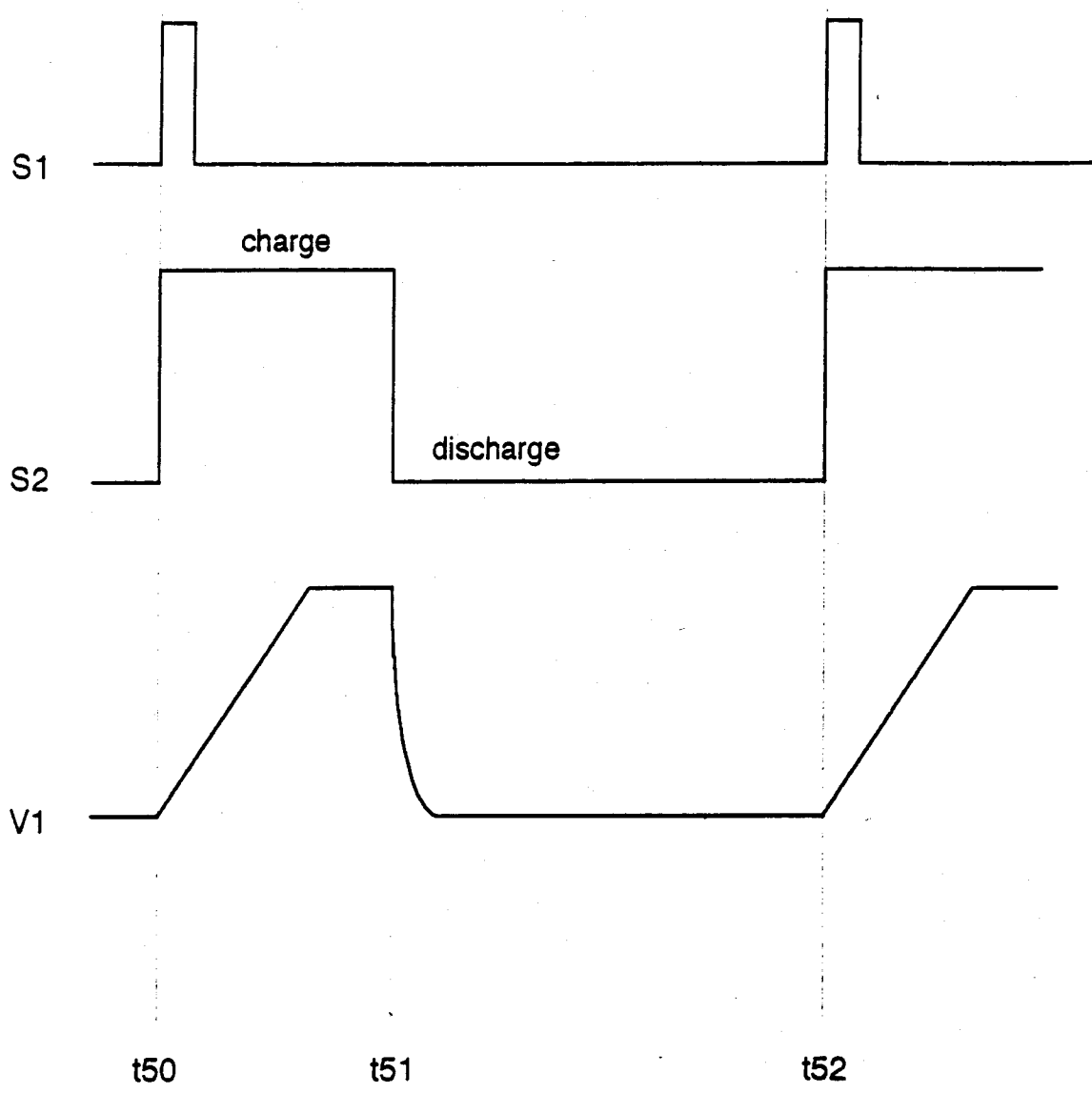

FIG.26

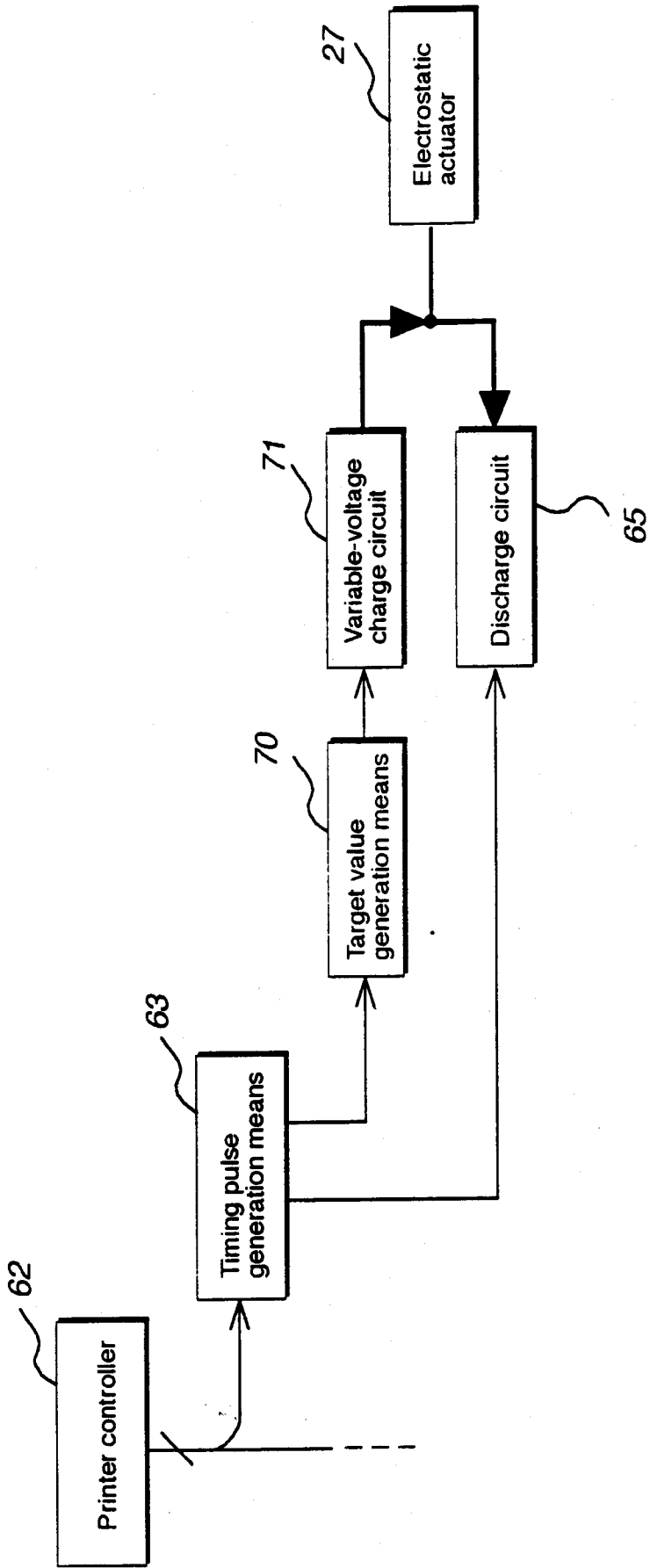

FIG. 27

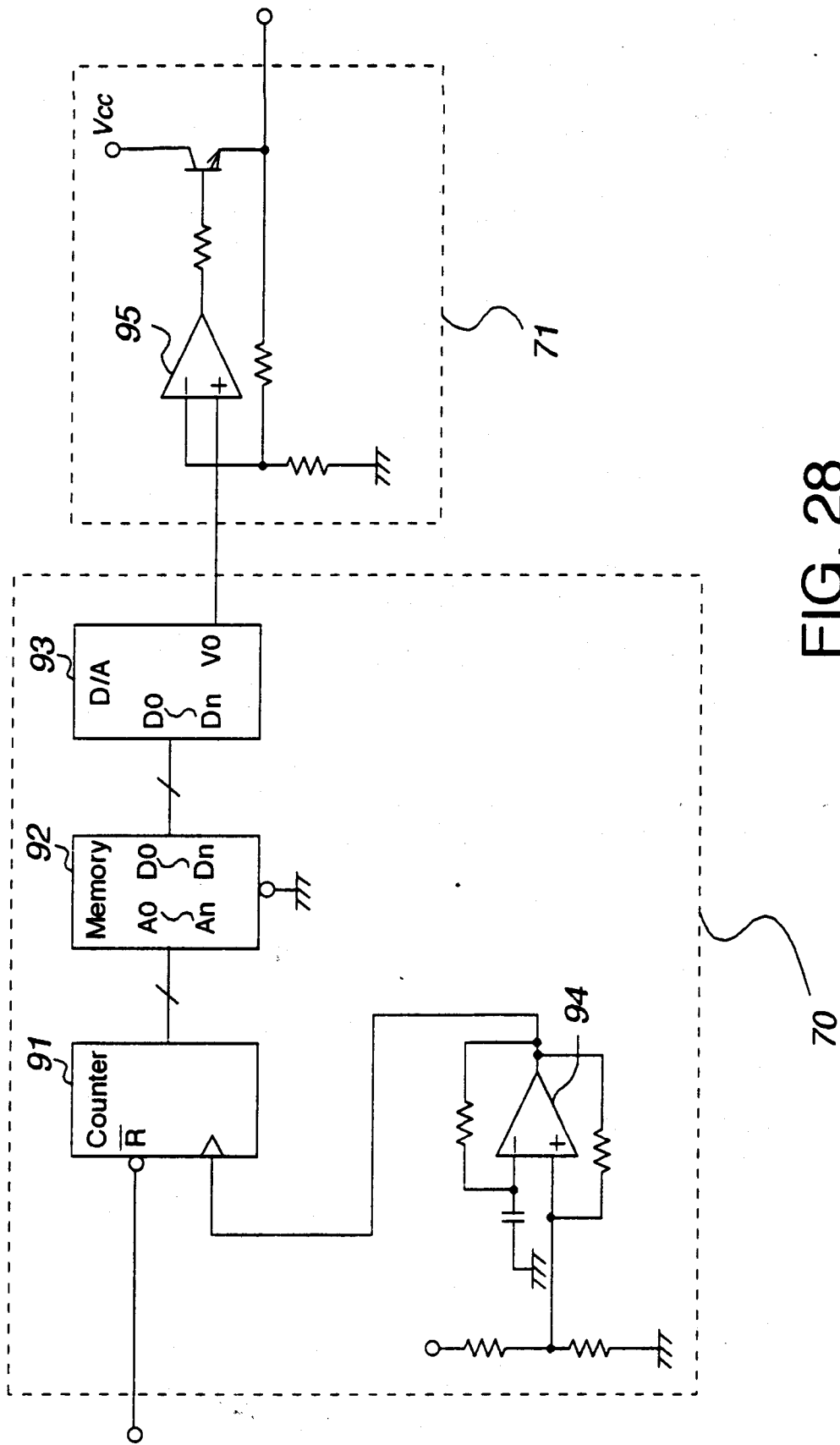

FIG. 28

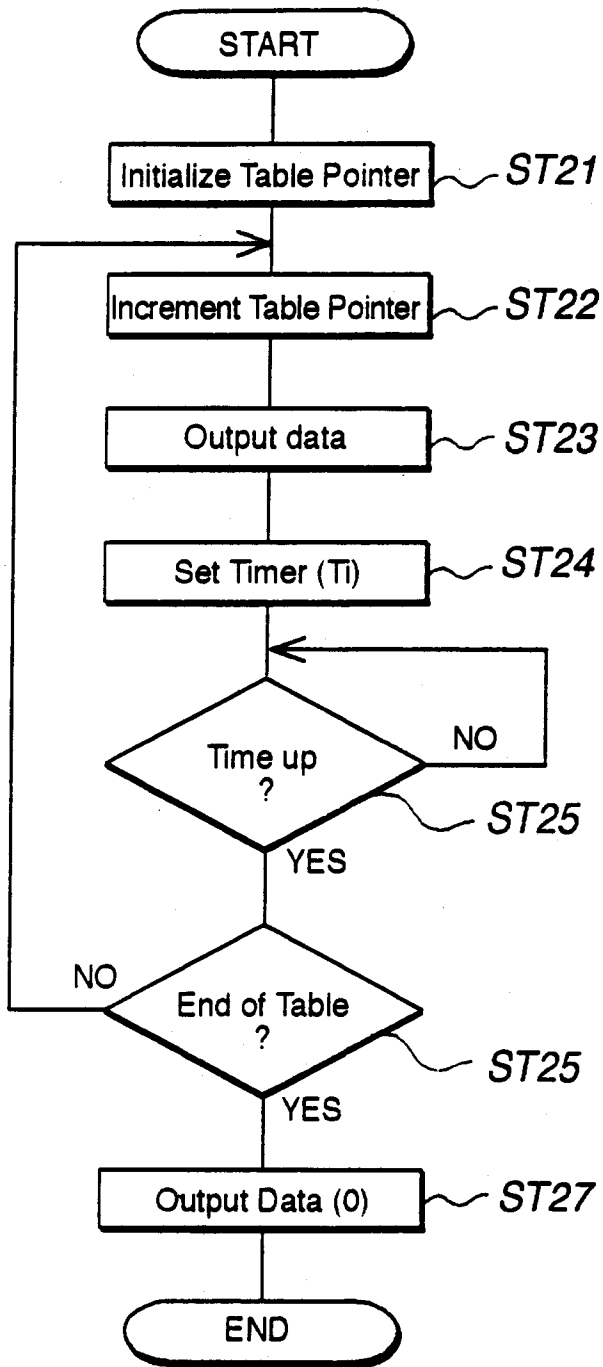

FIG.29

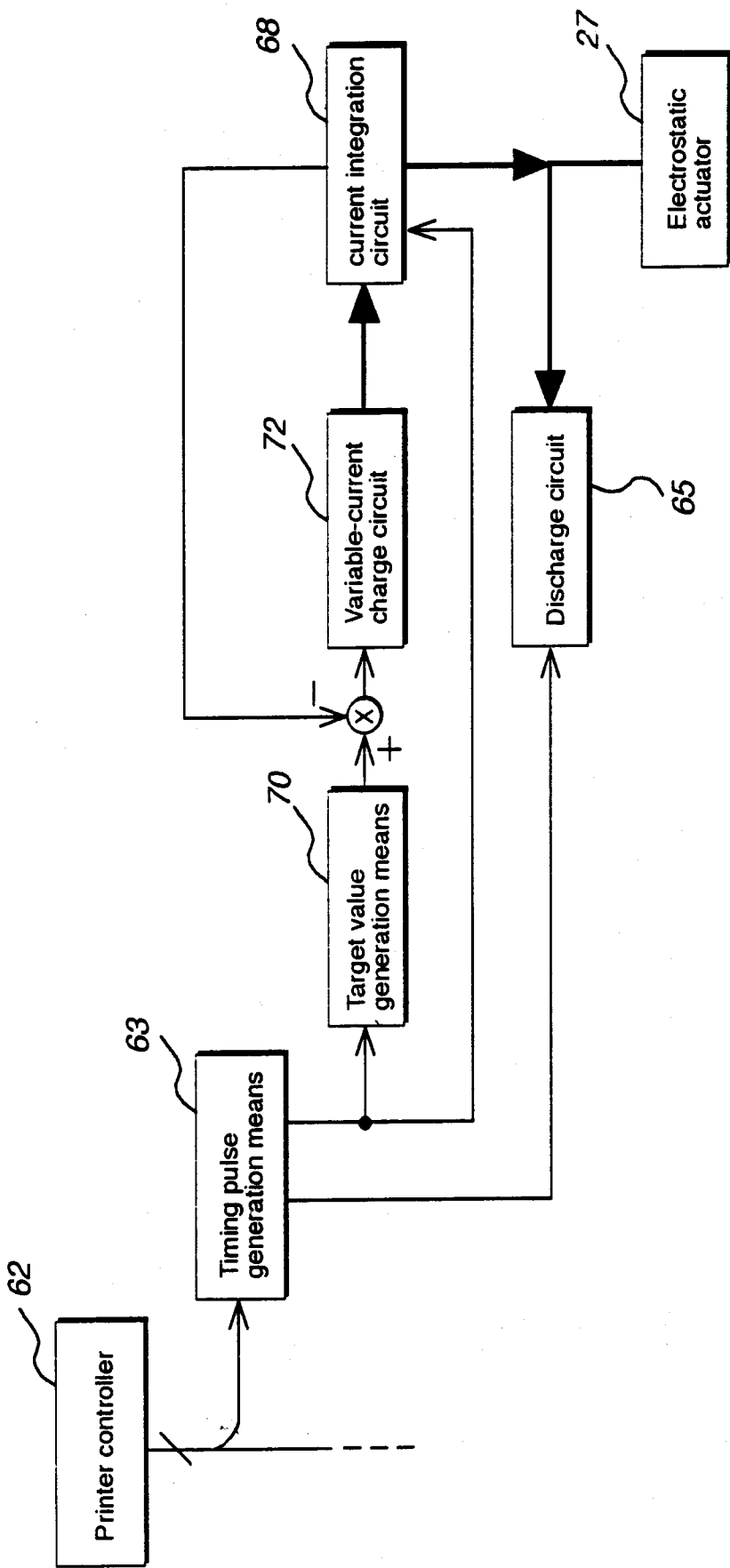

FIG. 30

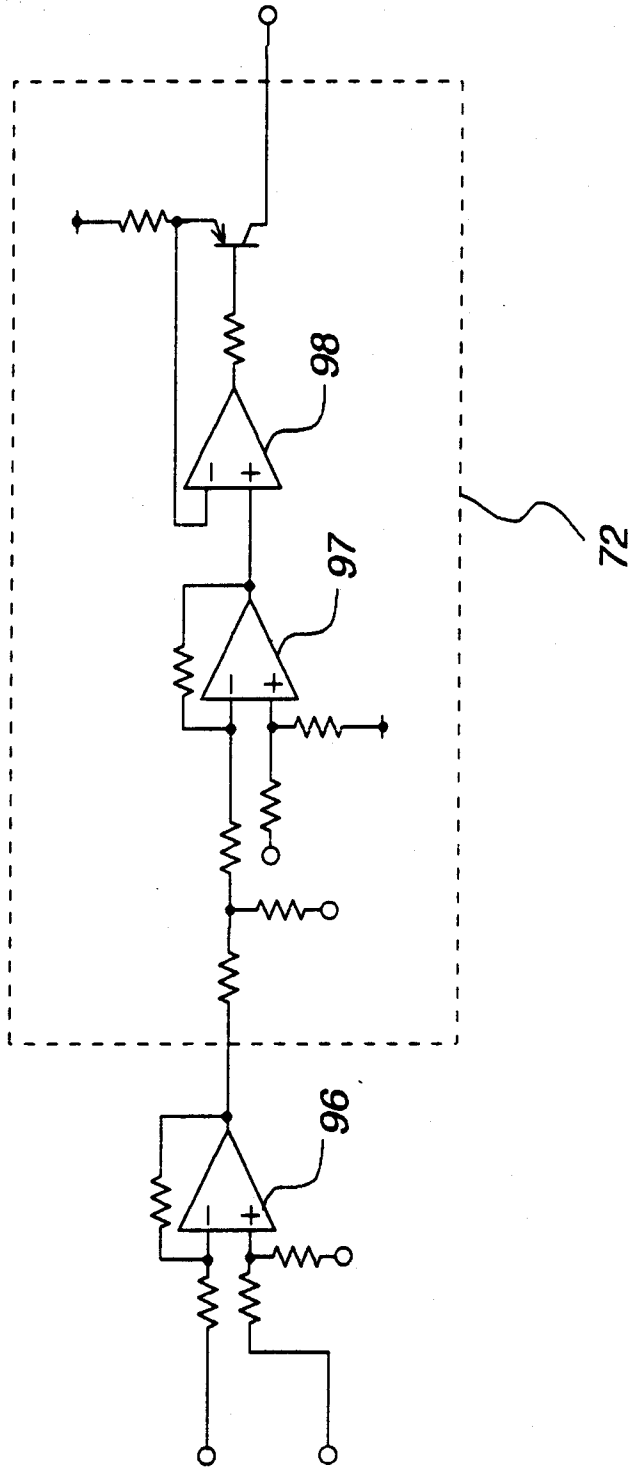

FIG. 31

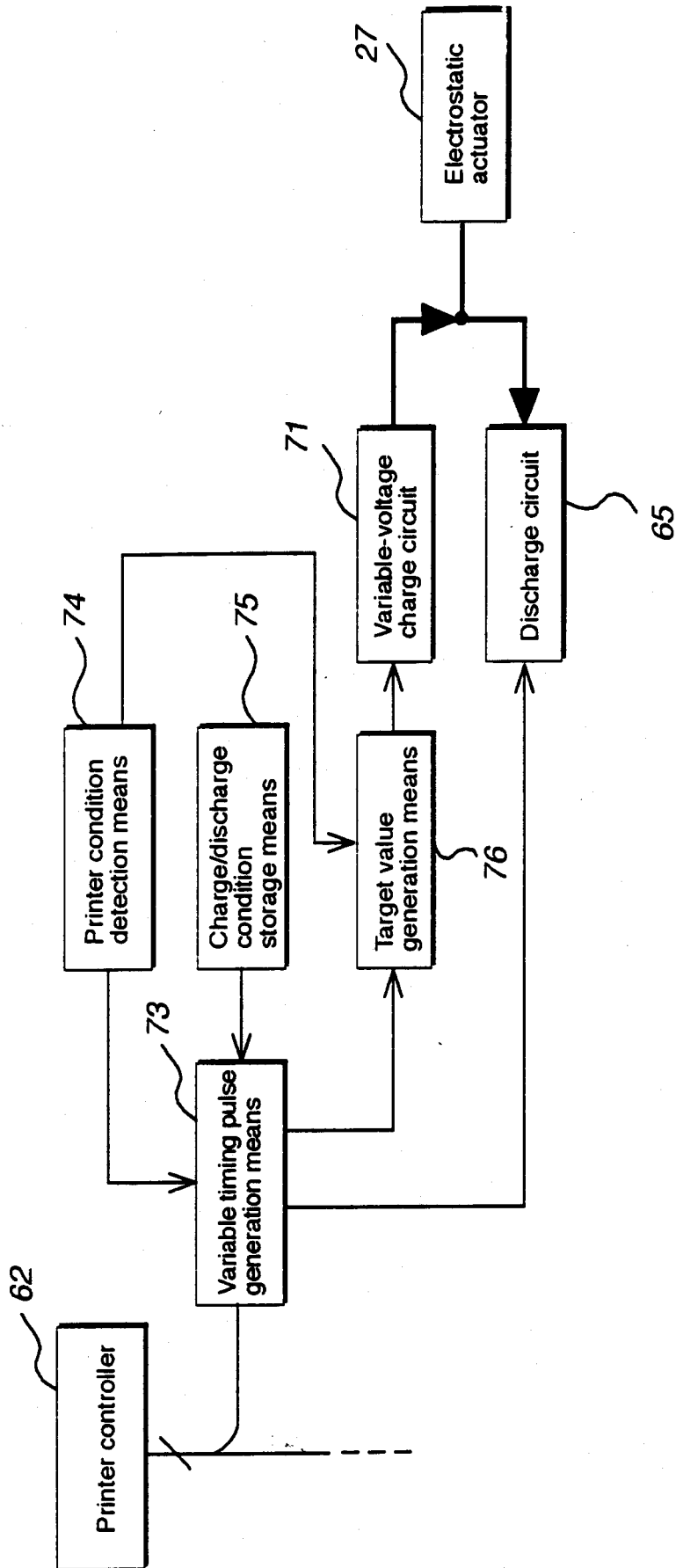

FIG. 32

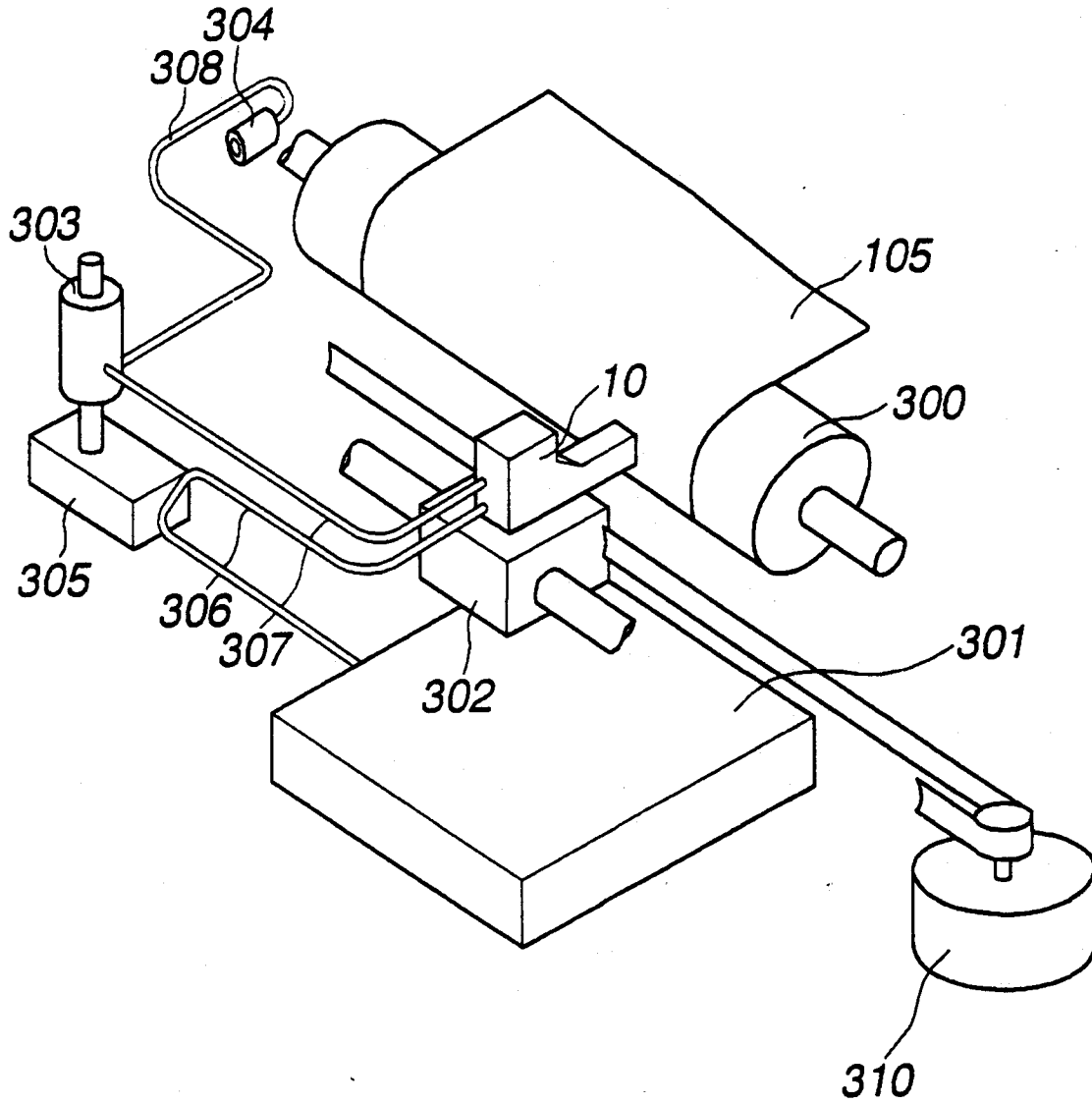

FIG. 33

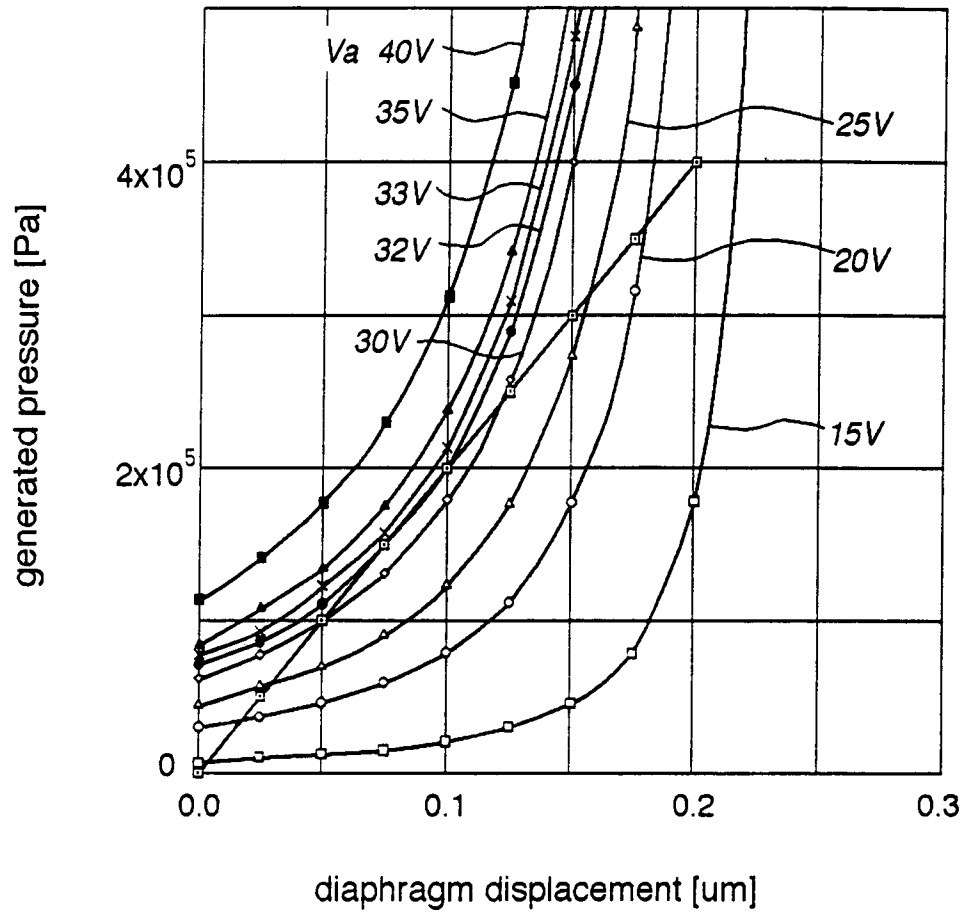

FIG. 34

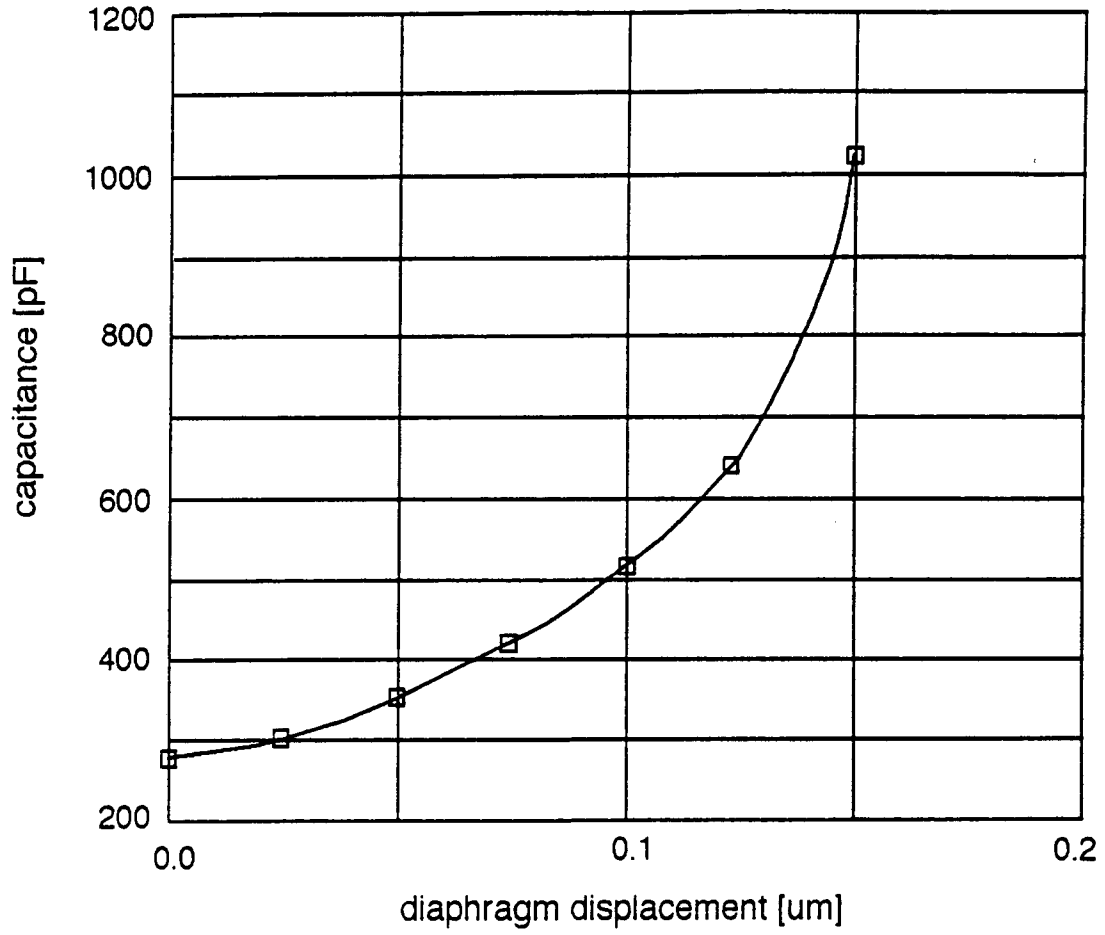

FIG. 35