

(No Model.)

3 Sheets—Sheet 2.

F. A. KIRBY & J. HENNING.
FLANGING MACHINE.

No. 526,714.

Patented Oct. 2, 1894.

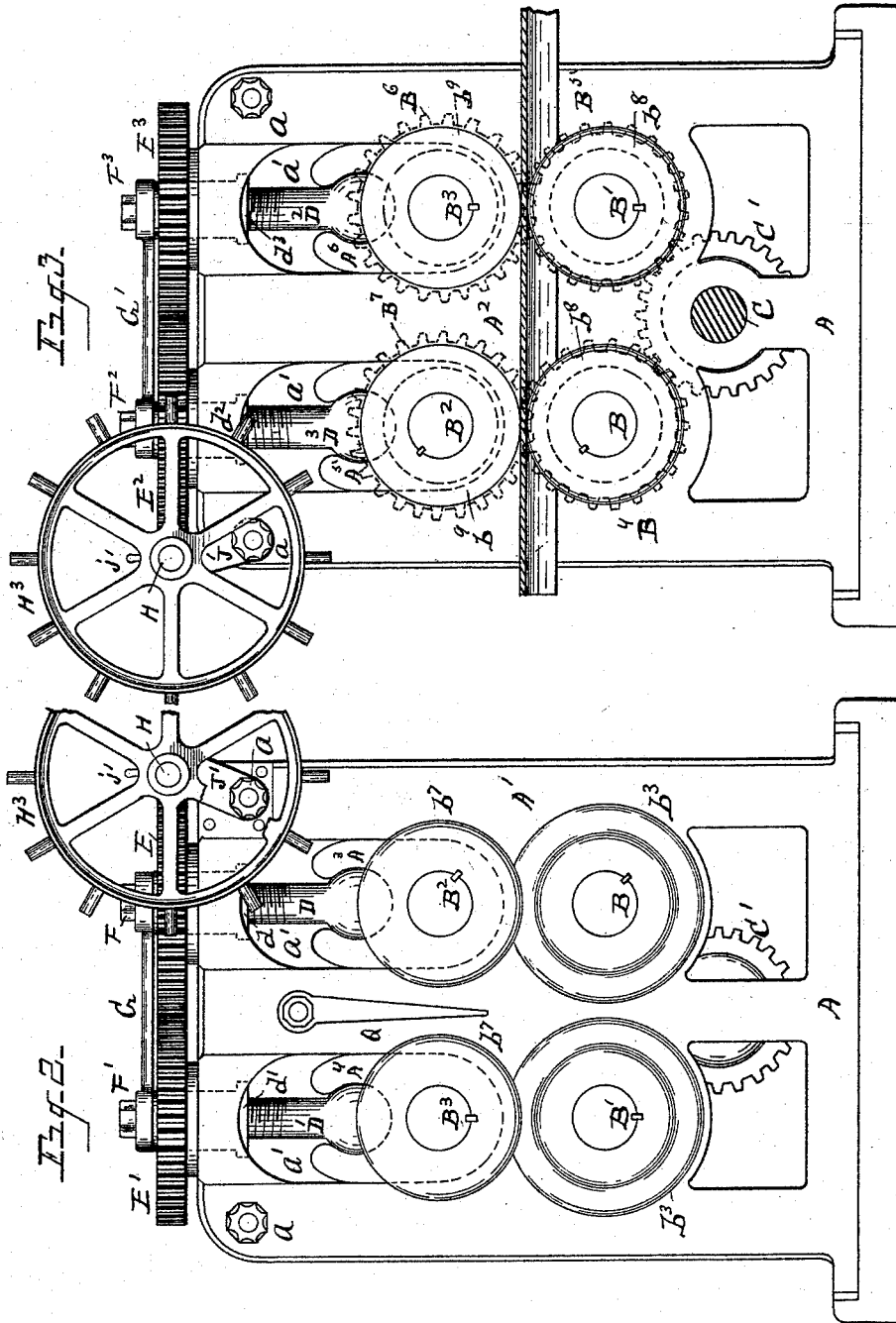

WITNESSES.

Otto Baenziger.
Harry R. Wheeler.

INVENTORS
Fitz A. Kirby
James Henning
By Maxwell S. Wright
Their Attorney.

UNITED STATES PATENT OFFICE.

FITZ A. KIRBY AND JAMES HENNING, OF WYANDOTTE, MICHIGAN.

FLANGING-MACHINE.

SPECIFICATION forming part of Letters Patent No. 526,714, dated October 2, 1894.

Application filed October 2, 1893. Serial No. 486,940. (No model.)

To all whom it may concern:

Be it known that we, FITZ A. KIRBY and JAMES HENNING, citizens of the United States, residing at Wyandotte, county of Wayne, State of Michigan, have invented certain new and useful Improvements in Flanging-Machines; and we declare the following to be a full, clear, and exact description of the invention, such as will enable others skilled in the art to which it appertains to make and use the same, reference being had to the accompanying drawings, which form a part of this specification.

Our invention has for its object a cold plate flanging and angle opening and closing machine, of superior construction and efficiency and it consists of the construction, combination and arrangement of devices and appliances hereinafter described and claimed, and illustrated in the accompanying drawings, in which—

Figure 1 is a side elevation. Fig. 2 is an end elevation looking toward the flanging rolls on the left of Fig. 1. Fig. 3 is a view of the opposite end. Fig. 4 is a plan view. Fig. 5 is a detail view in vertical section through the flanging rolls b^3 and b^7 on the shafts B^1 and B^2 . Fig. 6 is a detail view in vertical section through one of the nuts of one of the screw shafts. Fig. 7 is a detail in vertical section through the bushing of the operating shaft, and adjacent bearing.

Our invention is especially adapted and designed to provide an improved flanging machine for flanging metal plates, used in ship-building, although we do not limit ourselves to any definite purpose to which the machine may be applied. It is well understood that in ship-building, metal plates are required to be flanged in various ways and in various forms. Our invention contemplates a machine capable of straight plate flanging, also for forming flanges of hollow or rounding forms, and also by which a flange may be bent at any desired angle, closing or opening at any desired bevel, and by which the angle can be varied, as desired, as the plate passes through the machine.

To these ends we carry out our invention, as follows:

A denotes any suitable supporting frame which may be provided with stay-rods "a" extending longitudinally of the machine.

The frame is constructed with housings A^1 and A^2 in which are shown engaged lower rotatable shafts B and B' , upon each of which is mounted a series of flanging rolls b, b', b^2 , between the housings, and flanging rolls b^3 , on one extremity of each shaft outside the adjacent housing. The lower shafts are shown immovable vertically. Above the shafts B, B' are located corresponding shafts B^2 and B^3 , each provided with corresponding flanging rolls b^4, b^5, b^6 between the housings, and with a flanging roll b^7 outside the housing, the latter corresponding to the flanging roll b^3 there-beneath. One upper shaft with the lower shaft there-beneath, provided with the flanging rolls thereupon, form a set, two sets being shown, the one at the right hand and the other at the left hand in Fig. 2. The upper and lower shafts are also provided, preferably, at their outer extremities opposite the flanging rolls b^3 and b^7 , with straightening rolls b^8 and b^9 .

C is a driving shaft which may be provided with a gear C' , said gear meshing with gears B^4 and B^5 upon the two lower shafts B, B' respectively. The gear B^5 meshes with a gear B^6 on the corresponding upper shaft B^3 , and the gear B^4 meshes with a gear B^7 on the corresponding upper shaft B^2 . We do not, however, limit ourselves to any specific mechanism for driving the shafts with their flanging rolls.

The upper shafts B^2 and B^3 , with their flanging rolls, are shown as made vertically movable. To this end they are each provided with bearings A^3 and A^4 , at the forward end, and with similar bearings at A^5 and A^6 , at their opposite ends, said bearings being vertically movable in suitable elongated orifices a' , in the housing. Connected with each of these bearings is a screw threaded shaft D, D', D^2 and D^3 , respectively. These screw threaded shafts are provided toward their upper ends with corresponding nuts d, d', d^2 and d^3 , in which the corresponding screw threaded shafts work. With the nuts, are engaged corresponding adjusting gears $E, E',$

E² and E³, whereby they may be operated. To prevent the screw shafts from turning with the nuts, their upper ends may be formed with annular extremities, as shown at F, F', F² and F³.

G and G' denote wrenches, upon the extremities F, F', F², and F³, respectively, to hold the screw shafts from turning.

H denotes an adjusting shaft extending longitudinally of the machine, provided with a worm gear toward each end, as shown at H' and H², the worm H² in Fig. 1 being broken away to show the gear E². The worm gear H' meshes with one of the adjusting gears on the corresponding nut, which gears mesh one with the other. The worm gear H² meshes with one of the adjusting gears at the opposite end of the machine, which said gears also mesh the one with the other.

The operating shaft H may be provided with a hand wheel, or other suitable device preferably at each end thereof, as shown at H³. Obviously, the two screw shafts, at each end of the machine, will be constructed the one with right hand and the other with left hand screw-threads. By this means the upper set of rolls may be readily adjusted vertically in a convenient and speedy manner.

It will be evident that by removing the wrenches G, G', the screw shafts can be properly adjusted in their corresponding nuts to suit the work, when the wrenches may be re-applied. By turning one of the hand-wheels H³, both of the upper sets of flanging rolls may be vertically adjusted simultaneously. The left hand upper flanging roll, *i. e.*, roll b⁷ on the shaft B³ needs to be turned down a little lower than the corresponding upper roll in front thereof, in operation, to make the two rolls each do their work successively. The work will be introduced to the flanging rolls b³, b⁷ from the right hand of Fig. 2.

To throw the operating shaft H and its worm gear out of mesh with the adjacent adjusting gears upon the nuts "d," d', d², d³, the operating shaft may be provided with a bushing J within the bearing J', of said shaft, the bushing being eccentrically connected with the operating shaft within the bearing. It will be evident that by turning this bushing about on either end of the operating shaft, either or both corresponding worm gears will be thrown into or out of mesh with the corresponding adjusting gears. The bushing may be operated for this purpose in any suitable manner. For example, the bearing J' may be constructed with an elongated arc-shaped slot j and the bushing be provided with a bar or lever j' passing through said slot, whereby the bushing may be rotated, the ends of said slot limiting the rotation of said bushing.

For hollow and round flanging, the two left hand flanging rolls b³ and b⁷, of Fig. 2, forming one set of rolls, should be loosely mounted

upon their corresponding shafts B', B³, and constructed to have a longitudinal play thereupon corresponding to the curve of the flange, as indicated in Fig. 5. For straight flanging, no longitudinal movement is required.

Our flanging machine, as above observed, is designed and adapted especially for flanging metal plate, cold. It is well understood that the heating of such plates, to flange them, injures the plate, and that flanging them cold by hand, in the ordinary manner, is a very slow process. By our invention, however, the plates can be flanged cold in a very efficient and speedy manner. To get the degree of flanging required, or the desired angle, it will be necessary to run the plate several times through the machine, tightening down the outer upper flanging rolls at each time the plates are run there-through.

Usually the plates will be marked on a line at which the flange is to be bent, and we design to provide the outer frame with an indicator finger Q to facilitate the guiding of the plate through the rolls on the line so marked.

It will be perceived that the V-rolls are on the lower shafts, as shown in the drawings, but the arrangement might be reversed within the scope of our invention. The flanging rolls between the uprights of the frame are designed more particularly for shaping angle iron to required forms. While we have shown two sets of lower and upper shafts, with their flanging rolls, the machine would be operative with a single set of rolls, that is, a single lower shaft with a single upper shaft with their corresponding rolls.

It will be perceived that the V-shaped flanging rolls exert their pressure to effect the desired flanging, on the line previously laid out, as above described, at the apex of the angle to be formed. For different thicknesses of plate it will be found desirable to substitute, upon the corresponding shafts, flanging rolls of suitable form in order not to exert too severe a pressure upon the plate. The outer flanging rolls therefore can be made removable so that any desired form of roll may be applied upon the corresponding shaft to suit the work required.

The threaded shafts D, D', D² and D³ are shown constructed with spherical heads at their lower ends correspondingly seated in the bearings A³, A⁴, A⁵ and A⁶. This forms a ball and socket joint at this point of construction. One set of flanging rolls is made V-shaped meshing with the corresponding rolls of inverted V-shape.

What we claim as our invention is—

1. A flanging machine having in combination a supporting frame, and a set of rotatable shafts provided at one of their extremities with corresponding flanging rolls b³ and b⁷, one of said shafts made adjustable, and

said flanging rolls having a longitudinally reciprocatory movement upon said shafts, substantially as set forth.

2. A flanging machine having in combination a supporting frame, a series of rotatable shafts provided at one of their extremities with flanging rolls b^3 and b^7 thereupon, and an additional series of rotatable shafts having corresponding flanging rolls thereupon, one series of said shafts made adjustable, and one set of flanging rolls having a longitudinally reciprocatory movement upon their corresponding shafts, substantially as set forth.

3. A flanging machine having in combination a supporting frame provided with housings, a lower set of rotatable shafts provided with flanging rolls at their extremities outside their housings, and an upper set of rotatable shafts provided with flanging rolls outside their housings and made adjustable, one set of flanging rolls having a longitudinally reciprocatory movement upon their corresponding shafts, substantially as set forth.

4. In a flanging machine, the combination of the supporting frame, the lower set of rotatable shafts provided with flanging rolls, and an upper set of rotatable shafts provided with flanging rolls and made vertically adjustable, one set of said flanging rolls being longitudinally movable on their corresponding shafts said shafts at one of their extremities provided with straightening rolls,—substantially as set forth.

5. In a flanging machine the combination of the supporting frame constructed with elongated orifices a' , a lower set of rotatable shafts provided with flanging rolls, an upper set of rotatable shafts provided with flanging rolls bearings for one set of shafts vertically adjustable in said elongated orifices in the frame, vertical threaded shafts connected with said bearings, means to prevent said vertical threaded shafts from turning, adjusting nuts engaging said threaded shafts, adjusting gears for adjusting said nuts, and an operating shaft geared with the adjusting gears, substantially as set forth.

6. In a flanging machine, the combination of the supporting frame, the lower set of rotatable shafts provided with flanging rolls, an upper set of rotatable shafts provided with flanging rolls, bearings in which the upper set of shafts are journaled, having a vertical movement in said frame, threaded shafts connected with said bearings, nuts engaging said threaded shafts, adjusting gears for adjusting said threaded shafts and an operating gear geared to the adjusting gears and means

for throwing said operating shaft out of engagement with the adjusting gears, substantially as set forth.

7. A flanging machine for cold plate flanging having in combination two sets of rotatable V-shaped rolls mounted upon their respective shafts and meshing with correspondingly grooved rotatable rolls, said rolls being adjustable vertically the one relative to the other, one of the said V-shaped rolls and its corresponding grooved roll having a longitudinally reciprocatory movement upon their respective shafts, substantially as set forth.

8. A flanging machine having in combination a supporting frame, a lower set of rotatable shafts provided with flanging rolls, an upper set of rotatable shafts provided with flanging rolls, bearings for one set of said shafts vertically adjustable in said frame, vertical threaded shafts having a jointed connection with said bearings, means to prevent the turning of said vertical threaded shafts, adjusting nuts engaging said threaded shafts, adjusting gear for adjusting said nuts, the shaft of the adjusting gear provided with a bearing J' , and a bushing J eccentrically connected to the shaft of the adjusting gear within said bearing, substantially as set forth.

9. A flanging machine having in combination a supporting frame, a series of rotatable shafts provided with flanging rolls, and additional series of rotatable shafts provided with flanging rolls, one series of said shafts made adjustable, and wrenches to hold the said shafts in adjusted position, substantially as set forth.

10. In a flanging machine the combination of a supporting frame provided with housings A' , A^2 , a lower set of rotatable shafts, each provided with flanging rolls located between said housings, and with a flanging roll at one extremity outside of said housings, an upper set of rotatable shafts each provided with flanging rolls located between said housings, and a flanging roll at one extremity outside the housings, and means for adjusting one set of said shafts, one of the upper and one of the lower flanging rolls upon the outer extremities of their respective shafts having a longitudinally reciprocatory movement thereupon, substantially as set forth.

In testimony whereof we sign this specification in the presence of two witnesses.

FITZ A. KIRBY.
JAMES HENNING.

Witnesses:

N. S. WRIGHT,
H. R. WHEELER.