

(19) **DANMARK**

(10) **DK/EP 3237701 T3**



(12) **Oversættelse af
europæisk patentskrift**

Patent- og
Varemærkestyrelsen

-
- (51) Int.Cl.: **E 04 C 2/26 (2006.01)** **E 04 F 13/08 (2006.01)** **E 04 F 13/12 (2006.01)**
- (45) Oversættelsen bekendtgjort den: **2018-12-17**
- (80) Dato for Den Europæiske Patentmyndigheds bekendtgørelse om meddelelse af patentet: **2018-10-10**
- (86) Europæisk ansøgning nr.: **15841107.4**
- (86) Europæisk indleveringsdag: **2015-12-22**
- (87) Den europæiske ansøgnings publiceringsdag: **2017-11-01**
- (86) International ansøgning nr.: **NL2015050900**
- (87) Internationalt publikationsnr.: **WO2016105194**
- (30) Prioritet: **2014-12-24 NL 2014055**
- (84) Designerede stater: **AL AT BE BG CH CY CZ DE DK EE ES FI FR GB GR HR HU IE IS IT LI LT LU LV MC MK MT NL NO PL PT RO RS SE SI SK SM TR**
- (73) Patenthaver: **Insulation Solutions B.V., Minosstraat 40, 5048 CK Tilburg, Holland**
- (72) Opfinder: **Hendriks, Joannes Augustinus Antonius, Boslaan 37, 5263 GW Vught, Holland**
VERBOVEN, Michael Clasina Cornelis, Burgemeester Libourelstraat 5, 5165 TN Waspik, Holland
- (74) Fuldmægtig i Danmark: **HEGNER & PARTNERS A/S, Symbion Science Park, Fruebjergvej 3, 2100 København Ø, Danmark**
- (54) Benævnelse: **FREMGANGSMÅDE OG SAMLING TIL BEKLÆDNING ELLER AFDÆKNING AF BYGNINGER**
- (56) Fremdragne publikationer:
EP-A2- 0 896 106

DESCRIPTION

[0001] The invention relates to a method for cladding or covering buildings, in particular using mineral wool as an insulation layer.

[0002] Such a method is generally known. In the generally known method, a steel framework of a building is provided with a multitude of elongate cassettes. The cassettes are mounted above each other on the support, forming elongate, U-shaped sections. The sections are open in a direction away from the building; they each comprise an L-shaped section part. The long leg of the "L" extends horizontally as a leg of the U-shape of the section, with the short leg of the "L" extending vertically from the end of the long leg that faces away from the building. Such sections, which are generally known, are used in standard dimensions. A layer of insulation material, preferably mineral wool, is placed in and over the sections. Subsequently, cladding elements are installed on the insulation layer. When doing so, the user will first drill a screw through a cladding element and subsequently through the insulation layer into the short leg of the "L", which thus forms an engaging surface for the screw. A drawback of the generally known method is that the section with the "L" is not visible to the user, so that he or she must determine the location of the engaging surface by indirect means. It is thus difficult to accurately align the cladding elements that are mounted to the short leg of the "L" in an efficient manner.

[0003] A further drawback of the generally known method is that the insulation value of the cladding thus obtained is limited. The thickness of the insulation layer is limited and as a result also the insulation value of the cladding. Given the dimensions of the currently usual cassettes it is not possible, using the generally known method, to comply with the insulation standards that are in force as per 2015. In conformity with the "Bouwbesluit 2015" (\neq Buildings Decree 2015) ("Decree of 8 September 2014, amending the Bouwbesluit 2012 to a stricter energy performance coefficient and stricter thermal insulation requirements and amending the "Besluit huurprijzen woonruimte (\neq Rent Decree)", Staatsblad (\neq Bulletin of Acts, Laws and Decrees of the Kingdom of the Netherlands), a minimum R_c value of $4.50 \text{ m}^2\text{K/W}$ is required. Although it is conceivable to modify the cassettes or sections, for example by making them wider, this will lead to undesirably high costs. Finally, using the generally known method it is not possible to renovate buildings in which the cassettes are already present such that the insulation value will meet the occupants' requirements, for example by having said insulation values comply with the aforesaid insulation standards.

[0004] Accordingly it is an object of the present invention to provide a simple and inexpensive method for cladding or covering buildings, in particular for the purpose of achieving a higher insulation value which preferably complies with the 2015 insulation standards, in particular the Bouwbesluit 2015.

[0005] In order to achieve that object, the present invention provides a method for cladding or covering a building at least in part. The building comprises a support on which a multitude of

elongate cassettes are mounted at least partially above each other and parallel to each other. The multitude of cassettes forms at least one elongate box-shaped section, which is open in a direction away from the building.

[0006] The method according to the present invention comprises the step of installing an insulation layer of an insulating material in the section, so that the insulation layer will extend in the direction away from the building beyond the section. Preferably, the insulation layer covers the section on the side remote from the building. The method further comprises the step of mounting at least one spacer on the section, as well as the step of installing a cladding element against the insulation layer, spaced from the section, by means of the spacer for cladding the insulation layer at least in part.

[0007] According to the present invention, the spacer has a substantially L-shaped cross-section and comprises an elongate spacing element and an engaging element. The engaging element comprises an engaging surface for a fastener, which engaging surface extends at an angle, preferably a right angle, to the spacing element. The spacing element and the engaging element substantially form the legs of the L-shaped spacer. The spacer is fixed to the section prior to the step of installing the insulation layer, in such a manner that the spacing element will extend substantially perpendicular to the longitudinal direction of the section, in the direction away from the building, once the spacer is mounted. When mounting a multitude of spacers it is furthermore possible to compensate for any variations in the cassettes and/or the support in a simple manner during the step of installing a multitude of cladding elements, for example by aligning the engaging surfaces of the spacers before fixing them in place. In this way it is possible to compensate for a curvature or a thickening in a cassette or the support.

[0008] In the method according to the present invention, the step of installing a cladding element by means of the spacer for the purpose of at least partially cladding the insulation layer at a position spaced from the section further comprises the step of fixing the cladding element to the engaging surface of the engaging element by means of the fastener. In this step, the insulation layer extends substantially up to the engaging surface, thus forming at least a layer between the engaging surface and the section. The engaging surface will thus remain easily detectable upon installation of the cladding element.

[0009] Using the spacing element, sufficient rigidity is obtained for fixing the cladding element at the desired distance from the section, so that the insulation layer will be sufficiently thick to comply with the aforesaid insulation standards. A drastic modification of the cassette or the section is not required in that case, so that the method according to the present invention is relatively low-cost.

[0010] The present invention is based on the idea that, using a spacing element, the engaging surface for fixing a cladding element thereto can be spaced sufficiently far from the cassette to obtain a sufficiently thick insulation layer having the required insulation value. The object of the present invention is thus achieved.

[0011] It was an insight of the inventor that L-shaped spacers are useful within the method of the present invention. When the L-shaped spacer is mounted on the cassette with the engaging element extending towards the ground, the spacer leaves additional room to easily install the insulation by simply inserting the insulation by tipping it against the upper U portion of the cassette and pushing the yet extending portion of the insulation inside the cassette. Thus, using this type of spacer increases the cladding process efficiency of the method while the spacer is mounted on the cassette by making the process easier and less time consuming.

[0012] It is noted that EP0896106-A2 discloses a T-shaped spacer profile comprising a vertically extending head portion to which the outside sheeting elements are fixed. The head portion in the document extends in two directions from the base of the spacer. This spacer does not enable for easy implementation of the insulation material into the cassette as described in the previous paragraph, because at least one extending part of the head portion obstructs insulation material when one tries to place it in the cassette. During the cladding process it is thus not efficient to have the spacer of the prior art in place before the insulation is placed. Especially when the insulation comprises a stiffer material. Moreover, the L-shaped spacer of the invention has the benefit that a relatively smaller surface can be used while maintaining functionality. This results in higher insulation value potential due to lower conductivity values.

[0013] In an embodiment the L-shaped spacer is mounted on the cassette, whereby the engaging element representing one leg of the "L" is extending towards the ground. An advantage of this embodiment is that after the spacers are mounted on the cassette, it is possible to easily tip the insulation material against the upper U portion of the cassette and simply push the lower yet extending portion of the insulation material into the lower U portion of the cassette. This embodiment thus provides for easy placement of the insulation material. Moreover, the specific orientation of engaging elements in this embodiment may aid in prevention of the upper portion of the insulation material to slide out of the cassettes because the engaging element of the spacer mounted on the upper U portion of the cassette prevents this movement.

[0014] In an embodiment an omega profile is fastened to one or more engaging surface(s) after step (d) is performed. Such an Omega profile is known per se to those skilled in the art. An advantage of this type of embodiment is that the omega profile provides for a much larger surface to use as a fastening surface, and enables the cladding to be connected at any desired and/or selected height at the Omega profile, and not only to the discrete height points provided by the spacers.

[0015] The step of installing the cladding element is carried out after the step of installing the insulation layer. In a preferred embodiment, the cladding element is fixed to the engaging element of the spacer after the spacer has been mounted on the section. The cladding element can be a cladding sheet or the like, or can be a combination of beams or profiles, either horizontal or vertical, on which the cladding sheets are further attached. Preferably, the step of mounting the spacer on the section is carried out prior to the step of installing the

insulation layer. This enables a user to position the spacer on the section during the step of mounting the spacer on the section. In contrast to the generally known method, the spacer can be mounted on the section without any interference from the insulation layer. If a multitude of spacer is used, the user can thus align said spacers with each other, for example by aligning the engaging surfaces of several spacers with each other. In this way said engaging surfaces define an imaginary flat (i.e. free from curvatures, local recesses or elevations) cladding surface or a line. Subsequently, an elongate or plate-shaped cladding element can be fixed to several engaging surfaces in a simple manner without any warping of the cladding element.

[0016] In an advantageous embodiment, the spacer comprises an insulation element configured to reduce the transfer of heat between the inside and the outside of the building via the spacer. Preferably, a single spacer or a multitude of spacers connect(s) the cladding element or the cladding elements to the one or more sections. In use, the spacer forms a thermal bridge between the inside and the outside of the building, so that heat can escape from the building and/or enter the building. The insulation element reduces the thermal bridge effect, so that the insulation value of the composite cladding will remain sufficiently high in accordance with the Bouwbesluit 2015.

[0017] In a simple embodiment, the width and the height of the spacing element are relatively small in comparison with its length, so that the cross-sectional area of the spacing element of the spacer is relatively small. Due to this elongate and narrow configuration of the spacing element, the thermal resistance of the spacing element is sufficiently high to reduce the transfer of heat through the spacing element in accordance with the aforesaid Bouwbesluit. The insulation layer is hardly interrupted by the spacer, so that the insulating effect of the insulation layer will remain optimal. Preferably, at least part of the elongate spacing element of the spacer is configured to have a relatively small cross-sectional area. The transfer of heat through the insulation layer via the spacer will be minimal in that case.

[0018] In one embodiment, the insulation element is realised by forming the spacing element and/or the engaging element of a thermally insulating material, for example stainless steel, plastic, aluminium, SZ (Sendzimir Zinc plated steel) and/or a composite.

[0019] In one embodiment, the insulation element is configured as a thermal interruption in the spacer. Such a thermal interruption can be realised in a simple manner, for example by locally reducing the cross-sectional area of the spacing element. This interruption may be configured as, for example, an opening, a multitude of openings, a constriction, or a connecting portion of an insulating material. The "passage" created by such an opening or constriction in the spacer preferably extends substantially perpendicular to the longitudinal direction of the spacing element. In this way a simple and inexpensive-to-produce spacer having a relatively high thermal resistance is obtained.

[0020] According to the invention, the section comprises at least one section leg extending away from the building. During the step of mounting the spacer on the section, the spacer is fixed to said section leg by means of a further fastener, such as an adhesive, a screw or a bolt.

Because the user, carrying out of the step of mounting the spacer, will fix the spacer to the section prior to the step of installing the insulation layer, the available view and freedom of movement will enable him or her to quickly fix the spacer to the section leg. Preferably, the spacer can be positioned on the section in that case. The spacer can thus be aligned in the direction away from the building. Preferably, a user carrying out the step of mounting the spacer on the section can position said spacer on the section for positioning the engaging surface of the spacer a predetermined distance from the support.

[0021] In one embodiment, the engaging element of the spacer extends in the direction away from the building substantially beyond the insulation layer during the step of installing a cladding element against the insulation layer, spaced from the section, by means of the spacer, so that the engaging surface will be visible to a user upon installation of the cladding element. During this step, the engaging surface is preferably visible to a user to such an extent that a simple and quick fixation of the cladding element thereto can be realised. In particular, the spacing between the support and the engaging surface at least substantially corresponds to or is at least equal to the thickness of the insulation layer. The rigidity of the spacer makes it possible to increase said thickness until the insulation layer, and thus the cladding, has the required insulation value.

[0022] The engaging element can have a front face wider than the elongate spacing element, thus providing enhanced visibility and ease for fastening the cladding thereto.

[0023] This disclosure further relates to a method for renovating buildings, using a method according to the present invention as described in the foregoing. An insulation layer is already present in the section so as to make it possible to carry out the steps of the method according to the present invention. This insulation is not thick enough, however, to comply with an occupant's current needs and/or the current rules. Using the method with the spacer according to the present invention, the outside walls of such buildings can be sufficiently insulated to obtain an R_c value of at least $3.5 \text{ m}^2\text{K/W}$, preferably at least $4 \text{ m}^2\text{K/W}$. Using this renovation method, it is even possible to realise a minimum R_c value of $4.5 \text{ m}^2\text{K/W}$ in a building to be renovated, if an occupant should wish so. The insulation value of the building will thus be in accordance with the Bouwbesluit 2015 after renovation. This renovation method is furthermore inexpensive, because the cassettes present in the building can be reused without any drastic modifications being required. Preferably, this renovation method comprises the step of removing from the section the insufficiently insulating insulation layer that is already present prior to carrying the other steps of the method according to the present invention.

[0024] The invention further relates to an assembly for forming at least part of a cladding or covering of a building. This assembly according to the present invention comprises a multitude of elongate cassettes, which are mounted at least partially above each other and parallel to each other on a support of the building. The multitude of cassettes forms at least one elongate box-shaped section. This section is open in a direction away from the building, so that the section is configured for installing an insulation layer of an insulating material at least in part therein. The assembly also comprises at least one spacer, which is mounted on the section.

The spacer is configured for fixing a cladding element thereto, spaced from the section.

[0025] According to the present invention, the spacer comprises an elongate spacing element and an engaging element. The engaging element comprises an engaging surface for a fastener, which engaging surface extends at an angle, preferably a right angle, to the spacing element. The engaging surface of the engaging element is configured for fixing the cladding element thereto by means of the fastener. The spacer according to the present invention provides sufficient rigidity for configuring the insulation layer with a thickness that corresponds to the minimum insulation value for the cladding in accordance with the Bouwbesluit 2015. In addition to that, the spacer according to the present invention can be used substantially without modifying the generally known cassettes, so that the assembly according to the present invention can be produced at low cost. Finally, a user has the possibility to align the various engaging surfaces of the spacers relative to each other prior to or during a step of mounting a multitude of spacers on the section. The user can thus compensate for unevennesses in the support and/or the cassettes, so that a flat cladding can be installed in a simple manner.

[0026] The spacer is mounted on a section leg of the section that extends away from the building, for example by means of a further fastener. The spacing element of the spacer can thus be fixed to the section leg in a simple and quick manner, using a bolt or a screw. A user will in that case have a possibility to position the spacing element before fixing it in place.

[0027] In one embodiment, the insulation layer is present between the support and the engaging surface. The thickness of the insulation layer, measured in the direction away from the building, will in that case be such that the insulation layer (and thus the final cladding) will comply with the aforesaid insulation standards in accordance with the Bouwbesluit 2015. Preferably, the insulating material of the insulation layer is a mineral wool, more preferably rock wool or glass wool, which can be installed in the section in a simple manner. For instance, the total insulation thickness can be at least 200 mm.

[0028] In one embodiment, the cladding element is fixed to the engaging surface of the engaging element by means of a fastener. In this way a cladding or covering of a building providing a high-value insulation effect is obtained.

[0029] In an advantageous embodiment, the spacer comprises an insulation element configured to reduce the transfer of heat between the inside and the outside of the building via the spacer. This insulating effect is preferably realised essentially in that the cross-sectional area of the spacing element is significantly smaller than the sectional area of that part of the section, for example a section leg, on which the spacing element is mounted. In use, heat is transported from the inside of the building mainly via the section of the cassette, and subsequently to the outside via the spacer. The small cross-sectional area of the spacing element reduces this heat loss in that this spacer has a relatively high thermal resistance in comparison with the section. In one embodiment, the insulation element is realised by forming the spacing element and/or the engaging element of a thermally insulating material, for example stainless steel, plastic, aluminium, SZ and/or a composite, so that the thermal

resistance and thus the insulating effect of the spacer are increased.

[0030] In one embodiment, the insulation element is configured as a thermal interruption in the spacer, preferably in the form of an opening, a multitude of openings, a constriction, or a connecting portion of an insulating material. Because material is locally removed from the spacing element and/or the engaging element, the thermal resistance of the spacer is increased. The openings, recesses or constrictions may be provided in such a manner that the rigidity of the spacer is substantially retained. In this way a simple and inexpensive-to-produce spacer having a relatively high thermal resistance is obtained.

[0031] In one embodiment, the spacing element comprises an elongate plate element and/or the engaging element comprises a further plate element. Such a spacer can be produced in a simple manner. In addition to that, the openings, constrictions and/or recesses can be easily formed in the plate element as thermal interruptions. Other embodiments of the spacer, for example in the form of a tube, a cylinder or a bar, are also conceivable within the scope of the appended claims.

[0032] The invention will now be explained in more detail with reference to the appended figures. Like parts are indicated by the same numerals as in figures 1 and 2, indicated by 100, 200, 300, 400, 500, 600, 700 or 800 for the respective embodiments.

Figure 1 is a sectional view of an assembly according to the present invention;

Figure 2 is a perspective view of a detail of an assembly according to the present invention;

Figures 3a-h are perspective views of various embodiments of a spacer according to the present invention;

Figure 4a-e present a series of specific embodiments of the spacer wherein 4a provides an exploded view of the spacer, 4b a top view of the spacer and 4b-e present cross sectional views comprising variations in the cross section of the spacer; and

Figure 5 shows a schematic perspective view of an assembly according to the present invention.

[0033] Figure 1 shows a sectional view of an assembly 1 according to the present invention. Using the method according to the present invention, a building is at least partially clad or covered. The building comprises a support 20, on which a multitude of elongate cassettes (two cassettes 60, 60' disposed one above the other being partially shown in figure 1) are mounted at least partially above each other and parallel to each other. In figure 1 the lower side of the higher cassette 60 and the upper side of the cassette 60' disposed thereunder are shown. The multitude of cassettes forms at least one elongate box-shaped section 30, which is open in a direction P away from the building. Figure 1 shows the generally known embodiment of the multitude of cassettes. In the embodiment shown in figure 1, the upper cassette 60 of the two

cassettes 60, 60' forms the section 30 and the lower cassette 60' forms the section 30'. According to the present invention it is also conceivable that several cassettes together form one box-shaped section, for example when L-shaped cassettes are used.

[0034] The method further comprises the steps of installing an insulating layer 50 of an insulating material in the section 30, so that the insulation layer will extend in the direction P away from the building beyond the section 30. The method further comprises the step of fixing at least one spacer 10 to the section 30 as well as the step of installing a cladding element 40 against the insulation layer 50, spaced from the section 30, by means of the spacer 10 for cladding the insulation layer 50 at least in part. According to the present invention, the spacer 10 comprises an elongate spacing element 11 and an engaging element 12, which engaging elements 12 comprises an engaging surface (indicated at 13 in figure 2) for a fastener 19, which extends at an angle α , preferably a right angle, to the spacing element 11. The method according to the present invention further comprises the step of fixing the spacer 10 to the section 30 prior to the step of installing the insulation layer 50, in such a manner that the spacing element 11 will extend substantially perpendicular to the longitudinal direction of the section 30, in the direction P away from the building, once the spacer is mounted. During the step of installing the cladding element 40 by means of the fastener 19, the cladding element 40 is fixed to the engaging surface 13 of the engaging element.

[0035] The building preferably has a relatively large storage volume typical of a shed or industrial or commercial use. Such a building is usually constructed from a framework, such as a structure of steel beams. Such a framework forms the support 20 for the cassettes 60, 60'. In figure 1 the support 20 is shown as a vertically extending beam 20, to which the cassette 60 is fixed by means of a fastener 35, for example a screw or a bolt. In a similar manner, the cassette 60' is fixed to the support by means of the screw 35'. In practice, the cassette 60, 60' is fixed to two or more spaced-apart vertical beams 20. In practice, a multitude of elongate cassettes 60, 60' are mounted on the support 20 at least partially above each other and parallel to each other. The present invention can be used with buildings on which the cassettes 60, 60' are to be placed yet, as well as in the renovation of buildings in which the cassettes 60, 60' are already present.

[0036] The cassette 60 that is shown in figure 1 forms at least one elongate box-shaped section 30, which is open in a direction P away from the building. Likewise, the cassette 60' forms the section 30'. According to the invention it is conceivable for several cassettes together to form one box-shaped section. The visible part of the cassette 60 in figure 1 is an L-section, but the skilled person will appreciate that the cassette 60 may also be configured as a U-section, for example. The same goes for the cassette 60'. The section 30 in figure 1 comprises a first section leg 31, which extends in the vertical direction H of the building, and a second section leg 32, which extends in the direction P away from the building. The section 30' is configured correspondingly. The generally known cassettes 60, 60' comprise sections 30, 30' provided with a screw fixing element 33, 33' at the end remote from the building of the second section leg 32, 32'. With the generally known cassettes 60, 60', a section leg part 34, 34' is provided on the screw fixing element 33, 33', at an angle thereto. According to the present

invention, the elements 33, 33', 34, 34' are not necessary, but they may be used for realising a quick and simple alignment of the cassettes 60, 60' when of the cassettes 60, 60' are being installed on the support 20. For the rest, reference will generally be made to the cassette 60, also in those cases where in fact the assembly of the upper and the lower cassette 60, 60' is meant.

[0037] In the method according to the present invention, the cassette 60 may already be present on the support 20 or it can be installed thereon. The installed cassette 60 in figure 1 forms a section 30, to which the spacer 10 is fixed during the step of mounting at least one spacer 10. In figure 1, the spacer 10 is connected to the second section leg 32 of the section 30 during the step of fixing the spacer 10 to the section 30 by using a further fastener 18, for example a screw, a bolt, a layer of adhesive or other known fastening means. Said further fastener 18 may also be connected to a second section 30' of a lower cassette 60'. The parts 32, 33, 34 of the upper section 30 to that end overlap with the parts 32', 33', 34' of the lower section 30'. The spacer 10 comprises an elongate spacing element 11 and an engaging element 12. The spacer 10 is fixed to the section 30 during the step of mounting the spacer 10, prior to the step of installing the insulation layer 50, such that once the spacer is mounted, the spacing element 11 will extend substantially perpendicular to the longitudinal direction (indicated at L in figure 2) of the section 30 in the direction P away from the building. The engaging element 12 comprises an engaging surface (indicated at 13 in figure 2) for a fastener 19. This engaging surface 13 extends at an angle α , a right angle in figure 1, to the spacing element 11. Other angles α are also conceivable.

[0038] When carrying out the step of fixing the spacer 10 to the section 30, a user has a possibility to position the engaging surface 13 a desired distance from the support 20 when fixing the spacing element 11 to the second section leg 32 of the section 30. The user can do so, for example, by aligning the engaging surfaces 13 of various spacers 10. The user can thus compensate for unevennesses in the support 20 and/or the cassettes 60, 60', for example when the beams of the supports 20 are not disposed in one line. The user can do so during the step of mounting the spacer 10, for example by providing the fastener 18 at a desired position in the spacing element 11 and/or the second section leg 32. Alternatively, for example when a bolt or a screw 18 is used, a slotted opening may be provided in the spacing element 11. The screw or bolt 18 will in that case be capable of translational movement within such an elongate opening before being fixed in place.

[0039] Subsequently, i.e. after the step of fixing the spacer 10 to the section 30, the step of placing an insulation layer 50 of an insulating material in the section 30 is carried out, so that the insulation layer 50 will extend in the direction P away from the building beyond section 30. In figure 1 the insulation layer 50 covers the section 30, so that part of the insulation layer 50 is located between the section 30 and the engaging surface 13. The engaging surface 13 remains visible to the user, which is advantageous when carrying out the next step of installing a cladding element 40.

[0040] Subsequent to the step of installing the insulation layer 50, the step of placing a

cladding element 40 against the insulation layer, spaced from the section 30, by means of the spacer 10 is carried out for cladding the insulation layer 50 at least in part. During the step of installing the cladding element 40, use is made of the fastener 19 for fixing the cladding element 40 to the engaging surface 13 of the engaging element 12. The cladding element 40 can preferably accommodate the engaging element 12 at least in part. Preferably, each cladding element 40 is fixed to a multitude of spacers 10 arranged above each other so as to obtain a stable fixation. After the steps of installing the cladding elements 40, the cladding elements 40, possibly in combination with additional cladding means, form a complete covering of the insulation layer 50 on the side remote from the building.

[0041] As also shown in figure 1, the cladding element 40 is spaced from the section 30 by a distance d in the direction P away from the building. The present invention makes it possible to increase the distance d in comparison with the prior art, so that a thicker insulation layer 50 can be used. This leads to an increased insulation value of the cladding. By way of illustration, using the generally known method with the spacer screw, the distance d can be 60 mm at most, whilst the spacer 10 according to the present invention makes it possible to use a distance d of more than 60 mm.

[0042] In figure 1, the section comprises at least one section leg 32 extending in the direction P . The spacer 10 is fixed thereto by means of a further fastener 18, being the bolt 18. In figure 1, the further fastener 18 connects the spacing element 11 also to the section leg 32' of the section 30' disposed below the section 30. The spacer 10 can preferably be freely positioned on the section leg 32. The spacer 10 can thus be aligned in the direction P . In addition to that, the engaging surface 13 of the spacer 10 can be positioned at a predetermined distance from the support 20 when carrying out the step of fixing the spacer 10 to the section 30. The distance between the section legs 31 and 12 determines the thickness of the insulation layer 50, and this thickness can thus be set. In addition to that, the engaging surfaces 13 of several spacers 10 can be aligned with each other, for example in line or in one plane.

[0043] During the step of installing the cladding element 40, the engaging element 12 preferably extends in the direction P beyond the insulation layer 50. The engaging surface 13 is in that case visible to a user so as to make a simple and quick fixation of the cladding element 40 possible.

[0044] Figure 2 shows in perspective view a detail of an assembly 1 according to the present invention. The assembly 1 is similar to the assembly 1 in figure 1. Figure 2 in particular shows the substantially plate-shaped configurations of the spacer 1 and the shape of the Ω -section of the cladding element 40. In figure 2, the cladding element 40 is cut off, but it is also conceivable for the cladding element 40 to continue in the vertical direction H . In addition to that, in contrast to figure 1 only one cassette 60 of the multitude of cassettes is shown in figure 2.

[0045] As figure 2 shows, the spacer 10 comprises an insulation element 14. This insulation element 14 increases the thermal resistance of the spacer 10, so that the transfer of heat

between the inside and the outside of the building via the spacer 10 is decreased. When the inside of a building is heated, heat is transported via the section leg 32 in the direction P into the insulation layer 50 (not shown), resulting in a further decreased insulating effect of the assembly 1. In the assembly 1 according to the present invention, further transport of heat from the section leg 32 in the direction P is considerably reduced by the spacer 10. The cross-sectional area of the spacing element 11 is considerably smaller than the sectional area of the section leg 32, so that the thermal resistance of the spacer 10 is relatively high. Loss of heat via the spacer 10 is thus reduced. Preferably, the length x of the spacing element ranges between 100 and 400 mm and the width y ranges between 10 and 100 mm. In figure 2, the length x of the spacing element 11 is about 220 mm, whilst the width y is about 40 mm. The width of the engaging surface 13 is also about 40 mm. The distance z between the spacing element 11 and the cladding element 40 is about 30 mm. It stands to reason that other values can also be used within the scope of the present invention.

[0046] The insulation element 14 may be formed by forming the spacing element 11 and/or the engaging element 12 of a thermally insulating material, for example stainless steel, plastic, aluminium, SZ and/or a composite. In this way a high thermal resistance of the spacer 10 and thus a low heat loss is guaranteed. Furthermore, part of the spacer 10, for example the hatched zone shown in figure 2, may be made of a thermally insulating material.

[0047] In addition to that, the insulation element 14 may be configured as a thermal interruption 14 in the spacer 10. This interruption 14 preferably reduces the cross-sectional area of the spacer 10 locally, without essentially affecting the rigidity of the spacer 10. The interruption 14 is for example made up of one or more openings, one or more constrictions, one or more recesses and/or one or more connecting parts made of an insulating material. In figure 2, the thermal interruption 14 is configured as a circular opening 14, which locally increases the thermal resistance of the spacing element 11. Other embodiments of spacers and thermal interruptions according to the present invention are shown in figures 3b-h.

[0048] In figure 2, the spacer 10 comprises an elongate plate element 11 as the spacing element 11 and a further plate element 12 as the engaging element 12. In this way an easy-to-produce spacer 10 is obtained, in which spacer the thermal interruption 14 can be formed using drilling and/or cutting means, for example.

[0049] Figure 3a shows in perspective view an embodiment of a spacer 110 according to the present invention. The spacer 110 comprises a spacing element 111 in the form of an elongate plate element 111. Connected to one end of the spacing element 111 is the engaging element 112 with the engaging surface 113. The spacing element 111 and/or the engaging element 112 are preferably made of stainless steel, plastic, aluminium, SZ (Sendzimir Zinc plated steel) or a composite. Quite preferably, the spacing element 111 and/or the engaging element 112 are formed of a material having a low thermal conductivity so as to reduce the transfer of heat via the spacer 110. In figure 3a, the spacing element 111 and/or the engaging element 112 are furthermore directly connected at a right angle α . According to the present invention it is also conceivable, however, for these parts 111, 112 to be connected at an angle α different from a

right angle, and possibly via a connecting element.

[0050] Figure 3b shows in perspective view an embodiment of a spacer 210 according to the present invention. The spacer 210 comprises a spacing element 211 in the form of an elongate plate element 211. This spacer 210 is configured substantially similar to the spacer 110 of figure 3a, with this difference that a thermal interruption to a known 14 in the form of an opening 214 is provided in the spacing element 211. The through opening to a known 14 extends to either side of the spacing element 211 of the thermal interruption 214 is sufficiently large for reducing the transfer of heat via the space 210 without affecting the rigidity of the spacer 210 that is required for the construction of the assembly 1. According to the present invention it is also conceivable that a multitude of openings 214 are provided in the spacing element 211 and/or the engaging element 212 for the purpose of increasing the thermal resistance of the spacer 210.

[0051] Figure 3c shows in perspective view an embodiment of a spacer 310 according to the present invention. This spacer 310 corresponds to the spacer 110 shown in figure 3a, with this difference that the spacing element 311 comprises a first element part 311a which is connected to the engaging element 312 via a second element part 311b. The first element part 311a has a smaller cross-section than the second element part 311b. This constriction thus forms a thermal interruption for reducing the transfer of heat via the spacer 310.

[0052] Figure 3d shows in perspective view an embodiment of a spacer 410 according to the present invention. In this embodiment, the spacing element 411 is connected to a connecting element 412a which is provided at a right angle α to the engaging part 412b of the engaging element 412. In this embodiment, the various elements 411, 412 can simply be made of different materials. Preferably, said elements 411, 412 are connected by a connecting means, such as a screw, a bolt, or an adhesive.

[0053] In each of embodiments shown in figures b-d, the configuration of the spacer has been adapted in comparison with that of the spacer 110 shown in figure 3a so as to increase the insulation value of the spacer. In the embodiments shown in figures 3e-3h to be described below, the spacer 10 has been modified in comparison with figure 3a for the purpose of making the spacer more rigid. To obtain a solid fixation of the cladding element 40, deformation of the engaging surface, and thus of the engaging element, must be prevented. It is in particular important to exclude any variation in the angle α between the engaging surface and the spacing element. The spacers shown in figures 3e-3h are for that purpose provided with stiffening means so as to prevent deformation of the spacing element and the engaging surface as well as a decrease or increase of the angle α upon installation of the cladding element 40.

[0054] Figure 3e shows in perspective view an embodiment of a spacer 510 according to the present invention, which essentially corresponds to the embodiment 110 shown in figure 3a. In figure 3e, a multitude of recesses 514 are provided in the spacer 510. The recesses 514, which function as stiffening means in order to prevent at least a decrease or an increase of the

angle α , extend from the spacing element 511 into the engaging surface 513 of the engaging element 512.

[0055] Figure 3f shows in perspective view an embodiment of a spacer 610 according to the present invention, which essentially corresponds to the embodiment 110 shown in figure 3a. The engaging element 612 is in this case further provided with plate-shaped lateral parts 615, which extend at an angle to the engaging surface 613. In use, the lateral parts are located at the bottom side of the spacing element 611 for stiffening the spacer 610 so as to prevent deflection of the spacing element 611.

[0056] Figure 3g shows in perspective view an embodiment of a spacer 710 according to the present invention, which essentially corresponds to the embodiment 410 shown in figure 3d. The connecting part 712a in figure 3g is capable of accommodating one end of the spacing element 711.

[0057] Figure 3h shows in perspective view an embodiment of a spacer 810 according to the present invention, which essentially corresponds to the embodiment 110 shown in figure 3a. The engaging element 812 shown in figure 3h has been formed by folding part of the plate-shaped engaging element 812 back onto the spacing element 811. In this way stiffening means are formed which prevent deformation of the engaging element 12 and the engaging surface 13 and which also prevent a decrease or increase of the angle α .

[0058] Figure 4a depicts a particularly useful embodiment of the spacer 910. The spacer comprises an elongate spacing element 911 and an engaging element 912. In reference to the defined coordinate system of figure 2, the spacer 910 is defined having a corresponding x,y,z-axis. The elongate spacing element 911 comprises an elongate spacing surface with, in use, a length along the x-axis and a width, in use, along the y-axis in plane (x,y), and the engaging element comprises an engaging surface comprising a length, in use, along the z-axis and width, in use, along the y-axis in plane (z,y). At least a portion of the engaging surface 912 extends at an angle, preferably a right angle, substantially 90 degrees, to the spacing element 911. As derivable from figure 4a, the elongate spacing surface comprises a through hole 914 adapted to reduce conductive heat transfer through the spacing element 911. The engaging element 911 may be provided with further openings, such as through holes (not shown) for connection to the "Ü" shaped legs of the cassette.

[0059] As shown in Fig. 4a, the elongate spacing element 911 and the engaging element 912 are not formed integrally, but are formed from two different parts. In particular this allows the spacer (in particular the spacing element and the engaging element) to be manufactured from two different materials. In an embodiment, the engaging element 912 is made from sendzimir galvanised steel, because this material is relatively easy to handle and commonly used, and allows the cladding to be easily connected to the engaging surface. However, this material provides for relatively high thermal conductivity. In order to reduce thermal conductivity, the dimensions of the elongate spacing surface 911 are made to be relatively small, while the desired length of the elongate spacing surface 911 is maintained. The spacing element 911 is

particularly made from stainless steel. This material is relatively sturdy and has a low thermal conductivity. Other materials with the above described properties are conceivable as well.

[0060] In particular, the maximum width of the elongate spacing surface is preferably 65 mm or less and the minimum width of the engaging surface is no more than 130 mm. These considerations result in a substantially "T" shaped spacer 910 when viewed from the top. The spacer has, however, an L-shaped cross section, as is apparent from Fig. 4a.

[0061] Preferably, both the elongate spacing element and the engaging element are no thicker than 2 mm. Using as little material as possible while still maintaining constructional demands, reduces thermal conductivity of the material used in the spacer 910.

[0062] Now referring to figure 4b. In this particular embodiment the substantially "T" shaped spacer 1010 comprising the elongate spacing element 1011 and the engaging element 1012 are formed out of an integrated part. Through hole 1014 in the elongate spacing element 1011 is placed near the engaging element 1012.

[0063] Figure 4c shows the cross section of an embodiment of the L-shaped spacer 1110 comprising elongate spacing element 1111 and engaging element 1112. Here the engaging element 1112 is attached to elongate spacing element 1111 via right-angled portion 1112a.

[0064] Figure 4d shows the cross section of a particular embodiment of the L-shaped spacer 1210 wherein a portion of the elongate spacing element 1211 comprises a "Z" shaped bend 1250 adjusted to engage with a bend or irregularities of a leg of the "U" shaped cassette. An advantage of this embodiment is that a better fit is made with the cassette.

[0065] Figure 4e shows the cross section of a particular yet special embodiment of spacer 1310. Here elongate spacing element 1311 comprises a "V" shaped bend 1350. This embodiment fits great with cassettes comprising a leg portion having a similar shape as the bend 1350, and allows for a correct positioning of the L-shaped spacer.

[0066] The cladding element can be in the form of cladding sheets directly fixed to the spacers as shown in Figure 1, or cladding sheets can be fixed to a series of beams or profiles which are fixed to the spacers as shown in Figure 5. Here, the structure of the cassettes 1460 with insulation material 1414, the spacer element 1410 having the elongate spacing element 1411 and the engaging element 1412 having a larger width compared to the spacing element 1411 can be seen. To the engaging element 1412, an omega profile 1450 is attached. A cladding element 1440 is attached to this omega profile 1450.

[0067] In the foregoing, the invention has been described on the basis of a few exemplary embodiments. The skilled person will appreciate that many modifications and alternatives are possible within the scope of the appended claims. The invention is not limited to these exemplary embodiments, however. The protection sought, i.e. the invention, is determined by the appended claims.

REFERENCES CITED IN THE DESCRIPTION

This list of references cited by the applicant is for the reader's convenience only. It does not form part of the European patent document. Even though great care has been taken in compiling the references, errors or omissions cannot be excluded and the EPO disclaims all liability in this regard.

Patent documents cited in the description

- EP0896106A2 [0012]

PATENTKRAV

1. Fremgangsmåde til mindst delvis beklædning eller afdækning af en
5 bygning, hvilken fremgangsmåde omfatter en bærer (20), hvorpå en flerhed af
langstrakte kassetter (60, 60') er monteret mindst delvis oven over hinanden og
parallelt med hinanden, hvilken flerhed af kassetter (60, 60') danner mindst et
langstrakt kasseformet afsnit (30, 30'), der er åbent i en retning væk fra
bygningen, hvor afsnittet (30, 30') omfatter mindst ét afsnitsben (32, 32'), som
10 strækker sig væk fra bygningen, hvilken fremgangsmåde omfatter følgende trin:
- a) anbringelse af et isoleringslag (50) af et isoleringsmateriale i afsnittet (30,
30'), således at isoleringslaget (50) strækker sig i retningen væk fra bygningen
ud over afsnittet (30, 30');
- 15 b) montering af mindst én afstandsholder (10, 110, 210, 310, 410, 510, 610,
710, 810, 910) på afsnittet (30, 30');
- c) anbringelse af et beklædningselement (40) mod isoleringslaget (50), med
afstand fra afsnittet (30, 30'), ved hjælp af afstandsholderen (10, 110, 210, 310,
410, 510, 610, 710, 810, 910) til mindst delvis beklædning af isoleringslaget (50);
20
- kendetegnet ved, at** afstandsholderen (10, 110, 210, 310, 410, 510, 610,
710, 810, 910) har et i det væsentlige L-formet tværsnit og omfatter et langstrakt
afstandselement (11, 111, 211, 311, 411, 511, 611, 711, 811, 911) og et
indgrebselement (12, 112, 212, 312, 412, 512, 612, 712, 812, 912), hvor
25 indgrebselementet (12, 112, 212, 312, 412, 512, 612, 712, 812, 912) omfatter en
indgrebsflade (13, 113, 213, 313, 413, 513, 613, 713, 813, 913) til et
fastgørelseselement (19), hvilken indgrebsflade (13, 113, 213, 313, 413, 513, 613,
713, 813, 913) strækker sig i en vinkel, fortrinsvis en højre vinkel, til
afstandselementet (11, 111, 211, 311, 411, 511, 611, 711, 811, 911);
30 ved trinnet med:
- d) fastgørelse af afstandsholderen (10, 110, 210, 310, 410, 510, 610, 710,
810, 910) til afsnitsbenet (32, 32') på afsnittet (30, 30') ved hjælp af et yderligere
fastgørelseselement (18) inden trin (a) på en sådan måde, at afstandselementet
(11, 111, 211, 311, 411, 511, 611, 711, 811, 911) strækker sig i det væsentlige

vinkelret på afsnittets (30, 30') længderetning i retningen væk fra bygningen, når først afstandsholderen (10, 110, 210, 310, 410, 510, 610, 710, 810, 910) er monteret; og hvor trinnet (c) med anbringelse af beklædningselementet (40) omfatter det trin, at beklædningselementet (40) ved hjælp af fastgørelseselementet (19) fastgøres til indgrebsfladen (13, 113, 213, 313, 413, 513, 613, 713, 813, 913) på indgrebselementet (12, 112, 212, 312, 412, 512, 612, 712, 812, 912).

2. Fremgangsmåde ifølge krav 1, hvor trin (c) udføres efter trin (d).

10 **3.** Fremgangsmåde ifølge et hvilket som helst af de foregående krav, hvor afstandsholderen (10, 210, 910) omfatter et isoleringselement (14, 214, 914), der er konfigureret til at reducere varmeoverførslen mellem bygningens inderside og yderside via afstandsholderen (10), især hvor isoleringselementet (14, 214, 914) opnås ved dannelse af afstandselementet (11, 211, 911) og/eller
15 indgrebselementet (12, 212, 912) ud af et varmeisolerende materiale, f.eks. rustfrit stål, plastmateriale, aluminium, SZ og/eller et kompositmateriale.

4. Fremgangsmåde ifølge krav 3, hvor isoleringselementet (14, 214, 914) er konfigureret som en termisk afbrydelse i afstandsholderen (10, 210, 910),
20 fortrinsvis i form af en åbning, en flerhed af åbninger, en indsnævring eller en forbindelsesdel af et isoleringsmateriale.

5. Fremgangsmåde ifølge et hvilket som helst af de foregående krav, hvor afstandsholderen (10, 110, 210, 310, 410, 510, 610, 710, 810, 910) kan positioneres
25 på afsnittet (30, 30') under trin (d) til positionering af indgrebsfladen (13, 113, 213, 313, 413, 513, 613, 713, 813, 913) på afstandsholderen (10, 110, 210, 310, 410, 510, 610, 710, 810, 910) i en forudbestemt afstand fra bæreren (20).

6. Fremgangsmåde ifølge et hvilket som helst af de foregående krav, hvor
30 indgrebselementet (12, 112, 212, 312, 412, 512, 612, 712, 812, 912) på afstandsholderen (10, 110, 210, 310, 410, 510, 610, 710, 810, 910) strækker sig i retningen væk fra bygningen i det væsentlige ud over isoleringslaget (50) under trin (c), således at indgrebsfladen (13, 113, 213, 313, 413, 513, 613, 713, 813, 913) vil være synlig for en bruger.

7. Fremgangsmåde til renovering af bygninger, hvor der anvendes en fremgangsmåde ifølge et hvilket som helst af de foregående krav, og hvor der forekommer et isoleringslag (50) i afsnittet (30, 30'), inden trinnene (a)-(d) udføres, og især omfattende det trin, at det isoleringslag (50), der allerede forekommer, fjernes fra afsnittet (30, 30') inden udførelse af trinnene (a)-(d).

8. Samling til dannelse af mindst en del af en beklædning eller afdækning af en bygning, hvilken samling omfatter:

10

– en flerhed af langstrakte kassetter (60, 60'), der mindst delvis er monteret oven over hinanden og parallelt med hinanden på en bærer (20) af bygningen, hvor flerheden af kassetter (60, 60') danner mindst ét langstrakt kasseformet afsnit (30, 30'), der er åbent i en retning væk fra bygningen, således at afsnittet (30, 30') er konfigureret til anbringelse af et isoleringslag (50) af et isoleringsmateriale mindst delvis deri;

15

– mindst én afstandsholder (10, 110, 210, 310, 410, 510, 610, 710, 810, 910), der er monteret på afsnittet (30, 30'), og som er konfigureret til fastgørelse af et beklædningselement (40) derpå, med afstand fra afsnittet (30, 30'),

20

kendetegnet ved, at afstandsholderen (10, 110, 210, 310, 410, 510, 610, 710, 810, 910) har et i det væsentlige L-formet tværsnit og omfatter et langstrakt afstandselement (11, 111, 211, 311, 411, 511, 611, 711, 811, 911) og et indgrebselement (12, 112, 212, 312, 412, 512, 612, 712, 812, 912), hvilket indgrebselement (12, 112, 212, 312, 412, 512, 612, 712, 812, 912) omfatter en indgrebsflade (13, 113, 213, 313, 413, 513, 613, 713, 813, 913) til et fastgørelseselement (19), hvor indgrebsfladen (13, 113, 213, 313, 413, 513, 613, 713, 813, 913) strækker sig i en vinkel, fortrinsvis en højre vinkel, til afstandselementet (11, 111, 211, 311, 411, 511, 611, 711, 811, 911), hvor indgrebsfladen (13, 113, 213, 313, 413, 513, 613, 713, 813, 913) på indgrebselementet (12, 112, 212, 312, 412, 512, 612, 712, 812, 912) er konfigureret til fastgørelse af beklædningselementet (40) derpå ved hjælp af fastgørelseselementet (19), og hvor afstandsholderen (10, 110, 210, 310, 410, 510,

25

30

610, 710, 810, 910) ved hjælp af et yderligere fastgørelseselement (18) er monteret på et afsnitsben (32, 32') på afsnittet (30, 30'), der strækker sig væk fra bygningen.

9. Samling ifølge krav 8, hvor afstandsholderen (10, 210, 910) omfatter et isoleringselement (14, 214, 914), der er konfigureret til at reducere varmeoverførslen mellem bygningens inderside og yderside via afstandsholderen (10, 210, 910).

10. Samling ifølge krav 9, hvor isoleringselementet (14, 214, 914) opnås ved dannelse af afstandselementet (11, 211, 911) og/eller indgrebselementet (12, 212, 912) ud af et varmeisolerende materiale, f.eks. rustfrit stål, plastmateriale, aluminium, SZ og/eller et kompositmateriale.

11. Samling ifølge krav 9 eller 10, hvor isoleringselementet (14, 214, 914) er konfigureret som en termisk afbrydelse i afstandsholderen (10, 210, 910), fortrinsvis i form af en åbning, en flerhed af åbninger, en indsnævring eller en forbindelsesdel af et isoleringsmateriale.

12. Samling ifølge et hvilket som helst af kravene 8-11, hvor afstandselementet (11, 111, 211, 311, 411, 511, 611, 711, 811, 911) omfatter et langstrakt pladeelement, og/eller hvor indgrebselementet (12, 112, 212, 312, 412, 512, 612, 712, 812, 912) omfatter et yderligere pladeelement med samme, mindre eller større bredde for det langstrakte pladeelement.

13. Samling ifølge et hvilket som helst af kravene 8-12, hvor isoleringslaget (50) forekommer mellem bæreren (20) og indgrebsfladen (13, 113, 213, 313, 413, 513, 613, 713, 813, 913).

14. Samling ifølge krav 13, hvor beklædningselementet (40) ved hjælp af et fastgørelseselement (19) er fastgjort til indgrebsfladen (13, 113, 213, 313, 413, 513, 613, 713, 813, 913) på indgrebselementet (12, 112, 212, 312, 412, 512, 612, 712, 812, 912), hvorved beklædningselementet (40) kan omfatte en bjælke eller profil, hvorpå der er fastgjort en beklædningsplade.

- 15.** Samling ifølge et hvilket som helst af kravene 8-14, hvor isoleringsmaterialet i isoleringslaget (50) er en mineraluld, fortrinsvis stenuld eller glasuld.
-

DRAWINGS

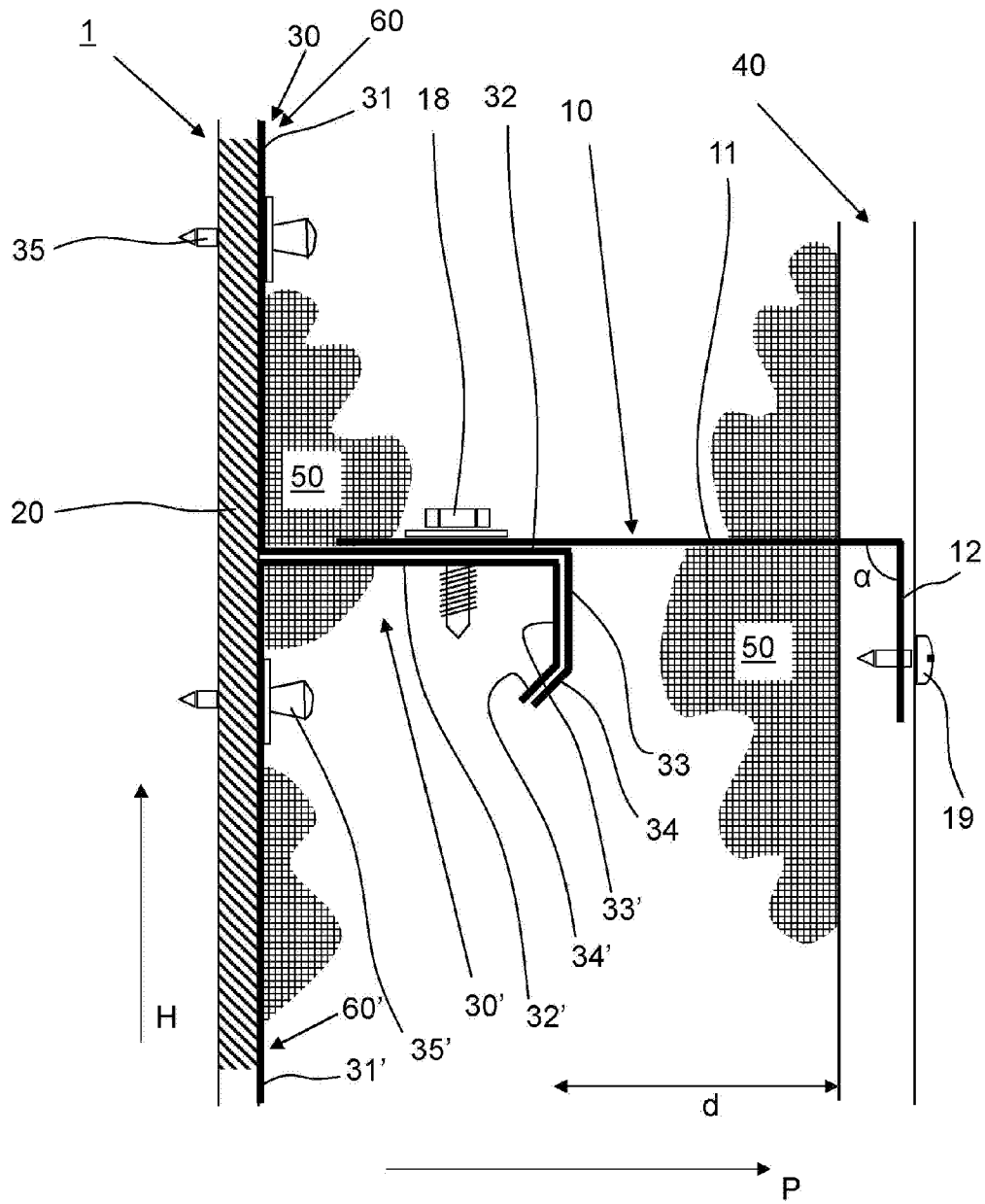

Fig. 1

