

(19) World Intellectual Property
Organization
International Bureau



(43) International Publication Date
13 May 2004 (13.05.2004)

PCT

(10) International Publication Number
WO 2004/039527 A2

(51) International Patent Classification⁷: **B23K 9/235**,
15/00, 20/12, C22F 1/04

(21) International Application Number:
PCT/GB2003/004646

(22) International Filing Date: 28 October 2003 (28.10.2003)

(25) Filing Language: English

(26) Publication Language: English

(30) Priority Data:
0225518.0 1 November 2002 (01.11.2002) GB

(71) Applicant (for all designated States except US): **AIRBUS
UK LIMITED** [GB/GB]; New Filton House, Filton, Bris-
tol BS99 7AR (GB).

(72) Inventors; and

(75) Inventors/Applicants (for US only): **ILYUSHENKO**,

Rostyslav [UA/GB]; Flat 33, 71 Pembroke Road, Bristol
BS8 3DR (GB). **MAZIARZ, Robert, Jan** [GB/GB]; 71
Hill House Road, Downend, Bristol BS16 5RT (GB).
DAVIES, Huw [GB/GB]; 12 Monks Park, Malmesbury,
Wiltshire SN16 9JF (GB).

(74) Agents: **PEARSON, James, Ginn** et al.; Abel & Imray,
20 Red Lion Street, London WC1R 4PQ (GB).

(81) Designated States (national): AE, AG, AL, AM, AT, AU,
AZ, BA, BB, BG, BR, BY, BZ, CA, CH, CN, CO, CR, CU,
CZ, DE, DK, DM, DZ, EC, EE, EG, ES, FI, GB, GD, GE,
GH, GM, HR, HU, ID, IL, IN, IS, JP, KE, KG, KP, KR,
KZ, LC, LK, LR, LS, LT, LU, LV, MA, MD, MG, MK,
MN, MW, MX, MZ, NI, NO, NZ, OM, PG, PH, PL, PT,
RO, RU, SC, SD, SE, SG, SK, SL, SY, TJ, TM, TN, TR,
TT, TZ, UA, UG, US, UZ, VC, VN, YU, ZA, ZM, ZW.

(84) Designated States (regional): ARIPO patent (GH, GM,
KE, LS, MW, MZ, SD, SL, SZ, TZ, UG, ZM, ZW),
Eurasian patent (AM, AZ, BY, KG, KZ, MD, RU, TJ, TM),

[Continued on next page]

(54) Title: WELDING METHOD

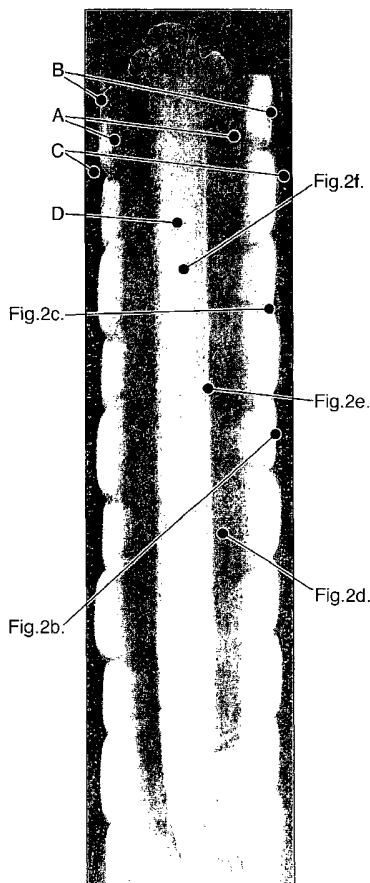

(57) Abstract: Two aluminium alloy work-pieces are welded together. Firstly, a por-
tion (2) of each work-piece (1) is prepared, the preparation including the performance
of a surface treatment, such as friction stir welding, that results in a region (A) ex-
tending from the exterior surface into the work-piece having a grain structure that is
finer than the grain structure of the work-piece outside (region C) that region. Then
the work-pieces are welded together by means of a fusion welding process, such as electron
beam welding, that joins the respective prepared portions (2) of the two work-pieces (1).
The preparation of the work-pieces is so performed that said region (A) extends into
the work-piece to a depth that exceeds the depth of material (region D) that is caused
to melt during the fusion welding process.

WO 2004/039527 A2



European patent (AT, BE, BG, CH, CY, CZ, DE, DK, EE, ES, FI, FR, GB, GR, HU, IE, IT, LU, MC, NL, PT, RO, SE, SI, SK, TR), OAPI patent (BF, BJ, CF, CG, CI, CM, GA, GN, GQ, GW, ML, MR, NE, SN, TD, TG).

For two-letter codes and other abbreviations, refer to the "Guidance Notes on Codes and Abbreviations" appearing at the beginning of each regular issue of the PCT Gazette.

Published:

— *without international search report and to be republished upon receipt of that report*

Welding method

The present invention relates to welding two metal work-pieces together and relates in particular, but not exclusively, to welding together two relatively thick work-pieces made from metal alloys that have been
5 prepared for use in the manufacture of aircraft components.

When manufacturing aircraft components it is sometimes necessary or desirable to weld together thick work-pieces for example solid blocks of aluminium alloy
10 having a thickness of 50mm or greater. The alloy will typically be an aluminium alloy that has been treated so that it has certain mechanical properties necessary for the alloy to be suitable for use in the manufacture of aircraft components. As a result, the microstructure of
15 the alloy is formed of relatively coarse elongate grains that are generally oriented parallel to each other. Welding blocks of aluminium of such a thickness is generally performed by means of a fusion welding process such as an electron beam (EB) welding process. It is
20 common when joining blocks of aluminium in this way for cracks to form (for example micro-cracks) in or near the region of the weld. Such cracks weaken the welded component particularly under fatigue loading.

It is an object of the present invention to produce
25 a method of welding two work-pieces together that eliminates or reduces the formation of cracks during the welding process as compared to the known prior art method described above.

According to the present invention there is provided
30 a method of welding together two metal work-pieces, the method including the following steps:

providing two metal work-pieces,

preparing a portion of each work-piece, the preparation including the performance of a surface treatment that results in a region extending from the exterior surface into the work-piece having a grain
5 structure that is finer than the grain structure of the work-piece outside that region, and

welding together the work-pieces by means of a fusion welding process that joins the respective prepared portions of the two work-pieces,

10 wherein said region extends into the work-piece to a depth that exceeds the depth of material that is caused to melt during the fusion welding process.

It has been found that the treating of the metal in the region of the weld joint to be formed mitigates the
15 problems associated with the formation of cracks. It has been observed that the formation of at least some cracks in the methods of the prior art tends to occur in the work-piece near the interface between the alloy and the weld, in regions where there has been partial
20 liquification of the alloy due to the heat generated when welding. Such cracks are often referred to as liquation cracks and commonly occur at the boundary between adjacent grains in the alloy. It is thought that such cracks result from the formation of grain boundary liquid
25 (at temperatures below the melting point of the grains of the alloy), which, being unable to support the tensile stresses that are developed as a result of the temperature changes during and after welding, leads to cracks forming along the grain boundary.

30 The average maximum dimension of the grains in the work-piece outside the region that has been subjected to said surface treatment is preferably at least five times greater than the average maximum dimension of the grains in the work-piece inside the region. Alternatively or

additionally, the method is performed such that there is at least one cross-section in which the difference between the grain size number of the material in the work-piece outside the region that has been subjected to
5 said surface treatment and the grain size number of the material in the work-piece inside the region is greater than or equal to 4. The grain size number, G , of a material is defined by the equation $n = 2^{G-1}$, where n = the number of grains per square inch at 100X
10 magnification (i.e. the number of grains in an area of 0.0645mm^2).

The preparation of the work-pieces may, if necessary, include a step of treating or machining the surface treated regions of each work-piece to produce a
15 surface on one work-piece that can be fusion welded to a corresponding surface on the other work-piece. The regions subjected to said surface treatment may for example be skimmed to produce substantially flat surfaces. The skimming of the work-pieces may for
20 example be performed by a milling machine. The skimming may typically remove a layer of material from a face of the work-piece that, had the work-piece not been subjected to said surface treatment, would have been about 0.5mm thick. The depth of material removed during
25 skimming will of course depend on the amount of material that needs to be removed in order to provide a flat surface, which will of course depend on the surface treatment employed.

The surface treatment of the metal is preferably
30 performed within a region that encompasses the region that will liquefy during the fusion welding process. The region that will liquefy may for example at the lowest be about 2mm, and may be as high as 5mm (or even higher depending on the fusion welding method employed), to

either side of the weld joint. In the case where the depth of liquefaction during fusion welding is 2mm to either side of the joint, the surface treating of the metal beforehand must extend beyond that depth, for example to a depth of at least 5mm. In the case where the surface of the work-piece is skimmed between the steps of surface treatment and fusion welding, then the depth of the material that has been subjected to said surface treatment will of course be reduced. The surface treatment may be conducted to a depth of at least 10mm. The surface treatment may be conducted to a depth of less than 100mm. The surface treatment may for example be conducted to a depth of between 5mm and 40mm and more preferably to a depth of between 10mm and 30mm. It will of course be understood that the surface treatment is referred to as such only because the treatment is effected near the surface of the work-piece and that the term is not limited to treatments where the treatment affects only the surface properties of the work-piece.

It will be appreciated that, depending on the depth to which the metal is subjected to said surface treatment, the fusion welding process may generate a heat affected zone (i.e. a zone in which the mechanical properties of the metal/alloy, such as for example hardness, are altered by the heat generated during welding) that extends beyond the boundary of the metal that has been subjected to said surface treatment.

The surface treatment is preferably so performed that the temperature of the metal does not reach the melting temperature of the metal work-piece. Advantageously, the surface treatment is performed such that the temperature of the metal does not exceed the eutectic phase melting temperature. Preferably, the surface treatment is performed such that the temperature

of the metal does not exceed the liquation temperature of the metal in the grain boundaries.

Advantageously, the performance of the surface treatment causes plasticization of the metal, but preferably causes substantially no liquefaction or fluidization. Preferably, the surface treatment causes substantially no melting of the metal.

Advantageously, the surface treatment is performed by means of a friction stir welding process. Such a process is described in US Patent No. 5,460,317 (Thomas et al), US 5,813,592 (Midling et al), WO 93/10935 (The Welding Institute), and WO 95/26254 (Norsk Hydro A.S.), the specifications of which are hereby fully incorporated herein by reference thereto. The friction stir welding process may be in the form of a process as described in any of those references. It will be understood that the term "friction stir welding" encompasses any method of welding in which a probe of material harder than the work-piece material is caused to move relative to the work-piece to generate frictional heat causing the work-piece in the region of the probe to become plasticised, the probe effectively entering the work-piece. The probe is conventionally caused to rotate about the probe axis and to move along the work-piece along the length of the weld to be formed.

The fusion welding process is conveniently performed by means of an electron beam welding process. Other fusion welding processes could be utilised but, of the methods currently available, electron beam welding is preferred because of the depth of weld achievable at relatively low weld widths.

The work-pieces may be made from low-density alloys. For example, the density of the metal is preferably less than $5,000 \text{ Kg m}^{-3}$, more preferably less than $4,000 \text{ Kg m}^{-3}$,

and yet more preferably less than $3,000 \text{ Kg m}^{-3}$. The work-pieces are preferably made from lightweight alloys. The work-pieces may be made from aluminium alloys. The work-pieces may be made from cold-worked metal. The cold-worked metal may for example have been subjected to a rolling process. The method is of particular application in the case where the work-pieces are suitable for use in the manufacture of an aircraft or aerospace component. For example, the metal may be any conventional or suitable alloy used in the aerospace industry, such as 2000 series, 6000 series, 7000 series aluminium alloys, or aluminium-lithium alloys. Such alloys have in the past been viewed as being difficult to weld together satisfactorily, especially where the depth of the joint to be welded is greater than or equal to about 50mm. Such alloys may be difficult to weld satisfactorily due to one or more of several factors including a) the complexity of the alloying system, b) the particular heat treatment(s) to which the alloy has previously been subjected, c) the mechanical/chemical structure/composition of the material, d) the particular arrangement of different phases in the alloy or of precipitates formed in the alloy and/or e) the size and/or orientation of the grains of the alloy material.

The two work-pieces may, but need not be, of the same type of material. The method of the present invention is for example advantageously able to be used to weld together different metals or alloys. For example, the method of the present invention could be utilised when manufacturing a component, one part of which being required to have one set of mechanical/physical properties and another part of the component being required to have a different set of mechanical/physical properties.

The method may of course be performed to weld together one or more other work-pieces, possibly welding the multiplicity of work-pieces together simultaneously or possibly welding the multiplicity of work-pieces together in series (sequentially).

The work-pieces may be in the form of blocks of material. The blocks of material after having been welded together may for example be machined into a component. The present invention thus also provides a method of manufacturing a component, for example an aircraft component, wherein the component is machined from a block of metal, the block of metal having been made from two or more work-pieces welded together in accordance with the method according to the present invention as described above. The block or blocks may conveniently, but not necessarily, be cuboid in shape. The size and shape of the work-pieces to be welded together may be, and possibly need only be, limited by the limitations of the fusion welding process employed. For example, it is possible to weld with a 120 kW (120kV operating at up to 1000mA) electron beam welding apparatus to depths of up to 450mm. With such an apparatus it would be possible to weld together two work-pieces having a thickness of 450mm by means of a single pass electron beam weld. If a dual pass (i.e. one welding pass on each side of the joint to be welded) electron beam weld process is utilised, the thickness of work-pieces able to be joined could be as high as 900mm. Greater thicknesses of material could be welded together with more powerful fusion welding equipment. Whilst a dual pass electron beam welding process is possible, a single pass process is preferred, because of the potential difficulties in ensuring a high quality weld

joint in the region where the two electron beam welds interface.

It will be appreciated that the work-pieces may be trimmed and/or machined after performance of the method of the present invention and that therefore the integrity of the weld joint in the regions of the work-piece that are subsequently removed is not important. There may also be other regions where the integrity of the joint between the work-pieces is not important for other reasons. For example, the work-pieces once joined might be machined into a component that in use is subjected to forces/stresses such that the strength of weld joint required varies across the joint. In such cases, the portions of the respective work-pieces being welded together in accordance with the present invention may actually be contained within larger regions that have been subjected to a surface treatment, or similarly prepared.

According to another aspect of the invention there is provided a method of manufacturing an aircraft component including the following steps:

providing two metal work-pieces,
preparing a portion of each work-piece, the preparation including the performance of a surface treatment that results in a region extending from the exterior surface into the work-piece having a grain structure that is finer than the grain structure of the work-piece outside that region, and

welding together the work-pieces by means of a fusion welding process that joins the respective prepared portions of the two work-pieces,

wherein said region extends into the work-piece to a depth that exceeds the depth of material that is caused to melt during the fusion welding process.

According to a further aspect of the invention there is provided a method of welding together two metal work-pieces, the work-pieces being made from a lightweight alloy suitable for use in the manufacture of an aircraft component, the method including the following steps:

5 providing two metal work-pieces,
preparing a portion of each work-piece, the preparation including the performance of a surface treatment that results in a region extending from the exterior surface into the work-piece having a grain structure that is finer than the grain structure of the work-piece outside that region, and

10 welding together the work-pieces by means of a fusion welding process that joins the respective prepared portions of the two work-pieces,

15 wherein said region extends into the work-piece to a depth that exceeds the depth of material that is caused to melt during the fusion welding process. The present invention also provides a component made from two work-pieces welded together in accordance with the method of the present invention as described herein. The component may be in the form of an aerospace component, an aircraft component or any other component that is required to have similar alloy material properties. The component may for example be in the form of a spar for an aircraft wing box. The spar may be over 10 metres long. The billets of the alloy that are supplied to the aircraft manufacturer may have a maximum dimension of 5 metres. Such a spar may be manufactured from those billets by

20 welding a plurality, three for example, billets end to end by means of the method of the present invention and then machining the spar from the resulting block.

25

30

The invention further provides a component comprising a weld joint joining one part of the component

to an adjacent part of the component, the component in the region of the joint comprising a portion, that has been fusion welded, sandwiched between two portions that have each been friction stir welded. The component may
5 be in the form of an aerospace component, an aircraft component or any other similar component.

It will be appreciated that features described with reference to one aspect of the invention may be incorporated into other aspects of the invention. For
10 example, the component, for example an aircraft component, according to the present invention may be made by means of the method of the present invention.

It will be appreciated that a component formed by means of the present invention may require further
15 processing before assembly. The component may therefore, in certain circumstances, be considered as an intermediate, requiring further processing before being considered as a finished article. For example, the component may require further machining, treating,
20 assembly with other parts, or any other such processes. It will therefore be understood that the term component is used herein both to cover the case where the component is in a state ready for final assembly and the case where the component is at an earlier stage in the component's
25 manufacture.

According to a preferred aspect of the invention there is also provided a method of welding together two work-pieces, the method including the following steps:
providing two metal work-pieces,
30 friction stir welding a region of each work-piece, preparing the friction stir welded regions of each work-piece to produce a surface on one work-piece that can be fusion welded to a corresponding surface on the other work-piece, and

fusion welding the respective prepared surfaces of the two work-pieces together, thereby joining the work-pieces.

Embodiments of the present invention will now be described by way of example only with reference to the accompanying drawings, of which:

- Figure 1a illustrates schematically the welding together of two metal plates according to a first embodiment of the invention;
- Figure 1b shows a portion of one of the plates shown in Figure 1a during a friction stir welding process;
- Figure 1c shows a cross-section of the portion of the plate shown in Figure 1b;
- Figure 2a shows a cross-section of the final welded joint formed by means of the first embodiment;
- Figures 2b to 2f show magnified portions of Figure 2a;
- Figure 2g shows a portion of Figure 2a illustrating the different regions of the weld;
- Figure 3 shows a magnified portion of an alloy that has been friction stir welded;
- Figure 4 shows a magnified portion of an alloy that has been electron beam

welded in accordance with a prior art method;

Figure 5 illustrates schematically the welding together of three aluminium billets according to a second embodiment of the invention; and

Figure 6 shows a wing spar machined from two billets in accordance with a third embodiment.

10 The first embodiment of the invention relates to an experiment in which two rolled plates were welded together. The rolled plates 1 before being joined are illustrated schematically in Figure 1a. The plates were made by rolling in the longitudinal direction of the plates (represented by arrow L in the drawings). The direction of the width of the plate is represented by arrow LT (i.e. the Long Transverse direction). The direction of the thickness of the plate is represented by arrow ST (i.e. the Short Transverse direction). The rolled plates 1 have a thickness t (in direction ST) of 150mm. The plate was made from a 7000 series aluminium alloy in T7651 temper condition. The alloy used comprises Aluminium, Zinc, Copper and Magnesium. The alloy had a relative high content of zinc (>6 wt.%). 20 This alloy was chosen because of the known difficulties associated with fusion welding the alloy.

The microstructure of the respective sides 2 of the plates 1 to be joined was modified using a friction stir welding process. The tool used in friction stir welding process had a 30mm shoulder diameter and a pin having a length of 12.05mm. The pin used has a cross-section that tapers (the cross-section becomes progressively smaller)

along its length, the angle of the taper being 10 degrees, from a diameter of 14mm at its widest at the top of the pin (immediately beneath the shoulder). Ten overlapping bead-on-plate weld runs were performed in the LT (Long Transverse) direction on the side 2 of each plate 1 using the following welding parameters: tool rotation = 190 rpm, welding speed = 150 mm/min and vertical force (i.e. down the length of the tool) = 61 kN. To avoid material overheating during the welding process, on completion of each weld run (each bead-on-plate weld) the plate was allowed to cool to room temperature before the next weld run was commenced. Figure 1b shows schematically a portion of the plate 1 including the side 2 of the plate after welding. Figure 1c shows the plate in cross-section (the section being taken across plane C-C, which plane has a normal axis that is parallel to the LT direction). As can be seen in Figure 1c, the successive weld runs 3 were performed such that there was a 10mm separation w_s between neighbouring weld centre-lines $w_1, w_2, w_3 \dots w_{10}$. The tool achieved a 12mm weld penetration. Thus, as can be seen in Figure 1b, a welded region having a width w_w of at least 100mm (in the ST-direction) and a depth w_d of about 12mm deep (in the L-direction) was formed. As such, the parent material structure (having a coarse grain structure) was changed into a typical friction stir weld structure (a fine grain structure).

After the friction stir welding step was completed, the top surfaces of the welds were skimmed, thereby removing about 1.0 - 1.5mm of material from the sides 2 to be welded together, thereby forming a smooth flat surface. Both plates were also machined to trim their thickness (in the ST direction) so that the surface of the side 2 of the plate 1 to be welded was 100mm thick,

the entire surface on that side 2 thus having been affected by the friction stir welding process (thereby providing a fine grain structure).

The two plates 1 were assembled in a vacuum chamber with the use of tack welds to form a 100mm thick (in the ST direction) butt joint running in the LT direction. Run-in and run-out plates were positioned either side of the butt joint and the joint was backed by a backing plate. Electron beam welding was then performed horizontally in the LT direction with a vertical beam and using the following welding parameters: accelerating voltage = 60 kV, beam current = 450 mA, focus current = 610 mA, welding speed = 240 mm/min, vacuum in the chamber = 2×10^{-4} torr, beam oscillation = 1.2mm diameter circle and an oscillation frequency = 800 Hz.

The welded joint so produced is shown in Figures 2a to 2g. Figure 2a shows a cross-section of the weld joint, the section being taken in the plane parallel to the ST and L directions and having its normal axis parallel to the LT direction. Figure 2g shows a portion of Figure 2a (rotated by 90 degrees) illustrating the various regions A, B, C, D of the weld. As can be seen in Figures 2a and 2g, the electron beam weld (region D) is formed between the two plates 1 and is sandwiched between the friction stir welding regions A on each respective plate 1. Beyond the friction stir welding region A is the parent alloy of the plate 1, represented by region C. The interface between regions A and C is represented by region B. Region B, being relatively narrow compared to regions A and C, is represented in Figure 2g by the dotted white line that divides regions A and C.

The average width of the electron beam weld is about 5 mm. The average width of regions A-D-A combined is

about 20 mm. The width of the heat affected zone of the electron beam weld is very approximately 30 mm.

Figure 2b shows a region of Figure 2a magnified to show the grain structure at the interface (region B) between the friction stir weld region A and the parent alloy (region C). The left-hand side area of Figure 2b shows the shearing of the alloy and shows that the grains become progressively smaller as one moves from region C (the right of Fig. 2b) to region A (the left of Fig. 2b). Figure 3 shows a separate sample in cross-section illustrating more clearly the size and orientation of the grains in regions A, B, and C. As can more clearly be seen in Figure 3, the grains in region A (the region that has been friction stir welded) are much finer than the coarse grains in region C (of the unwelded parent alloy). It will be observed that no cracks are apparent in either Figures 2b or 3. The difference between the grain size number, G_A , of the alloy in region A and the grain size number, G_C , in region C is greater than 3.

Figure 2c shows a region of Figure 2a magnified (at the same magnification as Fig. 2b) to show the grain structure at the interface (region B) between two neighbouring friction stir welds and the parent alloy (region C). Again, whilst the grains have been sheared, the transition between the parent alloy (to the right in Figure 2c) and the adjacent friction stir welded regions (to the left in Figure 2c) is gradual. It will again be observed that no cracks are present.

Figure 2d shows a region of Figure 2a magnified (at about 2.5 times the magnification of Figs. 2b and 2c) to show the grain structure in the friction stir welded region A. The grains in region A are relatively fine compared to the grains in region C (taking into account the difference in magnification between Figures 2b and 2c

on the one hand and Fig. 2d on the other). Again, there is no evidence of any cracking or faults.

Figure 2e shows a region of Figure 2a magnified (at the same magnification of Fig. 2d) to show the grain structure at the interface between the friction stir weld region A (the right hand side of Fig. 2e) and the electron beam welded region D (the left hand side of Fig. 2e). The grains in this interface region are relatively fine. The interface between the two regions is gradual and therefore difficult to identify, especially as the grain size and orientation in each region are very similar. Figure 2e shows however that the interface between the electron beam weld and the friction stir weld region is of very high quality. Yet again, there is no evidence of any cracking or faults.

Figure 2f shows a region of Figure 2a magnified (at the same magnification of Figs. 2d and 2e) to show the grain structure within the electron beam welded region D. Again, the grains in this interface region are relatively fine and are of a similar size to, although very slightly larger than, the grains in the friction stir welded region A. Whilst none would be expected in any case, it will be seen that no cracks are evident in this region D.

Figures 2a to 2g illustrate that the present embodiment may be utilised to produce high quality welds, without liquation cracking, on alloys where it has generally been considered difficult, if not impossible, to form welds on joints having any substantial thickness. The limit on the thickness of the joint of the present invention will probably be determined by the limit of the thickness to which the fusion welding (in this embodiment, electron beam welding) can be effected satisfactorily.

By way of comparison, Figure 4 shows a cross-section of a joint made between two plates of the same alloy as used in the first embodiment, without the step of friction stir welding. The electron beam weld is shown as region D and is sandwiched directly between two regions C of parent alloy (of the two plates, respectively). As can be seen in Figure 4, cracks E have formed as a result of the electron beam welding.

Figure 5 illustrates schematically a second embodiment of the present invention. Three billets 1 of aluminium alloy suitable for forming an aircraft component are welded together end to end to form an elongate block of aluminium alloy. Each billet measures 5m x 2m x 200mm. Adjacent end faces 2 of the billets 1 are welded together by means of a method similar to that described above in relation to the first embodiment of the invention. Almost the entire surface of each end face 2, of each billet to be welded to an adjacent billet, is friction stir welded to a depth of 25mm. Then the end faces so welded are skimmed by means of a milling machine that removes about 1mm of material from the end face. The top and bottom faces, abutting the end face, are also skimmed in preparation for the next step. Adjacent billets are then welded together by means of an electron beam welding process, thereby forming a solid block of alloy measuring about 15m x 2m x 200m. A spar for an aircraft wing is then machined from the single solid block. The spar is about 14m long.

According to a third embodiment, shown in Figure 6, two billets of different alloy material are welded together by means of the method of the second embodiment described above, although only two billets are joined in this embodiment. A first billet of 2000 series alloy measuring 100mm x 1m x 10m is joined to a second billet

of 7000 series alloy also measuring 100mm x 1m x 10m, thereby forming a block of material measuring 100mm x 2m x 10m. The resulting block is then machined into a spar, such as that shown in Figure 6. The spar has an upper portion 4 made of 7000 series alloy providing a high strength region, where strength is important, and a lower portion 5 made of 2000 series alloy providing a region where a high damage tolerance is more important than strength. The weld line between the two portions 4, 5 is labeled with reference numeral 6 in Figure 6

It will, of course, be appreciated that various modifications may be made to the above-described embodiments without departing from the spirit of the present invention. For example, components (such as for example a wing rib or a section of the wing skin) other than a wing spar could be machined from the billets of aluminium once welded together. Rather than electron beam welding, other fusion welding processes could be employed, such as laser welding. The invention has application in relation to alloys other than Aluminium alloys including for example Magnesium alloys. Other modifications will, of course, be apparent to the person skilled in the art.

Claims

1. A method of welding together two metal work-pieces, the method including the following steps:
- 5 providing two metal work-pieces,
preparing a portion of each work-piece, the preparation including the performance of a surface treatment, including a friction stir welding process, that results in a region extending from the exterior
- 10 surface into the work-piece having a grain structure that is finer than the grain structure of the work-piece outside that region, and then
- welding together the work-pieces by means of a fusion welding process that joins the respective prepared
- 15 portions of the two work-pieces,
wherein said region extends into the work-piece to a depth that exceeds the depth of material that is caused to melt during the fusion welding process.
- 20 2. A method according to claim 1, wherein the surface treatment is conducted to a depth of at least 10mm into each work-piece and wherein the depth of the joint to be fusion welded is greater than 50mm.
- 25 3. A method according to any preceding claim, wherein the surface treatment is performed such that there is at least one cross-section in which the difference between the grain size number of the material in the work-piece outside the region that has been subjected to said
- 30 surface treatment and the grain size number of the material in the work-piece inside the region is greater than or equal to 4.

4. A method according to any preceding claim, wherein the step of preparing the work-pieces includes a step of treating or machining the surface-treated regions of each work-piece to produce a surface on one work-piece that
5 can be fusion welded to a corresponding surface on the other work-piece.
5. A method according to any preceding claim, wherein the fusion welding process is performed by means of an
10 electron beam welding process.
6. A method according to any preceding claim, wherein the work-pieces are made from aluminium alloys.
- 15 7. A method according to any preceding claim, wherein the work-pieces are made from cold-worked metal.
8. A method according to any preceding claim, wherein the work-pieces are suitable for use in the manufacture
20 of an aircraft component.
9. A method of welding together two work-pieces, the method including the following steps:
providing two metal work-pieces,
25 friction stir welding a region of each work-piece,
preparing the friction stir welded regions of each work-piece to produce a surface on one work-piece that can be fusion welded to a corresponding surface on the other work-piece, and
30 fusion welding the respective prepared surfaces of the two work-pieces together, thereby joining the work-pieces.

10. A method of welding together two metal work-pieces, the method including the following steps:

providing two metal work-pieces,

preparing a portion of each work-piece, the
5 preparation including the performance of a surface treatment that results in a region extending from the exterior surface into the work-piece having a grain structure that is finer than the grain structure of the work-piece outside that region, and

10 welding together the work-pieces by means of a fusion welding process that joins the respective prepared portions of the two work-pieces,

wherein said region extends into the work-piece to a depth that exceeds the depth of material that is caused
15 to melt during the fusion welding process.

11. A method of manufacturing an aircraft component, wherein the aircraft component is machined from a block of metal, the block of metal having been made from two or
20 more work-pieces welded together in accordance with the method as claimed in any preceding claim.

12. A component made from two work-pieces welded together in accordance with the method as claimed in any
25 of claims 1 to 10.

13. A component comprising a weld joint joining one part of the component to an adjacent part of the component, the component in the region of the joint comprising a
30 portion, that has been fusion welded, sandwiched between two portions that have each been friction stir welded prior to the formation of the fusion welded portions.

14. A component according to claim 12 or 13, wherein the component is an aircraft component.

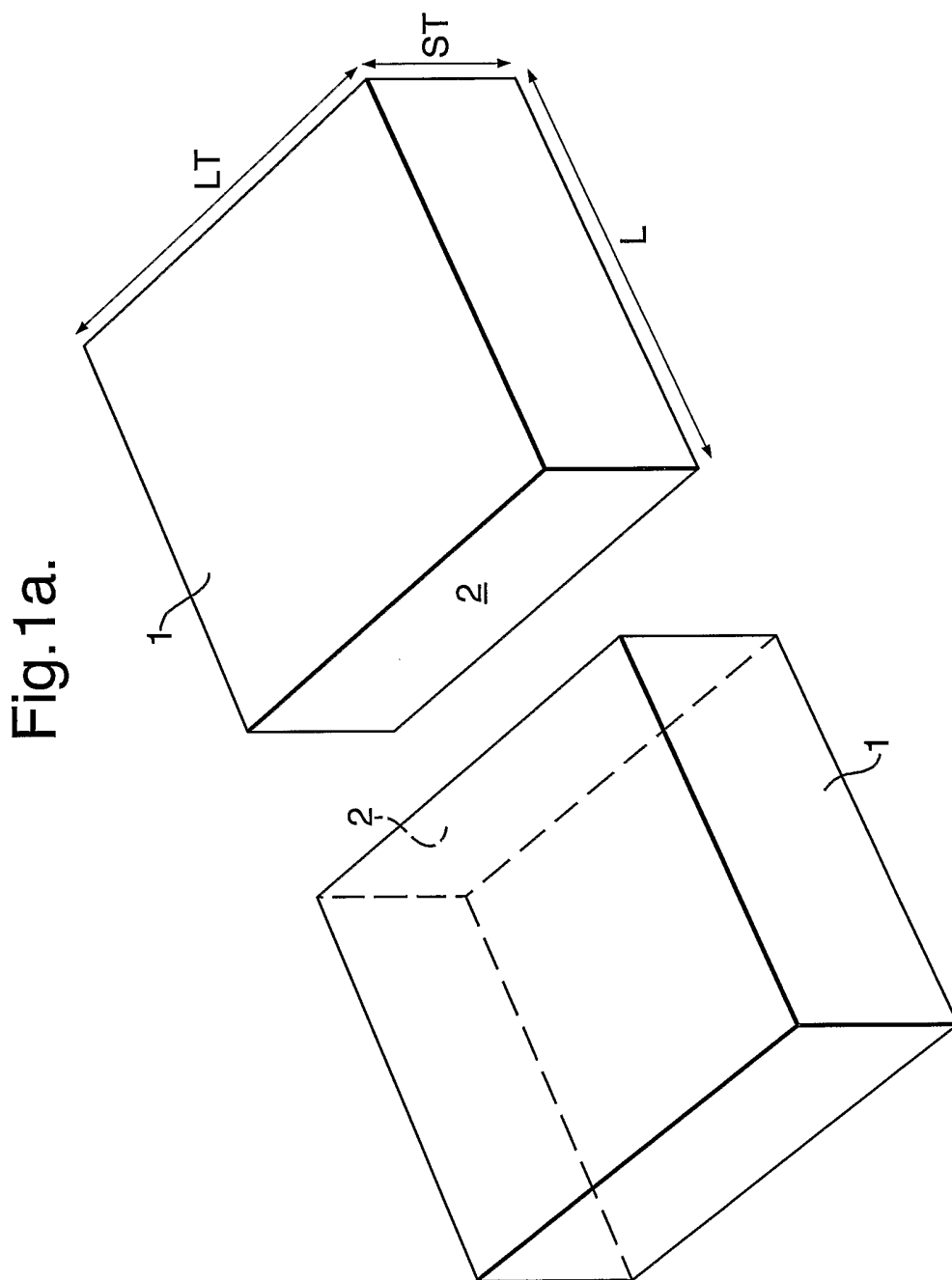

Fig.1c.

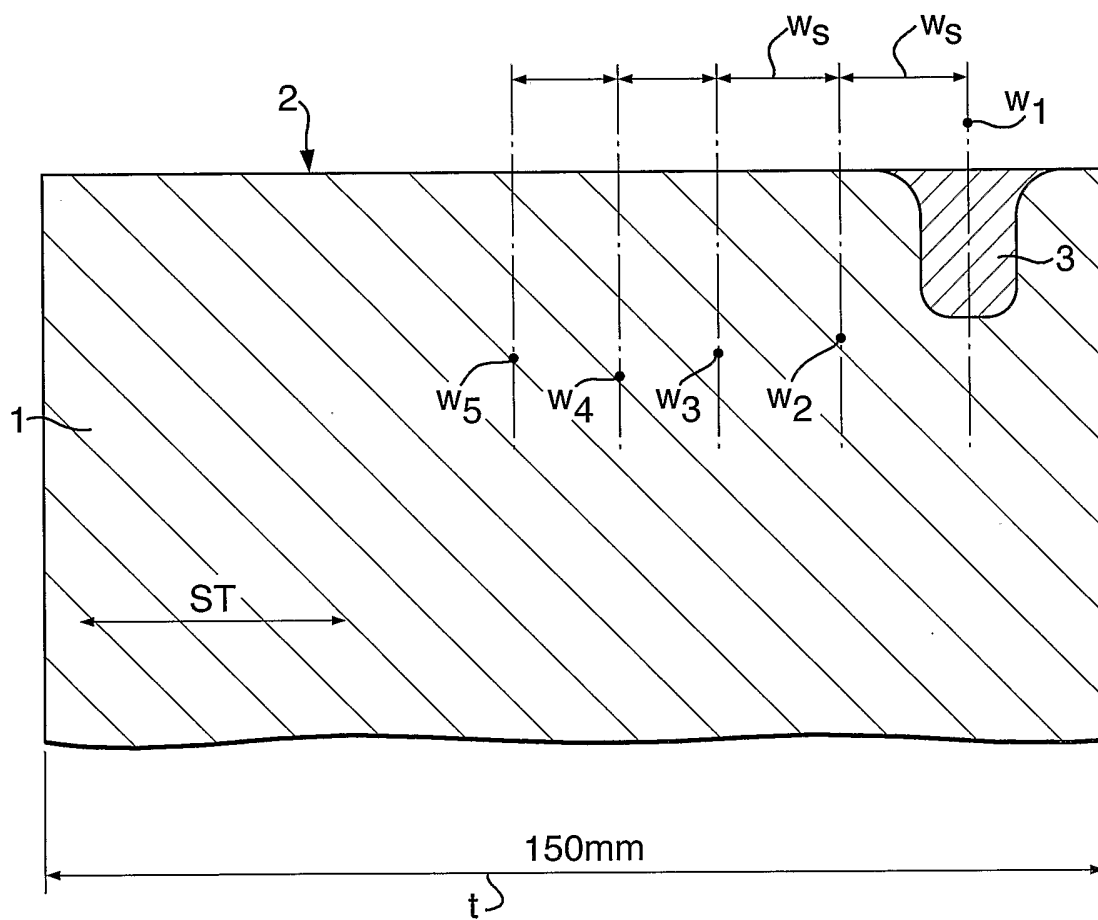

Fig.2a.

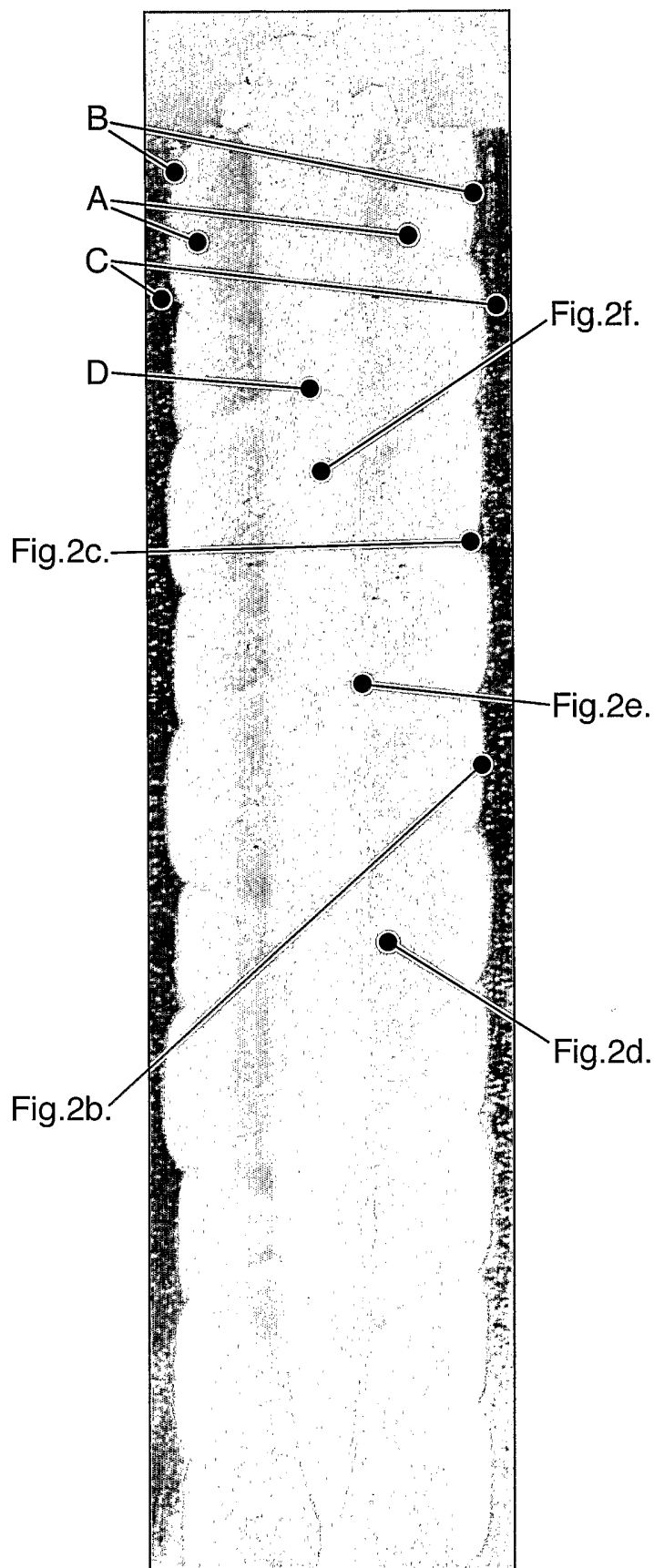

Fig.2b.

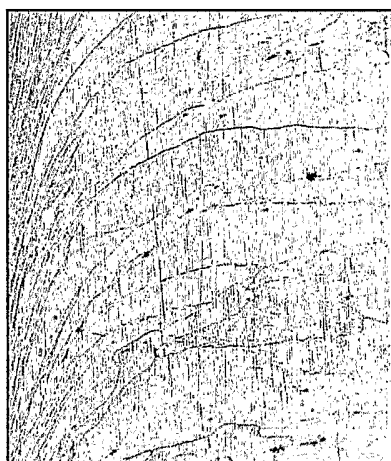

Fig.2c.



Fig.2d.

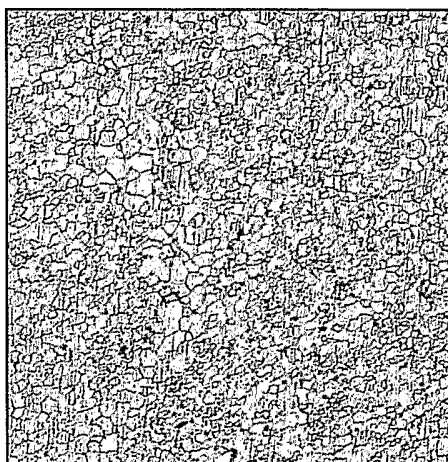

Fig.2e.

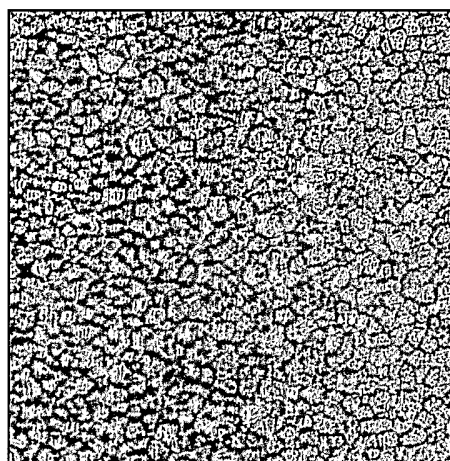

Fig.2f.

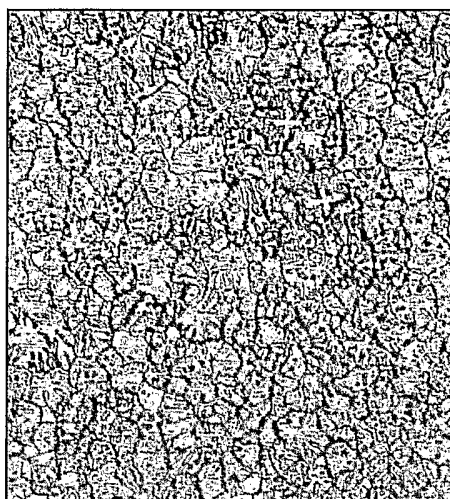
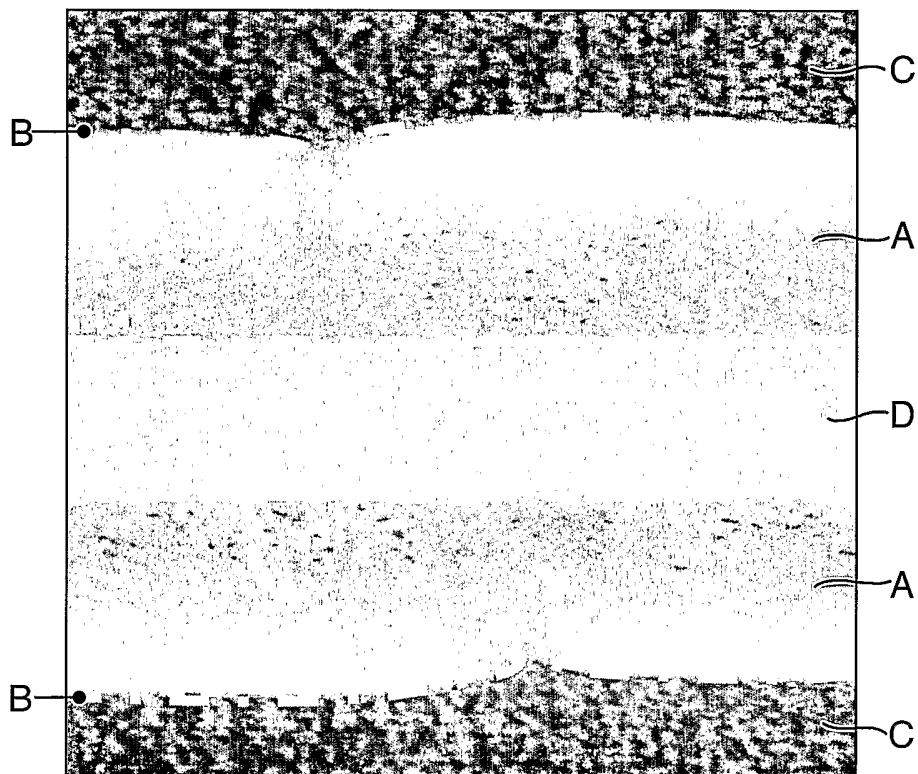

Fig.2g.



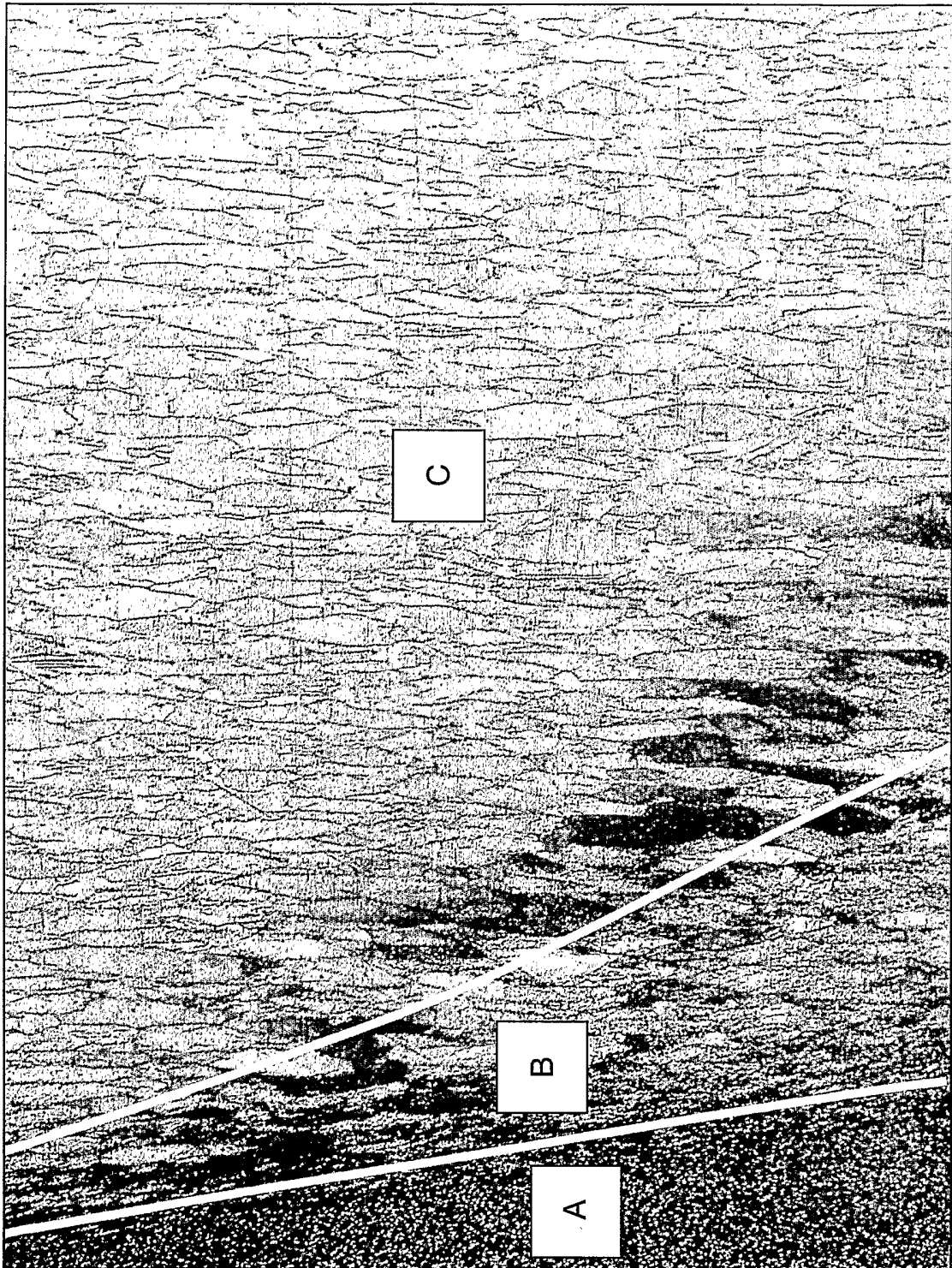

Fig.3.

Fig.4.

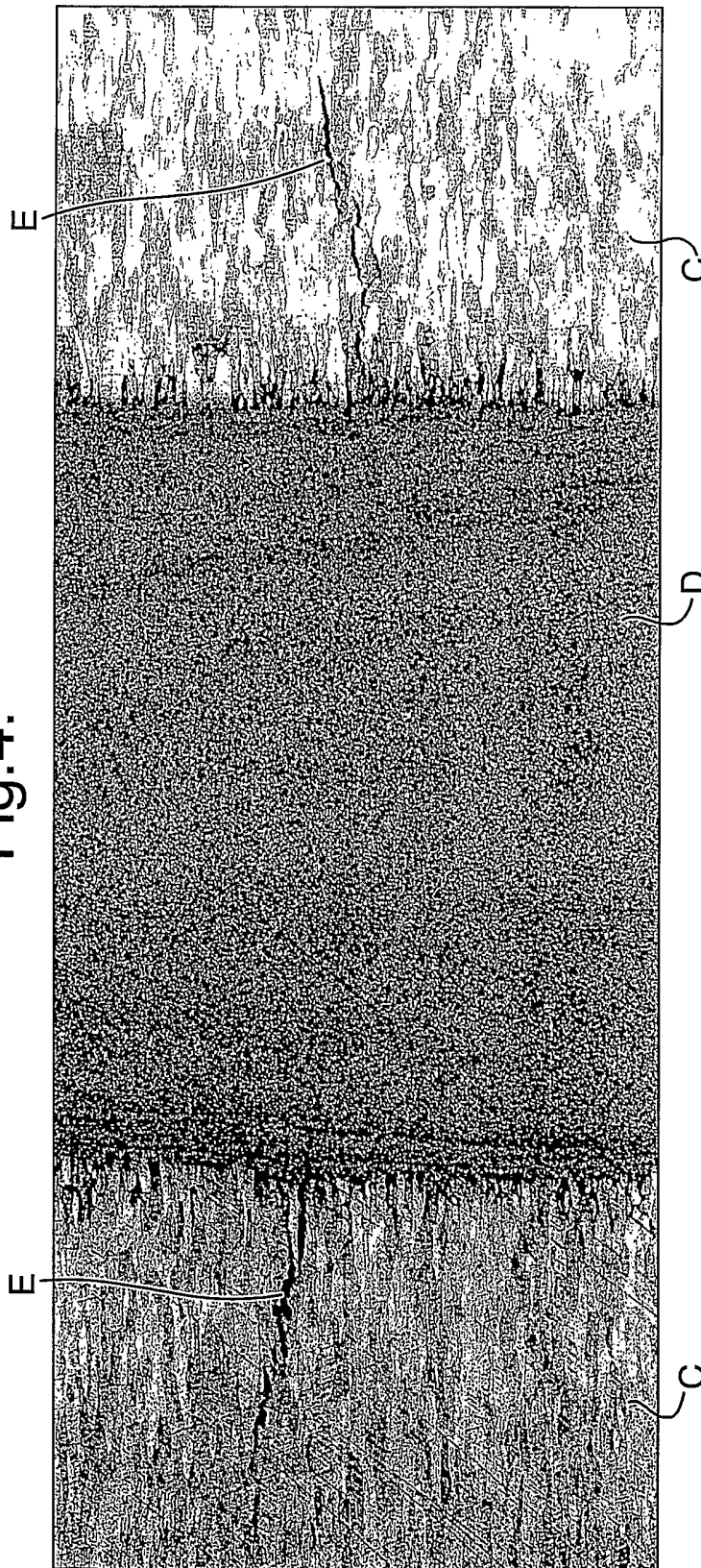

Fig.5.

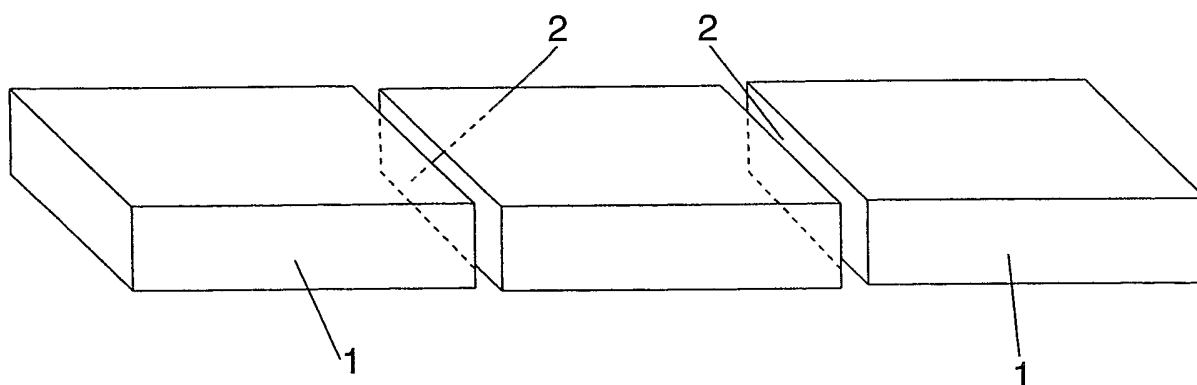

Fig.6.

