



(43) International Publication Date  
03 December 2020 (03.12.2020)

- (51) International Patent Classification:  
G08C 17/02 (2006.01) G06F 3/16 (2006.01)
- (21) International Application Number:  
PCT/AU2020/050524
- (22) International Filing Date:  
26 May 2020 (26.05.2020)
- (25) Filing Language: English
- (26) Publication Language: English
- (30) Priority Data:  
2019901805 27 May 2019 (27.05.2019) AU
- (71) Applicant: LA TROBE UNIVERSITY [AU/AU]; Plenty Road, Bundoora, Victoria 3086 (AU).
- (72) Inventors: HOGAN, Conor; C/o - La Trobe University, Plenty Road, Bundoora, Victoria 3086 (AU). ELTON, Darrell; C/o - La Trobe University, Plenty Road, Bundoora, Victoria 3086 (AU).
- (74) Agent: GRIFFITH HACK; Level 10, 161 Collins Street, Melbourne, VIC 3000 (AU).
- (81) Designated States (unless otherwise indicated, for every kind of national protection available): AE, AG, AL, AM, AO, AT, AU, AZ, BA, BB, BG, BH, BN, BR, BW, BY, BZ, CA, CH, CL, CN, CO, CR, CU, CZ, DE, DJ, DK, DM, DO, DZ, EC, EE, EG, ES, FI, GB, GD, GE, GH, GM, GT, HN, HR, HU, ID, IL, IN, IR, IS, JO, JP, KE, KG, KH, KN, KP, KR, KW, KZ, LA, LC, LK, LR, LS, LU, LY, MA, MD, ME,

MG, MK, MN, MW, MX, MY, MZ, NA, NG, NI, NO, NZ, OM, PA, PE, PG, PH, PL, PT, QA, RO, RS, RU, RW, SA, SC, SD, SE, SG, SK, SL, ST, SV, SY, TH, TJ, TM, TN, TR, TT, TZ, UA, UG, US, UZ, VC, VN, WS, ZA, ZM, ZW.

(84) Designated States (unless otherwise indicated, for every kind of regional protection available): ARIPO (BW, GH, GM, KE, LR, LS, MW, MZ, NA, RW, SD, SL, ST, SZ, TZ, UG, ZM, ZW), Eurasian (AM, AZ, BY, KG, KZ, RU, TJ, TM), European (AL, AT, BE, BG, CH, CY, CZ, DE, DK, EE, ES, FI, FR, GB, GR, HR, HU, IE, IS, IT, LT, LU, LV, MC, MK, MT, NL, NO, PL, PT, RO, RS, SE, SI, SK, SM, TR), OAPI (BF, BJ, CF, CG, CI, CM, GA, GN, GQ, GW, KM, ML, MR, NE, SN, TD, TG).

**Published:**  
— with international search report (Art. 21(3))  
— before the expiration of the time limit for amending the claims and to be republished in the event of receipt of amendments (Rule 48.2(h))

(54) Title: WIRELESS ELECTROCHEMICAL ANALYSIS

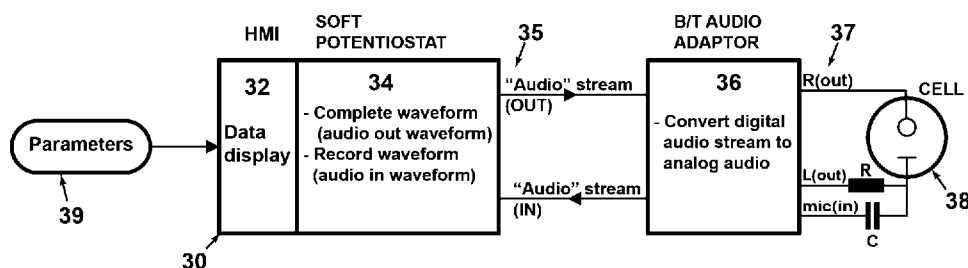

Figure 3

(57) Abstract: A system for sensing or measuring the concentration of an analyte. The system in use is connectable to an electrochemical sensor, and includes a computing device wirelessly connectable to an audio module, and being operable to stream audio data there between. The audio module comprises an audio signal output and an audio signal input, connectable to the electrochemical sensor, with the audio signal output being connected to an electrode of the electrochemical sensor and the audio signal input being connected to receive an output signal from the electrochemical sensor. The computing device causes the audio module to generate a desired output voltage waveform at its output. Simultaneously with generating the output voltage waveform, the audio module captures an input voltage waveform received at the audio signal input and transmits this to the computing device, to be recorded as a response waveform indicative of the concentration of the analyte.



## WIRELESS ELECTROCHEMICAL ANALYSIS

### FIELD OF THE INVENTION

[0001] This disclosure relates generally to electrochemical methods of analysis, and more particularly to a low-cost analysis system using widely available mobile and wireless computing technology.

### BACKGROUND TO THE INVENTION

[0002] Recent trends in the field of chemical sensors and biosensors have highlighted the importance of simplicity and low cost in determining whether sensing technologies have the capacity to be transformative to the lives of ordinary people, and available to those in remote or resource-poor environments. To this end, there has been considerable interest in the use of low-cost materials, such as paper, and low-cost fabrication techniques, such as printing, to produce microfluidic sensors which can be manufactured at minimal expense. A further area of interest has been reduction of the cost of detection instruments by, for example, the use of printed electronics co-located on disposable sensors.

[0003] One approach that has generated some interest is to employ mobile computing devices, such as smartphones or tablets, as components in sensing arrangements. Such devices have now reached market saturation in the developed world, and are rapidly becoming ubiquitous also in the developing world.

[0004] Through the use of mobile computing devices, costs can be reduced because the device may replace many back-end sensor functions, such as user interaction, data acquisition, signal processing and results display. Moreover, the connectivity of these devices holds the promise of facilitating telemedicine and helping to eliminate distance barriers, thereby improving access to medical services in remote and resource-poor communities.

[0005] However, most of the applications of mobile device technology for chemical sensing and/or bio-sensing have relied upon external active processing devices in order to perform key sensor functions. A typical example of such an arrangement is shown, in block diagram form, in Figure 1 of the accompanying drawings. In this example, a computer 2 running a simple Human Machine Interface (HMI), or Graphical User Interface (GUI), is used to control an attached potentiostat 4 via a control cable 9.

[0006] This is the most conventional way to perform electrochemical measurements and is extensively described in prior art publications. The potentiostat 4 in this configuration is a dedicated hardware device available in a wide range of complexities and costs. Regardless of complexity the conceptual operation is as follows.

[0007] The computer 2 converts user-entered electrochemical parameters 6 to a small data packet before being communicated to the attached potentiostat 4. This conventional hardware potentiostat 4, with its semi-autonomous capability, uses the parameters 6 contained in this data packet to generate an electrochemical excitation waveform. This waveform, through the use of a Digital to Analog Converter (DAC) and supporting analog electronics (op-amps) within the potentiostat is applied to an electrochemical sensor or cell 8. The resulting current from this cell is measured using an Analog to Digital Converter (ADC) and more supporting analog electronics (op-amps). The digitized current is converted into data packets by the potentiostat before being communicated back to the HMI/GUI of the computer 2 where it is displayed.

[0008] While such solutions provide a cost benefit over more conventional potentiostats with integrated sensors, they nonetheless involve additional costs over and above the availability of a suitable mobile device, as well as the inconvenience of carrying the additional external hardware apparatus.

[0009] To address these problems, the present inventors have previously developed a mobile voltammetric analysis system which is described in International (PCT) patent application number PCT/AU2017/050232 published as WO 2017/56584. The entire content of that PCT publication is incorporated into this disclosure by cross-reference.

[0010] Figure 2 of the accompanying drawings shows a schematic representation of the system disclosed in WO 2017/56584. The system includes a mobile computing device 10, such as a tablet or smart phone, having a HMI/GUI 12, microprocessor and memory 14, and an audio interface 16. The audio interface 16 comprises an audio signal output 17 having first and second channels (Rout, Lout) and an audio signal input in the form of a microphone input (Mic in). In use, the audio interface 16 is connected to a voltammetric cell 18 comprising first and second electrodes. The memory 14 of the device 10 contains instructions (in the form of an App) which, when executed by the microprocessor, cause the device 10 to: generate an output voltage waveform between the first and second channels (Rout, Lout) of the audio signal output 17; and simultaneously with generating the output voltage waveform, capture an input voltage waveform at the audio signal input (Mic in). This waveform is recorded within the memory 14 as a voltammetric response waveform indicative of an analyte concentration in the voltammetric cell.

[0011] In substance, the mobile computing device 10 disclosed in WO 2017/56584 and shown in Figure 2 acts as a “software potentiostat” (or “soft potentiostat”), as distinguished from the more conventional “hardware potentiostat” shown in Figure 1. All capture, recordal and processing of data is performed in software within the mobile computing device 10.

[0012] User-entered data is used to control the software potentiostat to perform a similar function to the hardware potentiostat shown in Figure 1, converting electrochemical parameters 19 to a calculated waveform data vector (namely, a one-dimensional array of numbers) representing a predetermined

excitation waveform defined by the electrochemical parameters 19. This waveform data vector is then used to control the on-board audio hardware 16 to produce an analog voltage at the headphone jack (Rout, Lout) which is connected to the voltammetric cell 18 via a simple resistor R and capacitor C. The microphone connection (Mic in) of this jack allows the electrochemical current passing through the resistor R to be measured and stored as an input waveform data vector to the “software potentiostat”.

[0013] While the software potentiostat described in WO 2017/56584 addressed many of the problems encountered with more traditional hardware potentiostats, which merely use the mobile computing device as a user interface, the inventors found that not all mobile computing devices are suitable. In particular, many commonly available mobile phones and tablets (such as iPhones and iPads) incorporate a DC blocking capacitor in the output stage of their audio interface. This makes these devices unsuitable, or at least less suitable, to produce the necessary output waveforms.

[0014] In the latter regard, the DC blocking capacitor represents a limitation on the types of electrochemical measurements possible. A very limited subset of electrochemical measurements – those carried out at high frequency / or short timescale (< approx. 5 ms) – could be carried out in a rudimentary fashion, using a phone with a DC blocking capacitor, and other types of measurement such as solution conductivity measurements are possible using a phone with a DC blocking capacitor. However, this precludes the vast majority of electrochemical measurements which require an excitation potential waveform with a timescale substantially longer than 5 ms.

[0015] It would also be desirable for such a mobile electrochemical analysis system to enable other forms of analysis to be conducted, for example using electrochemiluminescence (ECL) techniques wherein the intensity of light emitted from a detection zone of the electrochemical sensor is indicative of the concentration of an ECL active molecule. One example of a low-cost mobile ECL

sensing system is described in Australian Innovation Patent number AU20141000086. The entire content of that Innovation patent specification is incorporated into this disclosure by cross-reference.

[0016] In substance, the system described in the innovation patent is implemented in software within a mobile computing device such as a smartphone or tablet. The mobile computing device comprises a microprocessor, one or more memory components comprising a program and data store accessible to the microprocessor, an image sensor configured to acquire images and to transfer digital representations of the images to the program and data store, and an audio interface configured to generate electrical signals, which is operable under control of the microprocessor. The audio interface is connectable, in use, to electrical input terminals of a chemical sensor comprising a paper microfluidic layer loaded with electrochemilumescence (ECL) active molecules or a co-reactant within a detection zone, and a planar circuit layer comprising a working electrode in contact with the detection zone of the paper microfluidic layer. The device is programmed to apply an electrical stimulation signal to the working electrode via the audio interface, to acquire one or more images of the detection zone of the paper microfluidic layer via the image sensor, and to analyse a digital representation of the acquired images to determine an intensity of light emitted from the detection zone. A corresponding co-reactant or ECL active molecule concentration may thereby be computed based upon the intensity of the emitted light.

[0017] The inventors have also found that it is not always convenient to have a mobile phone or tablet physical and electrically connected to the electrochemical sensor/cell by a cable.

[0018] Accordingly, there remains an ongoing need to develop further low-cost sensing systems which are more universally implementable using commonly available mobile phones and/or tablets, and which remove the need to physically and electrically connect the mobile device directly to the electrochemical cell or

sensor. The present invention seeks to address this ongoing need, or at least to provide a useful alternative to existing low-cost sensing systems.

[0019] The reference in this specification to any prior publication (or information derived from it), or to any matter which is known, is not, and should not be taken as an acknowledgement or admission or any form of suggestion that the prior publication (or information derived from it) or known matter forms part of the common general knowledge in the field of endeavour to which this specification relates.

## SUMMARY OF THE INVENTION

[0020] One aspect of the present invention provides a system for sensing or measuring the concentration of an analyte, the system in use being connectable to an electrochemical sensor, with the system comprising:

- a computing device comprising a microprocessor, one or more memory components containing a program and data store accessible to the microprocessor, and a wireless communication interface; and

- an audio module, wirelessly connectable to the computing device via the wireless communication interface and being operable to stream audio data between the audio module and the computing device,

- the audio module comprising an audio signal output and an audio signal input,

- the audio module being connectable to the electrochemical sensor with the audio signal output being connected to an electrode of the electrochemical sensor and the audio signal input being connected to receive an output signal from the electrochemical sensor, and

- the program and data store containing instructions which, when executed by the microprocessor, cause the system to implement steps of:

- the computing device calculating an output waveform data vector representing a desired excitation waveform;

- the computing device transmitting the output waveform data vector to

the audio module;

the audio module generating an output voltage waveform at the audio signal output, with the output voltage waveform being defined by the output waveform data vector;

simultaneously with generating the output voltage waveform, the audio module capturing an input voltage waveform received at the audio signal input and converting the input voltage waveform to an input waveform data vector;

the audio module transmitting the input waveform data vector to the computing device; and the computing device recording within the data store the input waveform data vector as a response waveform indicative of the concentration of the analyte.

[0021] In one embodiment the audio signal output of the audio module comprises an output channel and a common ground reference. In use, the audio module is connectible to the electrochemical sensor with the output channel and common ground reference being connected to first and second electrodes of the electrochemical sensor. In this embodiment the output voltage waveform is generated between the output channel and the common ground reference.

[0022] In one example application the electrochemical sensor comprises a voltammetric cell having first and second electrodes. For this application the system also includes a circuit configuration comprising a resistor and capacitor for connecting the audio module to the voltammetric cell, with the output channel of the audio signal output being connected to the first electrode, the common ground reference of the audio signal output being connected to the second electrode via the resistor, and the audio signal input being connected to the second electrode via the capacitor. In this application the output voltage waveform preferably comprises a time-varying voltammetric driving potential and an AC perturbation, and the response waveform is indicative of a voltammetric response from the voltammetric cell.

[0023] In another embodiment the audio signal output of the audio module comprises first and second channels. In use, the audio module is connectible to the electrochemical sensor with the first and second channels of the audio signal output being connected to first and second electrodes of the electrochemical sensor. In this embodiment the computing device calculates first and second output waveform data vectors together representing the desired excitation waveform, and the computing device transmits both the first and second output waveform data vectors to the audio module. The audio module then generates an output voltage waveform between the first and second channels of the audio signal output, with the output voltage waveform being defined by the first and second output waveform data vectors.

[0024] More specifically, this embodiment of the invention provides a system for sensing or measuring the concentration of an analyte, the system in use being connectable to an electrochemical sensor, with the system comprising:

- a computing device comprising a microprocessor, one or more memory components containing a program and data store accessible to the microprocessor, and a wireless communication interface; and

- an audio module, wirelessly connectable to the computing device via the wireless communication interface and being operable to stream audio data between the audio module and the computing device,

- the audio module comprising an audio signal output having first and second channels and an audio signal input,

- the audio module being connectable to the electrochemical sensor with the first and second channels of the audio signal output being connected to first and second electrodes of the electrochemical sensor and the audio signal input being connected to receive an output signal from the electrochemical sensor, and

- the program and data store containing instructions which, when executed by the microprocessor, cause the system to implement steps of:

- the computing device calculating first and second output waveform data vectors together representing a desired excitation waveform;

- the computing device transmitting the first and second output waveform data vectors to the audio module;

the audio module generating an output voltage waveform between the first and second channels of the audio signal output, with the output voltage waveform being defined by the first and second output waveform data vectors;

simultaneously with generating the output voltage waveform, the audio module capturing an input voltage waveform received at the audio signal input and converting the input voltage waveform to an input waveform data vector;

the audio module transmitting the input waveform data vector to the computing device; and

the computing device recording within the data store the input waveform data vector as a response waveform indicative of the concentration of the analyte.

[0025] In one example application the electrochemical sensor comprises a voltammetric cell having first and second electrodes. For this application the system further comprises a circuit configuration comprising a resistor and a capacitor for connecting the audio module to the voltammetric cell, with a first channel of the audio signal output is connected to the first electrode, a second channel of the audio signal output is connected to the second electrode via the resistor, and the audio signal input is connected to the second electrode via the capacitor. For this application the output voltage waveform preferably comprises a time-varying voltammetric driving potential and an AC perturbation, and the response waveform is a voltammetric response from the electrochemical cell.

[0026] In one embodiment the instructions, when executed by the microprocessor, cause the audio module to generate the output voltage waveform by generating a first waveform comprising the voltammetric driving waveform; generating a second waveform comprising an inverse of the voltammetric driving waveform; superimposing the AC perturbation to one of the first and second waveforms; and applying the first waveform to the first channel of the audio signal output, and the second waveform to the second channel of the audio signal output.

[0027] In some embodiments the computing device is a mobile computing device such as a smartphone, tablet or laptop computer. However, any suitable form of computing device having a wireless communication interface could instead be used.

[0028] In some embodiments the wireless communication interface is a Bluetooth interface and communication between the audio module and the computing device involves streaming of data using a Bluetooth audio encoding method. However, any other suitable wireless communication interface, such as WiFi or other wireless technology, may be used to connect the audio module to the computing device.

[0029] Embodiments of the invention utilise the continuous data streaming capabilities of wireless audio devices to enable almost universally accessible voltammetric measurements, or other electrochemical analyses, without purpose-built electrochemical instrumentation.

[0030] In the later regard, the inventors have surprisingly found that some conventional wireless audio modules allow efficient streaming of electrochemical data to and from a mobile device, enabling un-wired instrument-free electrochemical analysis. The present invention makes use of this finding.

[0031] Nevertheless, in certain circumstances the inventors recognize that it may be more desirable to use a more general wireless transmitter-receiver module that enables bidirectional streaming of data representing a waveform. Such transmitter-receiver modules may not necessarily be intended to stream audio data and may instead be designed for other non-audio purposes. All that is required is that the transmitter-receiver module be capable of wirelessly receiving a waveform data vector from a computing device and generate a corresponding analogue output voltage waveform, and conversely, capture an analogue input voltage waveform and convert this to a corresponding waveform data vector for wireless transmission back to the computing device.

[0032] As such, the phrase “audio module” as used throughout this specification should be understood to encompass all forms of wireless transmitter-receiver modules and not only modules specifically intended for audio applications. Similarly, the phrases “audio signal” and “audio data” should be understood to encompass any analogue voltage waveform, and any corresponding digital representation of the waveform (as a waveform data vector), respectively, as applicable to electrochemical analyses.

[0033] In one embodiment the instructions, when executed by the microprocessor, cause the audio module to generate the output voltage waveform in which the voltammetric driving potential is a triangular wave.

[0034] In some embodiments the resistor has a value in the range  $47 \Omega$  to  $4.7 \text{ k}\Omega$ , more particularly in the range  $68 \Omega$  to  $390 \Omega$ , and more particularly around  $100 \Omega$ .

[0035] In some embodiments the frequency of the AC perturbation is in the range 20 Hz to 500 Hz, more particularly in the range 100 Hz to 400 Hz, and more particularly in the range of around 200 Hz to around 300 Hz.

[0036] In some embodiments the amplitude of the AC perturbation, relative to a peak output voltage, is in the range 0.7 percent to 7 percent, and more particularly around 3 percent to around 5 percent.

[0037] In an example application the electrochemical sensor includes a photodetector placed within a detection zone of a working electrode to capture photons produced at the working electrode when the output voltage waveform is applied to the working electrode. In these embodiments the photodetector is connected to the audio signal input of the audio module such that the input voltage waveform represents an intensity of light emitted from the detection zone, whereby a corresponding concentration of the analyte may be computed based

upon the intensity of the emitted light. The photodetector may comprise a photodiode or a phototransistor.

[0038] In another example application the electrochemical sensor comprises a paper microfluidic layer loaded with electrochemilumescence (ECL) active molecules or a co-reactant within a detection zone. The first electrode may comprise a planar circuit layer forming a working electrode in contact with the detection zone of the paper microfluidic layer. In this application the instructions, when executed by the microprocessor, cause the computing device to analyse the input waveform data vector (which represents the input voltage waveform) to determine an intensity of light emitted from the detection zone, whereby a corresponding co-reactant or ECL active molecule concentration may be computed based upon the intensity of the emitted light.

[0039] In some embodiments the computing device comprises a display, operable under control of the microprocessor, and the program instructions may further cause the computing device to present information on the display comprising an indication of the intensity of light and/or a co-reactant or ECL active molecule concentration value, and/or the concentration of the analyte.

[0040] In some embodiments the audio signal input of the audio interface may comprise a second channel. This second channel of the audio signal input may be connected to receive a second output signal from the electrochemical sensor. In these embodiments, the instructions, when executed by the microprocessor, may cause the audio module to capture a second input voltage waveform received at the second channel of the audio signal input simultaneously with capturing the input voltage waveform received at the first channel of the audio signal input.

[0041] In some embodiments the first channel of the audio signal input may be configured to capture a voltammetric response waveform from the electrochemical sensor and the second channel of the audio signal input may be

configured to capture an output from a photodetector of the electrochemical sensor.

[0042] In some embodiments the computing device may further comprise a second wireless communication interface, and the program instructions may further cause the computing device to transmit information to a remote server via the second wireless communication interface, including information indicative of the concentration of the analyte.

[0043] In some embodiments the predetermined excitation waveform, and thus the output waveform data vector and the corresponding output voltage waveform, are based on user-entered electrochemical parameters.

[0044] Other optional features of the system will become apparent from a reading of the following detailed description of preferred embodiments.

## BRIEF DESCRIPTION OF THE DRAWINGS

[0045] Embodiments of the invention will be described with reference to the accompanying drawings, in which like reference numerals refer to like features, and wherein:

[0046] Figure 1 illustrates a conventional potentiostat configuration in which a computer running a simple graphical user interface (GUI) is used to control a remotely attached dedicated hardware potentiostat;

[0047] Figure 2 illustrates a prior art “software potentiostat” running on a mobile computing device, such as a tablet or smartphone, making use of the device’s inbuilt audio hardware;

[0048] Figure 3 illustrates a preferred embodiment of the present invention in which a software potentiostat is implemented on a mobile computing device with an attached Bluetooth or other wireless audio module;

[0049] Figure 3A illustrates an alternative embodiment of the invention in which a software potentiostat is implemented on a mobile computing device with an attached Bluetooth or other wireless audio module;

[0050] Figure 4 illustrates an alternative embodiment of the invention in which a Bluetooth audio module is packaged with a screen printed electrode holder;

[0051] Figure 5 illustrates a dual opto-electrochemical embodiment of the invention using a photo diode; and

[0052] Figure 6 illustrates a dual working electrode current measurement embodiment of the invention.

## DESCRIPTION OF PREFERRED EMBODIMENTS

[0053] Reference will now be made in detail to exemplary embodiments of the invention. It is to be understood that the detailed examples and embodiments described herein are given by way of example for illustrative purposes only, and are in no way considered to be limiting to the invention.

[0054] It must also be noted that, as used in the specification and the appended claims, the singular forms 'a', 'an' and 'the' include plural referents unless otherwise specified. Thus, for example, reference to 'analyte' may include more than one analyte, and the like.

[0055] Throughout this specification, use of the terms 'comprises' or 'comprising' or grammatical variations thereon shall be taken to specify the

presence of stated features, integers, steps or components but does not preclude the presence or addition of one or more other features, integers, steps, components or groups thereof not specifically mentioned.

[0056] Referring to Figure 3 of the accompanying drawings, there is shown a block diagram of a system for sensing or measuring the concentration of an analyte in accordance with an embodiment of the present invention. The system comprises a computing device 30 having a HMI/GUI 32, a microprocessor and one or more memory components 34 containing a program and data store accessible to the microprocessor. A bidirectional wireless Bluetooth communication interface 35 serves to stream “audio” data to and from a separate Bluetooth-enabled audio module 36.

[0057] The audio module 36 comprises an audio signal output 37 having first and second channels (Rout, Lout) and an audio signal input (Mic in).

[0058] Analogous to the arrangement shown in Figure 2, user-entered data is used to control a software potentiostat implemented within the computing device 30. The computing device 30 converts electrochemical parameters 39 to a calculated waveform data vector.

[0059] In use, the audio module 36 is connectable to an electrochemical sensor in the form of a voltammetric cell 38, with the first and second channels (Rout, Lout) of the audio signal output 37 being connected to first and second electrodes of the voltammetric cell 38. The audio signal input (Mic in) is connected to receive an output signal from the voltammetric cell 38.

[0060] The program and data store within the memory 34 contains instructions which, when executed by the microprocessor, cause the system to implement a number of steps as follows. Firstly, the computing device 30 calculates at least one output waveform data vector, and in this two channel “stereo” embodiment, first and second output waveform data vectors

corresponding to the first and second channel. Together these output waveform data vectors represent a desired excitation waveform (based on the user entered electrochemical parameters 39). The computing device 30 transmits the output waveform data vectors to the audio module 36 and the audio module then generates an output voltage waveform, corresponding to the output waveform data vectors, between the first and second channels (Rout, Lout) of the audio signal output 37. Simultaneously with generating the output voltage waveform, the audio module 36 captures an input voltage waveform received at the audio signal input (Mic in) and converts the input voltage waveform to an input waveform data vector. The audio module 36 transmits the input waveform data vector to the computing device 30 and the computing device then records the input waveform data vector, within the data store 34, as a response waveform indicative of the concentration of the analyte.

[0061] The concentration of the analyte may then be presented on the data display of the HMI/GUI 32 and/or be transmitted to a remote computer or server on an associated computer network.

[0062] In substance, the novel configuration shown in Figure 3 is similar to the prior art “soft potentiostat” described in WO 2017/156584 referred to above, and shown in Figure 2, but the output/input waveform data vectors of the “soft potentiostat” are wirelessly streamed to/from (respectively) an external audio module.

[0063] Surprisingly, the use of conventional wireless audio modules allows efficient streaming of electrochemical data to and from a computing device such as a mobile phone, enabling un-wired instrument-free electrochemical analysis. The inventors have found that 16 bit data resolution at a sampling frequency of 8kHz is sufficient for most electrochemical analytical purposes but other resolutions and sampling rates, higher or lower, could instead be used. For example, CD quality digital audio data is normally published at 16 bit resolution

and a sampling frequency of 44.1 kHz, so wireless audio modules of this type are very commonly available at low cost.

[0064] In the embodiment shown in Figure 3, the digital audio stream may be transmitted to a common, off-the-shelf “Bluetooth audio adapter” module. This arrangement is similar to that disclosed in WO 2017/156584, and shown in Figure 2, in that the audio adapter/module 36 (in Figure 3) can be connected to an electrochemical cell 38 with a simple resistor R and capacitor C, as in Figure 2. The microphone input (Mic in) of this wireless audio adapter 36 is connected to the voltammetric cell 38 as before. The microphone “audio” stream is passed to the “soft potentiostat” implemented within the computing device 30, which interprets it as an electrochemical current.

[0065] In one example implementation, consistent with the method described in WO 2017/156584, an output voltage waveform is generated (under software control) between the first and second channels (Rout, Lout) of the audio signal output 37 of a suitable audio adapter 36. The output voltage waveform comprises a time-varying voltammetric driving potential (such as a ramp or triangular wave) combined with an AC perturbation signal. More particularly, the mobile computing device 30 may be programmed to generate a first waveform for output on the first channel and a second waveform for output on the second channel, where the first and second waveforms are inverse to one another, such that the total potential available to be applied between the first and second channel outputs is effectively double the peak voltage output available at each channel individually. Furthermore, the AC perturbation may be superimposed on either one of the first and second waveforms. For example, the AC perturbation may be superimposed on the first waveform and applied to a counter electrode of the cell 38 directly. Alternatively, the AC perturbation may be superimposed on the second waveform, and applied to the working electrode of the voltammetric cell 38 via the resistor R. The resulting current, which flows in the circuit via the voltammetric cell 38, generates a voltage across the resistor R which has AC

components that can be received and captured by the audio signal input (Mic in) of the audio module 36 via the capacitor C.

[0066] In another example implementation, shown in Figure 3A, an audio module 36' is used in a "mono" mode of operation rather than in a "stereo" mode. In this mono mode, only a single output channel is used, rather than two output channels as in Figure 3.

[0067] Referring to Figure 3A, the audio module 36' comprises an audio signal output 37' having an output channel (OUT) and an audio signal input (Mic in). All other components shown in Figure 3A are similar to those shown in Figure 3 so corresponding reference numerals (30', 32', etc) are used to denote corresponding components.

[0068] In the Figure 3A implementation, an output voltage waveform is generated (under software control) between the output channel (OUT) and common ground reference (GND) of the audio adapter 36'. Again, the output voltage waveform comprises a time-varying voltammetric driving potential (such as a ramp or triangular wave) combined with an AC perturbation signal. More particularly, the mobile computing device 30' may be programmed to generate a waveform for output on the output channel (OUT) together with an AC perturbation superimposed on the waveform. The resulting current, which flows in the circuit via the voltammetric cell 38', generates a voltage across the resistor R which has AC components that can be received and captured by the audio signal input (Mic in) of the audio module 36' via the capacitor C.

[0069] In other embodiments, of either "stereo" or "mono" implementations, alternative output voltage waveforms may be generated as excitation signals for output to a voltammetric cell, or for application to other forms of electrochemical sensors. The selection and implementation of alternative output voltage waveforms is considered to be well within the skill of persons skilled in the art of electrochemical methods and will not be described herein in detail.

[0070] The novel configurations shown in Figures 3 and 3A overcome many of the limitations of the software potentiostat shown in Figure 2 (and disclosed in WO 2017/156584) with considerably less complexity and expense.

[0071] Some of the other benefits of the new configurations include but are not limited to:

- Even computing devices without built-in audio capability can be utilised to facilitate electrochemical measurements.
- Computing devices with Bluetooth, or similar wireless connectivity, capable of running the HMI/GUI and “soft potentiostat” can be extended to, but are not limited to, smartphones, tablets, PCs, laptops, single board computers (Raspberry Pi, etc) and smart watches.
- The DC blocking capacitor which is found in the audio output circuitry of many phones and tablets represents a limitation on the types of electrochemical measurements possible with the configuration of Figure 2. The configuration of Figures 3 and 3A overcome this limitation because an appropriate off-the-shelf wireless audio adapter can be chosen without such components.
- Easier and more reproducible standardisation and calibration is facilitated making the resulting electrochemical analysis more accurate as only the Bluetooth audio module needs to be considered.
- The configurations of Figures 3 and 3A are especially suited for use in conjunction with disposable printed electrochemical sensors, but may also be used with conventional electrodes.

[0072] Some of the useful types of measurements possible utilising the configurations shown in Figures 3 or 3A include:

- AC voltammetry
- 2nd harmonic FT AC voltammetry
- Square wave voltammetry
- Most pulsed voltammetric techniques

- Impedance and impedance spectroscopy

[0073] Another limitation associated with the configuration of Figure 2 is the limited voltage range available from the audio output of some smartphones and tablets. This is not a problem for the configuration of Figure 3 because a suitable wireless audio adapter can be chosen such that this is not an issue. In other words, an appropriate off-the-shelf Bluetooth audio adapter can be chosen, rather than being forced to choose an appropriate smartphone.

[0074] In the latter regard, the voltage range available from smartphones and tablets seems to vary quite widely between phones, and also depends on whether the phone has been “rooted” – this being a process which allows root access to the operating system code of an Android phone (the equivalent term for Apple is “jailbreaking”). Some examples of voltage ranges available using commonly available smartphones are as follows:

- Rooted Galaxy S1 +/- 1.5 V
- Galaxy S3 +/- 400mV
- Galaxy TAB +/- 685 mV
- Galaxy S6 edge +/- 600 mV

[0075] Since each smartphone is different, and different users own different smartphones, consistency and repeatability of the electrochemical analysis by different users becomes problematic. Some smartphones would be suitable for some forms of analysis but other smartphones would not, for example where the voltage range available from the audio signal output is insufficient.

[0076] As discussed in WO 2017/156584, the use of the left and right audio outputs simultaneously, effectively doubles the voltage range available for electrochemical stimulation of the test solution. For aqueous media, a range of +/- 1 V covers the requirements for the majority of electrochemical analyses. The configuration of Figure 3 enables selection of an appropriate Bluetooth audio

module which satisfies the necessary voltage range, without needing to consider the output voltage range of the smartphone being used.

[0077] In addition, the inventors have found that some Bluetooth audio modules are capable of producing an output voltage which is higher than that available from the audio output of a typical smartphone. Accordingly, selection of a suitable Bluetooth (or other wireless) audio module may enable a “mono” mode of operation, as described above, with sufficient voltage range for the desired electrochemical analyses.

[0078] One example of an off-the-shelf Bluetooth audio adapter which the inventors have found to be suitable for use in the configuration of Figure 3 is the “Wireless Bluetooth V4.1 3.5mm AUX Audio Stereo Music Home Car Receiver Adapter” sold by Home Outlet.

[0079] Other examples of suitable Bluetooth audio adapters/modules include devices based on the following Bluetooth modules:

- RN52 produced by Microchip Technology Inc.
- XS3868 produced by 14CORE
- CSR 8643 produced by Qualcomm
- OVC3860 produced by 14CORE
- BK8000L available from Electrodragon

[0080] These are all “naked” (without an external casing) highly integrated single chip Bluetooth stereo audio modules which support the mandatory Bluetooth compression coding/decoding (CODEC) scheme, Sub Band Coding (SBC), and/or support more advanced audio CODECs used for hi-fi stereo audio, such as Advanced Audio Distribution Profile (A2DP), aptX by Qualcomm or LDAC by Sony.

[0081] Because wireless audio adapters and the Bluetooth modules they contain, are already being mass-produced for conventional applications such as

audio streaming and telephony, repurposing such devices for voltammetric or other electrochemical analysis represents a very low cost option compared to the use of conventional electrochemical instrumentation. In turn this facilitates a range of electroanalytical measurements outside of a laboratory setting, e.g. in the field, at the point-of-care, at home, etc. Furthermore, the significant decrease in hardware costs and increase in portability, allows measurements in resource-poor environments as well as remote areas.

[0082] It is also contemplated that more general purpose wireless transmitter-receiver communications modules could be used, rather than repurposing off-the-shelf Bluetooth audio adapters. In this regard, the data streamed between the audio module 36/36' and computing device 30, shown in Figures 3 and 3A, is not audio data as such but a waveform data vector representing a required excitation waveform. Accordingly, the phrase "audio module" must be understood broadly to include any sort of wireless transmitter-receiver communications module capable of bidirectional transmission and reception of data representing analogue voltage waveforms.

[0083] Off-the-shelf Bluetooth audio adapters, such as those mentioned above, or customized wireless transmitter-receiver modules, can also be easily co-packaged with the necessary RC interface circuit and cell connection socket for voltammetric measurements as shown in Figure 3 or 3A.

[0084] One example of such a co-packaged audio adapter and screen printed electrode holder is shown in Figure 4. In this embodiment the co-packaged circuit includes a Bluetooth module 40 such as the RN52, a small lithium battery 42, power switch 44, one resistor R, one capacitor C and the screen printed electrode holder/connector 46. Rout and Lout are the right and left audio output channels of the Bluetooth module 40, and likewise Rin and Lin are the right and left audio input channels to the audio module 40. In this example a single input voltage waveform from the electrode holder 46 is connected to both the audio input channels, Rin and Lin. The audio input channels may be amplified inside the

Bluetooth module 40 by selecting them to be “mic” inputs rather than “line level” inputs. This is typically done as part of the Bluetooth module configuration and provides more sensitivity to the electrochemical measurement. The screen printed electrode holder 46 may have two, three or more connections. For the packaging arrangement shown in Figure 4 only two connections are required, namely the Reference electrode 47 (aka Counter electrode) and the Working electrode 48. This circuit could be physically packaged in a small plastic moulded shell of approximate dimensions 50mm x 20mm x 10mm

[0085] As many off-the-shelf Bluetooth audio adapters have independent left and right microphone/audio input channels, the configuration in Figure 3 can be extended to include simultaneous measurement of a second waveform. For example, if a photodetector, such as a photodiode or phototransistor, is attached to one of the microphone input channels as shown in Figure 5, a further class of measurements can be made, namely Electrochemiluminescence, aka “electrogenerated chemiluminescence” (ECL), or analytical spectroelectrochemical detection.

[0086] Some examples of the types of electrochemical measurements which could be made based on ECL techniques are described in the Australian innovation patent AU2014100086 referred to above and incorporated herein by cross-reference.

[0087] However, in the present instance, rather than using a camera integrated into a mobile phone to acquire images of the detection zone of the electrochemical sensor, a simple photodetector connected to a microphone input channel of the audio module is used instead. This extends the advantages of the configuration shown in Figure 3 to include a much broader range of electrochemical analysis techniques.

[0088] For photoelectrochemical measurements (especially electrochemiluminescence, ECL) the inclusion of a photodiode 51 is shown in

Figure 5. Other components of this circuit (Bluetooth module 50, battery 52, power switch 54, electrode holder/connector 56) are the same as those shown in Figure 4 so similar reference numerals are used. However, this embodiment makes use of the independent and simultaneous sampling of the left and right audio input channels Lin and Rin of the Bluetooth module 50, thereby facilitating simultaneous monitoring of current at the right audio signal input channel, Rin, and an associated optical signal at the left audio signal input channel, Lin. By configuring the Bluetooth audio inputs as “mic” inputs, a DC bias is provided to the photodiode 51. This, in conjunction with the amplification associated with a “mic” input, improves the sensitivity of the photoelectrochemical measurement. The physical packaging of this embodiment would ensure the photodiode was placed very close to the working electrode to maximize the capture of produced photons.

[0089] While the dual input circuit configuration shown in Figure 5 facilitates simultaneous monitoring of both current and an associated optical signal from the photodiode 51, it will be appreciated that a single audio signal input arrangement could be used to monitor only an optical signal produced by a photodiode without also monitoring current. Such an arrangement would be similar to that shown in Figure 5 but with the right audio signal input Rin omitted.

[0090] Other embodiments making use of independent left and right microphone/audio input channels could include two simultaneous working electrode measurements for internal calibration or multiplexing purposes.

[0091] One example of a dual working electrode current measurement embodiment is shown in Figure 6. The independent use of the left and right audio input channels can also be extended to simultaneous measurement of two electrochemical currents from two working electrodes 68 and 69 as shown in Figure 6. Other than the inclusion of an additional resistor R and capacitor C (as shown) the physical packaging of this embodiment would be the same as for the basic version described above with reference to Figure 4. Accordingly, similar

reference numerals are used to denote corresponding circuit features and need not be described in further detail.

[0092] Those skilled in the art will recognise, or be able to ascertain using no more than routine experimentation, many equivalents to the specific embodiments of the invention described herein. Such equivalents are intended to be encompassed by the following claims.

## CLAIMS:

1. A system for sensing or measuring the concentration of an analyte, the system in use being connectable to an electrochemical sensor, with the system comprising:

a computing device comprising a microprocessor, one or more memory components containing a program and data store accessible to the microprocessor, and a wireless communication interface; and

an audio module, wirelessly connectable to the computing device via the wireless communication interface and being operable to stream audio data between the audio module and the computing device,

the audio module comprising an audio signal output and an audio signal input,

the audio module being connectable to the electrochemical sensor with the audio signal output being connected to an electrode of the electrochemical sensor and the audio signal input being connected to receive an output signal from the electrochemical sensor, and

the program and data store containing instructions which, when executed by the microprocessor, cause the system to implement steps of:

the computing device calculating an output waveform data vector representing a desired excitation waveform;

the computing device transmitting the output waveform data vector to the audio module;

the audio module generating an output voltage waveform at the audio signal output, with the output voltage waveform being defined by the output waveform data vector;

simultaneously with generating the output voltage waveform, the audio module capturing an input voltage waveform received at the audio signal input and converting the input voltage waveform to an input waveform data vector;

the audio module transmitting the input waveform data vector to the computing device; and

the computing device recording within the data store the input waveform data vector as a response waveform indicative of the concentration of the analyte.

2. The system of claim 1 wherein the audio signal output of the audio module comprises an output channel and a common ground reference, the audio module in use being connectable to the electrochemical sensor with the output channel and common ground reference being connected to first and second electrodes of the electrochemical sensor, and wherein the output voltage waveform is generated between the output channel and the common ground reference.

3. The system of claim 2 wherein the electrochemical sensor comprises a voltammetric cell comprising said first and second electrodes,

wherein the system further comprises a circuit configuration comprising a resistor and capacitor for connecting the audio module to the voltammetric cell, with the output channel of the audio signal output being connected to the first electrode, the common ground reference of the audio signal output being connected to the second electrode via the resistor, and the audio signal input being connected to the second electrode via the capacitor,

wherein the output voltage waveform comprises a time-varying voltammetric driving potential and an AC perturbation, and

wherein the response waveform is indicative of a voltammetric response from the voltammetric cell.

4. A system for sensing or measuring the concentration of an analyte, the system in use being connectable to an electrochemical sensor, with the system comprising:

a computing device comprising a microprocessor, one or more memory components containing a program and data store accessible to the microprocessor, and a wireless communication interface; and

an audio module, wirelessly connectable to the computing device via the wireless communication interface and being operable to stream audio data between the audio module and the computing device,

the audio module comprising an audio signal output having first and second channels and an audio signal input,

the audio module being connectable to the electrochemical sensor with the first and second channels of the audio signal output being connected to first and second electrodes of the electrochemical sensor and the audio signal input being connected to receive an output signal from the electrochemical sensor, and

the program and data store containing instructions which, when executed by the microprocessor, cause the system to implement steps of:

the computing device calculating first and second output waveform data vectors together representing a desired excitation waveform;

the computing device transmitting the first and second output waveform data vectors to the audio module;

the audio module generating an output voltage waveform between the first and second channels of the audio signal output, with the output voltage waveform being defined by the first and second output waveform data vectors;

simultaneously with generating the output voltage waveform, the audio module capturing an input voltage waveform received at the audio signal input and converting the input voltage waveform to an input waveform data vector;

the audio module transmitting the input waveform data vector to the computing device; and

the computing device recording within the data store the input waveform data vector as a response waveform indicative of the concentration of the analyte.

5. The system of claim 4 wherein the electrochemical sensor comprises a voltammetric cell comprising said first and second electrodes,

wherein the system further comprises a circuit configuration comprising a resistor and capacitor for connecting the audio module to the voltammetric cell,

with the first channel of the audio signal output being connected to the first electrode, the second channel of the audio signal output being connected to the second electrode via the resistor, and the audio signal input being connected to the second electrode via the capacitor,

wherein the output voltage waveforms comprises a time-varying voltammetric driving potential and an AC perturbation, and

wherein the response waveform is indicative of a voltammetric response from the voltammetric cell.

6. The system of claim 5 wherein the instructions, when executed by the microprocessor, cause the audio module to generate the output voltage waveform by:

generating a first waveform comprising the voltammetric driving waveform;

generating a second waveform comprising an inverse of the voltammetric driving waveform;

superimposing the AC perturbation to one of the first and second waveforms; and

applying the first waveform to the first channel of the audio signal output, and the second waveform to the second channel of the audio signal output.

7. The system of any one of the preceding claims wherein an electrode of the electrochemical sensor is a working electrode and the electrochemical sensor includes a photodetector placed within a detection zone of the working electrode to capture photons produced at the working electrode when the output voltage waveform is applied to the working electrode,

and wherein in use the photodetector is connected to the audio signal input of the audio module such that the input voltage waveform represents an intensity of light emitted from the detection zone, whereby a corresponding concentration of the analyte may be computed based upon the intensity of the emitted light.

8. The system of claim 7 wherein the photodetector comprises a photodiode and the audio signal input of the audio module is configured to receive the input voltage waveform from the photodiode.

9. The system of claim 7 or claims 8 wherein the electrochemical sensor comprises a paper microfluidic layer loaded with electrochemilumescence (ECL) active molecules or a co-reactant within a detection zone, wherein the working electrode comprises a planar circuit layer in contact with the detection zone of the paper microfluidic layer, and wherein the instructions, when executed by the microprocessor, cause the computing device to implement a step of:

analysing the input waveform data vector, representing the input voltage waveform, to determine an intensity of light emitted from the detection zone, whereby a corresponding co-reactant or ECL active molecule concentration may be computed based upon the intensity of the emitted light.

10. A system according to claim 9 wherein the computing device comprises a display operable under control of the microprocessor, and wherein the program instructions further cause the computing device to implement a step of:

presenting information on the display comprising an indication of the intensity of light and/or a co-reactant or ECL active molecule concentration value.

11. The system of any one of the preceding claims wherein the audio signal input of the audio interface comprises a first channel and a second channel, the second channel of the audio signal input being connected to receive a second output signal from the electrochemical sensor,

and wherein the instructions, when executed by the microprocessor, cause the audio module to capture a second input voltage waveform received at the second channel of the audio signal input simultaneously with capturing an input voltage waveform received at the first channel of the audio signal input.

12. The system of claim 11 wherein the first channel of the audio signal input is configured to capture a voltammetric response waveform from the

electrochemical sensor and the second channel of the audio signal input is configured to capture an output from a photodetector of the electrochemical sensor.

13. The system of any one of the preceding claims wherein the computing device is a mobile computing device such as a smartphone, tablet or laptop computer.

14. The system of any one of the preceding claims wherein the wireless communication interface is a Bluetooth interface and communication between the audio module and the computing device involves streaming of data using a Bluetooth audio encoding method.

15. The system of any one of the preceding claims wherein the computing device further comprises a second wireless communication interface, and wherein the program instructions further cause the computing device to implement a step of:

transmitting information to a remote server via the second wireless communication interface, including information indicative of the concentration of the analyte.

**LA TROBE UNIVERSITY**

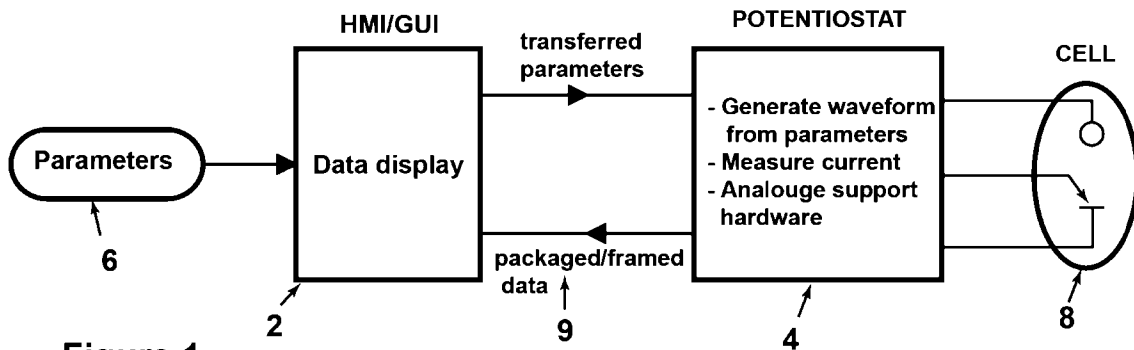

Figure 1

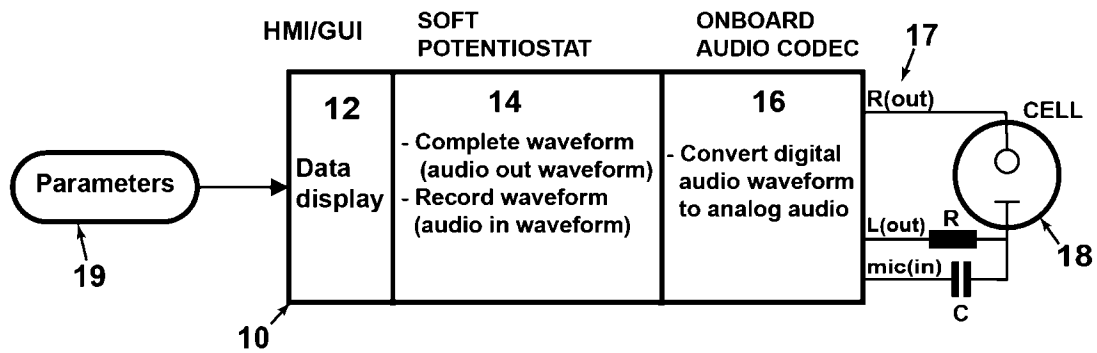

Figure 2

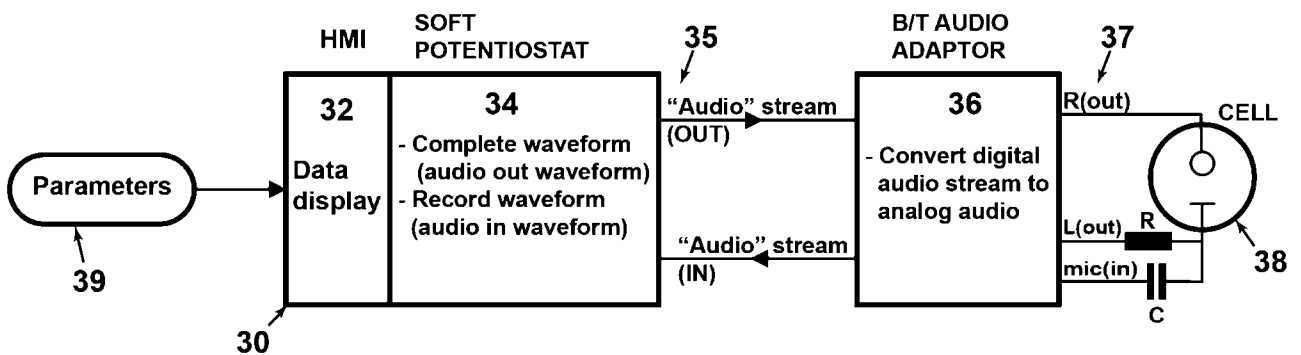

Figure 3

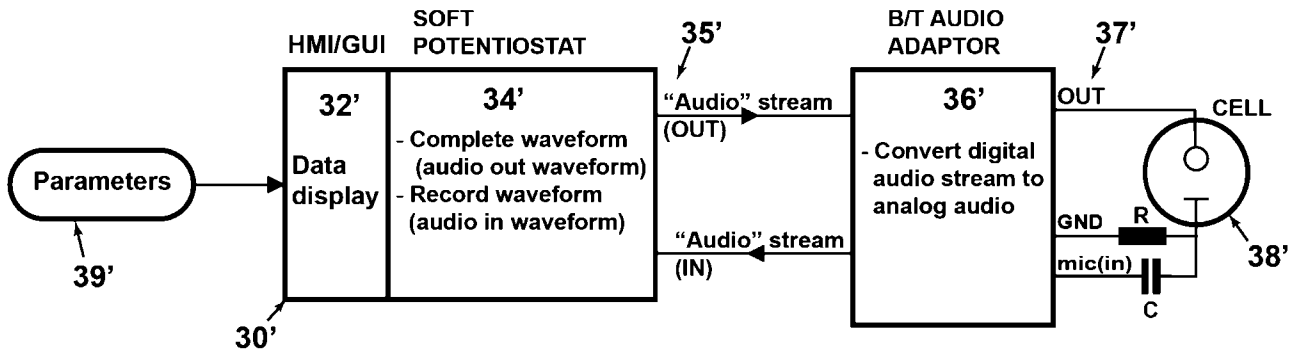

Figure 3A

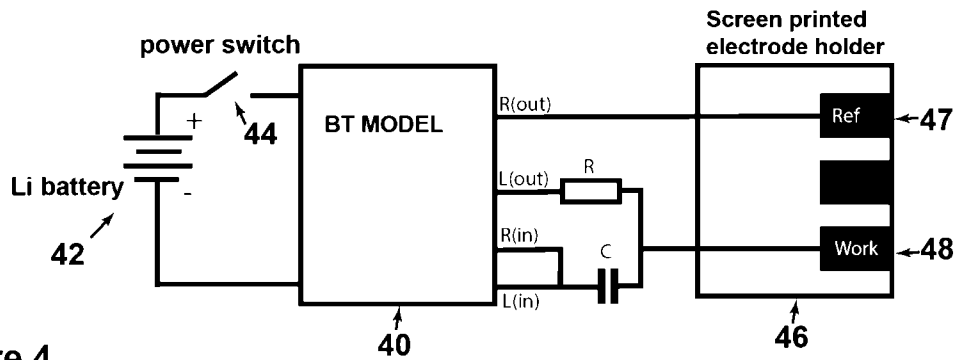

Figure 4

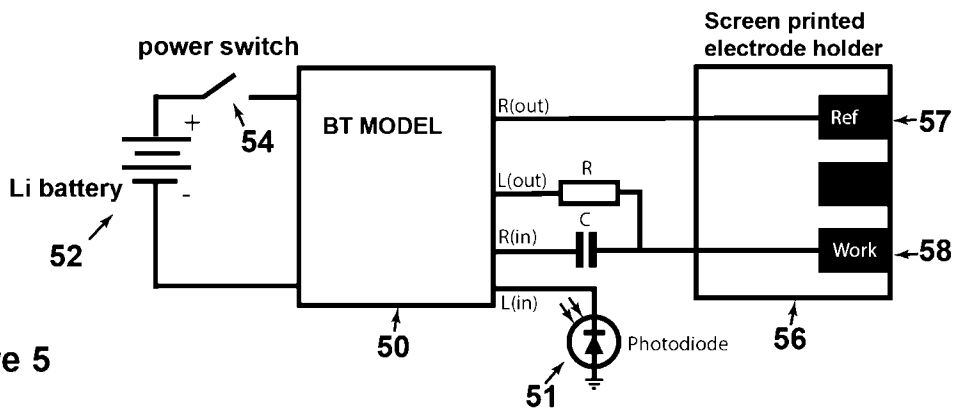

Figure 5

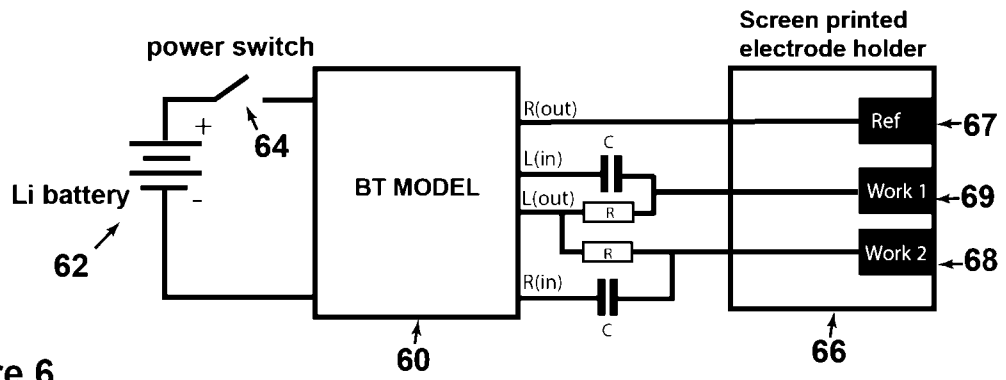

Figure 6

**A. CLASSIFICATION OF SUBJECT MATTER****G08C 17/02(2006.01)i, G06F 3/16(2006.01)i**

According to International Patent Classification (IPC) or to both national classification and IPC

**B. FIELDS SEARCHED**

Minimum documentation searched (classification system followed by classification symbols)

G08C 17/02; A61B 5/00; A61B 5/024; A61B 5/0402; A61B 5/1455; A61B 6/00; G01N 27/327; G06K 9/00; G10L 19/008; G06F 3/16

Documentation searched other than minimum documentation to the extent that such documents are included in the fields searched

Korean utility models and applications for utility models

Japanese utility models and applications for utility models

Electronic data base consulted during the international search (name of data base and, where practicable, search terms used)

eKOMPASS(KIPO internal) &amp; Keywords: analysis, waveform, voltage, sensor, signal

**C. DOCUMENTS CONSIDERED TO BE RELEVANT**

| Category* | Citation of document, with indication, where appropriate, of the relevant passages                                | Relevant to claim No. |
|-----------|---|-----------------------|
| X         | US 2019-0072513 A1 (LA TROBE UNIVERSITY) 07 March 2019<br>paragraphs [0047]-[0074]; claim 1; and figure 3A        | 1-6                   |
| Y         |   | 7,8                   |
| Y         | US 2014-0073965 A1 (PIROW ENGELBRECHT et al.) 13 March 2014<br>claim 1; and figure 2                              | 7,8                   |
| A         | US 2016-0361004 A1 (CHRONISENSE MEDICAL LTD.) 15 December 2016<br>paragraphs [0045]-[0048]; claim 1; and figure 1 | 1-8                   |
| A         | US 2015-0366492 A1 (KONINKLIJKE PHILIPS N.V.) 24 December 2015<br>paragraphs [0056]-[0060]; claim 1; and figure 1 | 1-8                   |
| A         | KR 10-2007-0085856 A (IDESIA LTD.) 27 August 2007<br>paragraphs [0069]-[0169]; claim 1; and figure 18             | 1-8                   |

 Further documents are listed in the continuation of Box C. See patent family annex.

\* Special categories of cited documents:

"A" document defining the general state of the art which is not considered to be of particular relevance

"D" document cited by the applicant in the international application

"E" earlier application or patent but published on or after the international filing date

"L" document which may throw doubts on priority claim(s) or which is cited to establish the publication date of another citation or other special reason (as specified)

"O" document referring to an oral disclosure, use, exhibition or other means

"P" document published prior to the international filing date but later than the priority date claimed

"T" later document published after the international filing date or priority date and not in conflict with the application but cited to understand the principle or theory underlying the invention

"X" document of particular relevance; the claimed invention cannot be considered novel or cannot be considered to involve an inventive step when the document is taken alone

"Y" document of particular relevance; the claimed invention cannot be considered to involve an inventive step when the document is combined with one or more other such documents, such combination being obvious to a person skilled in the art

"&amp;" document member of the same patent family

Date of the actual completion of the international search

23 September 2020 (23.09.2020)

Date of mailing of the international search report

**23 September 2020 (23.09.2020)**

Name and mailing address of the ISA/KR

International Application Division

Korean Intellectual Property Office

189 Cheongsa-ro, Seo-gu, Daejeon, 35208, Republic of Korea



Facsimile No. +82-42-481-8578

Authorized officer

JANG, Gijeong

Telephone No. +82-42-481-8364





**INTERNATIONAL SEARCH REPORT**

Information on patent family members

International application No.

**PCT/AU2020/050524**

| Patent document cited in search report | Publication date | Patent family member(s)  | Publication date   |
|--|------------------|--|--|
| US 2019-0072513 A1                     | 07/03/2019       | AU 2017-234382 A1<br>CN 109073589 A<br>EP 3430386 A1<br>JP 2019-509490 A<br>WO 2017-156584 A1  | 20/09/2018<br>21/12/2018<br>23/01/2019<br>04/04/2019<br>21/09/2017   |
| US 2014-0073965 A1                     | 13/03/2014       | None   |  |
| US 2016-0361004 A1                     | 15/12/2016       | CN 107920786 A<br>EP 3307146 A1<br>EP 3307150 A1<br>EP 3307162 A1<br>EP 3493734 A1<br>US 10470692 B2<br>US 10687742 B2<br>US 2016-0360971 A1<br>US 2016-0360974 A1<br>US 2016-0360986 A1<br>US 2016-0361003 A1<br>US 2018-0132794 A1<br>US 2019-0015014 A1<br>WO 2016-199121 A1<br>WO 2016-199122 A1<br>WO 2016-199123 A1<br>WO 2016-199124 A1<br>WO 2018-025257 A1<br>WO 2019-130296 A1 | 17/04/2018<br>18/04/2018<br>18/04/2018<br>18/04/2018<br>12/06/2019<br>12/11/2019<br>23/06/2020<br>15/12/2016<br>15/12/2016<br>15/12/2016<br>15/12/2016<br>17/05/2018<br>17/01/2019<br>15/12/2016<br>15/12/2016<br>15/12/2016<br>15/12/2016<br>08/02/2018<br>04/07/2019 |
| US 2015-0366492 A1                     | 24/12/2015       | CN 106456071 A<br>EP 3157431 A1<br>JP 2017-522953 A<br>JP 6336141 B2<br>US 9924896 B2<br>WO 2015-197383 A1   | 22/02/2017<br>26/04/2017<br>17/08/2017<br>06/06/2018<br>27/03/2018<br>30/12/2015   |
| KR 10-2007-0085856 A                   | 27/08/2007       | AU 2003-256693 A1<br>AU 2003-256693 B2<br>AU 2004-324705 A1<br>AU 2005-310994 A1<br>AU 2010-246527 A1<br>CA 02494491 A1<br>CA 02586772 A1<br>CA 02587214 A1<br>CA 2494491 C<br>CA 2586772 C<br>CN 101263510 A<br>CN 101421744 A<br>CN 101421744 B<br>CN 1672357 A  | 16/02/2004<br>01/05/2008<br>11/05/2006<br>08/06/2006<br>23/12/2010<br>05/02/2004<br>08/06/2006<br>11/05/2006<br>02/11/2010<br>13/01/2015<br>10/09/2008<br>29/04/2009<br>05/06/2013<br>21/09/2005   |

**INTERNATIONAL SEARCH REPORT**

Information on patent family members

International application No.

**PCT/AU2020/050524**

| Patent document<br>cited in search report | Publication<br>date | Patent family<br>member(s) | Publication<br>date |
|---|---------------------|----------------------------|---------------------|
|   |                     | CN 1672357 C               | 21/09/2005          |
|   |                     | EP 1525710 A1              | 27/04/2005          |
|   |                     | EP 1815386 A1              | 08/08/2007          |
|   |                     | EP 1815391 A2              | 08/08/2007          |
|   |                     | JP 2005-534378 A           | 17/11/2005          |
|   |                     | JP 2008-518708 A           | 05/06/2008          |
|   |                     | JP 2008-518709 A           | 05/06/2008          |
|   |                     | JP 4562078 B2              | 13/10/2010          |
|   |                     | JP 4782141 B2              | 28/09/2011          |
|   |                     | KR 10-0944443 B1           | 25/02/2010          |
|   |                     | KR 10-1019838 B1           | 04/03/2011          |
|   |                     | KR 10-1019844 B1           | 04/03/2011          |
|   |                     | KR 10-2005-0079249 A       | 09/08/2005          |
|   |                     | KR 10-2007-0085857 A       | 27/08/2007          |
|   |                     | KR 10-2008-0106481 A       | 05/12/2008          |
|   |                     | KR 10-2010-0095659 A       | 31/08/2010          |
|   |                     | US 2005-0281439 A1         | 22/12/2005          |
|   |                     | US 2006-0013445 A1         | 19/01/2006          |
|   |                     | US 2006-0136744 A1         | 22/06/2006          |
|   |                     | US 7171680 B2              | 30/01/2007          |
|   |                     | US 7689833 B2              | 30/03/2010          |
|   |                     | WO 2004-012388 A1          | 05/02/2004          |
|   |                     | WO 2006-048701 A2          | 11/05/2006          |
|   |                     | WO 2006-059190 A2          | 08/06/2006          |
|   |                     | WO 2006-059190 A3          | 21/02/2008          |