

[54] **ELECTROSTATIC LOUDSPEAKER AND AMPLIFIER**

[76] Inventor: **Harold N. Beveridge**, 1616 Franceshi Rd., Santa Barbara, Calif.

[22] Filed: **June 5, 1972**

[21] Appl. No.: **259,516**

Related U.S. Application Data

[62] Division of Ser. No. 833,952, June 17, 1969, Pat. No. 3,668,335.

[52] U.S. Cl. **179/1 A, 179/1 F**

[51] Int. Cl. **H03f 1/00**

[58] Field of Search **179/1 F, 1 FS, 1 A, 179/111; 330/29, 30 D**

[56] **References Cited**

UNITED STATES PATENTS

3,047,661	7/1962	Winker.....	179/1 F
2,968,695	1/1961	Corliss.....	179/1 F
2,493,819	1/1950	Harry.....	179/1 F

Primary Examiner—Kathleen H. Claffy
Assistant Examiner—Jon Bradford Leahey
Attorney—John Noel Williams

[57] **ABSTRACT**

An electrostatic loud speaker system is shown which

combines a balanced transducer, an amplifier and an enclosure each of unique construction which together permit the reproduction of frequencies over the full audio range. The electrostatic transducer is shown surrounded by an enclosure that has an outlet passage preferably significantly smaller than the transducer and an acoustic lens preferably guides the sound through the narrow outlet into a wave form of circular cross-section. By these provisions a low resonant frequency for the speaker and wide dispersal of the directional high frequencies are achieved in an enclosure of limited size. The fixed electrodes of the transducer are of substantial thickness and are formed of high dielectric constant material, achieved preferably by molding a lower K matrix with additives raising K and lowering volumetric resistivity. The amplifier is formed of series-connected active devices, one controlled by the other. A third active device amplifies the audio signal. Its output is connected to control the first of the series-connected devices and the output terminal of the amplifier is connected through a resistive feedback path to the output of the third device. A further feedback system employs a carrier wave applied to the diaphragm of the transducer. The resulting signal on the electrodes is differentiated and negatively fed back to damp speaker response at low frequency resonance.

13 Claims, 22 Drawing Figures

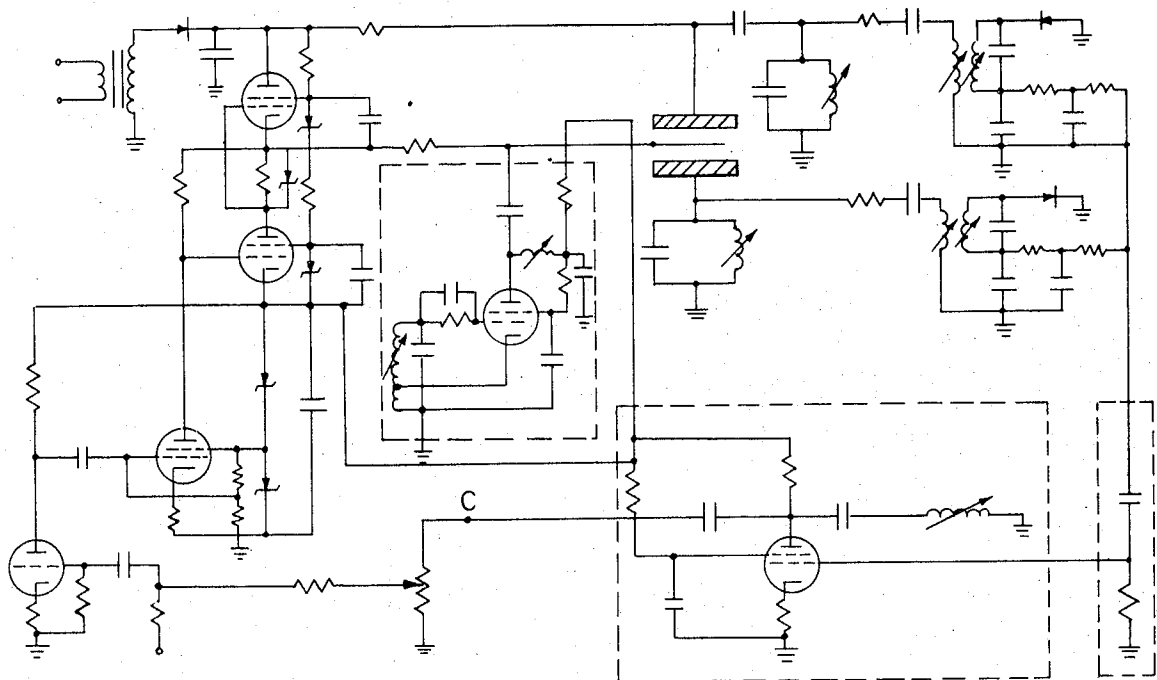
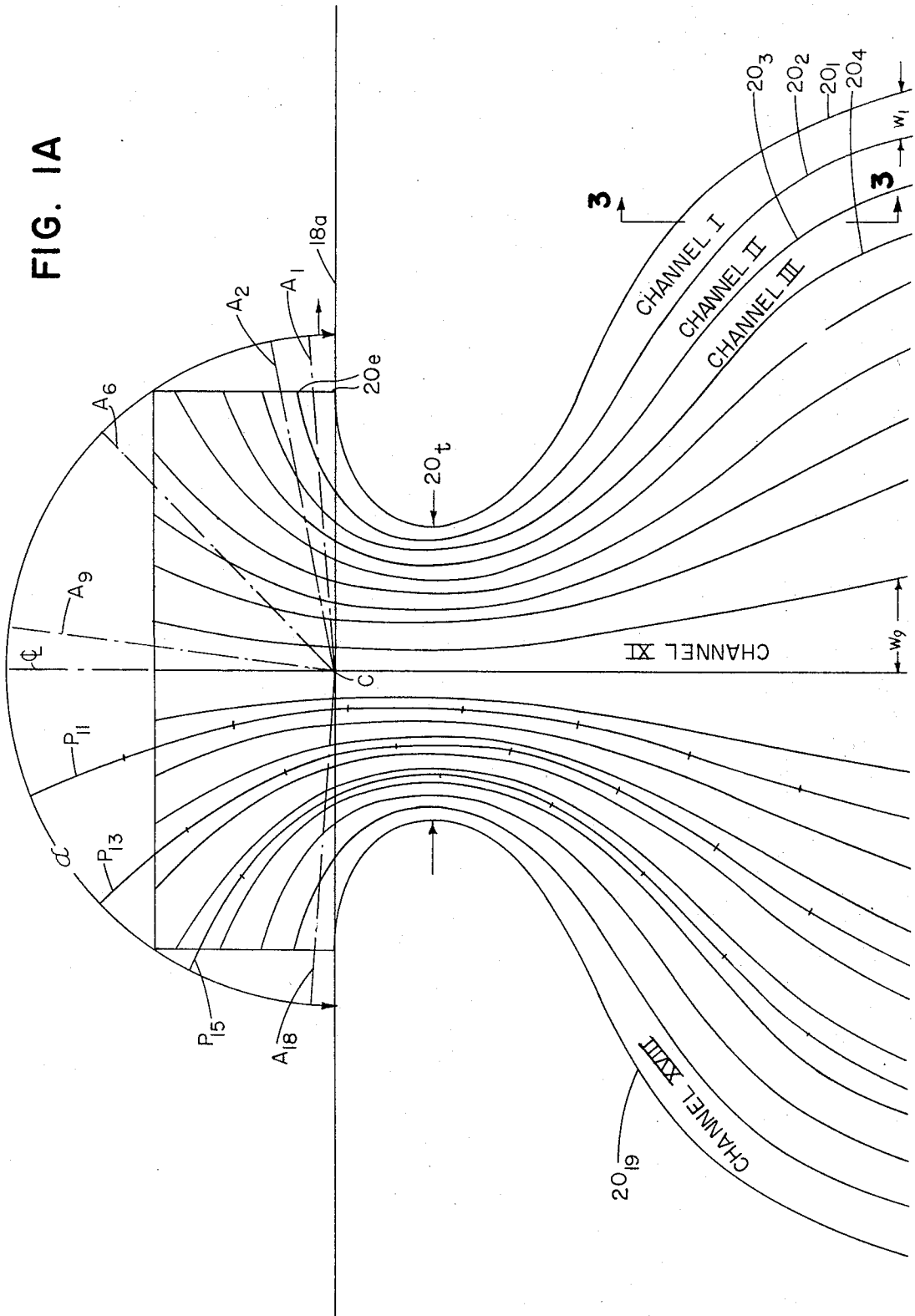

FIG. 1A



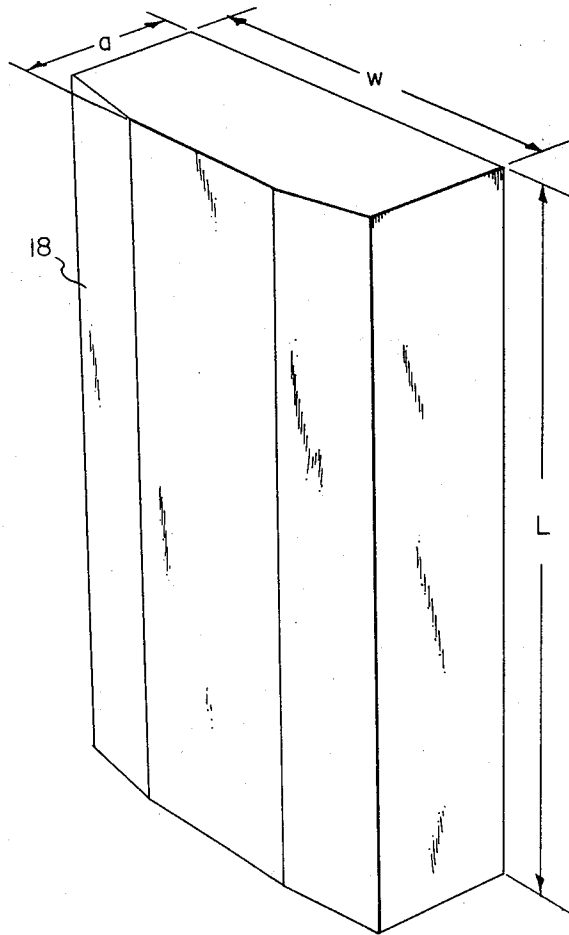

FIG. 2

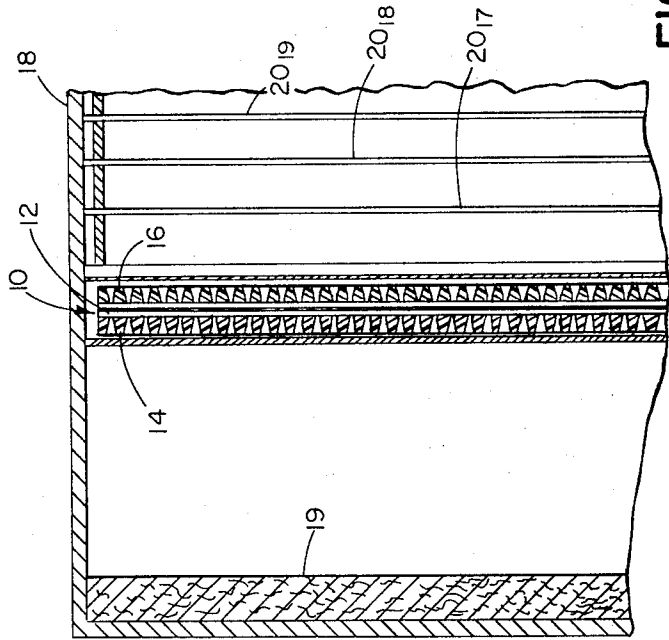

FIG. 3

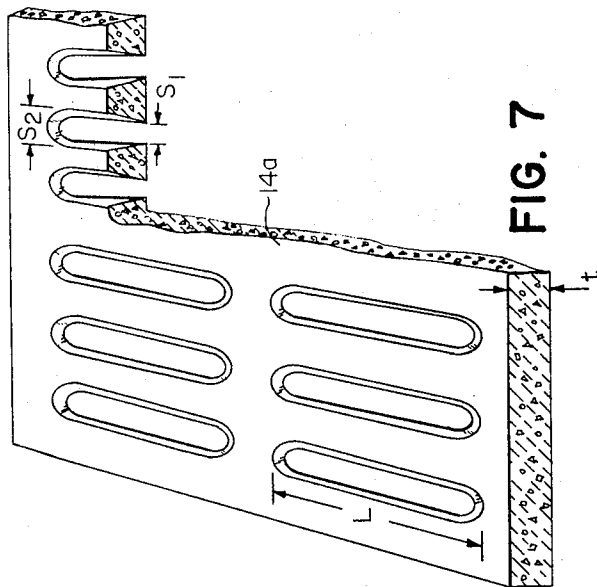

FIG. 7

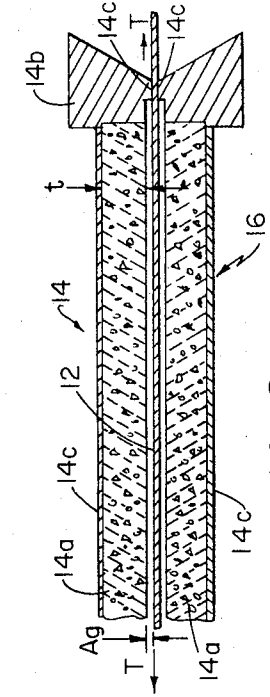

FIG. 9

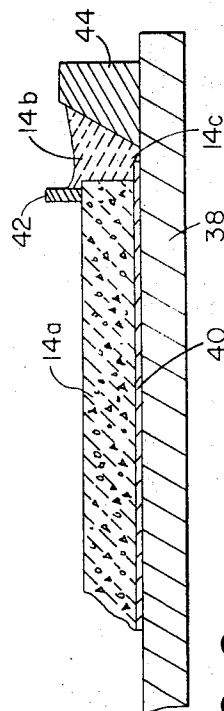

FIG. 8

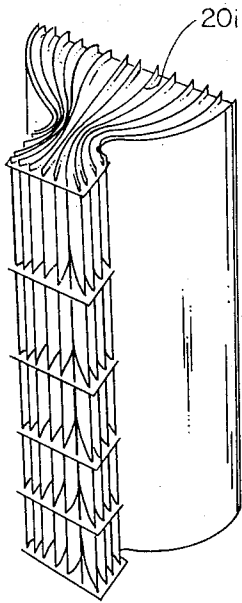

FIG. 4

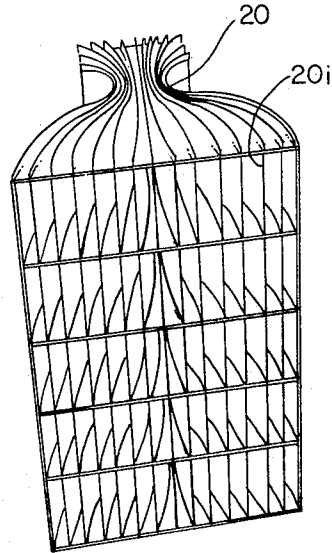

FIG. 5

FIG. 6a

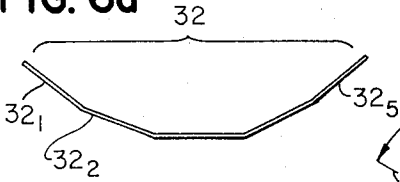
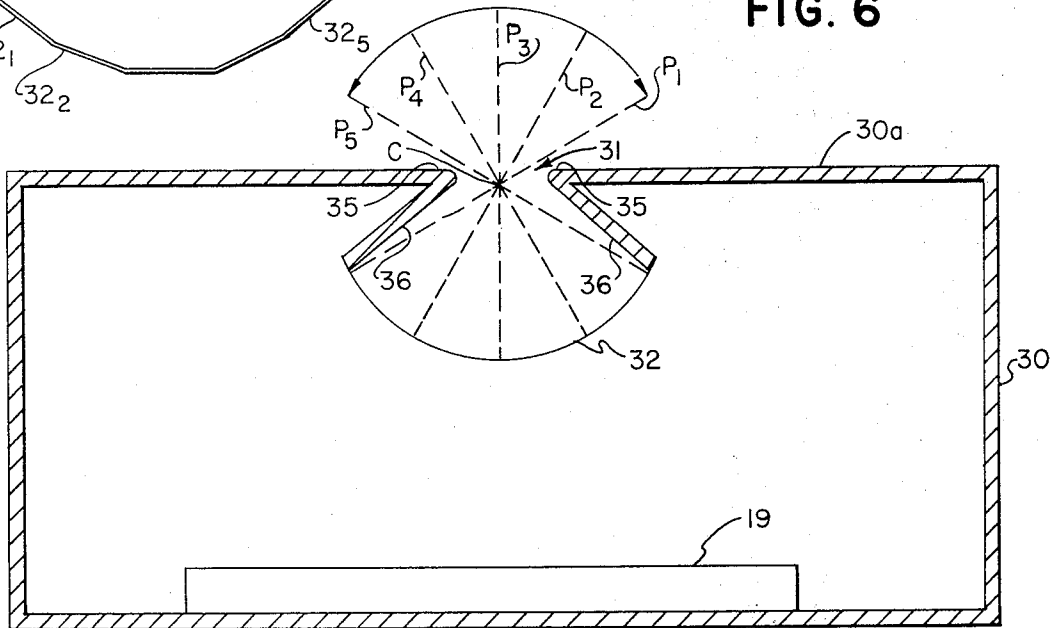

FIG. 6



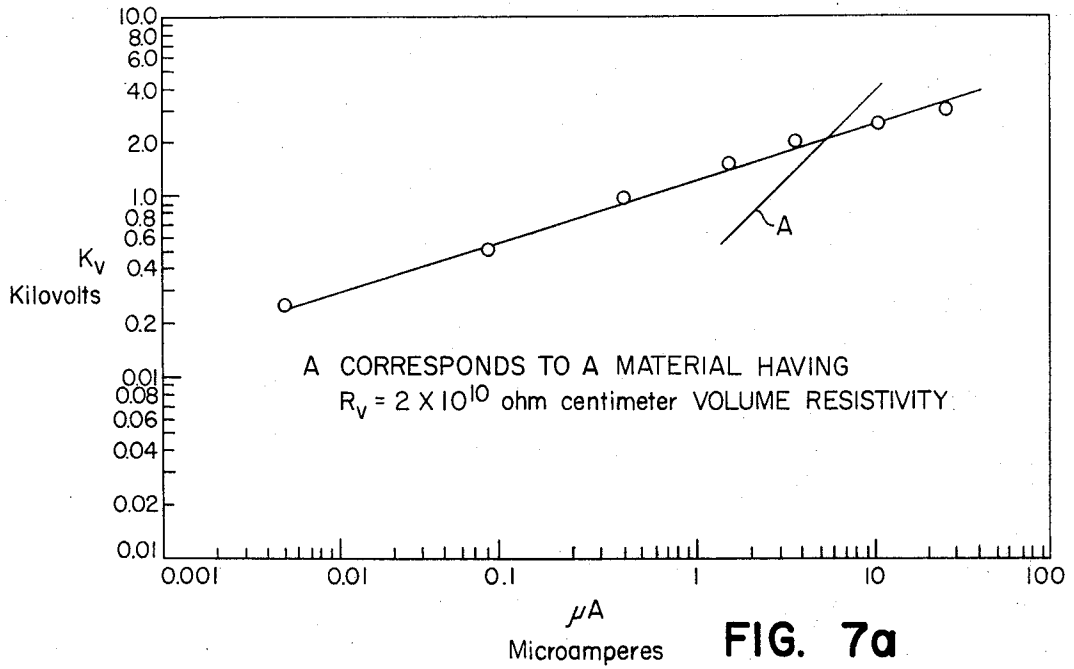

FIG. 7a

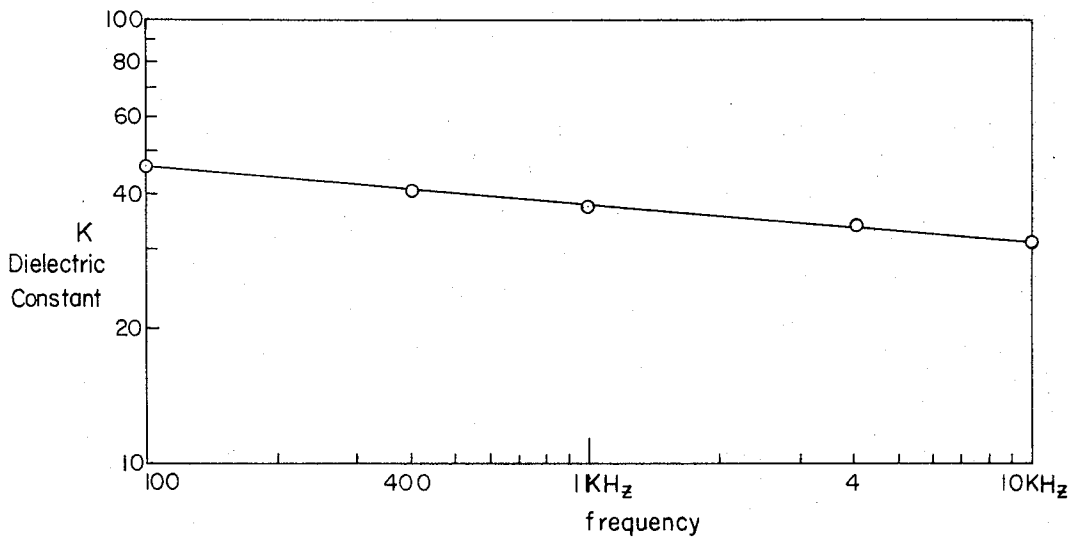

FIG. 7b

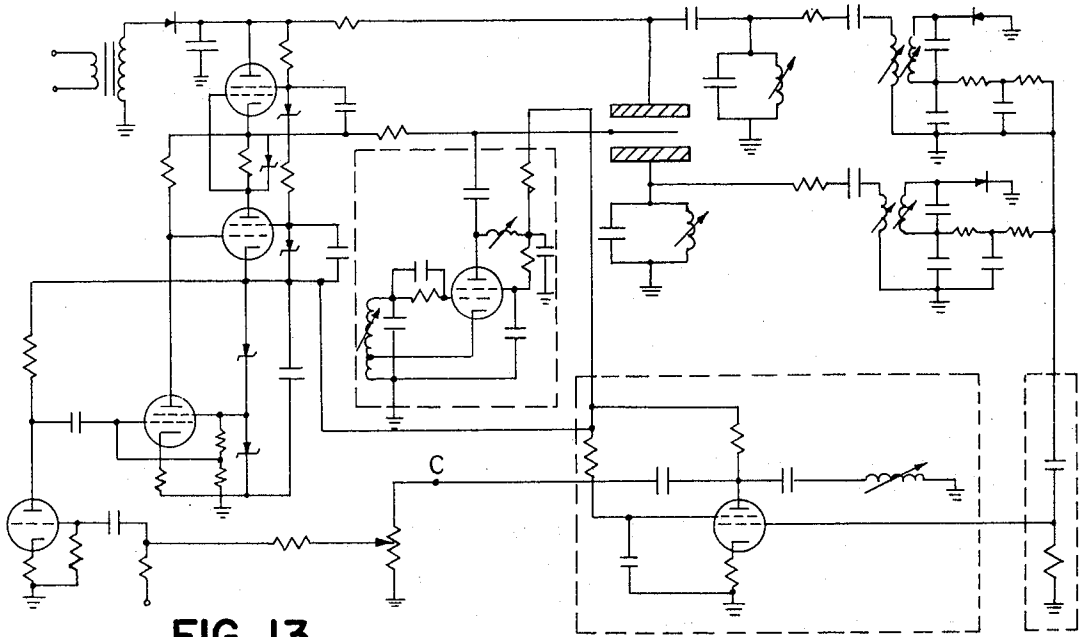

FIG. 13

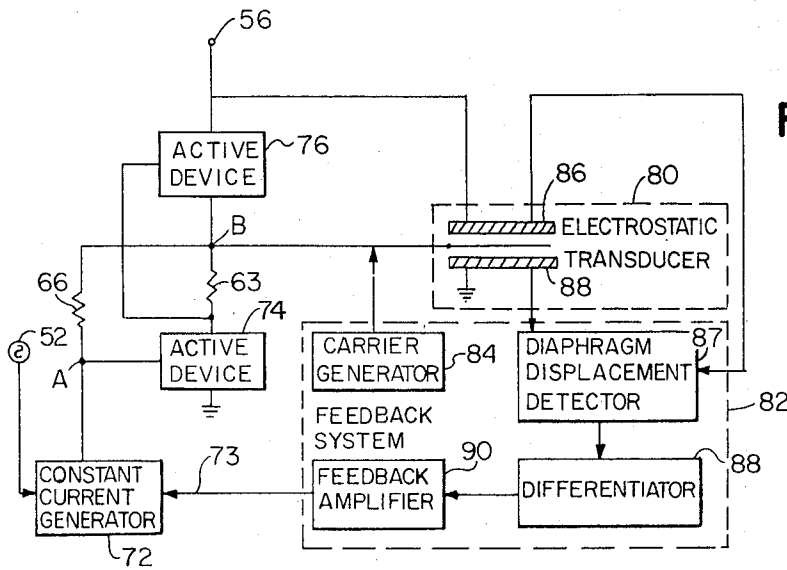

FIG. 12

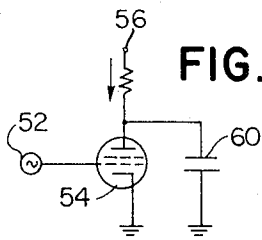

FIG. 10

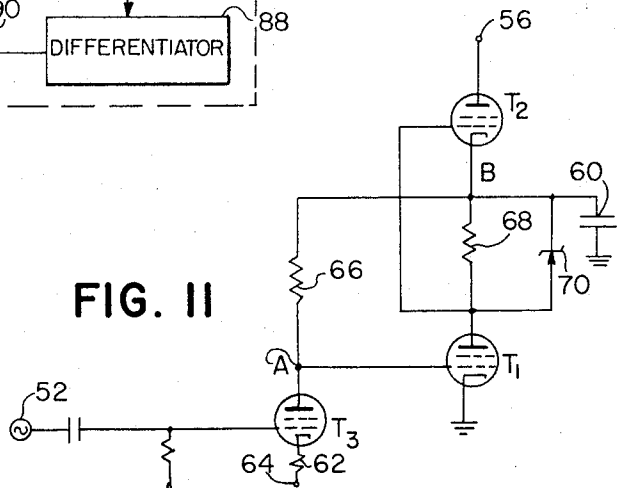

FIG. 11

FIG. 15

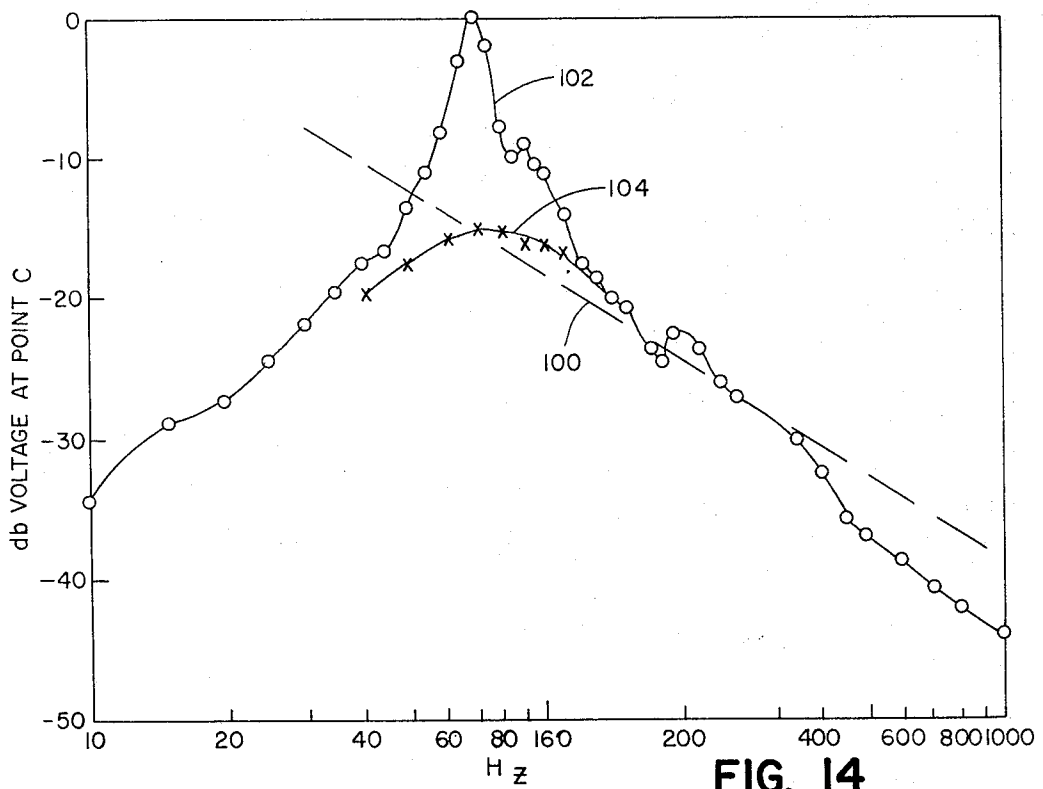
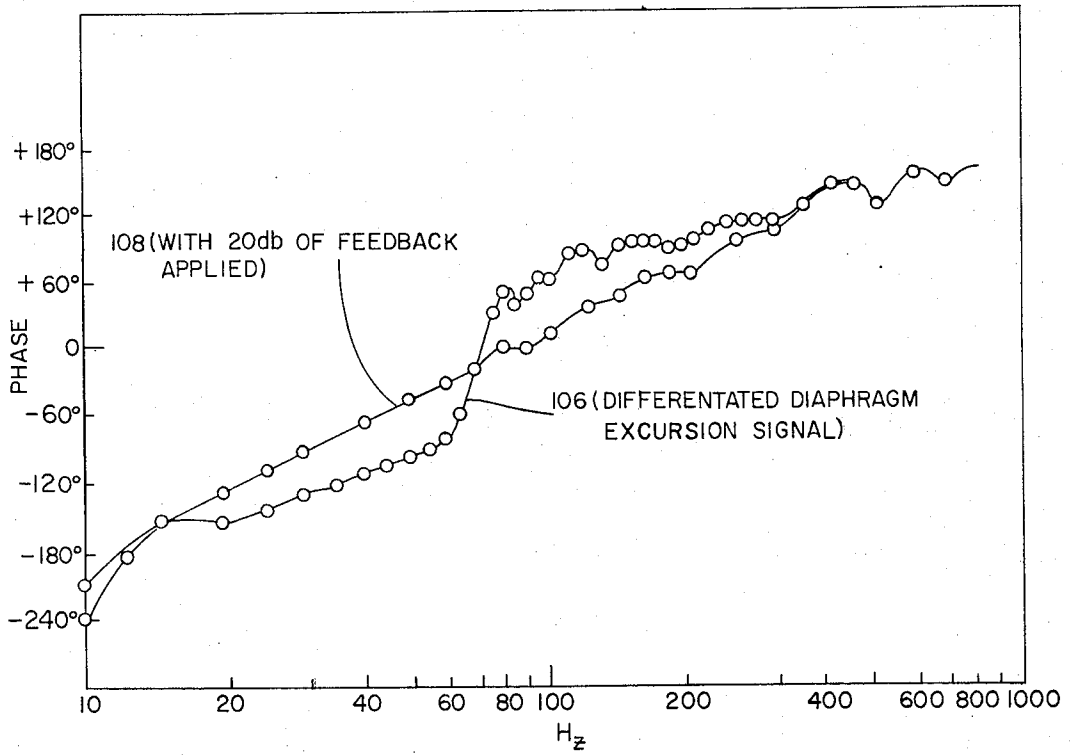

FIG. 14

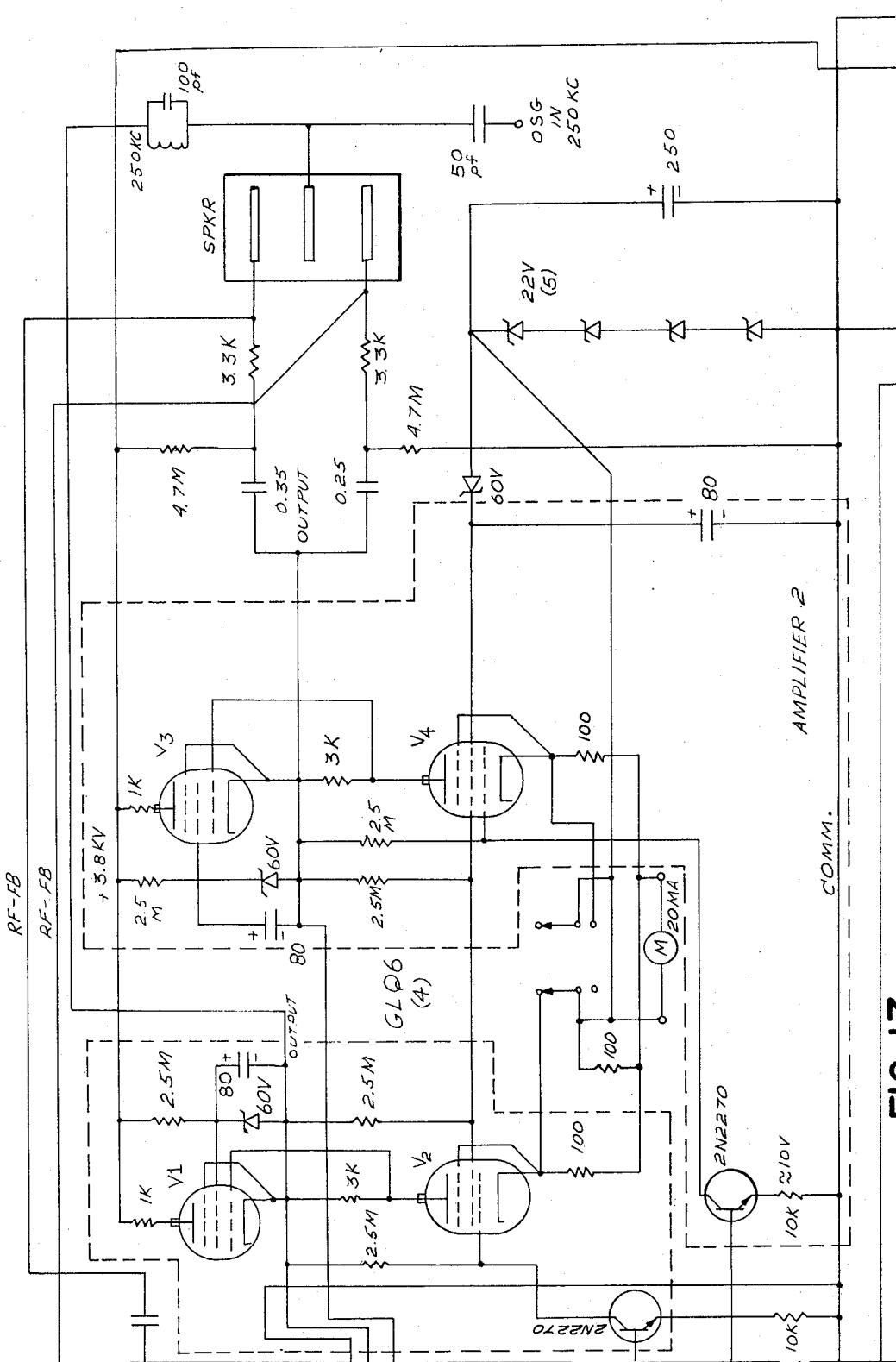

FIG. 17

ELECTROSTATIC LOUDSPEAKER AND AMPLIFIER

This is a division of application Ser. No. 833,952 filed June 17, 1969 now, U.S. Pat. No. 3,668,335.

This invention relates to electrostatic loudspeakers.

A principal object of the invention is to provide an electrostatic speaker system and components which solve or avoid in a practical way the various problems which exist for such speakers.

Another object is to provide an electrostatic loudspeaker capable of accurately reproducing sounds down to 40 to 50 Hz with ample volume and which is sufficiently compact as to be acceptable for use in homes.

Another object is to provide an electrostatic loudspeaker capable of accurately reproducing high frequency sound, frequencies from 1,000 to above 10,000 Hz and dispersing it over a wide solid angle (e.g., angles up to 180°).

Another object is to provide a full range electrostatic loudspeaker capable of accurate reproduction of both low and high frequencies.

Another object is to provide an electrostatic loudspeaker having an electrode construction and power source capable of achieving each and all of the foregoing objects as well as providing better performance generally for electrostatic speakers.

The invention features the combination of an electrostatic transducer with particular components to achieve the above objects. Featured is an electrostatic transducer surrounded by a rigid enclosure and having a constricted outlet throat smaller than the transducer, using the principle of the Helmholtz resonator, enabling the achievement of an acceptable low figure (e.g., below 50 Hz) for the natural frequency of resonance of the mechanical system in an enclosure which is sufficiently small to enable use in the home. Preferably, the volume of the enclosure exposed to the back side of the diaphragm is at least four times greater than the volume exposed to the front.

The invention further features an electrostatic transducer with means establishing equal length paths from various diaphragm portions terminating on the arc of a circle having a center on the sound path some distance from the diaphragm portions, the speaker thus being capable of dispersing high frequencies in a wide solid angle. A further feature of the invention is the combination in which the constricted throat of the enclosure outlet, which contributes to lowering the natural frequency of resonance of the system, also forms part of the geometry of the dispersing system. The invention also features a plurality of side-by-side narrow channels leading from corresponding portions of the transducer, and bending to disperse the entire range of audio frequencies. The inlet width of those channels which bend is generally less than the length of the shortest wave length sound to be dispersed, generally less than $1\frac{1}{2}$ and on the order of two-thirds inch for speakers having high frequency capability.

The invention further features a high voltage power system, with peak voltages exceeding 3,000 volts, employing thick electrodes of high dielectric constant (e.g., $30 < K < 60$) and a relatively low volume resistivity (e.g., R_v within therange of 10^8 and 10^{11} , preferably on the order of 10^{10} ohm centimeters).

Thick electrodes according to the invention may be considered to be those whose dielectric portions are

more than about three times that of the air gap involved. While large air gaps, electrode thicknesses on the order of one-fourth inch, and peak voltages in the range of 6,000 volts are employed for the preferred full range speaker, in its broader aspect this thick electrode feature of the invention applies to constructions in which both the air gap and the dielectric dimensions are scaled to smaller values. Such thick electrode systems avoid power arcs while achieving a relatively high energy output per unit diaphragm area, judged against other electrostatic speakers. The electrodes concentrate the electrostatic field in the air gap between the electrodes, protect the conductive diaphragm from arcing and enable voltage differences across the thickness of the electrodes to be rapidly eliminated, should such voltage differences occur. The transducer can present a capacitance on the order of 750 to 1,000 pf per square foot of diaphragm area and total capacitance ranging up to 2,000 pf and above, with virtually no resistive impedance in the operative frequency range, thus providing ample capability for the full range speaker of the invention.

To provide the high K electrodes the invention features an electrode molded of a dielectric matrix material in which is dispersed a substance of relatively much higher dielectric constant, e.g. $K < 500$, to achieve an electrode K advantageously greater than 30. A further additive is useful to lower the volume resistivity of the electrode to preferably on the order of 10^{10} ohm centimeters to achieve appropriate time constants.

Also featured is an amplifier capable of powering this system, the amplifier having active devices series-connected across a large DC voltage, with the output terminal for the electrostatic transducer located between the active devices. A third active device having high impedance (constant current generator) characteristics is controlled by the audio signal source and its output is connected to control one of the active devices, while it is also connected through a resistive feedback path to the output terminal. This achieves a high-voltage, low-impedance amplifier directly coupled to the electrostatic transducer.

Further featured is an electronic feedback loop which dampens the response of the speaker in the low frequency range. This feedback loop employs a carrier signal applied to the moving diaphragm, and detector circuits for both electrodes of a balanced speaker, the dielectric portion of the electrodes having a high K, e.g., $K < 15$, at the carrier frequency. Demodulation recovers a signal that varies with displacement of the diaphragm and differentiation of the signal provides an effective feedback signal proportional to diaphragm velocity and of proper phase.

These features, in combination, complement each other in a very interrelated way to achieve full audio range capability in a practical form. It is believed that certain versions of the system are capable of better sound reproduction in the home than any full range speaker system heretofore proposed; and that other versions permit a good level of quality to be achieved inexpensively.

While these features and others which will appear herein lead to a full frequency range electrostatic loudspeaker, they have use individually and in various sub-combinations, as will be apparent to those skilled in the art.

In the drawings:

FIG. 1 is a horizontal cross-sectional view of a full audio range electrostatic speaker according to the invention, including schematically an amplifier system;

FIG. 1a shows in greater detail the configuration of the lens walls for the loudspeaker of FIG. 1;

FIG. 2 is a perspective view of the loudspeaker of FIG. 1;

FIG. 3 is a partial vertical cross-sectional view of the speaker of FIGS. 1 and 2 taken on line 3—3 thereof;

FIG. 4 is a perspective view of the front portion of the lens system of FIGS. 1 and 1a, showing the outlet;

FIG. 5 is a perspective view similar to FIG. 4 viewed from the back to reveal the inlet of the lens system;

FIG. 6 is a cross-sectional view of an alternate form of lens construction;

FIG. 6a is a horizontal-sectional view of a transducer for use in the embodiment of FIG. 6;

FIG. 7 is a partially broken away perspective view of a preferred electrode plate;

FIGS. 7a and 7b are plots of electrical characteristics of electrode material according to the invention;

FIG. 8 is a cross-sectional view showing an edge member being formed on the electrode plate of FIG. 7;

FIG. 9 is a cross-sectional view of a balanced electrostatic transducer being formed from two electrodes in accordance with FIG. 8;

FIG. 10 is a schematic utilized to illustrate the difficulty of using conventional amplifier circuitry to drive a capacitive load;

FIG. 11 is a simplified schematic of an amplifier of the type provided by the present invention;

FIG. 12 is a block diagram of an entire loudspeaker system according to the invention; and

FIG. 13 is a detailed schematic of the electronic components of one practical embodiment of the invention;

FIGS. 14 and 15 are plots of characteristics of a preferred embodiment of the invention;

FIGS. 16, 17 and 18 together comprise a detailed schematic of another circuit according to the invention.

Referring to FIGS. 1-3 there is shown an embodiment of a full range electrostatic loudspeaker in accordance with the invention. The basic components comprise an electrostatic transducer 10 (including a large flexible diaphragm 12, e.g. of metal coated mylar, and a pair of rigid planar high K electrodes 14, 16), a rigid-walled enclosure 18 surrounding the transducer 10, an outlet passage, here in the form of a lens 20 and an amplifier 22 including a diaphragm-tracking feedback circuit 23.

The electrostatic transducer 10 extends across one third of the full width W of the enclosure 18, having a width W_d of 13 inches. The electrode assembly of the transducer has a height of 23 inches. A number of these can be mounted above each other if desired.

The electrostatic transducer of this embodiment is of the balanced type in which the flexible diaphragm 12 is held in taut condition between two apertured electrodes 14, 16. The sound absorbent material 19 (effective down to about 300 H_z) and the rigid walled enclosure 18 prevent backward moving radiation emitted by diaphragm 12 back through electrode 14 from escaping and causing cancellation of the forward radiation.

The forward electrode 16 is disposed immediately adjacent the inlet 20_i of the lens structure 20 (see FIG. 5). The lens is composed of a series of walls 20₁, 20₂, ... 20₁₉ (see FIG. 1a) which are straight in the vertical

direction (see FIGS. 4 and 5) but are spaced apart and curved in accordance with a special pattern in the horizontal direction to define a series of channels (see FIGS. 1 and 1a). Thus outer wall 20₁ and the next adjacent wall 20₂ define a channel (channel I) having an inlet of width W_1 exposed to a corresponding outer portion of diaphragm 12 (through the apertures 16a of the outer electrode 16). The walls 20₁ and 20₂ converge together in the direction outwardly and simultaneously curve toward the centerline of the lens, to the lens throat region 20_t.

Near this region the channels begin a re-entrant curve so that at the throat 20_t the channel is again substantially perpendicular to the diaphragm, although displaced significantly toward the centerline. Beyond this region the walls 20₁ and 20₂ curve outwardly from the centerline and diverge from each other, terminating in ends 20_e which, in this example, are disposed outside of the front wall 18a of enclosure 18. The axis A_1 of the outlet of channel I is thus directed outwardly at a substantial angle from its direction of the channel axis at the inlet. In like manner the other side of wall 20₂ and wall 20₃ define channel II. It is disposed to receive the sonic output of the next adjacent portion of the diaphragm. It curves and converges and diverges similarly to channel I while its output axis A_2 is disposed at a lesser angle to the normal to the diaphragm. Channel II provides the next adjacent segment of the solid angle α achieved by the lens. Channel III is likewise defined by the walls 20₃ and 20₄, and so on to channel IX, along which extends the centerline. The lens structure is symmetrical about the centerline, and thus the right hand outer channel XVIII curves in like manner, but in opposite direction, to channel I.

The outer portion of the walls 20₁ - 20₁₉ are shaped to establish the series of outlet axes $A_1 - A_{18}$, such that projections of these axes intersect at a common inward point C spaced substantially (e.g., 1 foot) from the diaphragm. Since a dispersed angle α of about one half a circle is desired for this embodiment center C lies on the plane projected through the front surface 18a of the enclosure. Preferably, as shown, the curvatures of the walls are arranged so that the sound path P along each of the channels and outwardly to a circle projected from the common center C of the outlets is the same length for all channels.

Thus

$$P_1 = P_2 = P_3 = \dots P_{17} = P_{18}.$$

The effect of these features is to emit a circular wave front even though the sound emitting diaphragm is both planar and extremely directional for the high frequencies. With a suitable shaping of the walls, the wave form can be spherical, however in the preferred embodiment shown, the speaker retains the same circular horizontal cross-section throughout its height, hence the output sound wave is of cylindrical form, which can spread to fill a room with high frequency sound. The walls may be made of various conventional speaker materials, e.g., paper stock of appropriate grade. The outer channels may be of lesser width than the inner channels (e.g., $W_1 < W_9$) taking advantage of the fact that the smaller the filament of sound, the more it can be bent without distortion. For outer channels especially, the channel width should be based upon the shortest audio wave length of interest and in general should be less than 1 1/2 inches. Practical limits exist however because to narrow a channel introduces too much resistance to

the travel of the sound. Thus it is found that channel width on the order of two-thirds of an inch for the channels is suitable. A practical rule. For channels which turn significantly, is that the inlet width of the channel should approximate the wave length of the highest frequency of interest.

The potential mid frequency mismatch resulting from reflected waves of the channels is believed to be overcome by varying from channel to channel the distance from the diaphragm to the point (20_i) at which the constricted throat occurs. Referring still to FIGS. 1 and 1a it will be observed that although the throat 20_i for the various channels occurs at the same plane parallel to the diaphragm, this represents different path lengths to the diaphragm. Thus the path length of channel I from its portion of the diaphragm to the throat 20_i is longer than the corresponding path of the next adjacent channel II.

The throat 20_i is sized, in relation to the given enclosure, to provide a sufficiently low natural frequency of resonance (e.g., below the frequencies of bass organ and bass drum) in accordance with the laws relating to Helmholtz resonators, and in general will be less than half as wide as the transducer for enclosures of suitably limited size.

Also the volume of the enclosure exposed to the back side of the transducer (Volume I, FIG. 1) should be a plurality of times greater than the volume of the enclosure exposed to the front side of the transducer, as measured from the diaphragm 12 to the outlet (Volume II, FIG. 1). Advantageously the ratio of Volume I to Volume II should be greater than 4.

In this embodiment the restricted throat is three inches wide contrasted to the one foot width of the sound-emitting diaphragm which is surrounded by this enclosure, and the lens outlet has a width of about 7 inches. The enclosure width W is 36 inches, depth d is 18 inches and height h is 72 inches, the front edges of the enclosure being chamfered as shown. Volume I bears the ratio to Volume II of about 10 to 1.

In this embodiment the ends 20_e of the walls defining the channels protrude beyond front wall 18_a and the axes A_1 and A_{18} of the outlets of channels I and XVIII on the extremities are substantially parallel to front wall 18_a, see FIG. 1a, in order to achieve a solid angle of dispersion α approximately 180°. The ends 20_e are hidden from view in a simple manner by grill cloth 17. In this case the cloth is anchored at points 21 and 22 at the beginning of the chamfer of the front edges of the enclosure (the chamfers decrease the bulky appearance of the enclosure). The grill cloth extends at a substantially similar angle to the chamfers to stand-off projections 23 located at the intersection of the chamfers and the front panel 18_a, these projections being acoustically transparent. The projections 23 extend as far from the front panel 18_a as do the ends 20_e of the channel-forming walls, and the grill cloth stretched between these projections covers these ends and gives the speaker a finished appearance.

It may be noted that in the instance of using such a speaker as this merely as a woofer, only the outside walls 20_i and 20₁₉ of the lens, FIG. 1a, would be required, still keeping the constricted throat. However, high and low frequency component mismatch, cross-over network difficulties and other significant problems are avoided and economies achieved by the full range speaker of the present embodiment.

To illustrate that the concept for reducing the frequency of low frequency resonance and dispersal of high frequencies by a restricted aperture lens system may not be limited to the preferred channeled lens construction, reference is made to FIGS. 6 and 6a. There is shown an enclosure 30 surrounding an electrostatic driver 32. The principle of this speaker would be the same as that of the preceding figures in this respect: a restricted aperture 31, or throat which is substantially narrower than the surrounded driver 32 provides (by the principle of the Helmholtz resonator) a natural frequency of resonance of the mechanical system below the lowest frequencies (e.g., bass organ and bass drum) that are to be reproduced, and the backward radiation of the transducer is contained by the enclosure. At the same time the transducer is arranged so that its sounds seem to emanate from a center C spaced from the diaphragm and near the front wall 30_a of the enclosure. The paths P from adjacent portions of the diaphragm (32₁, 32₂...32₅) radiate from this center so as to disperse the high frequency sounds through a wide solid angle. The lengths of the paths (e.g., p_1 , p_2 ... p_5) from the respective portions of the diaphragm to a circle centered on C are substantially of the same length.

Referring to the specific structure of FIGS. 6 and 6a, the form of the transducer 32 approximates the arc of a circle and the concave portion of the transducer is directed toward the aperture 31. (Although a single circular line is shown in FIG. 6, it will be understood that the transducer preferably comprises opposed apertured electrodes with a flexible diaphragm disposed therebetween in a balanced construction). The transducer is arranged with the focal point (the point of intersection of the normals to the diaphragm surface) at the position of the desired center for radiation C , e.g., near the plane 30_a of the front of the enclosure. Thus the high frequency radiations, in following paths normal to the diaphragm portions, pass through the center, adjacent paths crossing each other. Since the normals of adjacent surface portions lie at angles to each other, the net effect is a circular wave form emanating from the aperture. FIG. 6 is a horizontal cross-section of the speaker. The speaker can have uniform cross-section throughout a substantial height, so it generates a cylindrical wave form, to disperse high frequency radiation in a wide solid angle α .

As illustrated in FIG. 6a, it may be possible to approximate a circular cross-section transducer by a number of planar units 32₁, 32₂...32₅, disposed as chords of a circle, thus to take advantage of the simplifications attendant with the use of planar members. It also may be advantageous to employ rounded transition surfaces 35 between the front wall 30_a of the enclosure and the guide walls 36 which extend from each outer diaphragm portion to the aperture 31. This lens construction could be used in tweeter and mid-range speakers as can the lens system of FIG. 1-3, but one of its virtues, like that of the system of FIG. 1-3, would be the possibility of use in lower range and full frequency range speakers in which a lowered resonant frequency and avoidance of cancellation and reinforcement due to the back wave would be achieved.

Referring to FIG. 9, in the preferred embodiment of the invention a conductive diaphragm 12 is employed. With such diaphragms the use of a bare conductive fixed electrode would lead to power arcs that can destroy the diaphragm. It is realized that coating of the

electrodes with high dielectric strength coatings would still leave the problem of imperfection and pinholes permitting destructive power arcs. This whole class of problem is avoided according to the invention by using thick high dielectric constant electrodes, i.e., dielectric portions about three or more times greater in thickness than the air gap on the respective side of the diaphragm, assuming the diaphragm to be in mid-position.

The electrode featured by the invention for meeting these unusual dielectric requirements is a molded member comprised of a dielectric matrix in which a substance of relatively higher dielectric constant (preferably $K > 500$) has been dispersed. The result is an electrode whose construction permits tailor-made electrical properties with high K values. Such electrodes permit sufficient force per unit of diaphragm area to be applied to power the loudspeaker being described.

The matrix material may be selected from the various moldable dielectric substances that are available, but particularly good results are achieved using epoxy, which has dielectric constants below 10, e.g., $K = 4$ to 6. To this material is added, previous to molding, a dispersion of a substance selected for having a much higher dielectric constant (such as barium titanate, $K = 1,000$ to 1,500). Advantageously, also a dispersion of semi-conductive substance (such as carbon) is added, having a lower volume resistivity than the matrix material to achieve a volume resistivity in the range of 10^8 to 10^{11} ohm centimeters, the preferred value being about 10^{10} ohm centimeters.

The properties of the resulting electrode are not linear. That is, whereas a linear resistor has a slope of one in the IE plot, for the actual material the slope is on the order of one-third. Also the dielectric constant at high frequency drops to approximately two-thirds of its low frequency value. Some idea of the operational properties of the material may be seen by computing pseudo time constant for mid-range values, with the assumption of linearity of these properties. Referring to FIGS. 7a and 7b, curves of a typical embodiment, the material is seen at mid-frequency range to have a dielectric constant of about 40 and a volume resistivity of 2×10^{10} ohm centimeters. This corresponds to a pseudo time constant of 0.2 seconds. In actuality the time constant at this particular frequency will be somewhat longer due to the lesser slope of the volume resistivity curve of the actual material.

It is found that time constants considerably greater than one second make recovery of operation of the speaker in the event of overload unduly long. On the other hand, if volume resistivity is too low, in the case of the diaphragm touching the electrode, too large a current flows which can impair the tension of the mylar diaphragm.

With the dielectric constant K in the preferred range of 30 to 60 and with the volume resistivity lying within the range of about 10^8 and 10^{11} ohm centimeters, satisfactory performance is obtained.

The dielectric constant of the material according to this invention remains substantially high into the range of several hundred kilocycles permitting the use of a carrier frequency for measuring diaphragm movement and velocity for negative feedback purposes, discussed further below.

According to a suitable procedure for preparing the electrode barium titanate and carbon powders are mixed together with a suitably-proportioned mass of

epoxy in the liquid state, prior to reaction. The mixture is then cast into a mold in the desired form and cured.

Referring to FIG. 7 a broken away portion of the preferred electrode plate is shown, formed by the casting procedure. The matrix material illustrated by the dashed cross-hatching is No. 2038 epoxy; and No. 3416 hardener, manufactured by Houghton Laboratories of Olean, New York, in the ratio of one part by weight hardener to ten parts 2038.

The triangles shown in the cross-section of FIG. 7 diagrammatically suggest the uniform dispersion of fine barium titanate particles and the circles shown in the cross-section similarly suggest the uniform dispersion of carbon particles. Employing substantially equal amounts of barium titanate and 2038, with carbon approximately 5 percent of the weight of the epoxy produces a suitable electrode construction with dielectric constant in the range of $K = 30$ to 40 and volume resistivity in the region of $R_v = 10^{10}$ ohm centimeters.

In one preferred embodiment the electrode plate consists of the following percentages, of the various ingredients:

	parts by weight
epoxy 2038	100
barium titanate	100
epoxy hardener 3416	10
carbon	5.3
	(being 4.8 per cent of the total epoxy)

Referring again to FIG. 7, the slots molded integrally into the electrode plate 14 have length L on the order of 2 inches, inlet width S_1 of $1 \frac{1}{16}$ inch, and the slot walls diverge to an outlet width S_2 of one-eighth inch. Each land between the slots has a width on the inlet side of three-sixteenths inch and converges to a width of one-eighth inch on the outlet side. The electrode thickness t is on the order of one-quarter inch.

The inlet surface of the electrode is cast precisely planar and smooth. The outlet surface is smooth and after formation is coated with a conductive layer 14c, FIG. 9, e.g., an epoxy containing a dispersion of fine silver-coated particles. Thereafter, the electrode plate may be baked for curing, e.g., 140° F. for a few hours.

After formation the electrode plate 14a is appropriately jigged, see Fig. 8, and an edge member 14b is molded integrally therewith. A planar casting plate 38, e.g., of plate glass forms the inside edge surface 14c of the edge member 14b. A removable spacer 40 of uniform thickness approximating one-half the thickness of the desired air gap rests upon the casting plate 38 and directly supports the inlet surface of the electrode during this operation. Jig members 42 and 44 form the outline of the edge member 14b. The edge member may be formed of the same material as the matrix of the electrode plate, however omitting the additives.

Referring to FIG. 9, two such electrode members 14 and 16 are brought together, inner surfaces directed toward each other and frame surfaces 14c aligned. A thin flexible conductive diaphragm 12 (e.g., a polyester film such as Dupont's Mylar, of between one-quarter to one-half mil thickness, carrying on each side a vacuum-deposited aluminum coating) is disposed between the electrodes. Tension T (of several thousand p.s.i.) is applied to the diaphragm between the electrode whereupon the electrodes are permanently clamped to the diaphragms, e.g., by means of adhesive applied to mating surfaces 14c or by bolting the two electrodes to-

gether. The thus formed electrostatic driver is then ready for mounting within the speaker enclosure, see FIGS. 1-3.

For full range electrostatic speakers the polarizing voltage across the fixed electrodes may range between about 2 to 8 kilovolts. The air gap between the diaphragm (in mid-position) and either fixed electrode ranges between one-twentieth to one-tenth inch and it is found that the thickness of the electrode preferably should be of the order of one-quarter inch.

The signal voltage is divided across the electrode thickness and the air gap. To lose as little signal voltage across the electrode and to concentrate the signal voltage to the air gap the electrode of high dielectric constant (e.g., greater than 30) is employed. A maximum limit on electrode thickness is found to exist because of lowering of the slot resonant frequency with increasing thickness. A minimum thickness limit is found to exist because of the need to avoid power arcs. For higher K , lower conductance is needed, but R_p too low is found to give problems, for example greater tendency for the diaphragm to stick to the electrode should contact be made, and localized heating and resultant damage to the diaphragm.

The desired level of leakiness (i.e., the volume resistivity) is advantageously achieved by the addition of a dispersion of carbon, as noted above.

In the example of the preferred embodiment, see FIG. 9, the polarizing voltage together with the audio peak is established at 6,000 volts between diaphragm and electrode, the air gap A_0 is 0.070 inch, the effective dielectric constant of the electrode material averages $K = 40$ (varying little with frequency), the thickness t of the electrode is about one-quarter inch. The volume resistivity of the electrode is adjusted by the amount of carbon present in the electrode matrix, (between 10^8 and 10^9 ohm centimeters) to establish a time constant of less than one second, preferably less than 0.1 second. By this is meant that less than one or 0.1 second is required for a voltage between the inner and outer faces of the electrode to drop to one-third of its value.

The electrostatic speaker of the invention imposes severe operating requirements upon the associated amplifier system. To obtain the requisite levels of audio output without requiring an unduly large diaphragm, the audio drive voltage must be quite high, a peak drive potential of 4,000 volts being employed. The speaker impedance is almost entirely capacitive (3,000 to 6,000 pf.) and peak currents in excess of 300 ma. are sometimes required, implying a peak output requirement of many hundreds of bolt amperes. The output transformers generally used to drive conventional moving-coil speakers (which have a relatively low and essentially resistive impedance, e.g., 8 ohms) are peculiarly ill suited to the demands of the electrostatic speaker. Transformers having the requisite output are cumbersome, expensive, and present resonance problems when used to drive a capacitive load.

A simple schematic is presented in FIG. 10 to illustrate the difficulties of driving an electrostatic speaker directly from the output of a conventional resistance-coupled amplifier. An audio input signal 52 is applied to amplifying tube 54 and a plate supply voltage of +4,000 volts is applied to terminal 56. If capacitive load 60 is 3,000 pf. its impedance at 10 KHz is about 5,500 ohms. For the loss in response at that frequency to be limited to 3 db. plate resistor 58 can be no larger than

5,500 ohms. The plate supply would then have to furnish about 375 ma. or 1,500 watts to terminal 56. This "brute force" method of driving a speaker is, of course, highly inefficient and impractical.

The inventor has devised a low-impedance amplifier circuit that produces the required output with efficiency, stability, linearity, and a relatively low-level input. A simplified schematic of this circuit is shown in FIG. 11. An audio input signal 52 of about 10-volt amplitude is applied to the grid of pentode T3. (Like elements are designated with identical reference numerals throughout all the figures). The terminal 56 plate supply of pentode T2 is +4,000 volts. Capacitor 60, representing the load presented by the electrostatic speaker, has a value of 3,000 pf. A -100 volt potential is applied to 10 K cathode resistor 62 at terminal 64. The output signal at point B ranges from a value close to ground to almost +4,000 volts, and may furnish a peak current of over 300 mg. in either direction to load 60.

In the quiescent no-input state, pentode T3 develops a well-defined plate current of slightly over 1 ma. through the 2M feedback resistor 66. About 2,040 volts is developed over resistor 66 so that point B settles at a quiescent voltage of about +2,000 volts, while point A settles at about -40 volts. About 6 ma. flows from terminal 56 through pentode T2, 7 K resistor 68 and pentode T1.

Point B is held stable at +2,000 volts by feedback resistor 66. Should it tend to rise to a higher voltage, the voltage increase would be applied through resistor 66 to the grid of pentode T1, causing T1 to conduct more heavily and thus lowering the output voltage at point B. Conversely, were the voltage at point B to tend to fall to a lower value, the drop would also be fed back through resistor 66, reducing the conduction through pentode T1 and increasing the plate voltage of T1 and decreasing the voltage between grid and cathode of pentode T2 (the grid of T2 is directly coupled to the plate of T1). The resulting increase in conduction through T2 causes the voltage at point B to rise restoring the equilibrium output value of +2,000 volts.

The small-signal output impedance of the circuit is extremely low. Assume, for example, that pentodes T1 and T2 each have a transconductance of 1,000 microhms and that a 1 volt incremental voltage is applied to point B. This incremental voltage is fed back through resistor 66 to the grid of T1, resulting in a 1 ma. increase in the plate current of T1 and a 7 volt increase in the drop across resistor 68. The resulting 7 volt increase in the grid bias of T2 reduces the cathode current of T2 by 7 ma. The total change in current at point B (as seen by the load) is thus the increase in the plate current of T1 plus the decrease in the cathode current of T2 (1 ma. + 7 ma. = 8 ma.). The small-signal output impedance of the amplifier is therefore only 1 volt/8 ma. = 125 ohms.

Only a few tens of volts of drive are required from the plate of pentode T3 which, in driving point A, closely approximates a very linear constant current generator. The large unbypassed cathode resistor 62 increases the effective output impedance of the T3 stage. (The effective resistance looking into the plate of T3 can be as high as 1 M). Series-connected pentodes T1 and T2 function essentially as class B amplifiers, but the linearity of their operation is greatly increased by the 40 to 50 db. of negative feedback provided by resistor 66.

Further linearity improvement can be achieved by customary feedback from point B to 52.

For large signal inputs, the amplifier can furnish very high peak currents, both positive and negative, to load 60. When pentode T2 conducts, the output current is limited only by the current capacity of T2 at low or zero bias, and peak currents of many hundreds of ma. can be furnished to the load.

When pentode T1 conducts, the output current is, in first instance, limited by the 7 K resistor 68. However, by shunting a 100 volt Zener diode 70 across resistor 68, the voltage drop can be limited to 100 volts and the current which T1 can supply to the load can then, for all practical purposes, be limited only by the current capacity of pentode T1 rather than by resistor 68.

A block diagram showing the entire electronic section of the system is presented in FIG. 12. This block diagram incorporates amplifier elements similar to those shown in FIG. 11 and in addition shows the audio feedback system used to damp the low frequency resonance of the system.

An audio input signal 52 is applied to input amplifier 72, a high-impedance, constant current stage or set of stages (which may even be solid state) serving the function of pentode T3 in FIG. 11, and also serving to combine the audio input 52 with a feedback signal on line 73. Active devices 74 and 76, which occupy roles similar to those of pentodes T1 and T2 respectively, (but of course need not necessarily be pentodes) are connected in series between a high voltage source at terminal 56 and ground. Diaphragm 78 of electrostatic transducer 80 is electrically connected to Point B, the junction of active devices 74 and 76, as is feedback resistor 66.

It is realized that damping of the low frequency resonance peak is desired. To a certain degree this is possible by viscous damping, e.g., using glass wool designed immediately adjacent to the back of the transducer as suggested in dotted lines at 19a in FIG. 1. Electronically this same damping is well achieved by feedback system 82. Carrier generator 84 applies at a 260 KC signal to diaphragm 78. This signal induces corresponding signals at electrodes 86 and 88 of electrostatic transducer 80. The amplitude of each of these signals varies with the distance of the diaphragm from the electrode; the closer the diaphragm, the stronger the signal. The induced carrier signals on the two electrodes are detected and summed at diaphragm displacement detector 87. Successful operation is made possible by the fact that with the dielectric electrode made as described above, a substantial K (believed to be greater than about 15) exists at the frequency of the carrier wave.

The resulting signal, centered around a zero voltage and ranging positive or negative depending upon the direction of diaphragm displacement from the center position, is proportional to diaphragm displacement and is in quadrature with the transducer drive voltage at the resonant frequency. Diaphragm excursion should be inversely proportional to the frequency squared (i.e., displacement decreases 12 db. for each octave of frequency increase). The output of diaphragm displacement detector 86 is applied to differentiator 88, which generates a signal advanced in phase by 90° (and thus approximately in phase with the drive voltage). The amplitude of this differentiated signal is inversely

proportional to frequency and so decreases 6 db. for each octave of frequency increase.

The differentiator output signal is applied to feedback amplifier 90 which introduces a further 180° phase shift in the signal. The output from the feedback amplifier is returned through line 74 to constant current generator 72 and there summed with audio input signal 52. (The feedback system 82 is designed so that the line 74 feedback signal is significant only from about 20 Hz to about 200 Hz; its phase at those frequencies is such as to oppose the drive voltage.) To produce constant sound energy throughout the frequency range of the system (with constant drive amplitude) the system response curve should drop about 6 db per octave, ideally approaching line 100 in FIG. 14. The characteristics of the electrostatic speaker are such that there would, without feedback, be about a 15 db resonant peak 102 in the response corresponding to the acoustic resonance of the speaker. The use of the feedback system 82 not only flattens out this peak as shown at 104, but also renders the phase response of the system far more linear. The phase response without feedback is shown in FIG. 15 at 106; phase response with feedback is shown at 108.

A detailed schematic drawing is shown in FIG. 13 of those system components represented in block form in FIG. 12. This practical circuit illustrates one presently preferred implementation of the electronic portions of the electrostatic speaker system.

A further schematic drawing is shown in FIG. 16 of a system employing certain of the elements in solid state, and thus constituting a reduction to practice using components that are practical for production. In this embodiment two amplifiers of identical construction are employed, one connected to the diaphragm and the other to the fixed electrodes as shown, with a 180° phase shift between the two. This arrangement is generally suggested in FIG. 1 as well. For a given amount of audio signal a considerably more powerful output is obtained, relative to a one-amplifier embodiment.

Numerous variations in the specific details are possible within the spirit and scope of the invention.

What is claimed is:

1. An electrostatic loudspeaker comprising the combination of a balanced transducer, an amplifier and an enclosure, said transducer comprising a pair of electrodes between which is mounted a diaphragm, said electrodes being apertured members having a thickness greater than about three times the air gap between the electrode and the diaphragm in mid-position and a dielectric constant greater than about thirty said amplifier connected to drive said transducer and comprising a pair of active devices connected in series, the first controlling the second, an output terminal connected between said active and a third active device comprising a constant current source connected to receive and amplify the audio signal, the output of said third active device connected to control the first said series-connected active devices, and the output terminal of said amplifier connected through a resistive feedback path to the output of said third active device, and said enclosure surrounding said transducer and adapted to contain the backward-moving sound emitted from one side of said transducer and an air-column-defining outlet passage for forward-moving sound emitted from the other side of said transducer, said outlet passage com-

prising a series of side by side channels curving together from said transducer to a throat region and then curving apart to disperse the sound.

2. The electrostatic transducer of claim 1 wherein said electrode comprising an apertured plate cast of a matrix material and a dispersion of an additive having a dielectric constant substantially greater than that of said matrix material.

3. The electrostatic transducer of claim 1 including means producing a feedback signal to said amplifier for combating a low frequency response peak comprising a single carrier wave generator connected to said diaphragm, a pair of pick-up circuits connected respectively to said electrodes, a displacement detector circuit responsive to said pick-up circuits and means to produce the differential of the displacement signal and apply it to the input of said amplifier.

4. The electrostatic transducer of claim 1 wherein said output channels have inlets disposed immediately adjacent said electrode and said channels collectively define a throat having an effective cross-section area less than one half the sound emitting area of said electrode.

5. The transducer of claim 4 where said channels are defined by a set of walls which converge toward each other to said throat and then diverge from each other to outlets which collectively distribute the sound over a semicircular arc.

6. In an electrostatic loudspeaker system comprising an electrostatic transducer, a power source for applying to said transducer a polarizing voltage, and an audio amplifier for applying to said transducer an audio signal, the improvement wherein said audio amplifier comprises the combination of a pair of active devices connected in series, the first controlling the second, an output terminal of said amplifier connected between said active devices, and a third active device comprising substantially a constant current generator connected to receive and amplify the audio signal, the output of said third active device connected to control the first of said series connected active devices, and the output terminal of said amplifier connected through a resistive feedback path to the output of said third active device.

7. The loudspeaker system of claim 6 wherein the input of said second of said series connected active devices is directly connected across the resistive load of the first active device.

8. The electrostatic loudspeaker of claim 6 having two electrodes, one on each side of the diaphragm, including a second amplifier constructed according to the aforementioned amplifier, wherein the output terminal of one of said amplifiers is connected to said diaphragm, the output terminal of the second of said amplifiers is connected to both electrodes, and phase inverter means is provided to invert the audio input of one of said amplifiers with respect to the other.

9. The electrostatic loudspeaker system of claim 6 wherein each of said active devices comprises elements performing the functions respectively of cathode, grid and plate, the plate element of the first active device connected through a resistor to the amplifier output terminal and the cathode element of the second active device, the cathode element of the first active device and the plate element of the second active device connected across a DC potential in excess of one thousand volts, the plate element of the second device being positive, the plate element of the first active device being connected to the grid element of the second active device, and the grid element of the first active device connected to the plate of said third active device and to feedback from said output terminal.

10. The electrostatic loudspeaker system of claim 9 wherein an element performing the function of a zener diode is also connected between the output terminal and the plate element of said first active device, across said resistor, thereby preventing said resistor from limiting the amount of current which said first active device can supply to said output terminal.

11. The electrostatic loudspeaker system of claim 9 wherein said first and second active devices comprise pentodes.

12. The electrostatic loudspeaker system of claim 11 wherein said transducer has a capacitance on the order of 3,000 pf requiring peak current in excess of 100 ma. with a polarizing voltage on the order of 4,000 volts, said pentodes having a transconductance (Gm) on the order of 1,000 ohms and the resistance of said feedback path is on the order of 2 megohms.

13. The electrostatic loudspeaker system of claim 6 having two electrodes, one on each side of the diaphragm, wherein said power source is connected to apply said polarizing voltage across said electrodes and said output terminal is connected to said diaphragm.

* * * * *

50

55

60

65

UNITED STATES PATENT OFFICE
CERTIFICATE OF CORRECTION

Patent No. 3,773,976 Dated November 20, 1973

Inventor(s) HAROLD N. BEVERIDGE

It is certified that error appears in the above-identified patent and that said Letters Patent are hereby corrected as shown below:

- Column 1, line 57, "1 1/2" should be --1 1/2"--;
- Column 3, line 16, after "horizontal", insert --cross- --;
- Column 4, line 30, "and rules for" should read -- 20₄ --.
- Column 4, line 37, "intersect" is misspelled;
- Column 10, line 19, "mg." should be --ma.--;
- Column 10, line 47, "through" is misspelled;
- Column 11, line 38, "designed" should be --disposed--;
- Column 11, line 42, delete the word "at";
- Column 12, line 56, after the word "active", insert --devices--;
- Column 13, line 5, "comprising" should be --comprises--;
- Column 14, line 16, "cathode" is misspelled.

Signed and sealed this 4th day of June 1974.

(SEAL)
Attest:

EDWARD M. FLETCHER, JR.
Attesting Officer

C. MARSHALL DANN
Commissioner of Patents