



INTERNATIONAL APPLICATION PUBLISHED UNDER THE PATENT COOPERATION TREATY (PCT)

(51) International Patent Classification ⁶ : G01R 19/02, H02M 3/335	A3	(11) International Publication Number: WO 98/43100 (43) International Publication Date: 1 October 1998 (01.10.98)
(21) International Application Number: PCT/IB98/00249 (22) International Filing Date: 27 February 1998 (27.02.98) (30) Priority Data: 97200856.9 21 March 1997 (21.03.97) EP (34) Countries for which the regional or international application was filed: NL et al. (71) Applicant: KONINKLIJKE PHILIPS ELECTRONICS N.V. [NL/NL]; Groenewoudseweg 1, NL-5621 BA Eindhoven (NL). (71) Applicant (for SE only): PHILIPS NORDEN AB [SE/SE]; Kottbygatan 7, Kista, S-164 85 Stockholm (SE). (72) Inventors: PANSIER, Frans; Prof. Holstlaan 6, NL-5656 AA Eindhoven (NL). MARINUS, Antonius, Adrianus, Maria; Prof. Holstlaan 6, NL-5656 AA Eindhoven (NL). BUTHKER, Henricus, Cornelis, Johannes; Prof. Holstlaan 6, NL-5656 AA Eindhoven (NL). (74) Agent: GROENENDAAL, Antonius, W., M.; Internationaal Octrooibureau B.V., P.O. Box 220, NL-5600 AE Eindhoven (NL).	(81) Designated States: JP, European patent (AT, BE, CH, DE, DK, ES, FI, FR, GB, GR, IE, IT, LU, MC, NL, PT, SE). Published <i>With international search report.</i> <i>Before the expiration of the time limit for amending the claims and to be republished in the event of the receipt of amendments.</i> (88) Date of publication of the international search report: 28 January 1999 (28.01.99)	

(54) Title: CURRENT AND VOLTAGE SENSING**(57) Abstract**

An integrated circuit (1) comprises a voltage sensing circuit (2) and a current mirror (3) for sensing both a voltage (V_i) and a current (I_i) at one input terminal (T) of the integrated circuit. The voltage sensing circuit (2) comprises an input connected to the input terminal (T) and an output supplying a voltage level indication (V_u). The current mirror (3) has an input also connected to the input terminal (T), a reference terminal connected to a reference potential, and an output supplying an output current (I_u). The input of the current mirror has a high impedance as long as the voltage level (V_i) is below a threshold voltage (V_{th}) of the current mirror (3). Within a voltage range determined by this threshold voltage (V_{th}), the voltage level indication (v_u) is a measure of the voltage level (V_i). The current mirror (3) becomes active and the output current (I_u) is a mirrored input current (I_i) if the voltage level (V_i) exceeds the threshold voltage (V_{th}). The threshold voltage may be determined by an input transistor (T1) of the current mirror (3). This input transistor (T1), which is arranged as a diode, starts conducting if the voltage level (V_i) reaches the threshold voltage (V_{th}) of this diode.

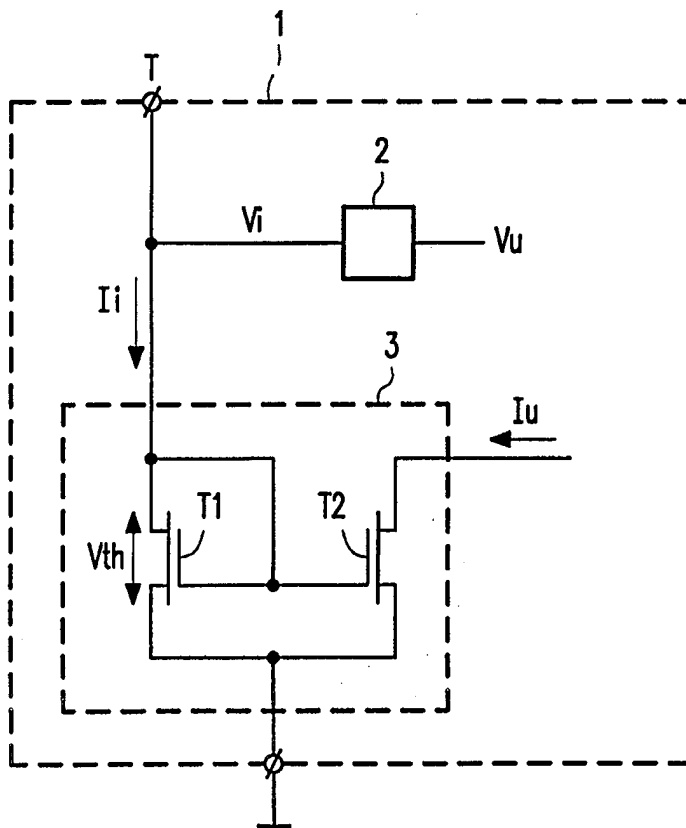

FOR THE PURPOSES OF INFORMATION ONLY

Codes used to identify States party to the PCT on the front pages of pamphlets publishing international applications under the PCT.

AL	Albania	ES	Spain	LS	Lesotho	SI	Slovenia
AM	Armenia	FI	Finland	LT	Lithuania	SK	Slovakia
AT	Austria	FR	France	LU	Luxembourg	SN	Senegal
AU	Australia	GA	Gabon	LV	Latvia	SZ	Swaziland
AZ	Azerbaijan	GB	United Kingdom	MC	Monaco	TD	Chad
BA	Bosnia and Herzegovina	GE	Georgia	MD	Republic of Moldova	TG	Togo
BB	Barbados	GH	Ghana	MG	Madagascar	TJ	Tajikistan
BE	Belgium	GN	Guinea	MK	The former Yugoslav Republic of Macedonia	TM	Turkmenistan
BF	Burkina Faso	GR	Greece	ML	Mali	TR	Turkey
BG	Bulgaria	HU	Hungary	MN	Mongolia	TT	Trinidad and Tobago
BJ	Benin	IE	Ireland	MR	Mauritania	UA	Ukraine
BR	Brazil	IL	Israel	MW	Malawi	UG	Uganda
BY	Belarus	IS	Iceland	MX	Mexico	US	United States of America
CA	Canada	IT	Italy	NE	Niger	UZ	Uzbekistan
CF	Central African Republic	JP	Japan	NL	Netherlands	VN	Viet Nam
CG	Congo	KE	Kenya	NO	Norway	YU	Yugoslavia
CH	Switzerland	KG	Kyrgyzstan	NZ	New Zealand	ZW	Zimbabwe
CI	Côte d'Ivoire	KP	Democratic People's Republic of Korea	PL	Poland		
CM	Cameroon	KR	Republic of Korea	PT	Portugal		
CN	China	KZ	Kazakstan	RO	Romania		
CU	Cuba	LC	Saint Lucia	RU	Russian Federation		
CZ	Czech Republic	LI	Liechtenstein	SD	Sudan		
DE	Germany	LK	Sri Lanka	SE	Sweden		
DK	Denmark	LR	Liberia	SG	Singapore		
EE	Estonia						

INTERNATIONAL SEARCH REPORT

International application No.

PCT/IB 98/00249

A. CLASSIFICATION OF SUBJECT MATTER		
IPC6: G01R 19/02, H02M 3/335 According to International Patent Classification (IPC) or to both national classification and IPC		
B. FIELDS SEARCHED		
Minimum documentation searched (classification system followed by classification symbols)		
IPC6: G01R, H02M		
Documentation searched other than minimum documentation to the extent that such documents are included in the fields searched		
SE,DK,FI,NO classes as above		
Electronic data base consulted during the international search (name of data base and, where practicable, search terms used)		
WPI		
C. DOCUMENTS CONSIDERED TO BE RELEVANT		
Category*	Citation of document, with indication, where appropriate, of the relevant passages	Relevant to claim No.
A	US 5369308 A (F.A.C.M. SCHOOF ET AL.), 29 November 1994 (29.11.94), figure 1, abstract --	1-6
A	US 5378936 A (N. KOKUBO ET AL.), 3 January 1995 (03.01.95), figure 1, abstract --	1-6
A	US 4648016 A (G. PERUTH ET AL.), 3 March 1987 (03.03.87), figures 1,3, abstract --	1-6
A	US 5138201 A (S. OHBAYASHI ET AL.), 11 August 1992 (11.08.92), figure 1, abstract -- -----	1-6
<input type="checkbox"/> Further documents are listed in the continuation of Box C. <input checked="" type="checkbox"/> See patent family annex.		
* Special categories of cited documents: "A" document defining the general state of the art which is not considered to be of particular relevance "E" earlier document but published on or after the international filing date "L" document which may throw doubts on priority claim(s) or which is cited to establish the publication date of another citation or other special reason (as specified) "O" document referring to an oral disclosure, use, exhibition or other means "P" document published prior to the international filing date but later than the priority date claimed "T" later document published after the international filing date or priority date and not in conflict with the application but cited to understand the principle or theory underlying the invention "X" document of particular relevance: the claimed invention cannot be considered novel or cannot be considered to involve an inventive step when the document is taken alone "Y" document of particular relevance: the claimed invention cannot be considered to involve an inventive step when the document is combined with one or more other such documents, such combination being obvious to a person skilled in the art "&" document member of the same patent family		
Date of the actual completion of the international search		Date of mailing of the international search report
7 December 1998		08 -12- 1998
Name and mailing address of the ISA/ Swedish Patent Office Box 5055, S-102 42 STOCKHOLM Facsimile No. +46 8 666 02 86		Authorized officer Lars Jakobsson Telephone No. +46 8 782 25 00

INTERNATIONAL SEARCH REPORT

Information on patent family members

03/11/98

International application No.

PCT/IB 98/00249

Patent document cited in search report	Publication date	Patent family member(s)	Publication date
US 5369308 A	29/11/94	DE 69311921 D,T	29/01/98
		EP 0554936 A,B	11/08/93
		JP 5300726 A	12/11/93
US 5378936 A	03/01/95	JP 2761687 B	04/06/98
		JP 5175801 A	13/07/93
US 4648016 A	03/03/87	DE 3330039 A	28/02/85
		DK 60584 A	20/02/85
		EP 0135119 A,B	27/03/85
		FI 87410 B	15/09/92
		FI 843271 A	20/02/85
		JP 2044148 C	09/04/96
		JP 7059150 B	21/06/95
		JP 60062869 A	11/04/85
US 5138201 A	11/08/92	JP 2533399 B	11/09/96
		JP 4030393 A	03/02/92
		US 5222045 A	22/06/93