

(19) World Intellectual Property Organization  
International Bureau



(43) International Publication Date  
3 April 2003 (03.04.2003)

PCT

(10) International Publication Number  
**WO 03/026943 A2**

(51) International Patent Classification<sup>7</sup>: **B61B**

(21) International Application Number: PCT/US02/29335

(22) International Filing Date:  
17 September 2002 (17.09.2002)

(25) Filing Language: English

(26) Publication Language: English

(30) Priority Data:  
09/960,820 21 September 2001 (21.09.2001) US

(71) Applicant: **TIME DOMAIN CORPORATION**  
[US/US]; 7057 Old Madison Pike, Huntsville, AL 35806 (US).

(81) Designated States (*national*): AE, AG, AL, AM, AT, AU, AZ, BA, BB, BG, BR, BY, BZ, CA, CH, CN, CO, CR, CU, CZ, DE, DK, DM, DZ, EC, EE, ES, FI, GB, GD, GE, GH, GM, HR, HU, ID, IL, IN, IS, JP, KE, KG, KP, KR, KZ, LC, LK, LR, LS, LT, LU, LV, MA, MD, MG, MK, MN, MW, MX, MZ, NO, NZ, OM, PH, PL, PT, RO, RU, SD, SE, SG, SI, SK, SL, TJ, TM, TN, TR, TT, TZ, UA, UG, UZ, VN, YU, ZA, ZM, ZW.

(84) Designated States (*regional*): ARIPO patent (GH, GM, KE, LS, MW, MZ, SD, SL, SZ, TZ, UG, ZM, ZW), Eurasian patent (AM, AZ, BY, KG, KZ, MD, RU, TJ, TM), European patent (AT, BE, BG, CH, CY, CZ, DE, DK, EE, ES, FI, FR, GB, GR, IE, IT, LU, MC, NL, PT, SE, SK, TR), OAPI patent (BF, BJ, CF, CG, CI, CM, GA, GN, GQ, GW, ML, MR, NE, SN, TD, TG).

**Published:**  
— *without international search report and to be republished upon receipt of that report*

*For two-letter codes and other abbreviations, refer to the "Guidance Notes on Codes and Abbreviations" appearing at the beginning of each regular issue of the PCT Gazette.*

(72) Inventors: **GRISHAM, William, T.**; 313 Westburg Avenue, Huntsville, AL 35801 (US). **ROBERTS, Mark, D.**; 416 Zandale Drive, Huntsville, AL 35801 (US).

(74) Agent: **TUCKER, William, J.**; 8650 Southwestern Blvd. #2825, Dallas, TX 75206-2688 (US).

(54) Title: RAILROAD COLLISION AVOIDANCE SYSTEM AND METHOD FOR PREVENTING TRAIN ACCIDENTS

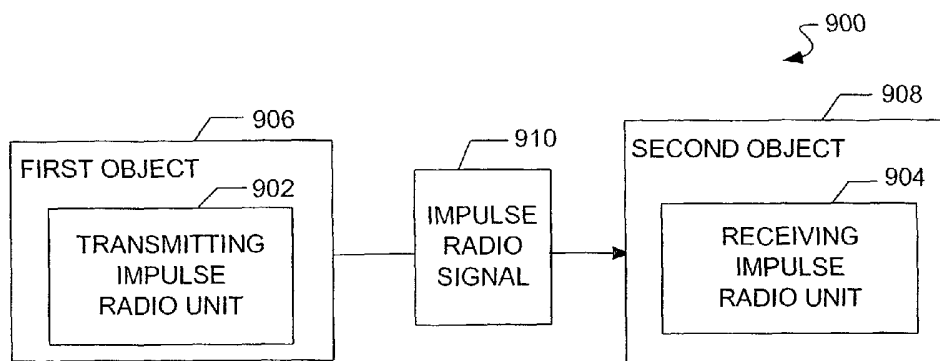

(57) **Abstract:** A railroad collision avoidance system (900) and method (1000) are disclosed that utilize impulse radio technology to effectively warn a person when there is a locomotive in their vicinity. In one embodiment, the railroad collision avoidance system (900) includes a transmitting impulse radio unit (902) coupled to a locomotive (906) and a receiving impulse radio unit (904) coupled to a vehicle (908). The transmitting impulse radio unit (902) operates to transmit an impulse radio signal (910) towards the vehicle (908) when the locomotive (906) is a predetermined distance from a railroad crossing. Upon receiving the impulse radio signal (910), the receiving impulse radio unit (904) makes sure the person operating the vehicle (908) is informed about the potentially dangerous situation. Several embodiments of the railroad collision avoidance system (900) and method (1000) are disclosed all of which operate to warn a person when there is a locomotive in their vicinity.

WO 03/026943 A2

**RAILROAD COLLISION AVOIDANCE SYSTEM AND METHOD FOR  
PREVENTING TRAIN ACCIDENTS**

**BACKGROUND OF THE INVENTION**

Field of the Invention

The present invention generally relates to the railroad field and, in particular, to a railroad collision avoidance system and method for preventing train accidents.

Description of Related Art

When it comes to public safety and personal safety, it is always desirable to improve upon the way people are warned about potentially dangerous situations involving a locomotive. To date there does not appear to be any railroad collision avoidance system that can effectively warn a person when there is a locomotive in their vicinity. Presently, there are approximately 259,000 railroad crossings in the United States of which approximately 22% are active railroad crossings which means that they are protected by some sort of railroad collision avoidance system. The conventional railroad collision avoidance system uses warning lights and retractable gates to alert a motorist that there is an oncoming locomotive. This means that over 200,000 railroad crossings are passive railroad crossings which are particularly dangerous since they have no warning lights or retractable gates to warn a motorist that a locomotive is approaching the railroad crossing. Even with the use of

conventional railroad collision avoidance systems at the active railroad crossings and the lack of collision avoidance systems at passive railroad crossings there is still an unacceptable number of  
5 train-vehicle accidents. For instance, in 1999, there were 399 deaths and 1360 people seriously injured in train-vehicle accidents in the United States.

In past years, several railroad collision avoidance systems have been patented in an attempt to  
10 reduce the number of train-vehicle accidents. One such system was described in U.S. Patent No. 4,942,395 which appears to disclose a wireless railroad grade crossing motorist warning system that warns motorists traveling within a given proximity of a railroad  
15 crossing that there is an oncoming train. The wireless railroad grade crossing motorist warning system uses a three-transceiver system, wherein the oncoming train has a mounted transceiver that communicates a warning radio signal to a transceiver  
20 located at a railroad grade crossing which, in turn, emits a coded radio signal to a transceiver unit located within a motor vehicle. Unfortunately, the wireless railroad grade crossing motorist warning system uses conventional radio communication  
25 technology and as such suffers from the traditional problems associated with that technology including, for example, interference from other radios, high power consumption and multipath interference.

Another system was described in U.S. Patent No.  
30 5,864,304 which appears to disclose a railroad-crossing warning system for protecting pedestrians and

motorists from an oncoming train. In one embodiment, the railroad-crossing warning system has six magnetic probes that cover a 40x40 foot area in the railroad crossing that detects the presence of a stalled  
5 vehicle. If there is a stalled vehicle, the railroad-crossing warning system communicates information about the stalled vehicle to the oncoming train. In addition, the railroad-crossing warning has a series of wireless trackside devices that are equally spaced  
10 along the length of the railroad track for detecting the presence of the oncoming train at a specified location and time and for determining vital warning information about the oncoming train. The train warning information is transmitted to a two-sided  
15 light emitting (LED) display located at the railroad crossing. While this system is an improvement over many others it is still subject to interference from other transmitters and must operate within an assigned frequency that can be adversely affected by different  
20 types of interference commonly associated with traditional communication technology. Accordingly, there has been a need for a railroad collision avoidance system and method that can effectively warn a person when there is a locomotive in their vicinity.  
25 This need and other needs are satisfied by the railroad collision avoidance system and method of the present invention.

#### **BRIEF DESCRIPTION OF THE INVENTION**

30 The present invention includes a railroad collision avoidance system and method that utilize

impulse radio technology to effectively warn a person when there is a locomotive in their vicinity. In one embodiment, the railroad collision avoidance system includes a transmitting impulse radio unit coupled to a locomotive and a receiving impulse radio unit coupled to a vehicle. The transmitting impulse radio unit operates to transmit an impulse radio signal towards the vehicle when the locomotive is a predetermined distance from a railroad crossing. Upon receiving the impulse radio signal, the receiving impulse radio unit makes sure the person operating the vehicle is informed about the potentially dangerous situation. Several different embodiments of the railroad collision avoidance system and method all of which operate to warn a person when there is a locomotive in their vicinity are described below.

#### **BRIEF DESCRIPTION OF THE DRAWINGS**

A more complete understanding of the present invention may be had by reference to the following detailed description when taken in conjunction with the accompanying drawings wherein:

FIG. 1A illustrates a representative Gaussian Monocycle waveform in the time domain;

FIG. 1B illustrates the frequency domain amplitude of the Gaussian Monocycle of FIG. 1A;

FIG. 1C represents the second derivative of the Gaussian Monocycle of FIG. 1A;

FIG. 1D represents the third derivative of the Gaussian Monocycle of FIG. 1A;

FIG. 1E represents the Correlator Output vs. the Relative Delay in a real data pulse;

5        FIG. 1F graphically depicts the frequency plot of the Gaussian family of the Gaussian Pulse and the first, second, and third derivative.

FIG. 2A illustrates a pulse train comprising pulses as in Fig. 1A;

10        FIG. 2B illustrates the frequency domain amplitude of the waveform of Fig. 2A;

FIG. 2C illustrates the pulse train spectrum;

FIG. 2D is a plot of the Frequency vs. Energy Plot and points out the coded signal energy spikes;

15        FIG. 3 illustrates the cross-correlation of two codes graphically as Coincidences vs. Time Offset;

FIG. 4A-4E graphically illustrate five modulation techniques to include: Early-Late Modulation; One of Many Modulation; Flip Modulation; Quad Flip  
20 Modulation; and Vector Modulation;

FIG. 5A illustrates representative signals of an interfering signal, a coded received pulse train and a coded reference pulse train;

FIG. 5B depicts a typical geometrical configuration giving rise to multipath received signals;

FIG. 5C illustrates exemplary multipath signals  
5 in the time domain;

FIGS 5D - 5F illustrate a signal plot of various multipath environments.

FIGS. 5G illustrates the Rayleigh fading curve associated with non-impulse radio transmissions in a  
10 multipath environment.

FIG. 5H illustrates a plurality of multipaths with a plurality of reflectors from a transmitter to a receiver.

FIG. 5I graphically represents signal strength as  
15 volts vs. time in a direct path and multipath environment.

FIG. 6 illustrates a representative impulse radio transmitter functional diagram;

FIG. 7 illustrates a representative impulse radio  
20 receiver functional diagram;

FIG. 8A illustrates a representative received pulse signal at the input to the correlator;

FIG. 8B illustrates a sequence of representative impulse signals in the correlation process;

FIG. 8C illustrates the output of the correlator for each of the time offsets of Fig. 8B.

FIG. 9 is a block diagram illustrating the basic components of a railroad collision avoidance system of  
5 the present invention.

FIG. 10 is a flowchart illustrating the basic steps of a preferred method of the present invention that helps to prevent train accidents.

FIG. 11 is a diagram illustrating in greater  
10 detail the components of a first embodiment of the railroad collision avoidance system shown in FIG. 9.

FIG. 12 is a flowchart illustrating in greater detail the steps of a first embodiment of the  
15 preferred method shown in FIG. 10.

FIG. 13 is a diagram illustrating in greater detail the components of a second embodiment of the  
20 railroad collision avoidance system shown in FIG. 9.

FIG. 14 is a flowchart illustrating in greater detail the steps of a second embodiment of the preferred method shown in FIG. 10.

FIG. 15 is a diagram illustrating in greater  
25 detail the components of a third embodiment of the railroad collision avoidance system shown in FIG. 9.



FIG. 16 is a flowchart illustrating in greater detail the steps of a third embodiment of the preferred method shown in FIG. 10.

5 FIG. 17 is a diagram illustrating in greater detail the components of a fourth embodiment of the railroad collision avoidance system shown in FIG. 9.

FIG. 18 is a flowchart illustrating in greater  
10 detail the steps of a fourth embodiment of the preferred method shown in FIG. 10.

FIG. 19 is a diagram illustrating in greater  
15 detail the components of a fifth embodiment of the railroad collision avoidance system shown in FIG. 9.

FIG. 20 is a flowchart illustrating in greater  
20 detail the steps of a fifth embodiment of the preferred method shown in FIG. 10.

FIG. 21 is a diagram illustrating in greater  
25 detail the components of a sixth embodiment of the railroad collision avoidance system shown in FIG. 9.

FIG. 22 is a flowchart illustrating in greater  
30 detail the steps of a sixth embodiment of the preferred method shown in FIG. 10.

#### **DETAILED DESCRIPTION OF THE INVENTION**

30 The present invention includes a railroad collision avoidance system and method that utilize

impulse radio technology to effectively warn a person when there is a locomotive in their vicinity. In one embodiment, the railroad collision avoidance system includes a transmitting impulse radio unit coupled to  
5 a locomotive and a receiving impulse radio unit coupled to a vehicle. The transmitting impulse radio unit operates to transmit an impulse radio signal towards the vehicle when the locomotive is a predetermined distance from a railroad crossing. Upon  
10 receiving the impulse radio signal, the receiving impulse radio unit makes sure the person operating the vehicle is informed about the potentially dangerous situation. Several different embodiments of the railroad collision avoidance system and method all of  
15 which operate to warn a person when there is a locomotive in their vicinity are described below.

Although the present invention is described as using impulse radio technology, it should be understood that the present invention can be used with  
20 any type of ultra wideband technology, but is especially suited for use with time-modulated ultra wideband technology. Accordingly, the railroad collision avoidance system and method should not be construed in a limited manner.

25 Impulse radio has been described in a series of patents, including U.S. Patent Nos. 4,641,317 (issued February 3, 1987), 4,813,057 (issued March 14, 1989), 4,979,186 (issued December 18, 1990) and 5,363,108 (issued November 8, 1994) to Larry W. Fullerton. A  
30 second generation of impulse radio patents includes U.S. Patent Nos. 5,677,927 (issued October 14, 1997),

5,687,169 (issued November 11, 1997), 5,764,696 (issued June 9, 1998), and 5,832,035 (issued November 3, 1998) to Fullerton et al.

Uses of impulse radio systems are described in U.S. Patent Application No. 09/332,502, titled, "System and Method for Intrusion Detection using a Time Domain Radar Array" and U.S. Patent Application No. 09/332,503, titled, "Wide Area Time Domain Radar Array" both filed on June 14, 1999 both of which are assigned to the assignee of the present invention. The above patent documents are incorporated herein by reference.

This section provides an overview of impulse radio technology and relevant aspects of communications theory. It is provided to assist the reader with understanding the present invention and should not be used to limit the scope of the present invention. It should be understood that the terminology 'impulse radio' is used primarily for historical convenience and that the terminology can be generally interchanged with the terminology 'impulse communications system, ultra-wideband system, or ultra-wideband communication systems'. Furthermore, it should be understood that the described impulse radio technology is generally applicable to various other impulse system applications including but not limited to impulse radar systems and impulse positioning systems. Accordingly, the terminology 'impulse radio' can be generally interchanged with the terminology 'impulse transmission system and impulse reception system.'

Impulse radio refers to a radio system based on short, low duty-cycle pulses. An ideal impulse radio waveform is a short Gaussian monocycle. As the name suggests, this waveform attempts to approach one cycle  
5 of radio frequency (RF) energy at a desired center frequency. Due to implementation and other spectral limitations, this waveform may be altered significantly in practice for a given application. Many waveforms having very broad, or wide, spectral  
10 bandwidth approximate a Gaussian shape to a useful degree.

Impulse radio can use many types of modulation, including amplitude modulation, phase modulation, frequency modulation, time-shift modulation (also  
15 referred to as pulse-position modulation or pulse-interval modulation) and M-ary versions of these. In this document, the time-shift modulation method is often used as an illustrative example. However, someone skilled in the art will recognize that  
20 alternative modulation approaches may, in some instances, be used instead of or in combination with the time-shift modulation approach.

In impulse radio communications, inter-pulse spacing may be held constant or may be varied on a  
25 pulse-by-pulse basis by information, a code, or both. Generally, conventional spread spectrum systems employ codes to spread the normally narrow band information signal over a relatively wide band of frequencies. A conventional spread spectrum receiver correlates these  
30 signals to retrieve the original information signal. In impulse radio communications, codes are not

typically used for energy spreading because the monocycle pulses themselves have an inherently wide bandwidth. Codes are more commonly used for channelization, energy smoothing in the frequency domain, resistance to interference, and reducing the interference potential to nearby receivers. Such codes are commonly referred to as time-hopping codes or pseudo-noise (PN) codes since their use typically causes inter-pulse spacing to have a seemingly random nature. PN codes may be generated by techniques other than pseudorandom code generation. Additionally, pulse trains having constant, or uniform, pulse spacing are commonly referred to as uncoded pulse trains. A pulse train with uniform pulse spacing, however, may be described by a code that specifies non-temporal, i.e., non-time related, pulse characteristics.

In impulse radio communications utilizing time-shift modulation, information comprising one or more bits of data typically time-position modulates a sequence of pulses. This yields a modulated, coded timing signal that comprises a train of pulses from which a typical impulse radio receiver employing the same code may demodulate and, if necessary, coherently integrate pulses to recover the transmitted information.

The impulse radio receiver is typically a direct conversion receiver with a cross correlator front-end that coherently converts an electromagnetic pulse train of monocycle pulses to a baseband signal in a single stage. The baseband signal is the basic

information signal for the impulse radio communications system. A subcarrier may also be included with the baseband signal to reduce the effects of amplifier drift and low frequency noise. Typically, the subcarrier alternately reverses modulation according to a known pattern at a rate faster than the data rate. This same pattern is used to reverse the process and restore the original data pattern just before detection. This method permits alternating current (AC) coupling of stages, or equivalent signal processing, to eliminate direct current (DC) drift and errors from the detection process. This method is described in more detail in U.S. Patent No. 5,677,927 to Fullerton et al.

15

#### **Waveforms**

Impulse transmission systems are based on short, low duty-cycle pulses. Different pulse waveforms, or pulse types, may be employed to accommodate requirements of various applications. Typical pulse types include a Gaussian pulse, pulse doublet (also referred to as a Gaussian monocycle), pulse triplet, and pulse quadlet as depicted in Figs. 1A through 1D, respectively. An actual received waveform that closely resembles the theoretical pulse quadlet is shown in Fig. 1E. A pulse type may also be a wavelet set produced by combining two or more pulse waveforms (e.g., a doublet/triplet wavelet set). These different pulse types may be produced by methods described in the patent documents referenced above or

30

by other methods, as persons skilled in the art would understand.

For analysis purposes, it is convenient to model pulse waveforms in an ideal manner. For example, the transmitted waveform produced by supplying a step function into an ultra-wideband antenna may be modeled as a Gaussian monocycle. A Gaussian monocycle (normalized to a peak value of 1) may be described by:

$$f_{mono}(t) = \sqrt{e} \left( \frac{t}{\sigma} \right) e^{\frac{-t^2}{2\sigma^2}}$$

where  $\sigma$  is a time scaling parameter,  $t$  is time, and  $e$  is the natural logarithm base.

The power spectral density of the Gaussian monocycle is shown in Fig. 1F, along with spectrums for the Gaussian pulse, triplet, and quadlet. The corresponding equation for the Gaussian monocycle is:

$$F_{mono}(f) = (2\pi)^{\frac{3}{2}} \sigma f e^{-2(\pi\sigma f)^2}$$

The center frequency ( $f_c$ ), or frequency of peak spectral density, of the Gaussian monocycle is:

$$f_c = \frac{1}{2\pi\sigma}$$

It should be noted that the output of an ultra-wideband antenna is essentially equal to the derivative of its input. Accordingly, since the pulse doublet, pulse triplet, and pulse quadlet are the first, second, and third derivatives of the Gaussian pulse, in an ideal model, an antenna receiving a

Gaussian pulse will transmit a Gaussian monocycle and an antenna receiving a Gaussian monocycle will provide a pulse triplet.

5           **Pulse Trains**

Impulse transmission systems may communicate one or more data bits with a single pulse; however, typically each data bit is communicated using a sequence of pulses, known as a pulse train. As  
10 described in detail in the following example system, the impulse radio transmitter produces and outputs a train of pulses for each bit of information. Figs. 2A and 2B are illustrations of the output of a typical 10 megapulses per second (Mpps) system with uncoded,  
15 unmodulated pulses, each having a width of 0.5 nanoseconds (ns). Fig. 2A shows a time domain representation of the pulse train output. Fig 2B illustrates that the result of the pulse train in the frequency domain is to produce a spectrum comprising a  
20 set of comb lines spaced at the frequency of the 10 Mpps pulse repetition rate. When the full spectrum is shown, as in Fig. 2C, the envelope of the comb line spectrum corresponds to the curve of the single Gaussian monocycle spectrum in Fig. 1F. For this  
25 simple uncoded case, the power of the pulse train is spread among roughly two hundred comb lines. Each comb line thus has a small fraction of the total power and presents much less of an interference problem to a receiver sharing the band. It can also be observed  
30 from Fig. 2A that impulse transmission systems typically have very low average duty cycles, resulting



in average power lower than peak power. The duty cycle of the signal in Fig. 2A is 0.5%, based on a 0.5 ns pulse duration in a 100 ns interval.

The signal of an uncoded, unmodulated pulse train  
5 may be expressed:

$$s(t) = (-1)^f a \sum_j \omega(ct - jT_f, b)$$

where  $j$  is the index of a pulse within a pulse train,  $(-1)^f$  is polarity (+/-),  $a$  is pulse amplitude,  $b$  is pulse type,  $c$  is pulse width,  $\omega(t, b)$  is the normalized  
10 pulse waveform, and  $T_f$  is pulse repetition time.

The energy spectrum of a pulse train signal over a frequency bandwidth of interest may be determined by summing the phasors of the pulses at each frequency, using the following equation:

$$A(\omega) = \left| \sum_{i=1}^n \frac{e^{j\Delta t}}{n} \right|$$

where  $A(\omega)$  is the amplitude of the spectral response at a given frequency.  $\omega$  is the frequency being analyzed ( $2\pi f$ ),  $\Delta t$  is the relative time delay of each pulse from the start of time period, and  $n$  is the  
20 total number of pulses in the pulse train.

A pulse train can also be characterized by its autocorrelation and cross-correlation properties. Autocorrelation properties pertain to the number of pulse coincidences (i.e., simultaneous arrival of  
25 pulses) that occur when a pulse train is correlated against an instance of itself that is offset in time.

Of primary importance is the ratio of the number of pulses in the pulse train to the maximum number of coincidences that occur for any time offset across the period of the pulse train. This ratio is commonly  
5 referred to as the main-lobe-to-side-lobe ratio, where the greater the ratio, the easier it is to acquire and track a signal.

Cross-correlation properties involve the potential for pulses from two different signals  
10 simultaneously arriving, or coinciding, at a receiver. Of primary importance are the maximum and average numbers of pulse coincidences that may occur between two pulse trains. As the number of coincidences increases, the propensity for data errors increases.  
15 Accordingly, pulse train cross-correlation properties are used in determining channelization capabilities of impulse transmission systems (i.e., the ability to simultaneously operate within close proximity).

## 20           **Coding**

Specialized coding techniques can be employed to specify temporal and/or non-temporal pulse characteristics to produce a pulse train having certain spectral and/or correlation properties. For  
25 example, by employing a PN code to vary inter-pulse spacing, the energy in the comb lines presented in Figure 2B can be distributed to other frequencies as depicted in Figure 2D, thereby decreasing the peak spectral density within a bandwidth of interest. Note  
30 that the spectrum retains certain properties that depend on the specific (temporal) PN code used.

Spectral properties can be similarly affected by using non-temporal coding (e.g., inverting certain pulses).

Coding provides a method of establishing independent communication channels. Specifically, families of codes can be designed such that the number of pulse coincidences between pulse trains produced by any two codes will be minimal. For example, Fig. 3 depicts cross-correlation properties of two codes that have no more than four coincidences for any time offset. Generally, keeping the number of pulse collisions minimal represents a substantial attenuation of the unwanted signal.

Coding can also be used to facilitate signal acquisition. For example, coding techniques can be used to produce pulse trains with a desirable main-lobe-to-side-lobe ratio. In addition, coding can be used to reduce acquisition algorithm search space.

Coding methods for specifying temporal and non-temporal pulse characteristics are described in commonly owned, co-pending applications titled "A Method and Apparatus for Positioning Pulses in Time," Application No. 09/592,249, and "A Method for Specifying Non-Temporal Pulse Characteristics," Application No. 09/592,250, both filed June 12, 2000, and both of which are incorporated herein by reference.

Typically, a code consists of a number of code elements having integer or floating-point values. A code element value may specify a single pulse characteristic or may be subdivided into multiple components, each specifying a different pulse

characteristic. Code element or code component values typically map to a pulse characteristic value layout that may be fixed or non-fixed and may involve value ranges, discrete values, or a combination of value  
5 ranges and discrete values. A value range layout specifies a range of values that is divided into components that are each subdivided into subcomponents, which can be further subdivided, as desired. In contrast, a discrete value layout  
10 involves uniformly or non-uniformly distributed discrete values. A non-fixed layout (also referred to as a delta layout) involves delta values relative to some reference value. Fixed and non-fixed layouts, and approaches for mapping code element/component  
15 values, are described in co-owned, co-pending applications, titled "Method for Specifying Pulse Characteristics using Codes," Application No. 09/592,290 and "A Method and Apparatus for Mapping Pulses to a Non-Fixed Layout," Application No.  
20 09/591,691, both filed on June 12, 2000, both of which are incorporated herein by reference.

A fixed or non-fixed characteristic value layout may include a non-allowable region within which a pulse characteristic value is disallowed. A method  
25 for specifying non-allowable regions is described in co-owned, co-pending application titled "A Method for Specifying Non-Allowable Pulse Characteristics," Application No. 09/592,289, filed June 12, 2000, and incorporated herein by reference. A related method  
30 that conditionally positions pulses depending on whether code elements map to non-allowable regions is

described in co-owned, co-pending application, titled  
 "A Method and Apparatus for Positioning Pulses Using a  
 Layout having Non-Allowable Regions," Application No.  
 09/592,248 filed June 12, 2000, and incorporated  
 5 herein by reference.

The signal of a coded pulse train can be  
 generally expressed by:

$$s_{tr}^{(k)}(t) = \sum_j (-1)^{f_j^{(k)}} a_j^{(k)} \omega(c_j^{(k)}t - T_j^{(k)}, b_j^{(k)})$$

where  $k$  is the index of a transmitter,  $j$  is the index  
 10 of a pulse within its pulse train,  $(-1)^{f_j^{(k)}}$ ,  $a_j^{(k)}$ ,  
 $b_j^{(k)}$ ,  $c_j^{(k)}$ , and  $\omega(t, b_j^{(k)})$  are the coded polarity, pulse  
 amplitude, pulse type, pulse width, and normalized  
 pulse waveform of the  $j$ th pulse of the  $k$ th  
 transmitter, and  $T_j^{(k)}$  is the coded time shift of the  
 15  $j$ th pulse of the  $k$ th transmitter. Note: When a given  
 non-temporal characteristic does not vary (i.e.,  
 remains constant for all pulses), it becomes a  
 constant in front of the summation sign.

Various numerical code generation methods can be  
 20 employed to produce codes having certain correlation  
 and spectral properties. Such codes typically fall  
 into one of two categories: designed codes and  
 pseudorandom codes. A designed code may be generated  
 using a quadratic congruential, hyperbolic  
 25 congruential, linear congruential, Costas array, or  
 other such numerical code generation technique  
 designed to generate codes having certain correlation  
 properties. A pseudorandom code may be generated  
 using a computer's random number generator, binary

shift-register(s) mapped to binary words, a chaotic code generation scheme, or the like. Such 'random-like' codes are attractive for certain applications since they tend to spread spectral energy over multiple frequencies while having 'good enough' correlation properties, whereas designed codes may have superior correlation properties but possess less suitable spectral properties. Detailed descriptions of numerical code generation techniques are included in a co-owned, co-pending patent application titled "A Method and Apparatus for Positioning Pulses in Time," Application No. 09/592,248, filed June 12, 2000, and incorporated herein by reference.

It may be necessary to apply predefined criteria to determine whether a generated code, code family, or a subset of a code is acceptable for use with a given UWB application. Criteria may include correlation properties, spectral properties, code length, non-allowable regions, number of code family members, or other pulse characteristics. A method for applying predefined criteria to codes is described in co-owned, co-pending application, titled "A Method and Apparatus for Specifying Pulse Characteristics using a Code that Satisfies Predefined Criteria," Application No. 09/592,288, filed June 12, 2000, and incorporated herein by reference.

In some applications, it may be desirable to employ a combination of codes. Codes may be combined sequentially, nested, or sequentially nested, and code combinations may be repeated. Sequential code combinations typically involve switching from one code

to the next after the occurrence of some event and may also be used to support multicast communications. Nested code combinations may be employed to produce pulse trains having desirable correlation and spectral properties. For example, a designed code may be used to specify value range components within a layout and a nested pseudorandom code may be used to randomly position pulses within the value range components. With this approach, correlation properties of the designed code are maintained since the pulse positions specified by the nested code reside within the value range components specified by the designed code, while the random positioning of the pulses within the components results in particular spectral properties. A method for applying code combinations is described in co-owned, co-pending application, titled "A Method and Apparatus for Applying Codes Having Pre-Defined Properties," Application No. 09/591,690, filed June 12, 2000, and incorporated herein by reference.

20

### **Modulation**

Various aspects of a pulse waveform may be modulated to convey information and to further minimize structure in the resulting spectrum. Amplitude modulation, phase modulation, frequency modulation, time-shift modulation and M-ary versions of these were proposed in U.S. Patent No. 5,677,927 to Fullerton et al., previously incorporated by reference. Time-shift modulation can be described as shifting the position of a pulse either forward or backward in time relative to a nominal coded (or

30

uncoded) time position in response to an information signal. Thus, each pulse in a train of pulses is typically delayed a different amount from its respective time base clock position by an individual  
 5 code delay amount plus a modulation time shift. This modulation time shift is normally very small relative to the code shift. In a 10 Mpps system with a center frequency of 2 GHz, for example, the code may command pulse position variations over a range of 100 ns,  
 10 whereas, the information modulation may shift the pulse position by 150 ps. This two-state 'early-late' form of time shift modulation is depicted in Fig. 4A.

A pulse train with conventional 'early-late'  
 15 time-shift modulation can be expressed:

$$s_{tr}^{(k)}(t) = \sum_j (-1)^{f_j^{(k)}} a_j^{(k)} \omega(c_j^{(k)}t - T_j^{(k)} - \delta d_{[j/N_s]}^{(k)}, b_j^{(k)})$$

where  $k$  is the index of a transmitter,  $j$  is the index of a pulse within its pulse train,  $(-1)^{f_j^{(k)}}$ ,  $a_j^{(k)}$ ,  $b_j^{(k)}$ ,  $c_j^{(k)}$ , and  $\omega(t, b_j^{(k)})$  are the coded polarity, pulse  
 20 amplitude, pulse type, pulse width, and normalized pulse waveform of the  $j$ th pulse of the  $k$ th transmitter,  $T_j^{(k)}$  is the coded time shift of the  $j$ th pulse of the  $k$ th transmitter,  $\delta$  is the time shift added when the transmitted symbol is 1 (instead of 0),  
 25  $d^{(k)}$  is the data (i.e., 0 or 1) transmitted by the  $k$ th transmitter, and  $N_s$  is the number of pulses per symbol (e.g., bit). Similar expressions can be derived to accommodate other proposed forms of modulation.



An alternative form of time-shift modulation can be described as One-of-Many Position Modulation (OMPM). The OMPM approach, shown in Fig. 4B, involves shifting a pulse to one of  $N$  possible modulation positions about a nominal coded (or uncoded) time position in response to an information signal, where  $N$  represents the number of possible states. For example, if  $N$  were four (4), two data bits of information could be conveyed. For further details regarding OMPM, see "Apparatus, System and Method for One-of-Many Position Modulation in an Impulse Radio Communication System," Attorney Docket No. 1659.0860000, filed June 7, 2000, assigned to the assignee of the present invention, and incorporated herein by reference.

An impulse radio communications system can employ flip modulation techniques to convey information. The simplest flip modulation technique involves transmission of a pulse or an inverted (or flipped) pulse to represent a data bit of information, as depicted in Fig. 4C. Flip modulation techniques may also be combined with time-shift modulation techniques to create two, four, or more different data states. One such flip with shift modulation technique is referred to as Quadrature Flip Time Modulation (QFTM). The QFTM approach is illustrated in Fig. 4D. Flip modulation techniques are further described in patent application titled "Apparatus, System and Method for Flip Modulation in an Impulse Radio Communication System," Application No. 09/537,692, filed March 29,

2000, assigned to the assignee of the present invention, and incorporated herein by reference.

Vector modulation techniques may also be used to convey information. Vector modulation includes the steps of generating and transmitting a series of time-modulated pulses, each pulse delayed by one of at least four pre-determined time delay periods and representative of at least two data bits of information, and receiving and demodulating the series of time-modulated pulses to estimate the data bits associated with each pulse. Vector modulation is shown in Fig. 4E. Vector modulation techniques are further described in patent application titled "Vector Modulation System and Method for Wideband Impulse Radio Communications," Application No. 09/169,765, filed December 9, 1999, assigned to the assignee of the present invention, and incorporated herein by reference.

#### 20           **Reception and Demodulation**

Impulse radio systems operating within close proximity to each other may cause mutual interference. While coding minimizes mutual interference, the probability of pulse collisions increases as the number of coexisting impulse radio systems rises. Additionally, various other signals may be present that cause interference. Impulse radios can operate in the presence of mutual interference and other interfering signals, in part because they do not depend on receiving every transmitted pulse. Impulse radio receivers perform a correlating, synchronous

receiving function (at the RF level) that uses statistical sampling and combining, or integration, of many pulses to recover transmitted information. Typically, 1 to 1000 or more pulses are integrated to  
5 yield a single data bit thus diminishing the impact of individual pulse collisions, where the number of pulses that must be integrated to successfully recover transmitted information depends on a number of variables including pulse rate, bit rate, range and  
10 interference levels.

#### **Interference Resistance**

Besides providing channelization and energy smoothing, coding makes impulse radios highly  
15 resistant to interference by enabling discrimination between intended impulse transmissions and interfering transmissions. This property is desirable since impulse radio systems must share the energy spectrum with conventional radio systems and with other impulse  
20 radio systems. Fig. 5A illustrates the result of a narrow band sinusoidal interference signal 502 overlaying an impulse radio signal 504. At the impulse radio receiver, the input to the cross correlation would include the narrow band signal 502  
25 and the received ultrawide-band impulse radio signal 504. The input is sampled by the cross correlator using a template signal 506 positioned in accordance with a code. Without coding, the cross correlation would sample the interfering signal 502 with such  
30 regularity that the interfering signals could cause interference to the impulse radio receiver. However,

when the transmitted impulse signal is coded and the impulse radio receiver template signal 506 is synchronized using the identical code, the receiver samples the interfering signals non-uniformly. The samples from the interfering signal add incoherently, increasing roughly according to the square root of the number of samples integrated. The impulse radio signal samples, however, add coherently, increasing directly according to the number of samples integrated. Thus, integrating over many pulses overcomes the impact of interference.

#### 15            **Processing Gain**

Impulse radio systems have exceptional processing gain due to their wide spreading bandwidth. For typical spread spectrum systems, the definition of processing gain, which quantifies the decrease in channel interference when wide-band communications are used, is the ratio of the bandwidth of the channel to the bit rate of the information signal. For example, a direct sequence spread spectrum system with a 10 KHz information bandwidth and a 10 MHz channel bandwidth yields a processing gain of 1000, or 30 dB. However, far greater processing gains are achieved by impulse radio systems, where the same 10 KHz information bandwidth is spread across a much greater 2 GHz channel bandwidth, resulting in a theoretical processing gain of 200,000, or 53 dB.

### Capacity

It can be shown theoretically, using signal-to-noise arguments, that thousands of simultaneous channels are available to an impulse radio system as a result of its exceptional processing gain.

The average output signal-to-noise ratio of the impulse radio may be calculated for randomly selected time-hopping codes as a function of the number of active users,  $N_u$ , as:

$$SNR_{out}(N_u) = \frac{(N_s A_1 m_p)^2}{\sigma_{rec}^2 + N_s \sigma_a^2 \sum_{k=2}^{N_u} A_k^2}$$

where  $N_s$  is the number of pulses integrated per bit of information,  $A_k$  models the attenuation of transmitter  $k$ 's signal over the propagation path to the receiver, and  $\sigma_{rec}^2$  is the variance of the receiver noise component at the pulse train integrator output. The monocycle waveform-dependent parameters  $m_p$  and  $\sigma_a^2$  are given by

$$m_p = \int_{-\infty}^{\infty} \omega(t) [\omega(t) - \omega(t - \delta)] dt$$

and

$$\sigma_a^2 = T_f^{-1} \int_{-\infty}^{\infty} \left[ \int_{-\infty}^{\infty} \omega(t-s) v(t) dt \right]^2 ds,$$

where  $\omega(t)$  is the monocycle waveform,  $v(t) = \omega(t) - \omega(t - \delta)$  is the template signal waveform,  $\delta$  is the time shift between the monocycle waveform and the template signal waveform,  $T_f$  is the pulse repetition time, and  $s$  is signal.

25

### **Multipath and Propagation**

One of the advantages of impulse radio is its resistance to multipath fading effects. Conventional narrow band systems are subject to multipath through the Rayleigh fading process, where the signals from many delayed reflections combine at the receiver antenna according to their seemingly random relative phases resulting in possible summation or possible cancellation, depending on the specific propagation to a given location. Multipath fading effects are most adverse where a direct path signal is weak relative to multipath signals, which represents the majority of the potential coverage area of a radio system. In a mobile system, received signal strength fluctuates due to the changing mix of multipath signals that vary as its position varies relative to fixed transmitters, mobile transmitters and signal-reflecting surfaces in the environment.

Impulse radios, however, can be substantially resistant to multipath effects. Impulses arriving from delayed multipath reflections typically arrive outside of the correlation time and, thus, may be ignored. This process is described in detail with reference to Figs. 5B and 5C. Fig 5B illustrates a typical multipath situation, such as in a building, where there are many reflectors 504B, 505B. In this figure, a transmitter 506B transmits a signal that propagates along three paths, the direct path 501B, path 1 502B, and path2 503B, to a receiver 508B, where the multiple reflected signals are combined at the antenna. The direct path 501B, representing the

straight-line distance between the transmitter and receiver, is the shortest. Path 1 502B represents a multipath reflection with a distance very close to that of the direct path. Path 2 503B represents a  
5 multipath reflection with a much longer distance. Also shown are elliptical (or, in space, ellipsoidal) traces that represent other possible locations for reflectors that would produce paths having the same distance and thus the same time delay.

10 Fig. 5C illustrates the received composite pulse waveform resulting from the three propagation paths 501B, 502B, and 503B shown in Fig. 5B. In this figure, the direct path signal 501B is shown as the first pulse signal received. The path 1 and path 2  
15 signals 502B, 503B comprise the remaining multipath signals, or multipath response, as illustrated. The direct path signal is the reference signal and represents the shortest propagation time. The path 1 signal is delayed slightly and overlaps and enhances  
20 the signal strength at this delay value. The path 2 signal is delayed sufficiently that the waveform is completely separated from the direct path signal. Note that the reflected waves are reversed in polarity. If the correlator template signal is positioned such that  
25 it will sample the direct path signal, the path 2 signal will not be sampled and thus will produce no response. However, it can be seen that the path 1 signal has an effect on the reception of the direct path signal since a portion of it would also be  
30 sampled by the template signal. Generally, multipath signals delayed less than one quarter wave (one

quarter wave is about 1.5 inches, or 3.5cm at 2 GHz center frequency) may attenuate the direct path signal. This region is equivalent to the first Fresnel zone in narrow band systems. Impulse radio, however, has no further nulls in the higher Fresnel zones. This ability to avoid the highly variable attenuation from multipath gives impulse radio significant performance advantages.

Figs. 5D, 5E, and 5F represent the received signal from a TM-UWB transmitter in three different multipath environments. These figures are approximations of typical signal plots. Fig. 5D illustrates the received signal in a very low multipath environment. This may occur in a building where the receiver antenna is in the middle of a room and is a relatively short, distance, for example, one meter, from the transmitter. This may also represent signals received from a larger distance, such as 100 meters, in an open field where there are no objects to produce reflections. In this situation, the predominant pulse is the first received pulse and the multipath reflections are too weak to be significant. Fig. 5E illustrates an intermediate multipath environment. This approximates the response from one room to the next in a building. The amplitude of the direct path signal is less than in Fig. 5D and several reflected signals are of significant amplitude. Fig. 5F approximates the response in a severe multipath environment such as propagation through many rooms, from corner to corner in a building, within a metal cargo hold of a ship, within a metal truck trailer, or



within an intermodal shipping container. In this scenario, the main path signal is weaker than in Fig. 5E. In this situation, the direct path signal power is small relative to the total signal power from the  
5 reflections.

An impulse radio receiver can receive the signal and demodulate the information using either the direct path signal or any multipath signal peak having sufficient signal-to-noise ratio. Thus, the impulse  
10 radio receiver can select the strongest response from among the many arriving signals. In order for the multipath signals to cancel and produce a null at a given location, dozens of reflections would have to be cancelled simultaneously and precisely while blocking  
15 the direct path, which is a highly unlikely scenario. This time separation of multipath signals together with time resolution and selection by the receiver permit a type of time diversity that virtually eliminates cancellation of the signal. In a multiple  
20 correlator rake receiver, performance is further improved by collecting the signal power from multiple signal peaks for additional signal-to-noise performance.

Where the system of Fig. 5B is a narrow band  
25 system and the delays are small relative to the data bit time, the received signal is a sum of a large number of sine waves of random amplitude and phase. In the idealized limit, the resulting envelope amplitude has been shown to follow a Rayleigh  
30 probability distribution as follows:

$$p(r) = \frac{r}{\sigma^2} \exp\left(\frac{-r^2}{2\sigma^2}\right)$$

where  $r$  is the envelope amplitude of the combined multipath signals, and  $\sigma(2)^{1/2}$  is the RMS power of the combined multipath signals. The Rayleigh distribution curve in Fig. 5G shows that 10% of the time, the signal is more than 10 dB attenuated. This suggests that 10 dB fade margin is needed to provide 90% link availability. Values of fade margin from 10 to 40 dB have been suggested for various narrow band systems, depending on the required reliability. This characteristic has been the subject of much research and can be partially improved by such techniques as antenna and frequency diversity, but these techniques result in additional complexity and cost.

In a high multipath environment such as inside homes, offices, warehouses, automobiles, trailers, shipping containers, or outside in an urban canyon or other situations where the propagation is such that the received signal is primarily scattered energy, impulse radio systems can avoid the Rayleigh fading mechanism that limits performance of narrow band systems, as illustrated in Fig. 5H and 5I. Fig. 5H depicts an impulse radio system in a high multipath environment 500H consisting of a transmitter 506H and a receiver 508H. A transmitted signal follows a direct path 501H and reflects off reflectors 503H via multiple paths 502H. Fig. 5I illustrates the combined signal received by the receiver 508H over time with the vertical axis being signal strength in volts and

the horizontal axis representing time in nanoseconds. The direct path 501H results in the direct path signal 502I while the multiple paths 502H result in multipath signals 504I. In the same manner described earlier  
5 for Figs. 5B and 5C, the direct path signal 502I is sampled, while the multipath signals 504I are not, resulting in Rayleigh fading avoidance.

### **Distance Measurement and Positioning**

10 Impulse systems can measure distances to relatively fine resolution because of the absence of ambiguous cycles in the received waveform. Narrow band systems, on the other hand, are limited to the modulation envelope and cannot easily distinguish  
15 precisely which RF cycle is associated with each data bit because the cycle-to-cycle amplitude differences are so small they are masked by link or system noise. Since an impulse radio waveform has no multi-cycle ambiguity, it is possible to determine waveform  
20 position to less than a wavelength, potentially down to the noise floor of the system. This time position measurement can be used to measure propagation delay to determine link distance to a high degree of precision. For example, 30 ps of time transfer  
25 resolution corresponds to approximately centimeter distance resolution. See, for example, U.S. Patent No. 6,133,876, issued October 17, 2000, titled "System and Method for Position Determination by Impulse Radio," and U.S. Patent No. 6,111,536, issued August  
30 29, 2000, titled "System and Method for Distance Measurement by Inphase and Quadrature Signals in a

Radio System," both of which are incorporated herein by reference.

In addition to the methods articulated above, impulse radio technology along with Time Division  
5 Multiple Access algorithms and Time Domain packet radios can achieve geo-positioning capabilities in a radio network. This geo-positioning method is described in co-owned, co-pending application titled  
"System and Method for Person or Object Position  
10 Location Utilizing Impulse Radio," Application No. 09/456,409, filed December 8, 1999, and incorporated herein by reference.

#### **Power Control**

15 Power control systems comprise a first transceiver that transmits an impulse radio signal to a second transceiver. A power control update is calculated according to a performance measurement of the signal received at the second transceiver. The  
20 transmitter power of either transceiver, depending on the particular setup, is adjusted according to the power control update. Various performance measurements are employed to calculate a power control update, including bit error rate, signal-to-noise ratio, and  
25 received signal strength, used alone or in combination. Interference is thereby reduced, which may improve performance where multiple impulse radios are operating in close proximity and their transmissions interfere with one another. Reducing  
30 the transmitter power of each radio to a level that produces satisfactory reception increases the total

number of radios that can operate in an area without saturation. Reducing transmitter power also increases transceiver efficiency.

For greater elaboration of impulse radio power control, see patent application titled "System and Method for Impulse Radio Power Control," Application No. 09/332,501, filed June 14, 1999, assigned to the assignee of the present invention, and incorporated herein by reference.

10

#### **Mitigating Effects of Interference**

A method for mitigating interference in impulse radio systems comprises the steps of conveying the message in packets, repeating conveyance of selected packets to make up a repeat package, and conveying the repeat package a plurality of times at a repeat period greater than twice the period of occurrence of the interference. The communication may convey a message from a proximate transmitter to a distal receiver, and receive a message by a proximate receiver from a distal transmitter. In such a system, the method comprises the steps of providing interference indications by the distal receiver to the proximate transmitter, using the interference indications to determine predicted noise periods, and operating the proximate transmitter to convey the message according to at least one of the following: (1) avoiding conveying the message during noise periods, (2) conveying the message at a higher power during noise periods, (3) increasing error detection coding in the message during noise periods, (4) re-transmitting the

20  
25  
30

message following noise periods, (5) avoiding conveying the message when interference is greater than a first strength, (6) conveying the message at a higher power when the interference is greater than a second strength, (7) increasing error detection coding in the message when the interference is greater than a third strength, and (8) re-transmitting a portion of the message after interference has subsided to less than a predetermined strength.

10 For greater elaboration of mitigating interference in impulse radio systems, see the patent application titled "Method for Mitigating Effects of Interference in Impulse Radio Communication," Application No. 09/587,033, filed June 02, 1999, 15 assigned to the assignee of the present invention, and incorporated herein by reference.

#### **Moderating Interference in Equipment Control Applications**

20 Yet another improvement to impulse radio includes moderating interference with impulse radio wireless control of an appliance. The control is affected by a controller remote from the appliance which transmits impulse radio digital control signals to the 25 appliance. The control signals have a transmission power and a data rate. The method comprises the steps of establishing a maximum acceptable noise value for a parameter relating to interfering signals and a frequency range for measuring the interfering signals, 30 measuring the parameter for the interference signals within the frequency range, and effecting an

alteration of transmission of the control signals when the parameter exceeds the maximum acceptable noise value.

For greater elaboration of moderating interference while effecting impulse radio wireless control of equipment, see patent application titled "Method and Apparatus for Moderating Interference While Effecting Impulse Radio Wireless Control of Equipment," Application No. 09/586,163, filed June 2, 1999, and assigned to the assignee of the present invention, and incorporated herein by reference.

### **Exemplary Transceiver Implementation**

#### **15 Transmitter**

An exemplary embodiment of an impulse radio transmitter 602 of an impulse radio communication system having an optional subcarrier channel will now be described with reference to Fig. 6.

20 The transmitter 602 comprises a time base 604 that generates a periodic timing signal 606. The time base 604 typically comprises a voltage controlled oscillator (VCO), or the like, having a high timing accuracy and low jitter, on the order of picoseconds (ps). The control voltage to adjust the VCO center frequency is set at calibration to the desired center frequency used to define the transmitter's nominal pulse repetition rate. The periodic timing signal 606 is supplied to a precision timing generator 608.

30 The precision timing generator 608 supplies synchronizing signals 610 to the code source 612 and

utilizes the code source output 614, together with an optional, internally generated subcarrier signal, and an information signal 616, to generate a modulated, coded timing signal 618.

5           An information source 620 supplies the information signal 616 to the precision timing generator 608. The information signal 616 can be any type of intelligence, including digital bits representing voice, data, imagery, or the like, analog  
10 signals, or complex signals.

A pulse generator 622 uses the modulated, coded timing signal 618 as a trigger signal to generate output pulses. The output pulses are provided to a transmit antenna 624 via a transmission line 626  
15 coupled thereto. The output pulses are converted into propagating electromagnetic pulses by the transmit antenna 624. The electromagnetic pulses are called the emitted signal, and propagate to an impulse radio receiver 702, such as shown in Fig. 7, through a  
20 propagation medium. In a preferred embodiment, the emitted signal is wide-band or ultrawide-band, approaching a monocycle pulse as in Fig. 1B. However, the emitted signal may be spectrally modified by filtering of the pulses, which may cause them to have  
25 more zero crossings (more cycles) in the time domain, requiring the radio receiver to use a similar waveform as the template signal for efficient conversion.

30           **Receiver**



An exemplary embodiment of an impulse radio receiver (hereinafter called the receiver) for the impulse radio communication system is now described with reference to Fig. 7.

5       The receiver 702 comprises a receive antenna 704 for receiving a propagated impulse radio signal 706. A received signal 708 is input to a cross correlator or sampler 710, via a receiver transmission line, coupled to the receive antenna 704. The cross correlation 710  
10 produces a baseband output 712.

      The receiver 702 also includes a precision timing generator 714, which receives a periodic timing signal 716 from a receiver time base 718. This time base 718 may be adjustable and controllable in time, frequency,  
15 or phase, as required by the lock loop in order to lock on the received signal 708. The precision timing generator 714 provides synchronizing signals 720 to the code source 722 and receives a code control signal 724 from the code source 722. The precision timing  
20 generator 714 utilizes the periodic timing signal 716 and code control signal 724 to produce a coded timing signal 726. The template generator 728 is triggered by this coded timing signal 726 and produces a train of template signal pulses 730 ideally having waveforms  
25 substantially equivalent to each pulse of the received signal 708. The code for receiving a given signal is the same code utilized by the originating transmitter to generate the propagated signal. Thus, the timing of the template pulse train matches the timing of the  
30 received signal pulse train, allowing the received signal 708 to be synchronously sampled in the

correlator 710. The correlator 710 preferably comprises a multiplier followed by a short term integrator to sum the multiplier product over the pulse interval.

5 The output of the correlator 710 is coupled to a subcarrier demodulator 732, which demodulates the subcarrier information signal from the optional subcarrier. The purpose of the optional subcarrier process, when used, is to move the information signal  
10 away from DC (zero frequency) to improve immunity to low frequency noise and offsets. The output of the subcarrier demodulator is then filtered or integrated in the pulse summation stage 734. A digital system embodiment is shown in Fig. 7. In this digital  
15 system, a sample and hold 736 samples the output 735 of the pulse summation stage 734 synchronously with the completion of the summation of a digital bit or symbol. The output of sample and hold 736 is then compared with a nominal zero (or reference) signal  
20 output in a detector stage 738 to provide an output signal 739 representing the digital state of the output voltage of sample and hold 736.

The baseband signal 712 is also input to a lowpass filter 742 (also referred to as lock loop  
25 filter 742). A control loop comprising the lowpass filter 742, time base 718, precision timing generator 714, template generator 728, and correlator 710 is used to generate an error signal 744. The error signal 744 provides adjustments to the adjustable time  
30 base 718 to position in time the periodic timing

signal 726 in relation to the position of the received signal 708.

In a transceiver embodiment, substantial economy can be achieved by sharing part or all of several of the functions of the transmitter 602 and receiver 702. Some of these include the time base 718, precision timing generator 714, code source 722, antenna 704, and the like.

FIGS. 8A-8C illustrate the cross correlation process and the correlation function. Fig. 8A shows the waveform of a template signal. Fig. 8B shows the waveform of a received impulse radio signal at a set of several possible time offsets. Fig. 8C represents the output of the cross correlator for each of the time offsets of Fig. 8B. For any given pulse received, there is a corresponding point that is applicable on this graph. This is the point corresponding to the time offset of the template signal used to receive that pulse. Further examples and details of precision timing can be found described in U.S. Patent 5,677,927, and commonly owned co-pending application Application No. 09/146,524, filed September 3, 1998, titled "Precision Timing Generator System and Method," both of which are incorporated herein by reference.

Because of the unique nature of impulse radio receivers, several modifications have been recently made to enhance system capabilities. Modifications include the utilization of multiple correlators to measure the impulse response of a channel to the maximum communications range of the system and to

capture information on data symbol statistics. Further, multiple correlators enable rake pulse correlation techniques, more efficient acquisition and tracking implementations, various modulation schemes, and collection of time-calibrated pictures of received waveforms. For greater elaboration of multiple correlator techniques, see patent application titled "System and Method of using Multiple Correlator Receivers in an Impulse Radio System", Application No. 09/537,264, filed March 29, 2000, assigned to the assignee of the present invention, and incorporated herein by reference.

Methods to improve the speed at which a receiver can acquire and lock onto an incoming impulse radio signal have been developed. In one approach, a receiver includes an adjustable time base to output a sliding periodic timing signal having an adjustable repetition rate and a decode timing modulator to output a decode signal in response to the periodic timing signal. The impulse radio signal is cross-correlated with the decode signal to output a baseband signal. The receiver integrates  $T$  samples of the baseband signal and a threshold detector uses the integration results to detect channel coincidence. A receiver controller stops sliding the time base when channel coincidence is detected. A counter and extra count logic, coupled to the controller, are configured to increment or decrement the address counter by one or more extra counts after each  $T$  pulses is reached in order to shift the code modulo for proper phase alignment of the periodic timing signal and the

received impulse radio signal. This method is described in more detail in U.S. Patent No. 5,832,035 to Fullerton, incorporated herein by reference.

In another approach, a receiver obtains a  
5 template pulse train and a received impulse radio signal. The receiver compares the template pulse train and the received impulse radio signal. The system performs a threshold check on the comparison result. If the comparison result passes the threshold  
10 check, the system locks on the received impulse radio signal. The system may also perform a quick check, a synchronization check, and/or a command check of the impulse radio signal. For greater elaboration of this approach, see the patent application titled "Method  
15 and System for Fast Acquisition of Ultra Wideband Signals," Application No. 09/538,292, filed March 29, 2000, assigned to the assignee of the present invention, and incorporated herein by reference.

A receiver has been developed that includes a  
20 baseband signal converter device and combines multiple converter circuits and an RF amplifier in a single integrated circuit package. For greater elaboration of this receiver, see the patent application titled "Baseband Signal Converter for a Wideband Impulse  
25 Radio Receiver," Application No. 09/356,384, filed July 16, 1999, assigned to the assignee of the present invention, and incorporated herein by reference.

#### **PREFERRED EMBODIMENTS OF THE PRESENT INVENTION**

30 Referring to FIGS. 9-22, there are disclosed six embodiments of an exemplary railroad collision

avoidance system 900 and preferred method 1000 in accordance with the present invention.

Referring to FIGS. 9 and 10, there are a block diagram illustrating the basic components of the railroad collision avoidance system 900 and a flowchart illustrating the basic steps of a preferred method 1000. Basically, the railroad collision avoidance system 900 includes a transmitting impulse radio unit 902 (see impulse radio transmitter 602 of FIG. 6) and a receiving impulse radio unit 904 (see impulse radio receiver 702 of FIG. 7). The transmitting impulse radio unit 902 can be coupled (step 1002) to a first object 906 such as a locomotive or a control box that is located next to railroad tracks and is capable of sensing the presence of a locomotive. And, the receiving impulse radio unit 904 can be coupled (step 1004) to a second object 908 such as a vehicle, railroad pole, work vehicle or another locomotive.

In operation, the transmitting impulse radio unit 902 is capable of transmitting (step 1006) an impulse radio signal 910 towards the receiving impulse radio unit 904 and the second object 908 when there is a potentially dangerous situation such as when a moving locomotive is in the vicinity of the second object 908. Upon receiving (step 1008) the impulse radio signal 910, the receiving impulse radio unit 904 makes sure a person associated with the second object 908 is informed (step 1010) about the potentially dangerous situation. As will be described in greater detail below with respect to the different embodiments of the

present invention, the railroad collision avoidance system 900 can utilize on one chip the revolutionary position capabilities, radar capabilities and/or communication capabilities of impulse radio  
5 technology.

Referring to FIGS. 11 and 12, there are diagrams illustrating in greater detail the components and steps of a first embodiment of the railroad collision avoidance system 900a and method 1000a. In this  
10 embodiment, the railroad collision avoidance system 900 includes a transmitting impulse radio unit 902 coupled (step 1202) to a locomotive 1102 and a receiving impulse radio unit 904 coupled (step 1204) to a vehicle 1104 (shown as a car). The transmitting  
15 impulse radio unit 902 operates to transmit (step 1206) an impulse radio signal 910 having a known pseudorandom sequence of pulses that look like a series of Gaussian waveforms (see FIGS. 1-3) towards the receiving impulse radio unit 904 attached to the  
20 vehicle 1104. In particular, the transmitting impulse radio unit 902 may continually transmit the impulse radio signal 910 or it may transmit the impulse radio signal 910 whenever a whistle (for example) on the locomotive 1102 is activated to indicate that the  
25 locomotive 1102 is a predetermined distance from a railroad crossing 1106 (shown as a passive railroad crossing without a railroad pole).

Upon receiving (step 1208) the impulse radio signal 910, the receiving impulse radio unit 902 makes  
30 sure that the person operating the vehicle 1104 is alerted (step 1210) about the potentially dangerous

situation. For instance, the receiving impulse radio unit 902 may be incorporated within or coupled to an after-market display 1108a (showing the receiving impulse radio unit 902) or an in-dash display 1108b  
5 (not showing the receiving impulse radio unit 902). Either display 1108a or 1108b is capable of alerting a person that there is a locomotive 1102 in their vicinity by generating an alarm (see light 1112) or voice message (see speaker 1114). Moreover, a person  
10 could use the display 1108 having a transmitting impulse radio unit (not shown) to communicate with a person on the locomotive having a receiving impulse radio unit (not shown).

In addition, either display 1108a and 1108b is  
15 capable of showing (step 1212) the direction, distance and/or speed of the oncoming locomotive 1102. To determine the distance that the locomotive 1102 is from the vehicle 1104, a controller 1110 within the receiving impulse unit 904 can use the revolutionary  
20 positioning capabilities of impulse radio technology. In particular, the impulse radio signal 910 transmitted between the transmitting impulse radio unit 902 and the receiving impulse radio unit 904 enables the controller 1110 to measure distances to  
25 extremely fine resolution because of the absence of ambiguous cycles in the waveform of the impulse radio signal 910. In contrast, narrow band systems of traditional communication systems are limited to the modulation envelope and cannot easily distinguish  
30 precisely which RF cycle is associated with each data bit because the cycle-to-cycle amplitude differences



are so small they are masked by link or system noise. Since the waveform of the impulse radio signal 910 does not have multi-cycle ambiguity, this allows the controller 1110 to positively determine the position  
5 of the waveform to less than a wavelength even when the waveform is in or near the noise floor of the system. The time position measurement can be used by the controller 1110 to measure the propagation delay and determine the link distance between the receiving  
10 impulse radio unit 902 and the locomotive 1102. Once, the distance is known and updated then the speed of the locomotive 1102 can be determined by the controller 1110.

Referring to FIGS. 13 and 14, there are diagrams  
15 illustrating in greater detail the components and steps of a second embodiment of the railroad collision avoidance system 900b and method 1000b. In this embodiment, the railroad collision avoidance system 900b includes a transmitting impulse radio unit 902  
20 coupled (step 1402) to a locomotive 1102 and a receiving impulse radio unit 904 coupled (step 1404) to an active railroad pole 1302. The transmitting impulse radio unit 902 operates to transmit (step 1406) an impulse radio signal 910 having a known  
25 pseudorandom sequence of pulses that look like a series of Gaussian waveforms (see FIGS. 1-3) towards the receiving impulse radio unit 904 attached to the railroad pole 1302 (two are shown). In particular, the transmitting impulse radio unit 902 may  
30 continually transmit the impulse radio signal 910 or it may transmit the impulse radio signal 910 whenever

a whistle (for example) on the locomotive 1302 is activated to indicate that the locomotive 1302 is about to pass through a railroad crossing 1304 (shown as an active railroad crossing).

5        Upon receiving (step 1408) the impulse radio signal 910, the receiving impulse radio unit 902 interacts with a controller 1306 (shown inside the receiving impulse radio unit 902) on the railroad pole 1302 which makes sure that the person operating a  
10        vehicle 1308 is alerted (step 1410) about the potentially dangerous situation. For instance, the controller 1306 can trigger a warning light 1310 or a retractable gate 1312 to warn a person within the vehicle 1104 that there is a locomotive 1102  
15        approaching the railroad crossing 1304. Alternatively, the warning light 1310 may be solar powered and located on a railroad pole 1510 that would traditionally be associated with a passive railroad crossing (see FIG. 15). It should be understood that  
20        any vehicles 1308 that include the receiving impulse radio units 904 as described above with respect to FIG. 11 would also operate in this embodiment.

      In addition, the receiving impulse radio unit 904 may utilize the radar capability of impulse radio  
25        technology to send impulse radio signals 1313 and possibly receive reflected radio signals 1313 in order to scan (step 1412) the railroad crossing 1304 to determine whether a disabled vehicle 1314 is located on the tracks of the railroad crossing 1314. If there  
30        is a disabled vehicle 1114, then the receiving impulse radio unit 904 can communicate with the transmitting

impulse radio unit 902 to inform (step 1414) a person on the locomotive 1102 about the disabled vehicle 1314.

Referring to FIGS. 15 and 16, there are diagrams illustrating in greater detail the components and steps of a third embodiment of the railroad collision avoidance system 900c and method 1000c. In this embodiment, the railroad collision avoidance system 900c includes a transmitting impulse radio unit 902 coupled (step 1602) to a control box 1502 and a receiving impulse radio unit 904 coupled (step 1604) to a vehicle 1104. The control box 1502 is located next to railroad tracks 1504 and is capable of using a sensor 1506 (e.g., electromagnetic sensor, motion detector, percussion sensor) to sense the presence of a locomotive 1102. Moreover, the control box 1502 can be powered by a variety of power sources including, for example, a solar battery or a power line.

The transmitting impulse radio unit 902 operates to transmit an impulse radio signal 910 having a known pseudorandom sequence of pulses that look like a series of Gaussian waveforms (see FIGS. 1-3) towards the receiving impulse radio unit 904 attached to the vehicle 1104. In particular, the transmitting impulse radio unit 902 may transmit the impulse radio signal 910 when the sensor 1506 detects the presence of the locomotive 1102 near a railroad crossing 1508 (shown as a passive railroad crossing with a railroad pole 1510).

Upon receiving (step 1608) the impulse radio signal 910, the receiving impulse radio unit 902 makes

sure that the person operating the vehicle 1104 is alerted (step 1610) about the potentially dangerous situation. For instance, the receiving impulse radio unit 902 may be incorporated within or coupled to an after-market display 1108a (showing the receiving impulse radio unit 902) or an in-dash display 1108b (not showing the receiving impulse radio unit 902). Either display 1108a or 1108b is capable of alerting a person that there is a locomotive 1102 in their vicinity by generating an alarm (see light 1112) or voice message (see speaker 1114). Moreover, a person could use the display 1108 having a transmitting impulse radio unit (not shown) to communicate with a person on the locomotive having a receiving impulse radio unit (not shown).

In addition, either display 1108a or 1108b is capable of showing (step 1612) the direction, distance and/or speed of the oncoming locomotive 1102. To determine the distance that the locomotive 1302 is from vehicle 1104, a controller 1110 within the receiving impulse unit 904 can use the revolutionary positioning capabilities of impulse radio technology. In particular, the impulse radio signal 910 transmitted between the transmitting impulse radio unit 902 and the receiving impulse radio unit 904 enables the controller 1110 to measure distances to extremely fine resolution because of the absence of ambiguous cycles in the waveform of the impulse radio signal 910. In contrast, narrow band systems of traditional communication systems are limited to the modulation envelope and cannot easily distinguish

precisely which RF cycle is associated with each data bit because the cycle-to-cycle amplitude differences are so small they are masked by link or system noise. Since the waveform of the impulse radio signal 910 does not have multi-cycle ambiguity, this allows the controller 1110 to positively determine the position of the waveform to less than a wavelength even when the waveform is in or near the noise floor of the system. The time position measurement can be used by the controller 1110 to measure the propagation delay and determine the link distance between the receiving impulse radio unit 902 and the locomotive 1102. Once, the distance is known and updated then the speed of the locomotive 1102 can be determined by the controller 1110.

Referring to FIGS. 17 and 18, there are diagrams illustrating in greater detail the components and steps of a fourth embodiment of the railroad collision avoidance system 900d and method 1000d. In this embodiment, the railroad collision avoidance system 900d includes a transmitting impulse radio unit 902 coupled (step 1802) to a control box 1502 and a receiving impulse radio unit 904 coupled (step 1804) to a railroad pole 1302. The control box 1502 is located next to railroad tracks 1504 and is capable of using a sensor 1506 (e.g., electromagnetic sensor, motion detector, percussion sensor) to sense the presence of a locomotive 1102. Moreover, the control box 1502 can be powered by a variety of power sources including, for example, a solar battery or a power line.

The transmitting impulse radio unit 902 operates to transmit (step 1806) an impulse radio signal 910 having a known pseudorandom sequence of pulses that look like a series of Gaussian waveforms (see FIGS. 1-  
5 3) towards the receiving impulse radio unit 904 attached to railroad pole 1302. In particular, the transmitting impulse radio unit 902 may transmit the impulse radio signal 910 when the sensor 1506 detects the presence of the locomotive 1102 near a railroad  
10 crossing 1304 (shown as an active railroad crossing).

Upon receiving (step 1806) the impulse radio signal 910, the receiving impulse radio unit 902 interacts with a controller 1306 (shown inside the receiving impulse radio unit 902) on the railroad pole  
15 1302 which makes sure that the person operating the vehicle 1308 is alerted (step 1810) about the potentially dangerous situation. For instance, the controller 1306 can trigger a warning light 1310 or a retractable gate 1312 to warn a person within the  
20 vehicle 1308 that there is a locomotive 1102 approaching the railroad crossing 1304. Alternatively, the warning light 1310 may be solar powered and located on a railroad pole 1510 that would traditionally be associated with a passive railroad  
25 crossing (see FIG. 15). It should be understood that any vehicles 1104 that include the receiving impulse radio units 904 as described above with respect to FIG. 11 would also operate in this embodiment.

In addition, the receiving impulse radio unit 904  
30 may utilize the radar capability of impulse radio technology to send impulse radio signals 1313 and

possibly receive reflected radio signals 1313 in order to scan (step 1812) the railroad crossing 1304 to determine whether a disabled vehicle 1314 is located on the tracks of the railroad crossing 1304. If there  
5 is a disabled vehicle 1314, then the receiving impulse radio unit 904 can communicate with the transmitting impulse radio unit 902 to inform (step 1814) a person on the locomotive 1102 about the disabled vehicle 1314.

10 Referring to FIGS. 19 and 20, there are diagrams illustrating in greater detail the components and steps of a fifth embodiment of the railroad collision avoidance system 900e and method 1000e. In this embodiment, the railroad collision avoidance system  
15 900e includes a transmitting impulse radio unit 902 coupled (step 2002) to a locomotive 1102 and a receiving impulse radio unit 904 coupled (step 2004) to a work vehicle 1902. Since the locomotive 1102 would normally not be aware of the presence of the  
20 work vehicle 1902 on the same railroad tracks 1904, the transmitting impulse radio unit 902 may continually transmit (step 2006) an impulse radio signal 910. As described above, the impulse radio signal 910 has a known pseudorandom sequence of pulses  
25 that look like a series of Gaussian waveforms (see FIGS. 1-3).

Upon receiving (step 2008) the impulse radio signal 910, the receiving impulse radio unit 902 makes sure that the person operating the work vehicle 1902  
30 is alerted (step 2010) about the potentially dangerous situation. For instance, the receiving impulse radio

unit 902 may be incorporated within or coupled to an after-market display 1108a (showing the receiving impulse radio unit 902) or an in-dash display 1108b (not showing the receiving impulse radio unit 902).  
5 Either display 1108a or 1108b is capable of alerting a person that there is a locomotive 1102 in their vicinity by generating an alarm (see light 1112) or voice message (see speaker 1114). Moreover, a person could use the display 1108 having a transmitting  
10 impulse radio unit (not shown) to communicate with a person on the locomotive having a receiving impulse radio unit (not shown).

In addition, either display 1108a or 1108b is capable of showing (step 2012) the direction, distance  
15 and/or speed of the oncoming locomotive 1102. To determine the distance that the locomotive 1102 is from the work vehicle 1902, a controller 1110 within the receiving impulse unit 904 can use the revolutionary positioning capabilities of impulse  
20 radio technology. In particular, the impulse radio signal 910 transmitted between the transmitting impulse radio unit 902 and the receiving impulse radio unit 904 enables the controller 1110 to measure distances to extremely fine resolution because of the  
25 absence of ambiguous cycles in the waveform of the impulse radio signal 910. In contrast, narrow band systems of traditional communication systems are limited to the modulation envelope and cannot easily distinguish precisely which RF cycle is associated  
30 with each data bit because the cycle-to-cycle amplitude differences are so small they are masked by



link or system noise. Since the waveform of the impulse radio signal 910 does not have multi-cycle ambiguity, this allows the controller 1110 to positively determine the position of the waveform to less than a wavelength even when the waveform is in or near the noise floor of the system. The time position measurement can be used by the controller 1110 to measure the propagation delay and determine the link distance between the receiving impulse radio unit 902 and the locomotive 1102. Once, the distance is known and updated then the speed of the locomotive 1102 can be determined by the controller 1110.

Referring to FIGS. 21 and 22, there are diagrams illustrating in greater detail the components and steps of a sixth embodiment of the railroad collision avoidance system 900f and method 1000f. In this embodiment, the railroad collision avoidance system 900f includes a transmitting impulse radio unit 902 coupled (step 2202) to a first locomotive 1102 and a receiving impulse radio unit 904 coupled (step 2204) to a second locomotive 2102. Since neither of the locomotives 1102 and 2102 would normally be aware of each others presence on the same railroad track 2104, the transmitting impulse radio unit 902 would continually transmit (step 2206) an impulse radio signal 910. As described above, the impulse radio signal 910 has a known pseudorandom sequence of pulses that look like a series of Gaussian waveforms (see FIGS. 1-3).

Upon receiving (step 2206) the impulse radio signal 910 at the second locomotive 2102, the

receiving impulse radio unit 902 makes sure that a person operating the second locomotive 2102 is alerted (step 2208) about the presence of the first locomotive 1702. For instance, the receiving impulse radio unit 5 902 may be incorporated within or coupled to an after-market display 1108a (showing the receiving impulse radio unit 902) or an in-dash display 1108b (not showing the receiving impulse radio unit 902). Either display 1108a or 1108b is capable of alerting a 10 person that there is a locomotive 1102 in their vicinity by generating an alarm (see light 1112) or voice message (see speaker 1114). Moreover, a person could use the display 1108 having a transmitting impulse radio unit (not shown) to communicate with a 15 person on the locomotive having a receiving impulse radio unit (not shown).

In addition, either display 1108a or 1108b is capable of showing (step 2210) the direction, distance and/or speed of the oncoming first locomotive 1102. 20 To determine the distance that the first locomotive 1702 is from the second locomotive 2102, a controller 1110 within the receiving impulse unit 904 can use the revolutionary positioning capabilities of impulse radio technology. In particular, the impulse radio 25 signal 910 transmitted between the transmitting impulse radio unit 902 and the receiving impulse radio unit 904 enables the controller 1110 to measure distances to extremely fine resolution because of the absence of ambiguous cycles in the waveform of the 30 impulse radio signal 910. In contrast, narrow band systems of traditional communication systems are

limited to the modulation envelope and cannot easily distinguish precisely which RF cycle is associated with each data bit because the cycle-to-cycle amplitude differences are so small they are masked by link or system noise. Since the waveform of the impulse radio signal 910 does not have multi-cycle ambiguity, this allows the controller 1110 to positively determine the position of the waveform to less than a wavelength even when the waveform is in or near the noise floor of the system. The time position measurement can be used by the controller 1110 to measure the propagation delay and determine the link distance between the receiving impulse radio unit 902 and the locomotive 1102. Once, the distance is known and updated then the speed of the first locomotive 1102 can be determined by the controller 1110.

It should be understood that the first locomotive 1102 can contain the same equipment as the second locomotive 2102 (or other objects 908) and as such could be notified of the presence and speed of an oncoming second locomotive 2102 (or other objects 908).

It should also be understood that the present invention and impulse radio technology can be used in subway (underground) applications the same way it is used in railroad applications. Impulse radio technology is well suited for subway (underground) applications because this technology can effectively transmit and receive impulse radio signals through the ground.

Although several embodiments of the present invention have been illustrated in the accompanying Drawings and described in the foregoing Detailed Description, it should be understood that the  
5 invention is not limited to the embodiments disclosed, but is capable of numerous rearrangements, modifications and substitutions without departing from the spirit of the invention as set forth and defined by the following claims.

10

**WHAT IS CLAIMED IS:**

1. A railroad collision avoidance system comprising:

5 a transmitting impulse radio unit, coupled to a first object, capable of transmitting an impulse radio signal when there is a potentially dangerous situation on a railroad; and

10 a receiving impulse radio unit, coupled to a second object, capable of receiving the impulse radio signal and further capable of alerting a person about the potentially dangerous situation.

2. The railroad collision avoidance system of Claim 1, wherein the first object is a locomotive and  
15 the second object is a vehicle, whereby said receiving impulse radio unit receives the impulse radio signal at the vehicle when the locomotive is in the vicinity of a railroad crossing.

20 3. The railroad collision avoidance system of Claim 1, wherein said first object is a locomotive and the second object is a railroad pole, whereby said receiving impulse radio unit receives the impulse radio signal at the railroad pole when the locomotive  
25 is in the vicinity of a railroad crossing.

4. The railroad collision avoidance system of Claim 3, wherein said receiving impulse radio unit scans the railroad crossing to determine whether a  
30 vehicle is located on the railroad crossing and if yes

then a person on the locomotive is informed about the vehicle.

5        5.    The railroad collision avoidance system of Claim 1, wherein the first object is a control box and the second object is a vehicle, whereby said transmitting impulse radio unit transmits the impulse radio signal towards the vehicle when the control box learns of the presence of a locomotive.

10

6.    The railroad collision avoidance system of Claim 1, wherein said first object is a control box and the second object is a railroad pole, whereby said transmitting impulse radio unit transmits the impulse radio signal towards the railroad pole when the control box learns of the presence of a locomotive.

15

7.    The railroad collision avoidance system of Claim 6, wherein said receiving impulse radio unit scans the railroad crossing to determine whether a vehicle is located on the railroad crossing and if yes then a person on the locomotive is informed about the vehicle.

20

8.    The railroad collision avoidance system of Claim 1, wherein said first object is a locomotive and the second object is a work vehicle, whereby said receiving impulse radio unit receives the impulse radio signal at the work vehicle when the locomotive is in the vicinity of the work vehicle.

25

30

9. The railroad collision avoidance system of Claim 1, wherein said first object is a first locomotive and the second object is a second locomotive, whereby said receiving impulse radio unit  
5 receives the impulse radio signal at the second locomotive when the first locomotive is in the vicinity of the second locomotive.

10. The railroad collision avoidance system of  
10 Claim 1, wherein said receiving impulse radio unit is capable of determining a distance between a locomotive carrying the transmitting impulse radio unit and said receiving impulse radio unit.

15 11. A method for preventing train accidents, said method comprising the steps of:

transmitting an impulse radio signal from a transmitting impulse radio unit coupled to a first object when there is a potentially dangerous situation  
20 on a railroad;

receiving the impulse radio signal at a receiving impulse radio unit coupled to a second object; and

alerting a person about the potentially dangerous situation.

25

12. The method of Claim 11, wherein the first object is a locomotive, the second object is a vehicle and said step of receiving further includes receiving the impulse radio signal at the vehicle when the  
30 locomotive is in the vicinity of a railroad crossing.

13. The method of Claim 11, wherein said first object is a locomotive, the second object is a railroad pole and said step of receiving further includes receiving the impulse radio signal at the  
5 railroad pole when the locomotive is in the vicinity of a railroad crossing.

14. The method of Claim 13, further comprising the steps of:  
10 scanning the railroad crossing to determine whether a vehicle is located on the railroad crossing; and  
informing a person on the locomotive about the vehicle if the vehicle is located on the railroad  
15 crossing.

15. The method of Claim 11, wherein the first object is a control box, the second object is a vehicle and said step of transmitting further includes  
20 transmitting the impulse radio signal at the vehicle when the control box learns of the presence of a locomotive.

16. The method of Claim 11, wherein said first  
25 object is a control box, the second object is a railroad pole and said step of transmitting further includes transmitting the impulse radio signal at the railroad pole when the control box learns of the presence of a locomotive.

30



17. The method of Claim 16, further comprising the steps of:

scanning the railroad crossing to determine whether a vehicle is located on the railroad crossing;  
5 and

informing a person on the locomotive about the vehicle if the vehicle is located on the railroad crossing.

10

18. The method of Claim 11, wherein said first  
15 object is a locomotive, the second object is a work vehicle and said step of receiving further includes receiving the impulse radio signal at the work vehicle when the locomotive is in the vicinity of the work vehicle.

20

19. The method of Claim 11, wherein said first  
object is a first locomotive, the second object is a second locomotive and said step of receiving further includes receiving the impulse radio signal towards  
25 the second locomotive when the first locomotive is in the vicinity of the second locomotive.

20. The method of Claim 11, further comprising the step of determining a distance between a  
30 locomotive carrying the transmitting impulse radio unit and said receiving impulse radio unit.

21. An apparatus comprising:

a transmitting impulse radio unit capable of transmitting an impulse radio signal to a receiving  
5 impulse radio unit that is coupled to an object when there is a potentially dangerous situation on a railroad, wherein said object is capable of alerting a person about the potentially dangerous situation.

10 22. The apparatus of Claim 21, wherein said apparatus is a locomotive or a control box.

15 23. The apparatus of Claim 21, wherein said object is a vehicle and said transmitting impulse radio unit transmits the impulse radio signal at the vehicle when the locomotive is in the vicinity of a  
20 railroad crossing.

24. The apparatus of Claim 21, wherein said object is a railroad pole and said transmitting impulse radio unit transmits the impulse radio signal  
25 towards the railroad pole when the locomotive is in the vicinity of a railroad crossing.

25. The apparatus of Claim 21, wherein said object is a work vehicle and said receiving impulse  
30 radio unit receives the impulse radio signal towards

the work vehicle when the locomotive is a predetermined distance from the work vehicle.

26. The apparatus of Claim 21, wherein said  
5 object is a second locomotive and said receiving impulse radio unit receives the impulse radio signal at the second locomotive when the first locomotive is in the vicinity of the second locomotive.

10 27. A method for preventing train accidents, said method comprising the steps of:

transmitting an impulse radio signal to a receiving impulse radio unit that is coupled to an object when there is a potentially dangerous situation  
15 on a railroad; and

alerting a person about the potentially dangerous situation.

28. The method Claim 27, wherein a locomotive or  
20 a control box includes a transmitting impulse radio unit that transmits the impulse radio signal.

29. The method of Claim 27, wherein said object  
25 is a vehicle and said transmitting impulse radio unit transmits the impulse radio signal towards the vehicle when the locomotive is in the vicinity of a railroad crossing.

30. The method of Claim 27, wherein said object  
30 is a railroad pole and said transmitting impulse radio unit transmits the impulse radio signal towards the

railroad pole when the locomotive is in the vicinity of a railroad crossing.

31. The method of Claim 27, wherein said object  
5 is a work vehicle and said receiving impulse radio unit receives the impulse radio signal at the work vehicle when the locomotive is in the vicinity of the work vehicle.

10 32. The method of Claim 27, wherein said object is a second locomotive and said receiving impulse radio unit receives the impulse radio signal towards the second locomotive when the first locomotive is in the vicinity of the second locomotive.

15

33. An apparatus comprising:

a receiving impulse radio unit coupled to an object and capable of receiving an impulse radio signal from a transmitting impulse radio unit when  
20 there is a potentially dangerous situation on a railroad, wherein said object is capable of alerting a person about the potentially dangerous situation.

34. The apparatus of Claim 33, wherein said  
25 object is a locomotive or a control box.

35. The apparatus of Claim 33, wherein said apparatus is a vehicle, railroad pole, work vehicle or a second locomotive.

30

36. The apparatus of Claim 33, wherein said object is the vehicle and said transmitting impulse radio unit transmits the impulse radio signal towards the vehicle when the locomotive is a predetermined  
5 distance from a railroad crossing.

37. The apparatus of Claim 33, wherein said object is the railroad pole and said transmitting impulse radio unit transmits the impulse radio signal  
10 towards the railroad pole when the locomotive is a predetermined distance from a railroad crossing.

38. The apparatus of Claim 37, wherein said receiving impulse radio unit scans the railroad  
15 crossing to determine whether the vehicle is located on the railroad crossing and if yes then a person on the locomotive is informed about the vehicle.

39. The apparatus of Claim 33, wherein said  
20 object is the work vehicle and said receiving impulse radio unit receives the impulse radio signal at the work vehicle when the locomotive is in the vicinity of the work vehicle.

25

40. The apparatus of Claim 33, wherein said object is the second locomotive and said receiving impulse radio unit receives the impulse radio signal  
30 at the second locomotive when the first locomotive is in the vicinity of the second locomotive.

41. The apparatus of Claim 33, wherein said receiving impulse radio unit is capable of determining a distance between a locomotive carrying the transmitting impulse radio unit and said receiving impulse radio unit.

42. A method for preventing train accidents, said method comprising the steps of:

10 receiving at an object an impulse radio signal from a transmitting impulse radio unit when there is a potentially dangerous situation on a railroad; and alerting a person about the potentially dangerous situation.

15

43. The method of Claim 42, wherein a vehicle or a railroad pole includes a receiving impulse radio unit that receives the impulse radio signal.

20

44. The method of Claim 42, wherein said object is a locomotive and said transmitting impulse radio unit transmits the impulse radio signal towards the vehicle when the locomotive is in the vicinity of a railroad crossing.

25

45. The method of Claim 42, wherein said object is a control box and said transmitting impulse radio unit transmits the impulse radio signal towards the railroad pole when a locomotive is in the vicinity of a railroad crossing.

30

46. The method of Claim 45, further comprising the steps of:

scanning the railroad crossing to determine whether the vehicle is located on the railroad crossing; and  
5

informing a person on the locomotive about the vehicle if the vehicle is located on the railroad crossing.

10 47. The method of Claim 42, wherein said object is a locomotive and said receiving impulse radio unit receives the impulse radio signal at a work vehicle when the locomotive is in the vicinity of the work vehicle.

15 48. The method of Claim 42, wherein said object is the locomotive and said receiving impulse radio unit receives the impulse radio signal at a second locomotive when the first locomotive is in the vicinity of the second locomotive.  
20

49. A subway collision avoidance system comprising:

a transmitting impulse radio unit, coupled to a first subway train, capable of transmitting an impulse radio signal when there is a potentially dangerous situation on a track; and  
25

a receiving impulse radio unit, coupled to a second subway train, capable of receiving the impulse radio signal and further capable of alerting a person about the potentially dangerous situation.  
30

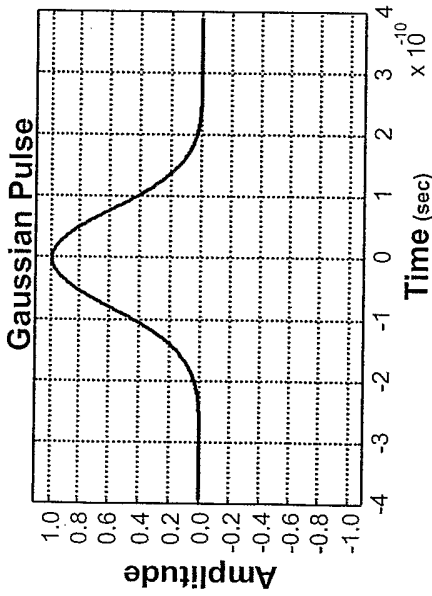

FIG. 1A

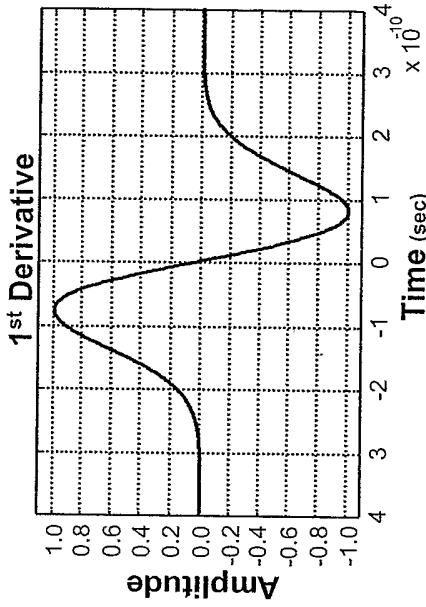

FIG. 1B

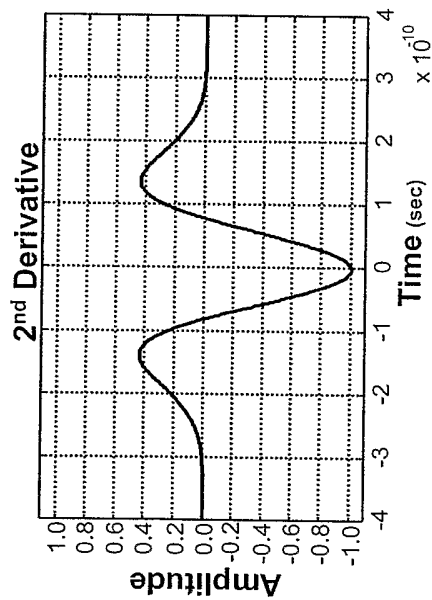

FIG. 1C

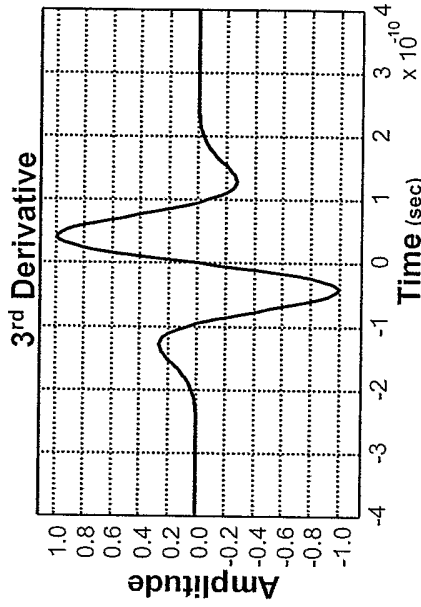

FIG. 1D



2/26

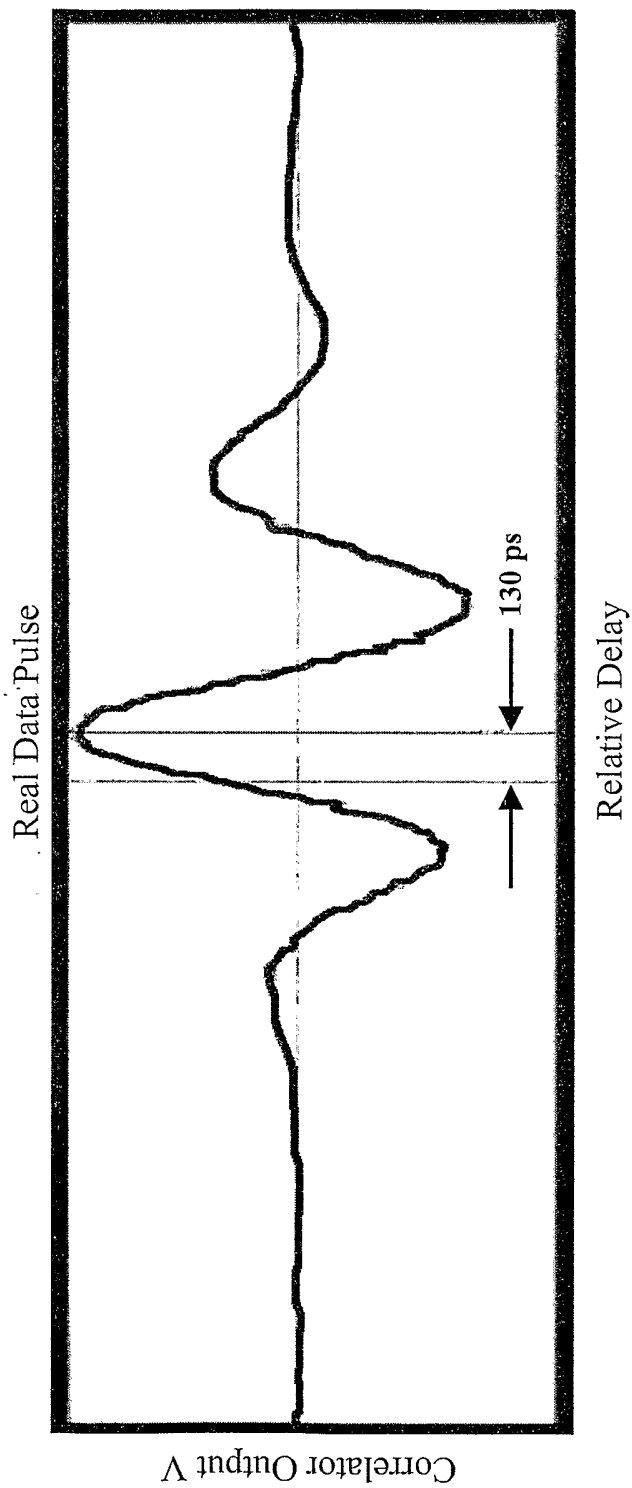

FIG. 1E

3/26

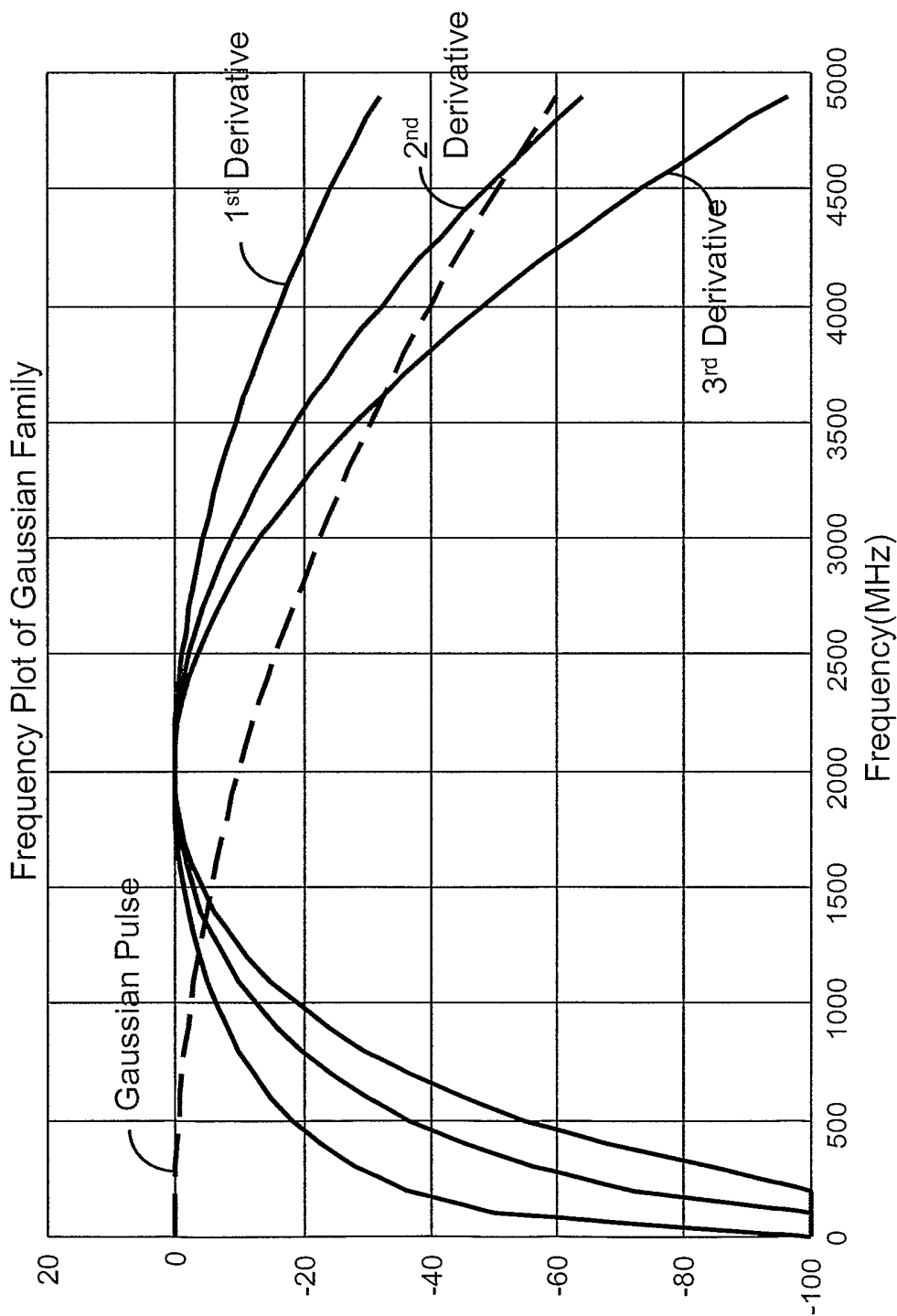

FIG. 1F

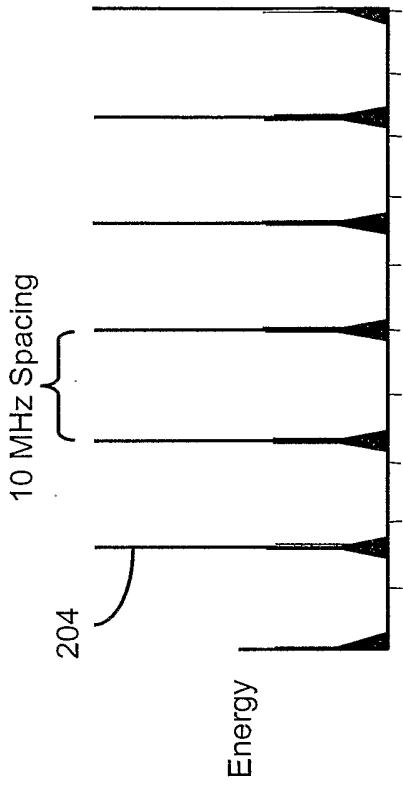

FIG. 2B

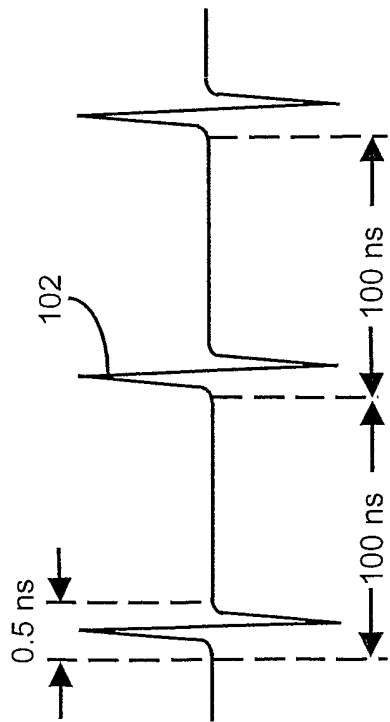

FIG. 2A

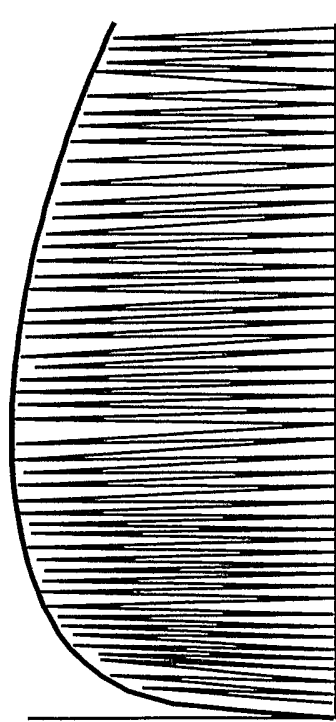

FIG. 2C

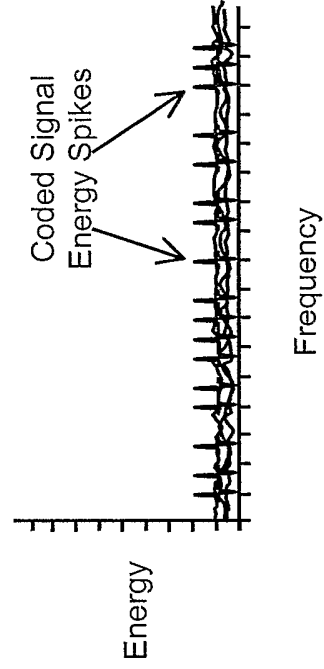

FIG. 2D

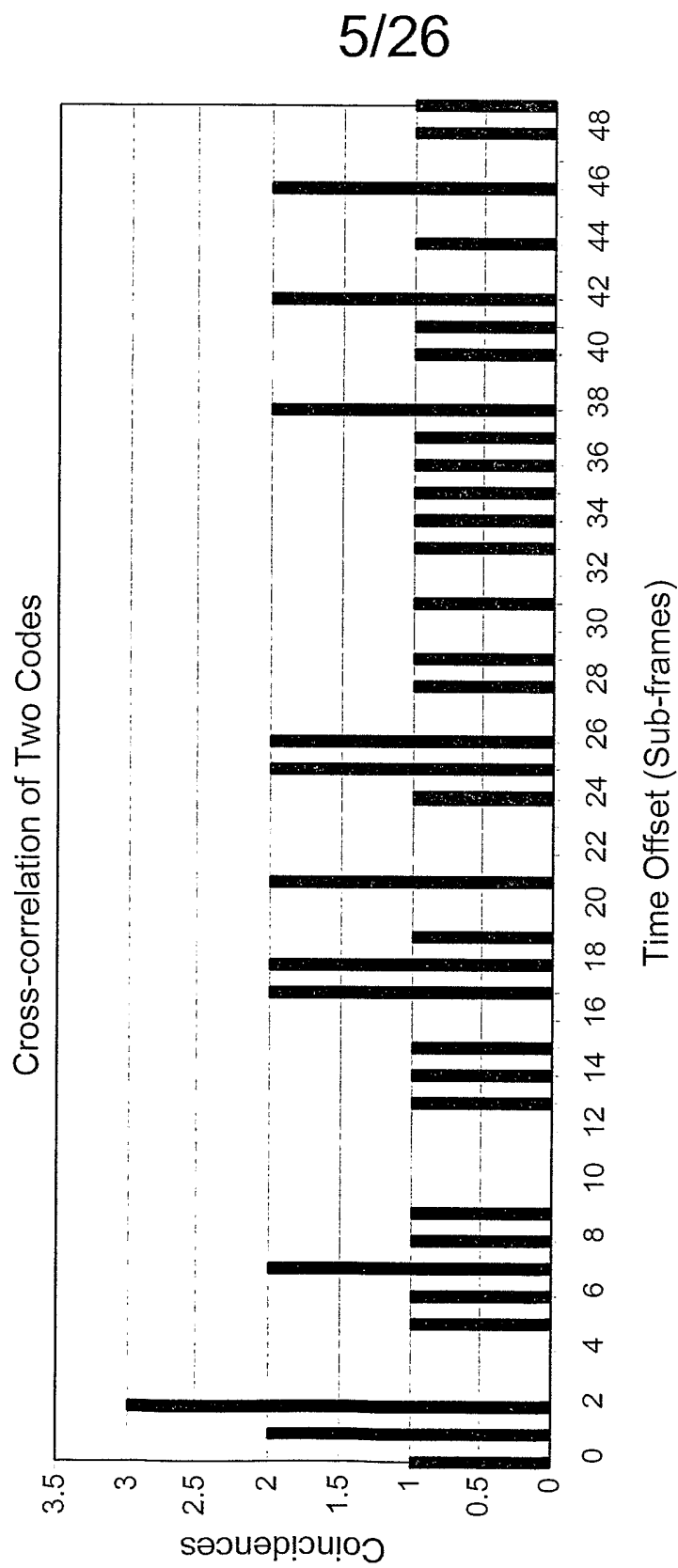

FIG. 3

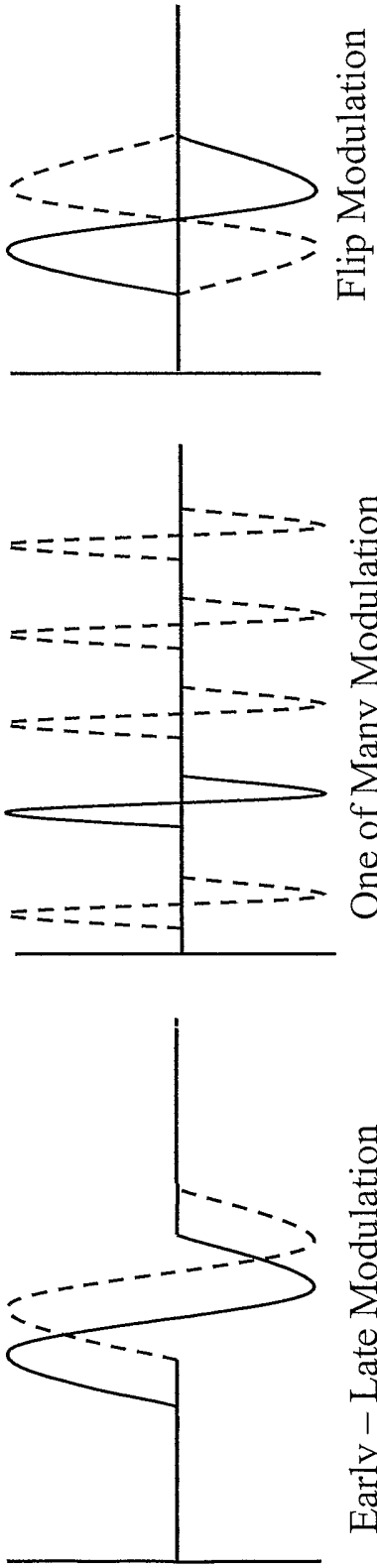

FIG. 4A

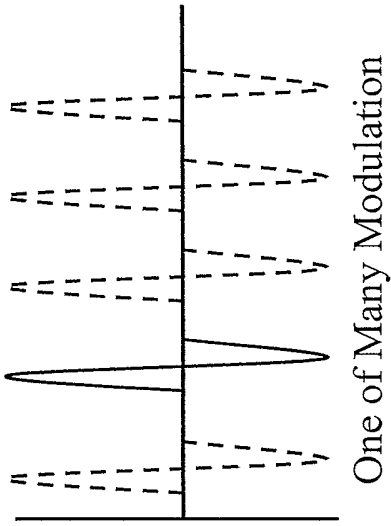

FIG. 4B

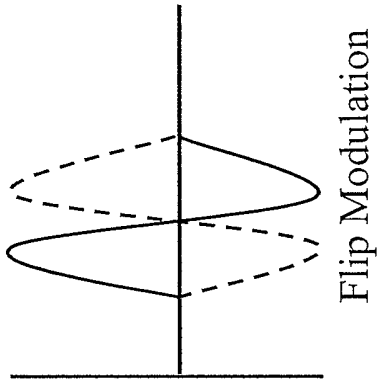

FIG. 4C

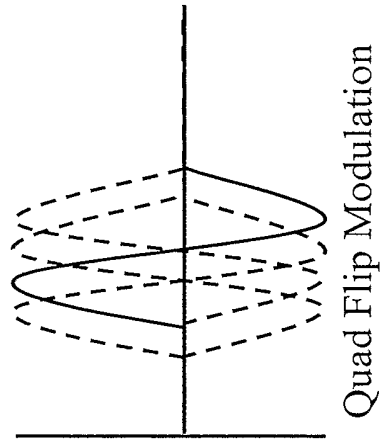

FIG. 4D

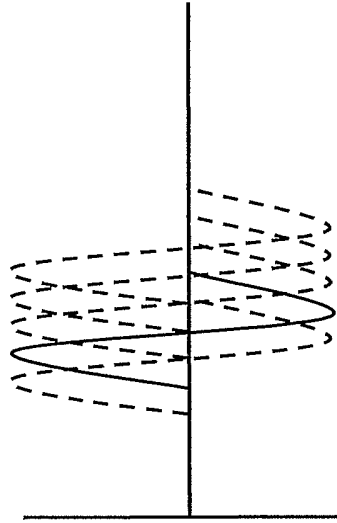

FIG. 4E

7/26

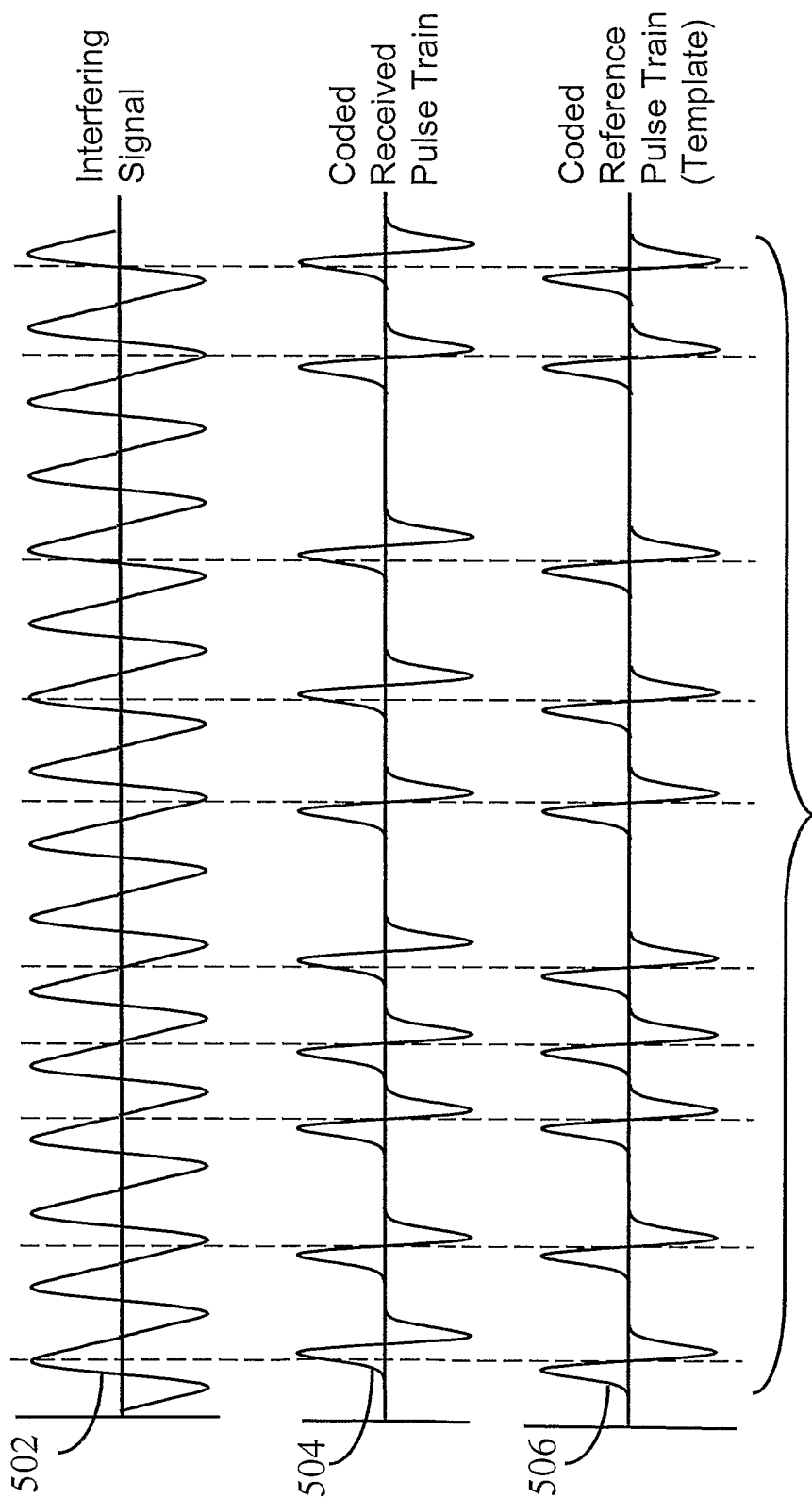

FIG. 5A

8/26

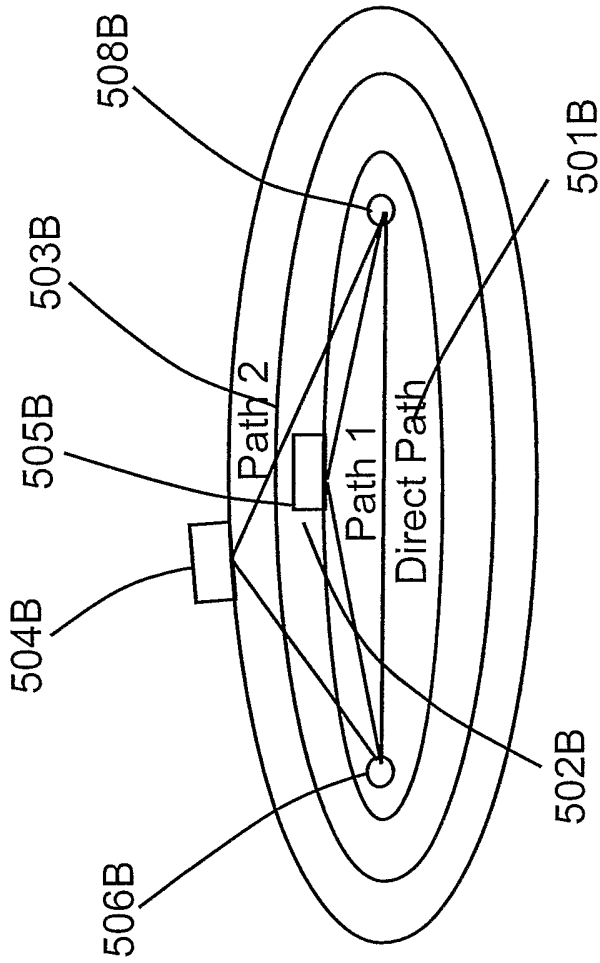

FIG. 5B

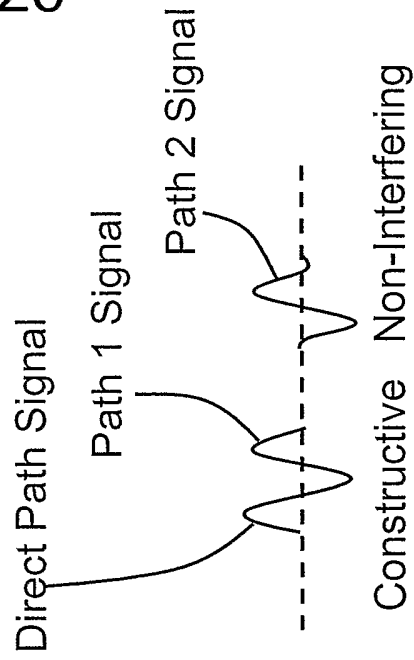
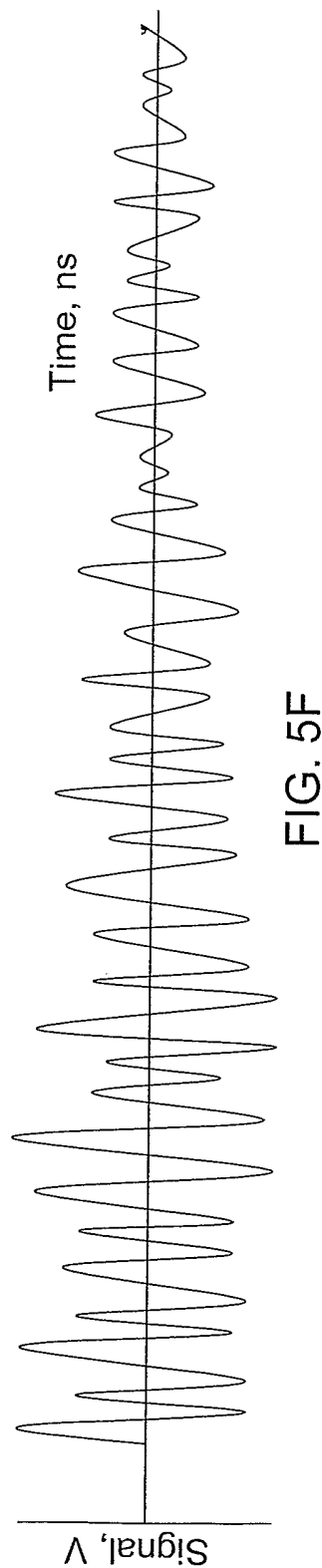
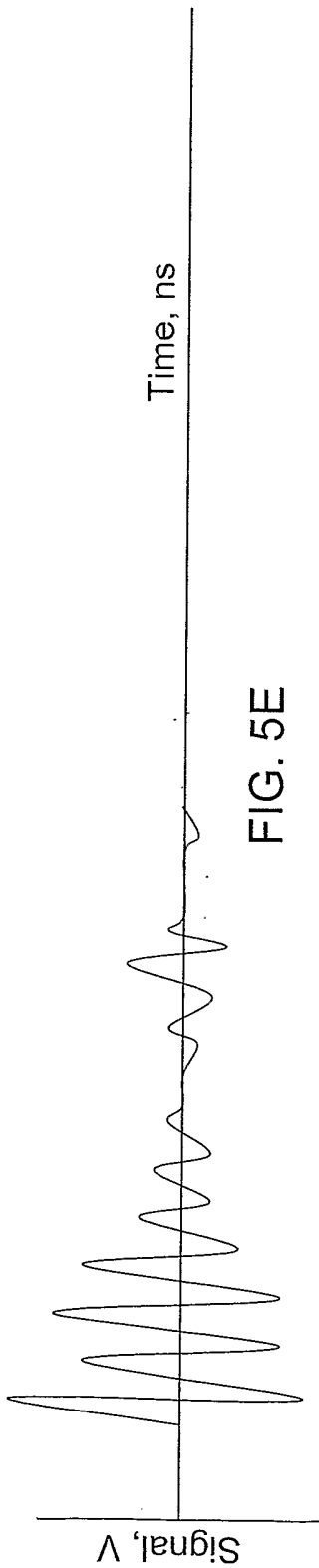
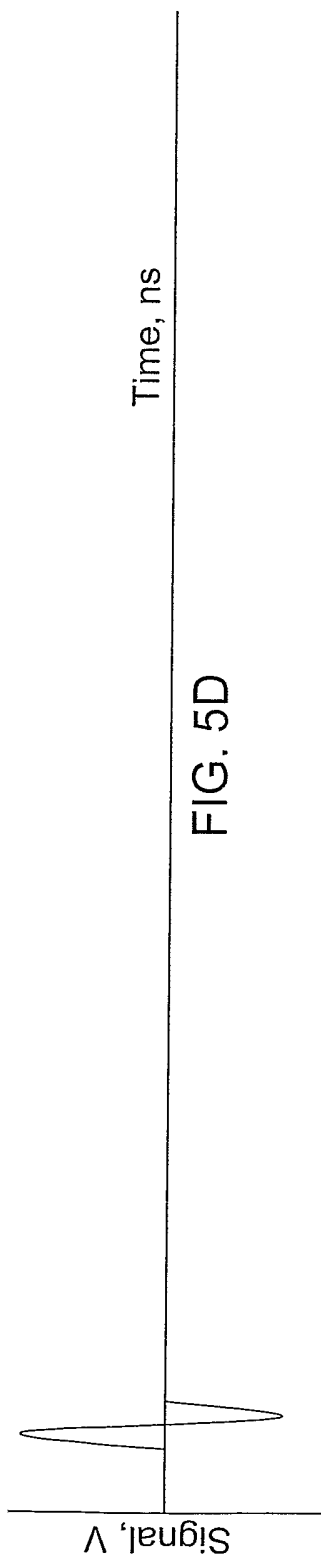

FIG. 5C

9/26





10/26

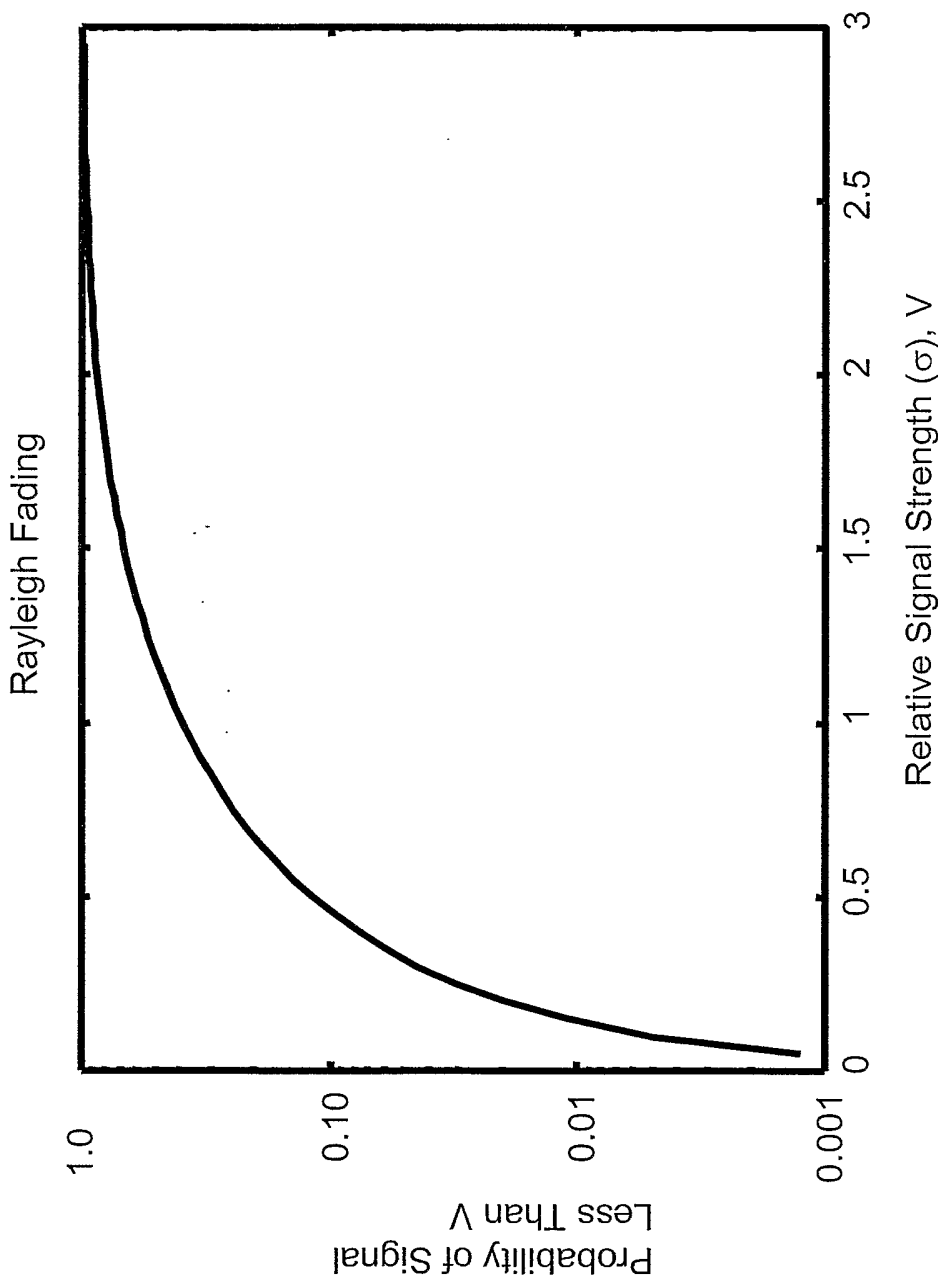
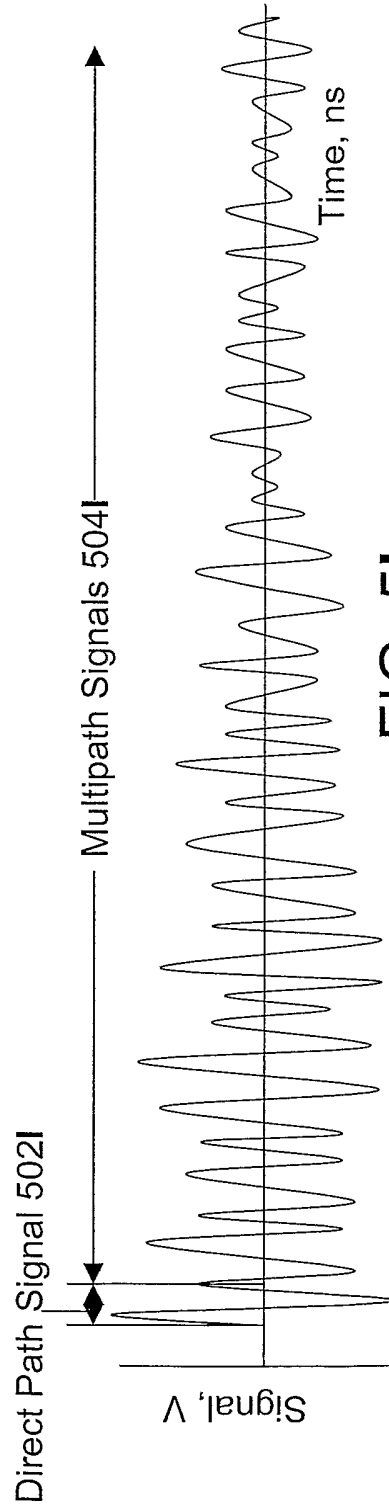
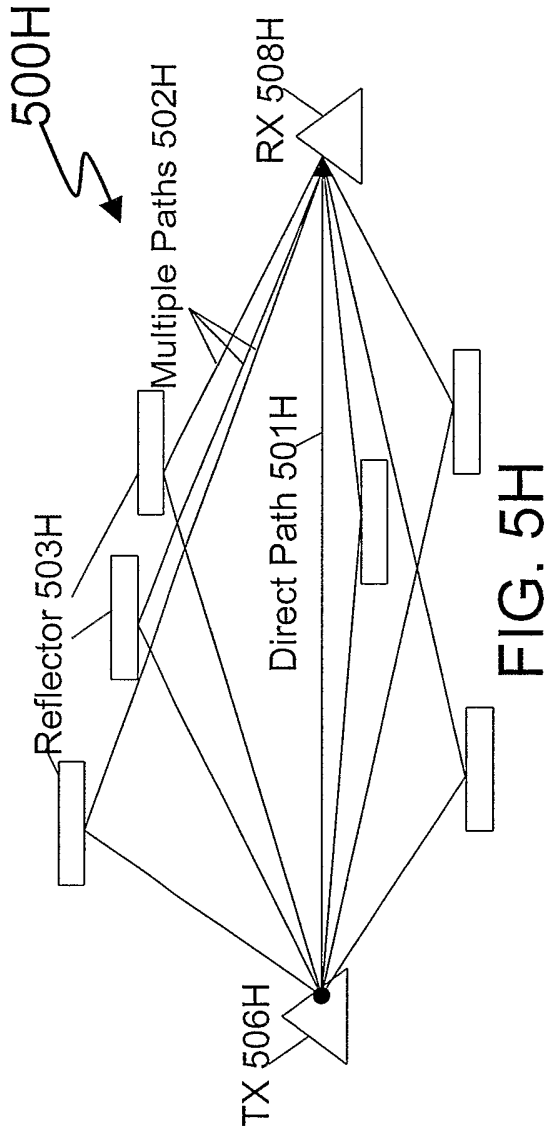

Fig. 5G

11/26



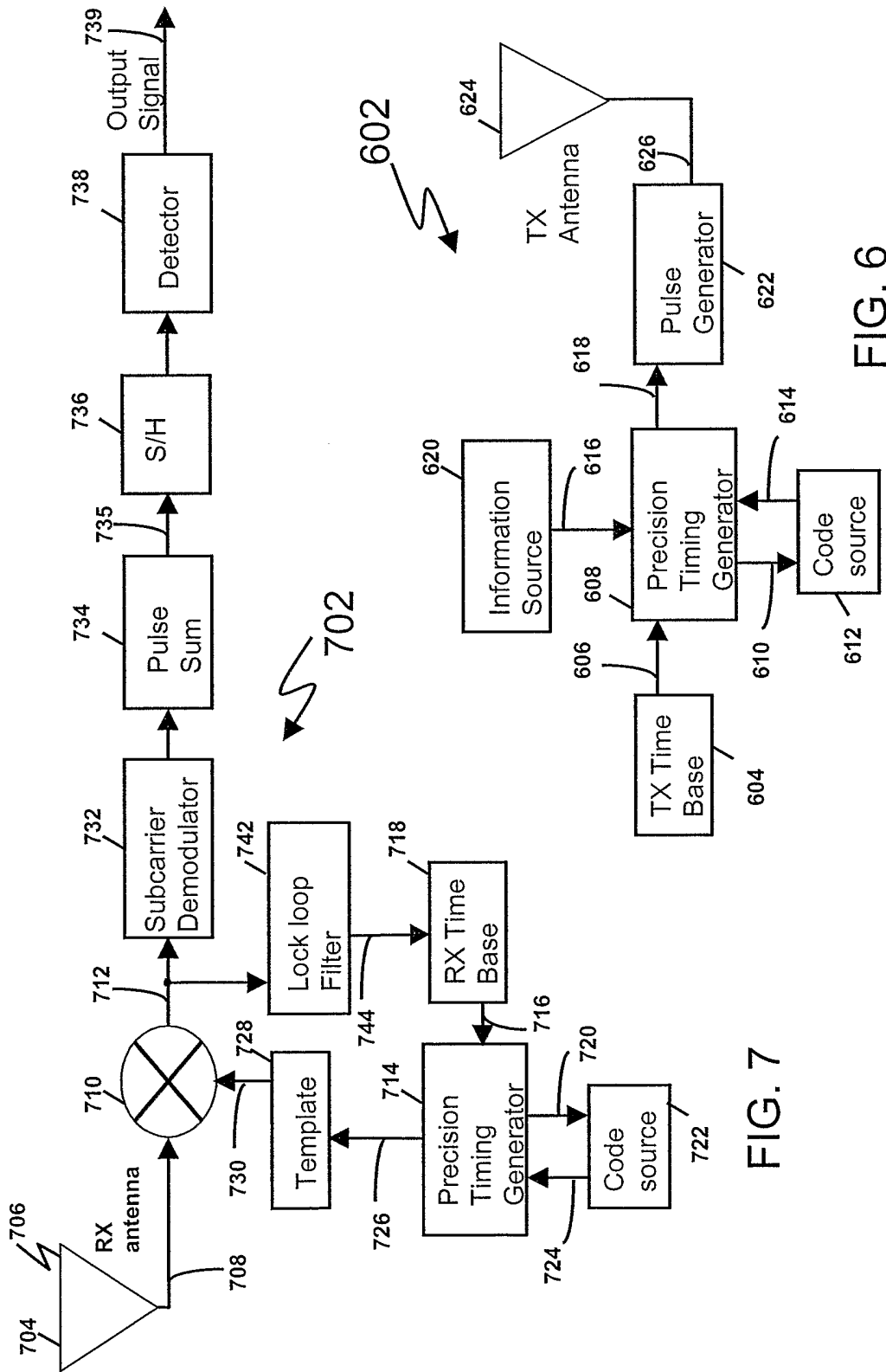

FIG. 6

FIG. 7

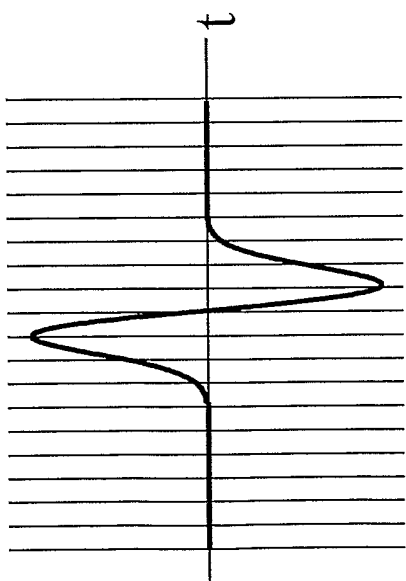

FIG. 8A

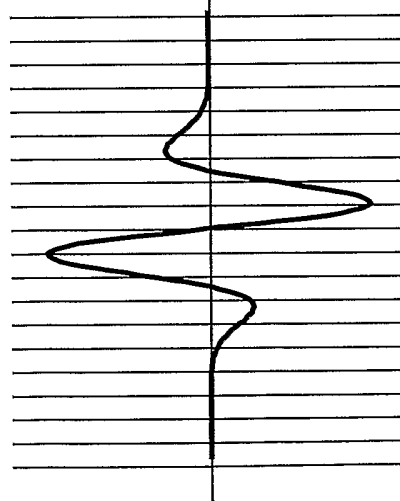

FIG. 8C

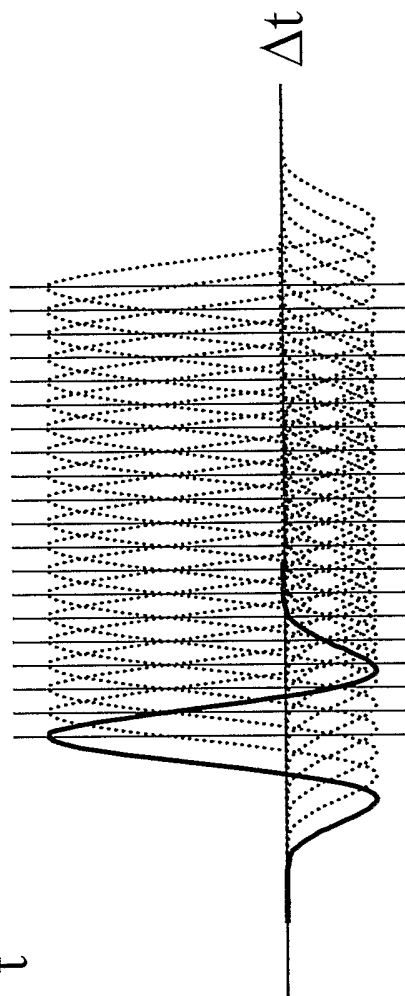

FIG. 8B

Corresponding to  
each  $\Delta t$

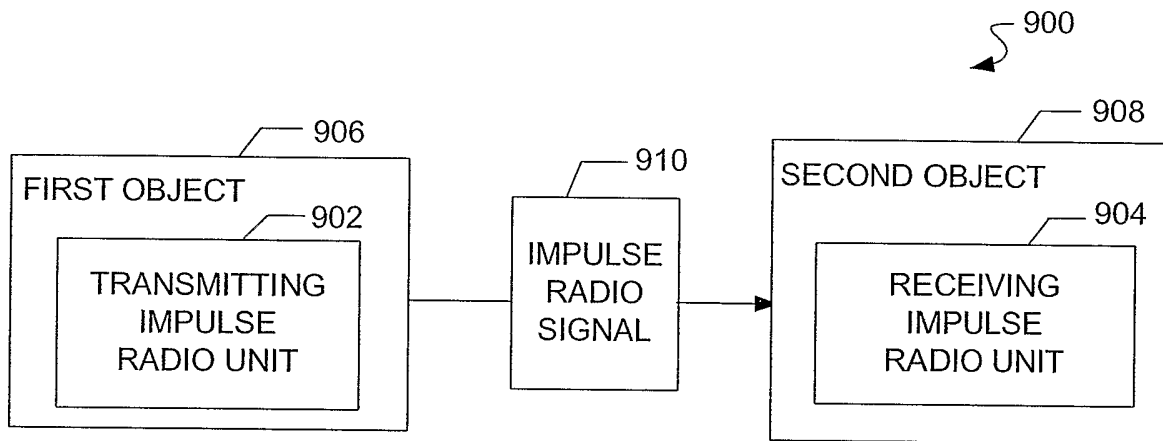

FIG. 9

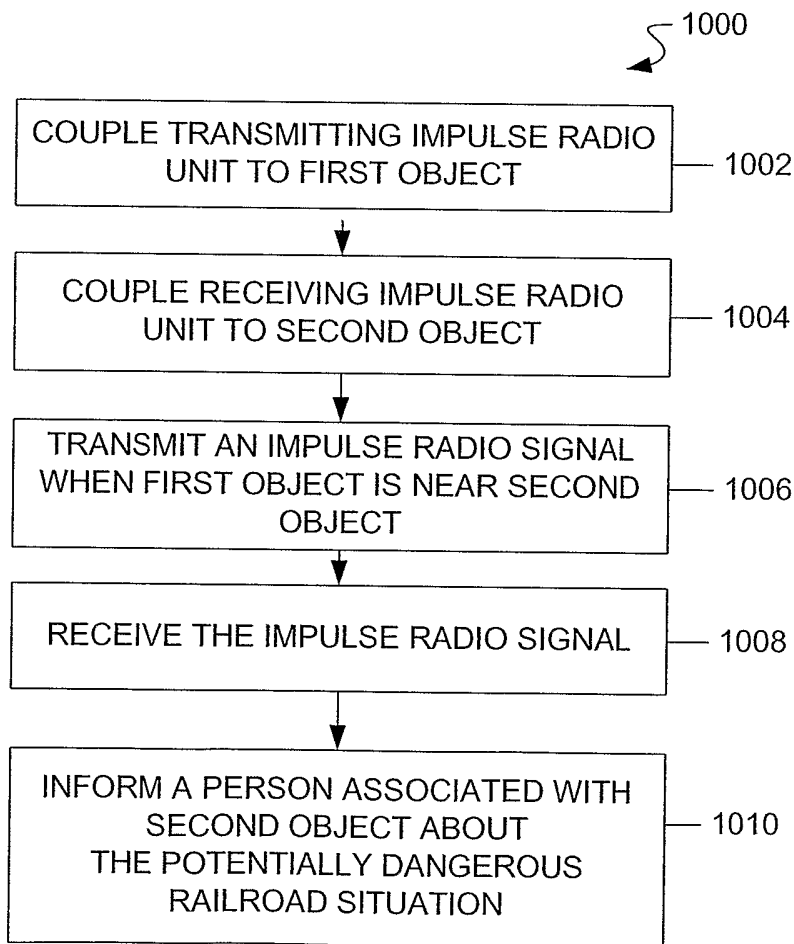

FIG. 10

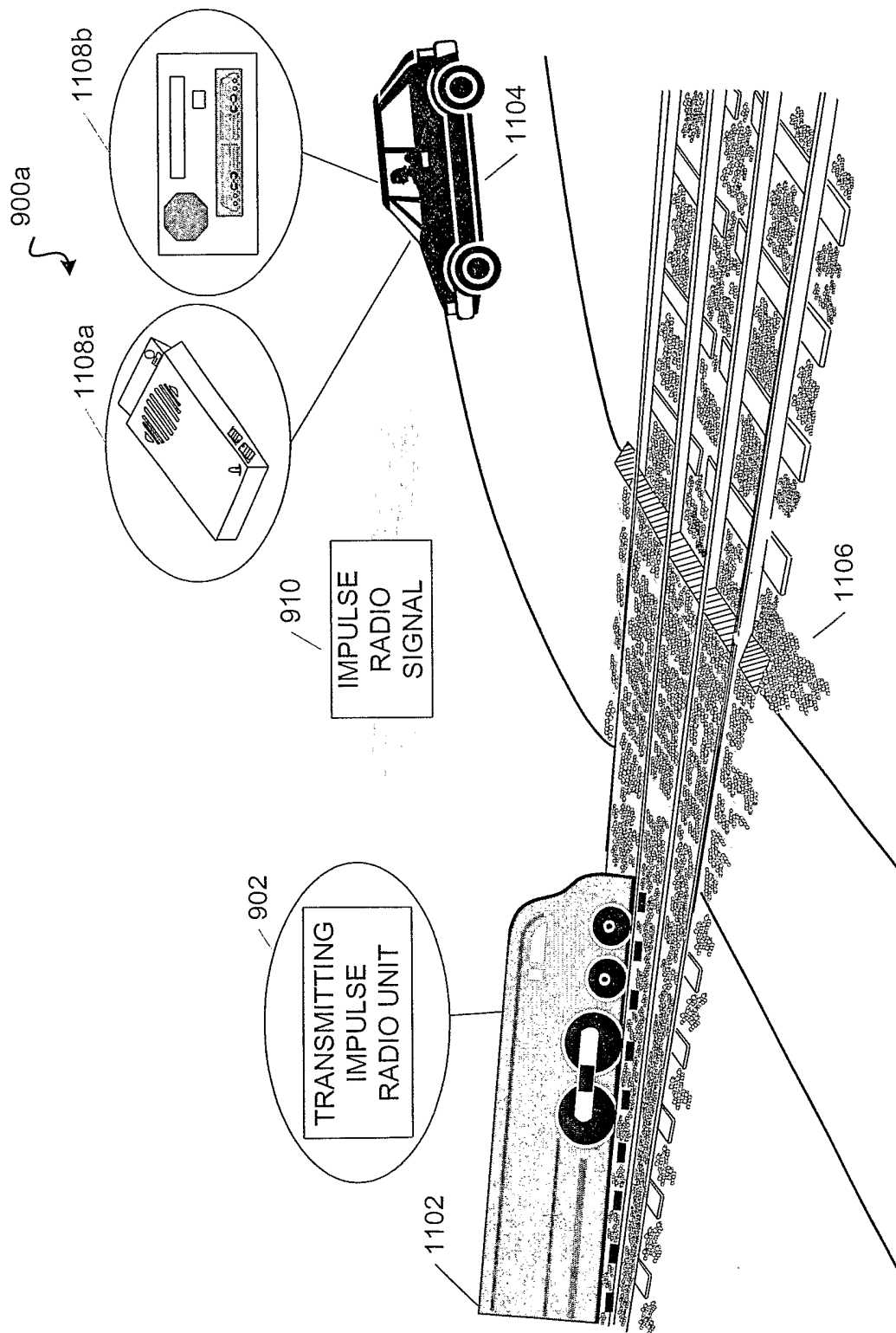

FIG. 11

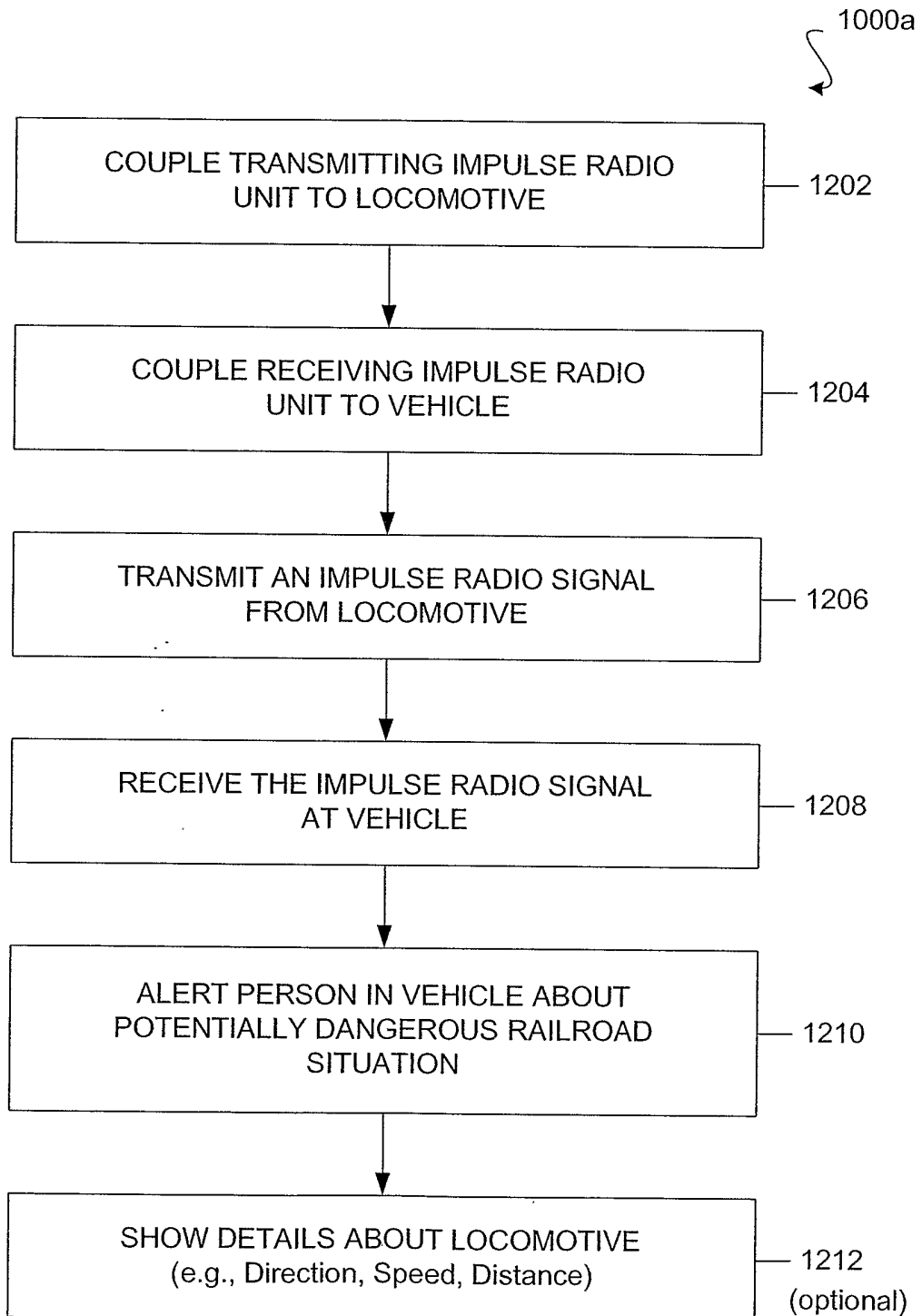

FIG. 12

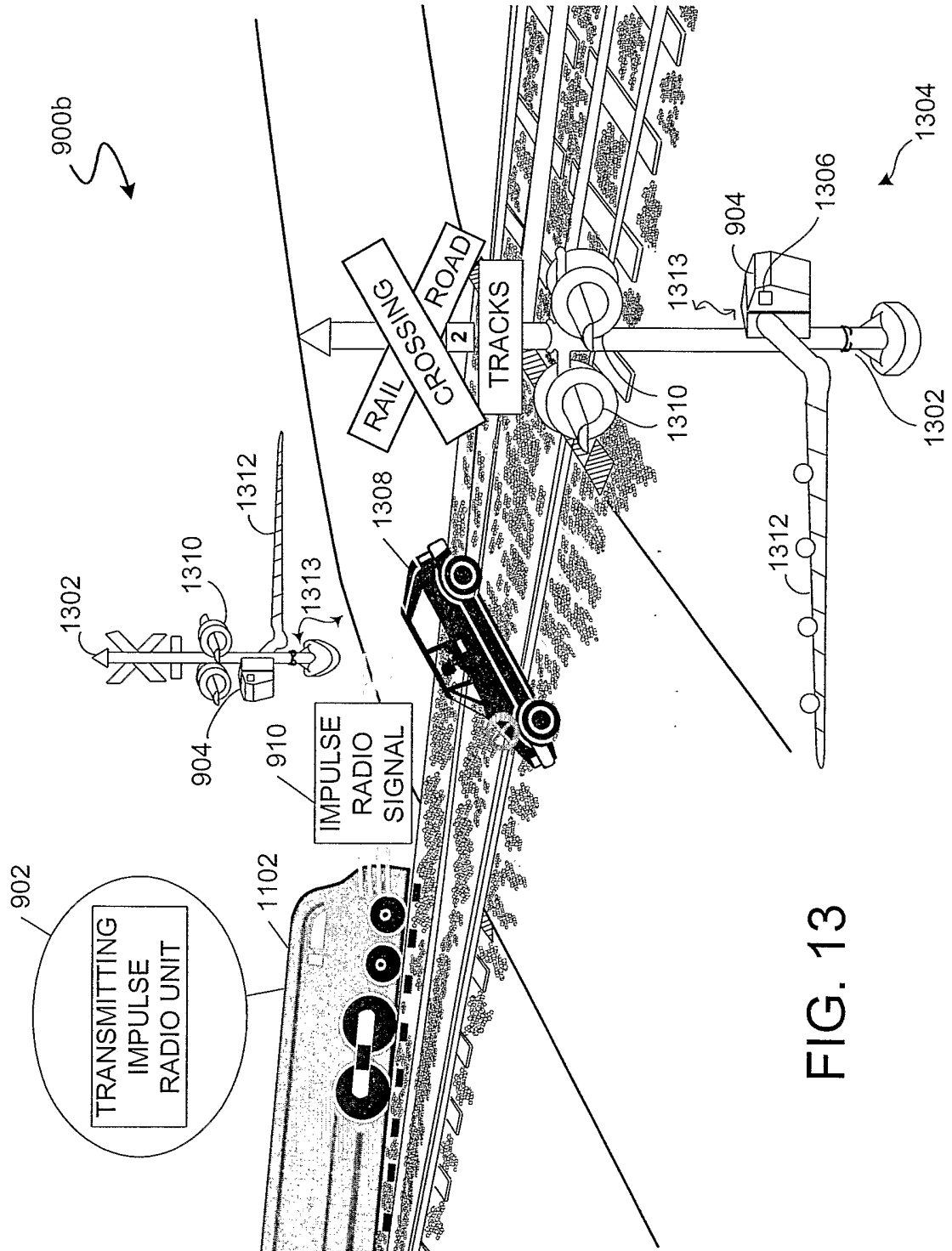

FIG. 13



18/26

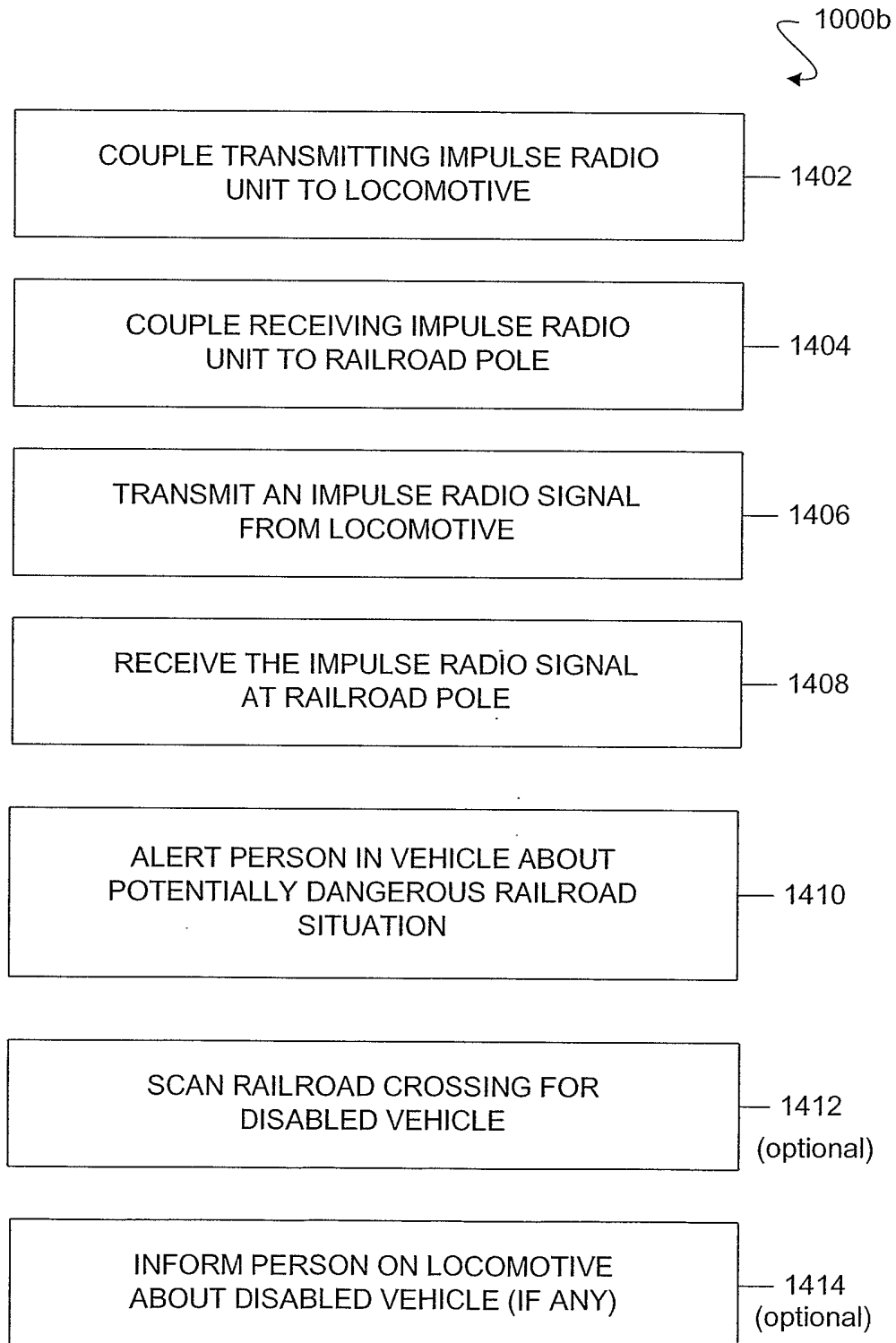

FIG. 14

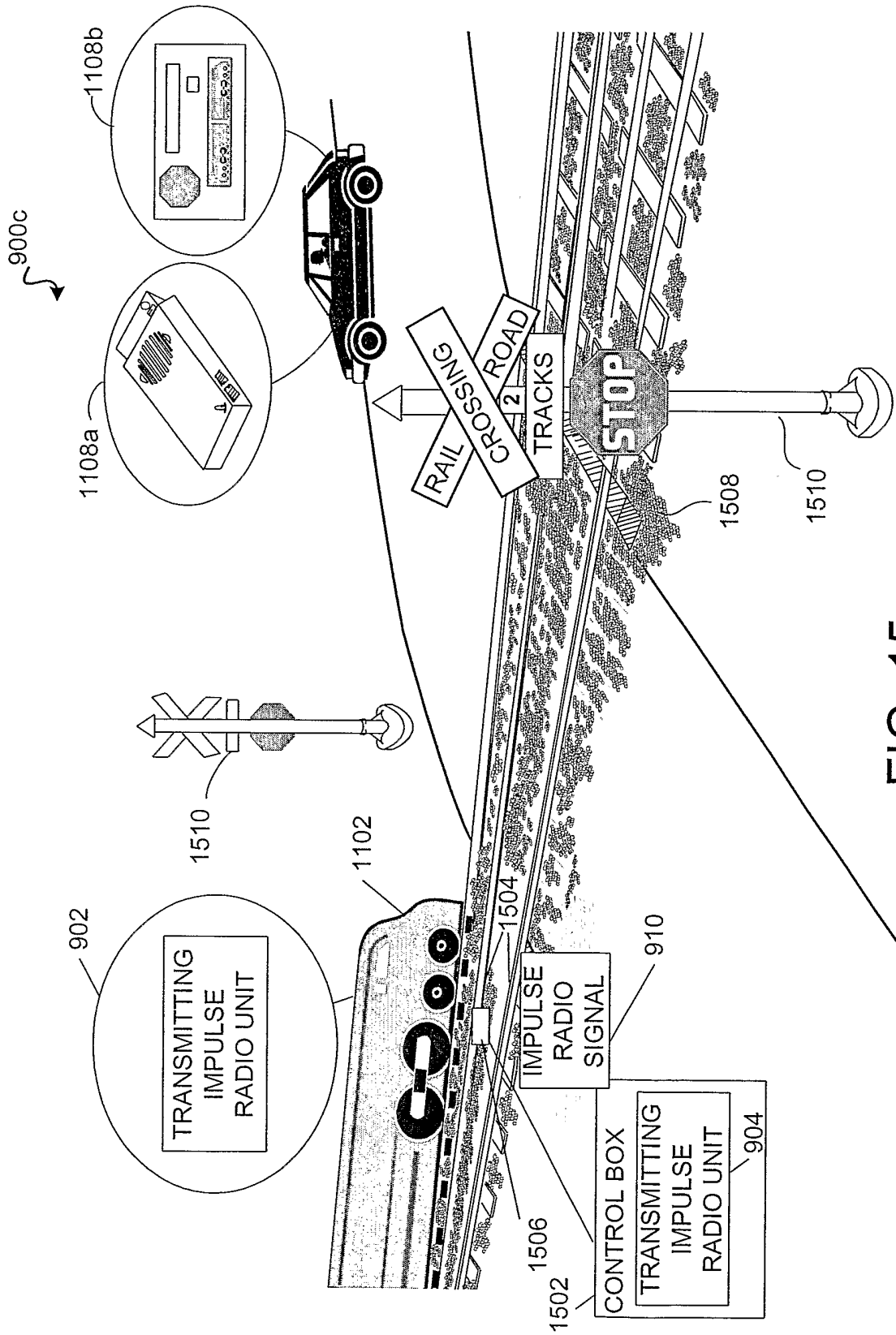

FIG. 15

20/26

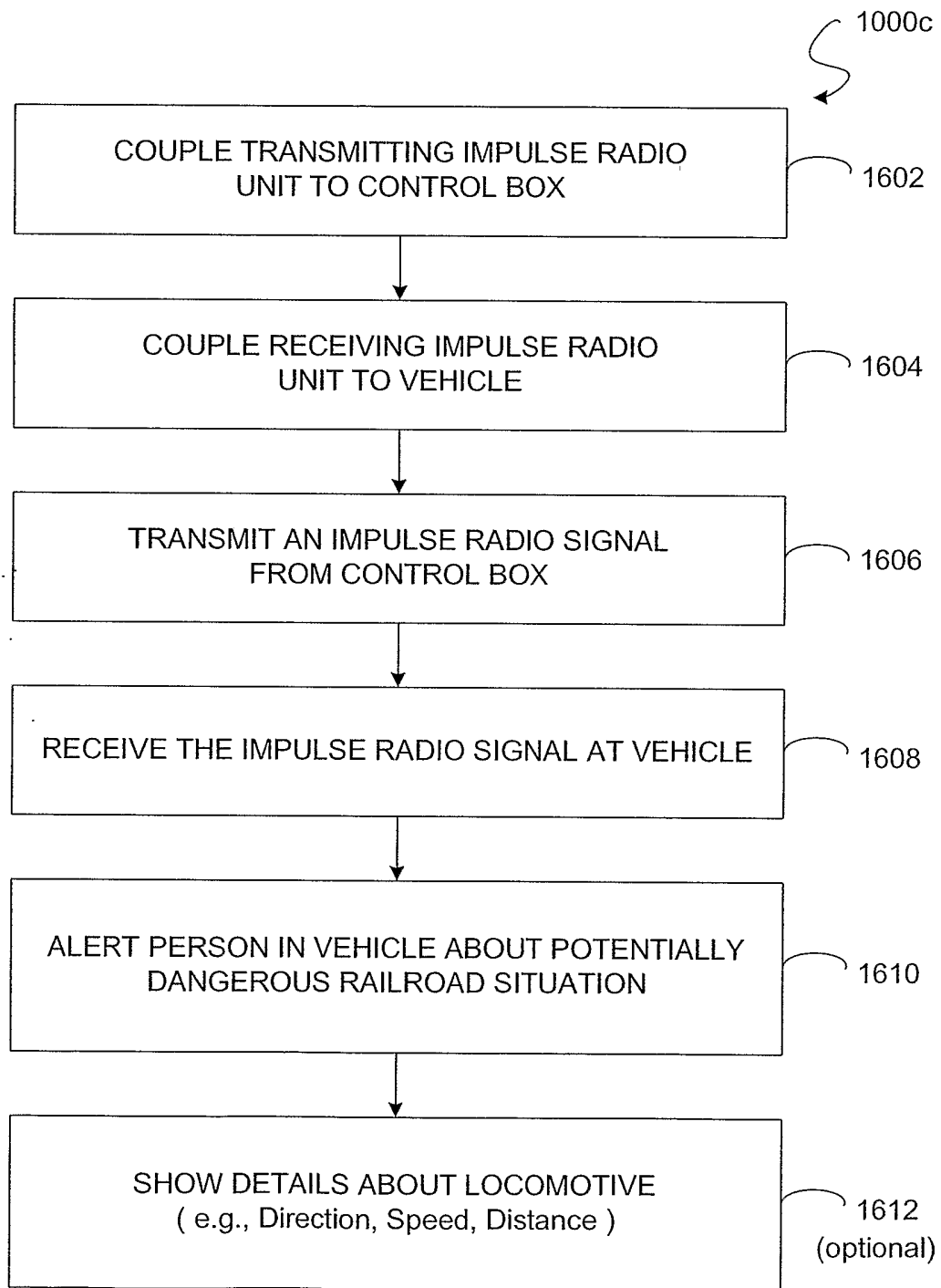

FIG. 16

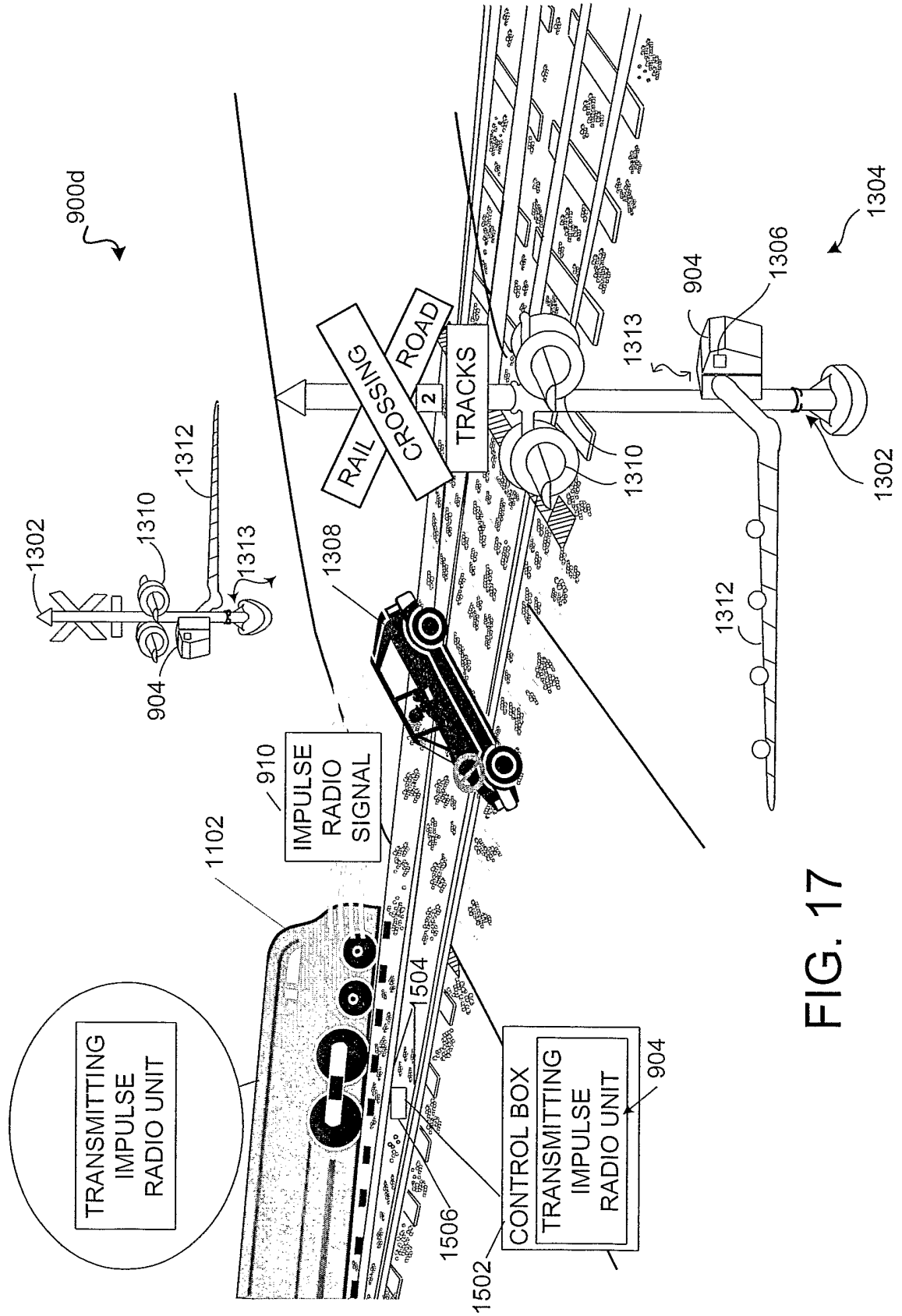

FIG. 17

22/26

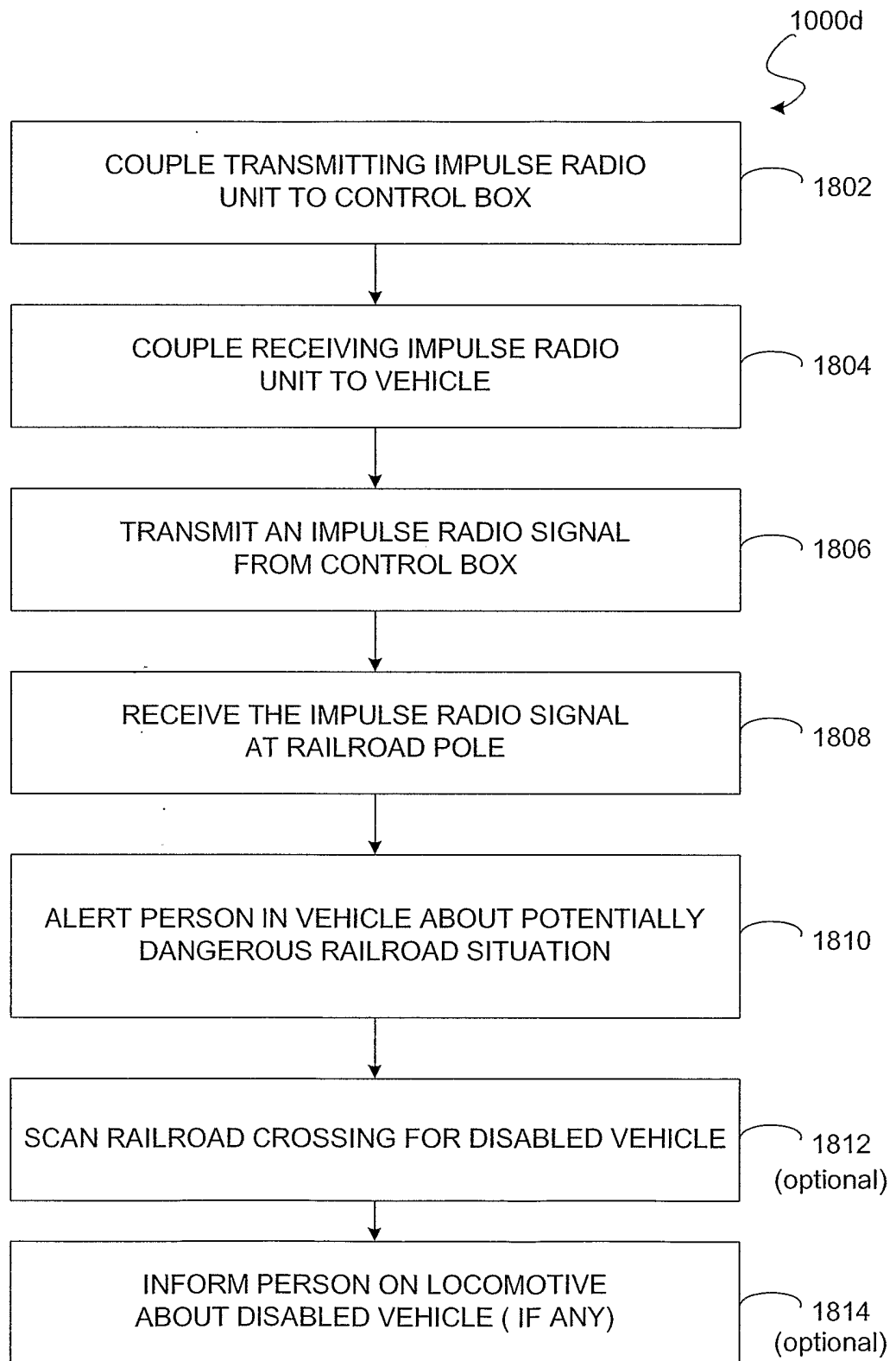

FIG. 18

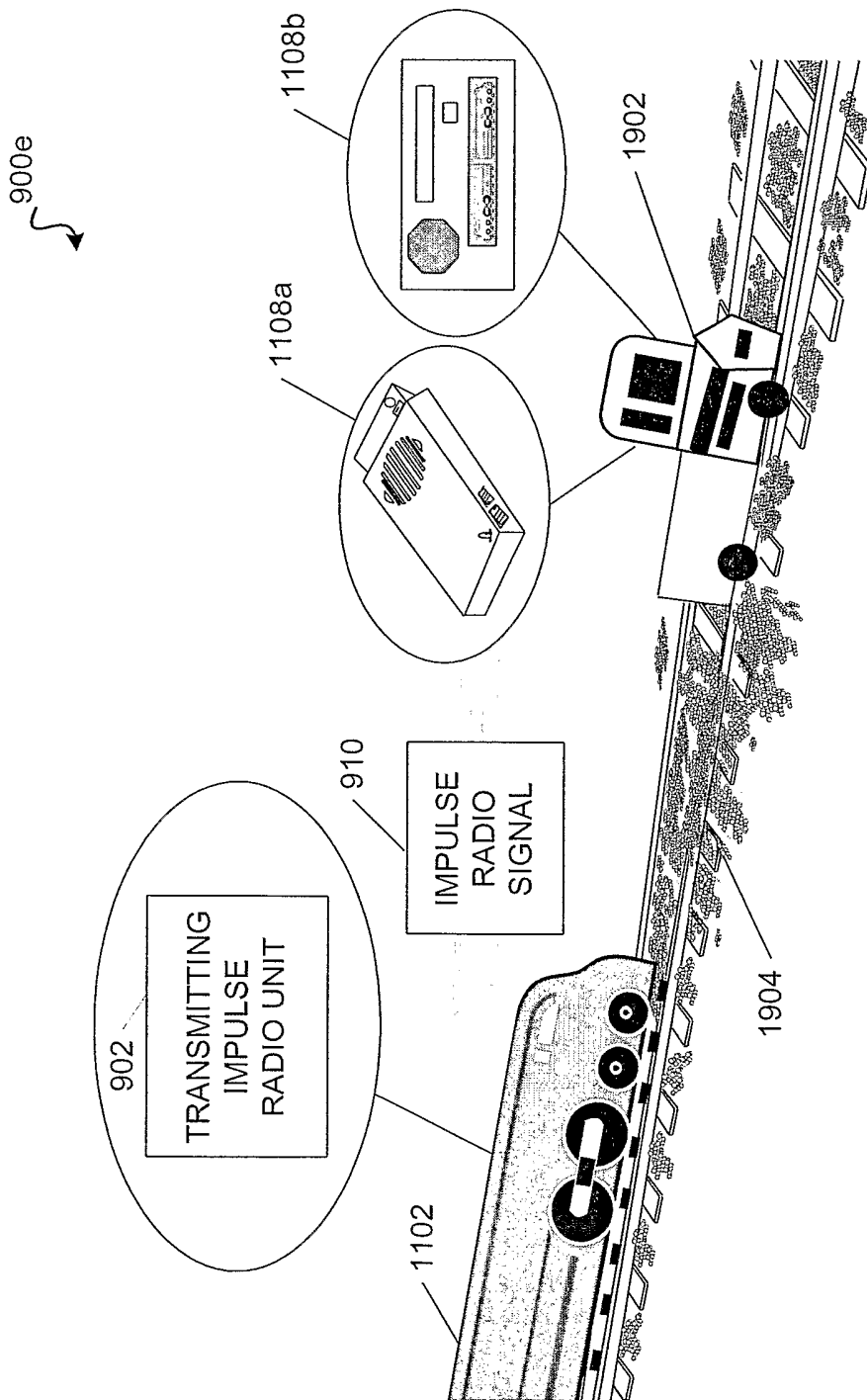

FIG. 19

24/26

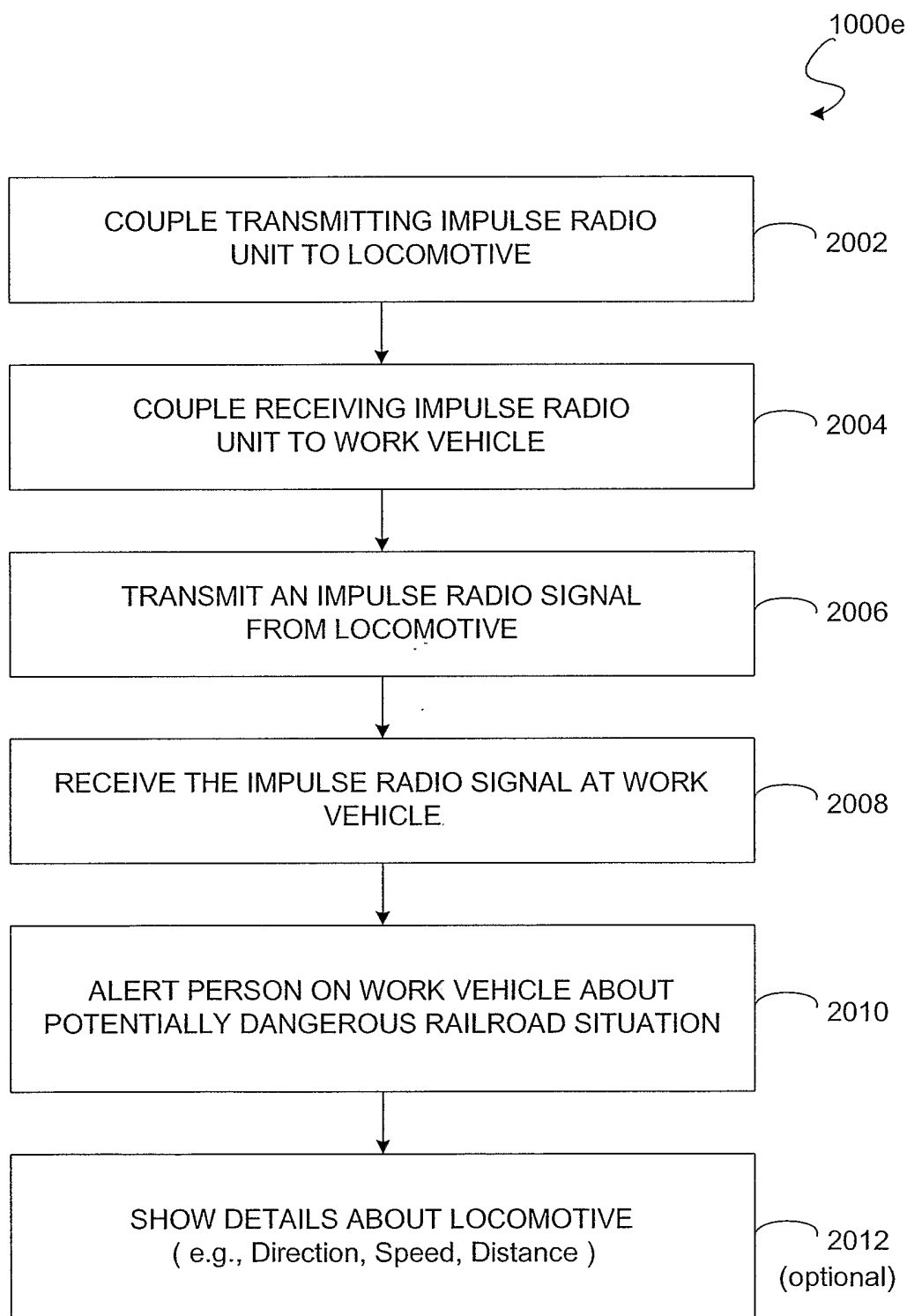

FIG. 20

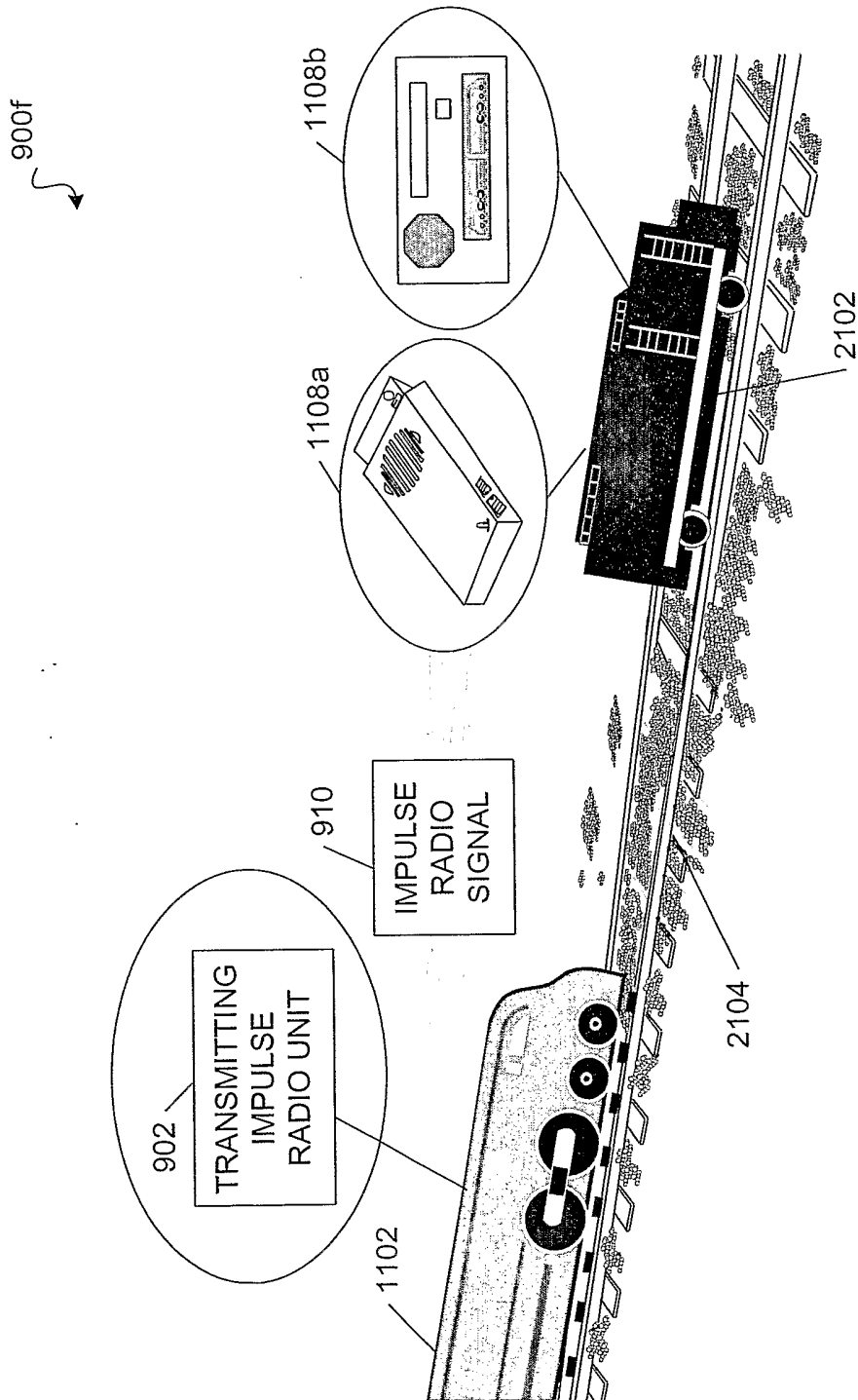

FIG. 21



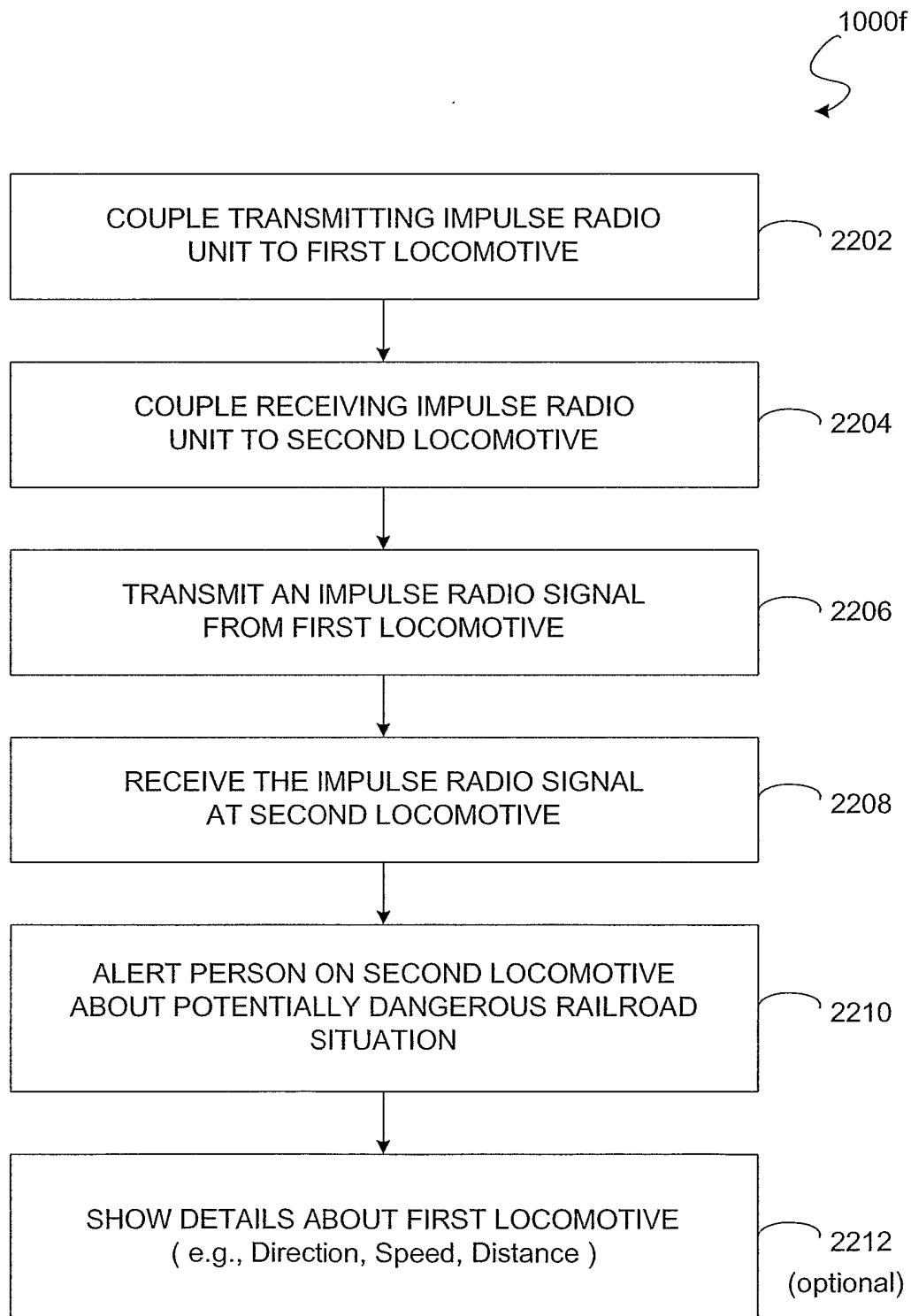

FIG. 22