

June 7, 1955

P. H. MAURER

2,710,186

DOOR OPERATION AND CONTROL

Original Filed July 21, 1948

4 Sheets-Sheet 1

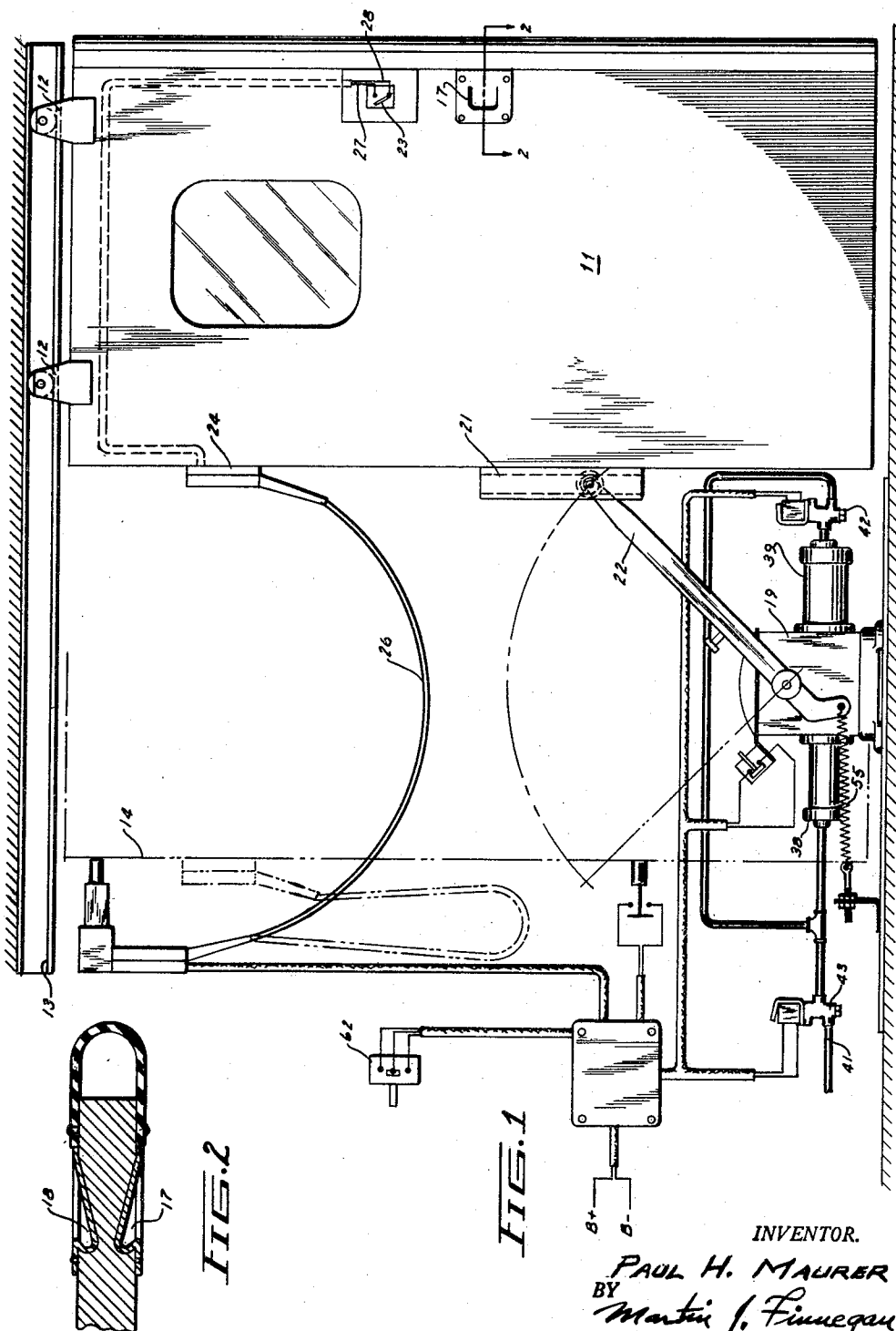

INVENTOR.

PAUL H. MAURER
BY *Martin J. Finnegan*
ATTORNEY

June 7, 1955

P. H. MAURER

2,710,186

DOOR OPERATION AND CONTROL

Original Filed July 21, 1948

4 Sheets-Sheet 2

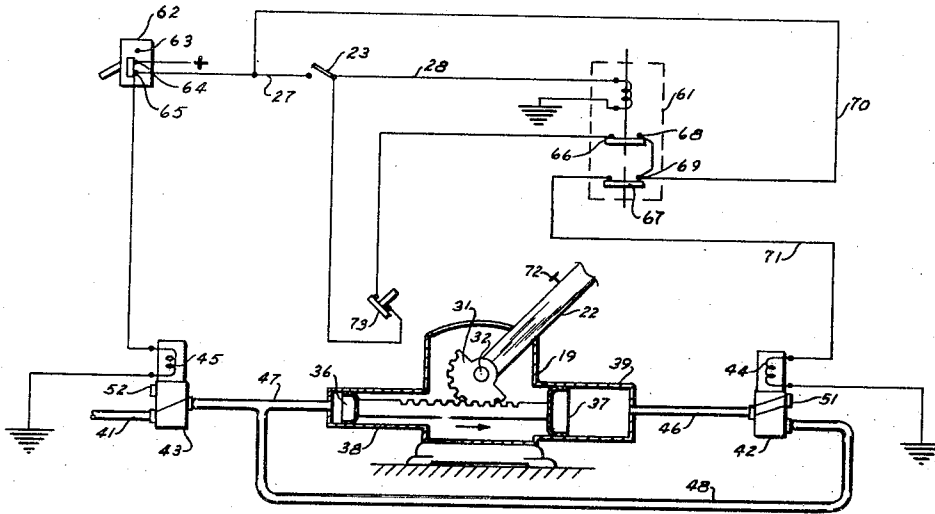

FIG. 3

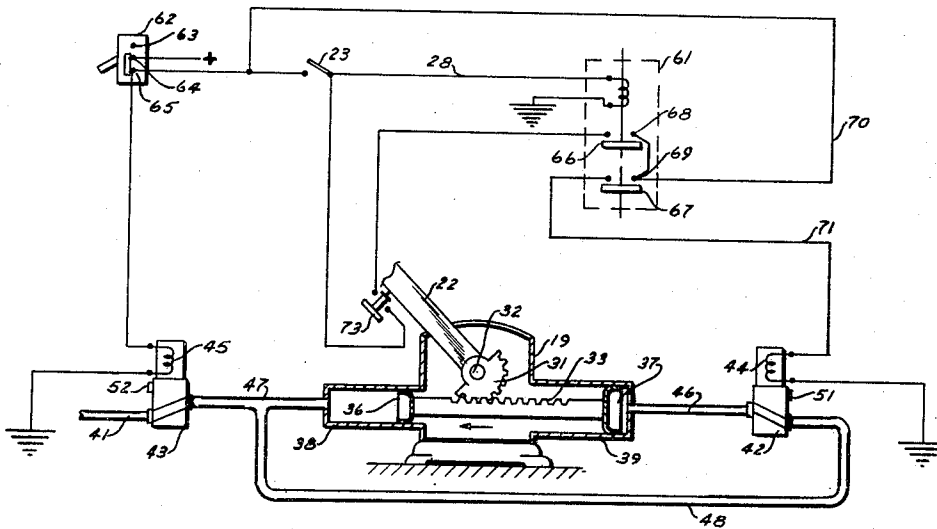

FIG. 4

INVENTOR.
PAUL H. MAURER
BY
Martin J. Finnegan
ATTORNEY

June 7, 1955

P. H. MAURER

2,710,186

DOOR OPERATION AND CONTROL

Original Filed July 21, 1948

4 Sheets-Sheet 3

FIG. 5

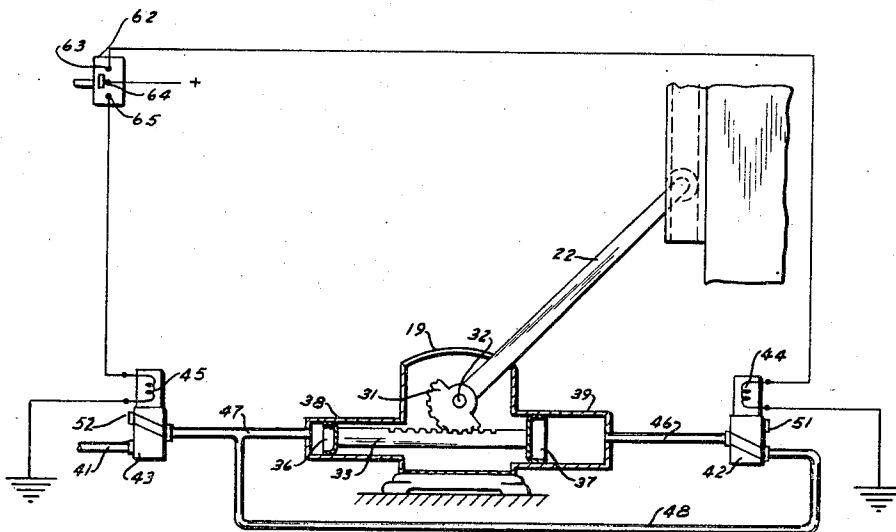
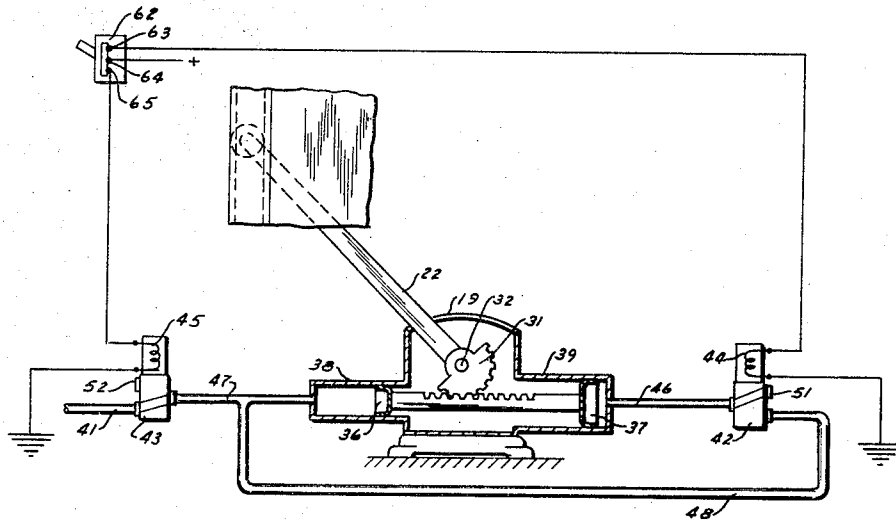

FIG. 6

INVENTOR.

PAUL H. MAURER
BY *Martin J. Finnegan*
ATTORNEY

June 7, 1955

P. H. MAURER

2,710,186

DOOR OPERATION AND CONTROL

Original Filed July 21, 1948

4 Sheets-Sheet 4

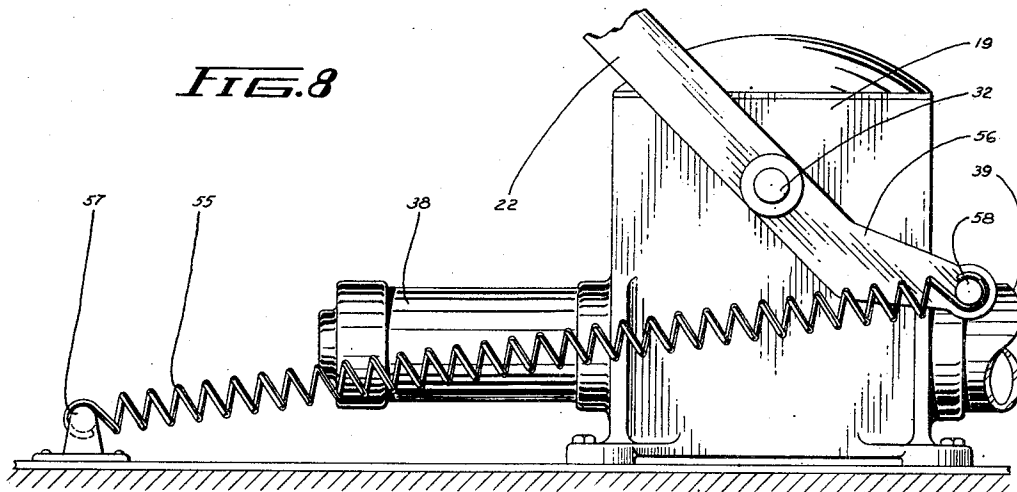
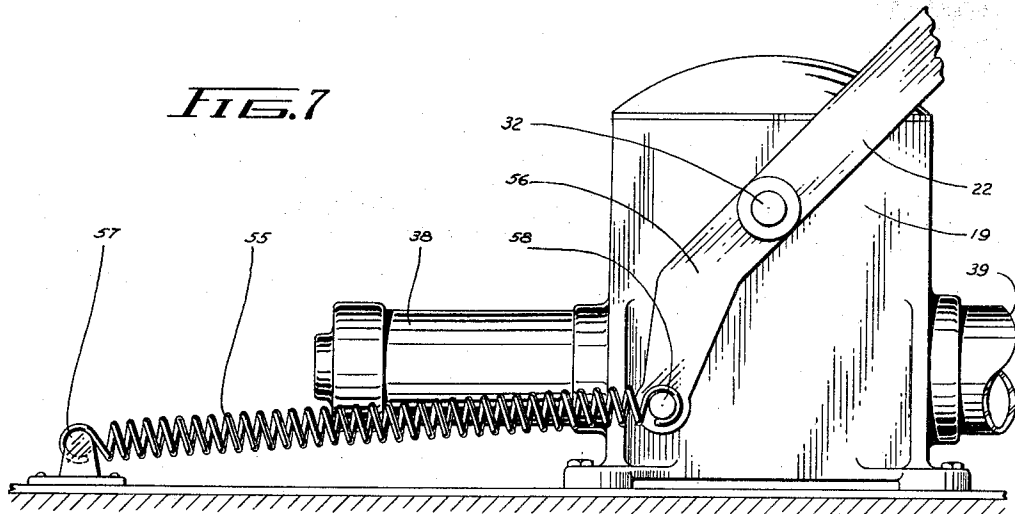

INVENTOR.
PAUL H. MAURER
BY *Martin J. Limegan*
ATTORNEY

1

2,710,186

DOOR OPERATION AND CONTROL

Paul H. Maurer, Wellesley, Mass., assignor, by mesne assignments, to National Pneumatic Co., Inc., Boston, Mass., a corporation of Delaware

Original application July 21, 1948, Serial No. 39,961, now Patent No. 2,578,894, dated December 18, 1951. Divided and this application November 19, 1951, Serial No. 257,003

3 Claims. (Cl. 268—50)

This invention relates to door operation and control, and particularly to a system providing mechanical power for automatically opening a door, and mechanical power for automatically closing the door, after an interval of definite or indefinite duration, according to the selection of the person supervising the operation.

One object of the invention is to provide a novel method of controlling the operation of a door, which novel method involves the utilization of two power applying agencies conjointly under normal circumstances, with one of said power applying agencies being adapted to operate the door in one direction independently of the other power applying agency, in the event of temporary absence of an energy supply for the latter agency.

In the embodiment of the invention chosen for exemplification purposes, one power applying agency is a fluid motor so constructed and connected as to apply operating power in two directions alternately, while the other power applying agency is a spring of lesser capacity than the fluid motor, and effective to apply door operating power in the door closing direction only; the spring normally assisting the fluid motor in closing the door, but being readily yieldable during operation of the fluid motor to open the door, or on any occasion of manual opening of the door, so that there is only a relatively slight increase of power necessary to offset the effect of the spring during the opening stage of the cycle.

Another object of the invention, therefore, is to provide a door operating motor assembly including a spring of insufficient capacity to be an appreciable obstacle to easy opening of the door, either by the motor or by hand, while at the same time being capable of effectively closing the door, independently of any other agency, on any occasion when the motor is not functioning normally.

A further object is to provide a door operating assembly including an operating linkage normally actuated by two power applying agencies during the door closing stage of the cycle, and by only one of said power applying agencies during the door opening stage of the cycle.

Another object is to provide an assembly including a fluid motor, and a spring to assist the motor in one direction of operation.

A further object is to provide, in a motor-spring combination of the character indicated, a novel inter-relationship between the motor and spring, including a door operating linkage to which said motor and spring are both connected, but at different locations, affording different leverage effects for each.

Other objects and features of the invention will be apparent upon examination of the following description of the embodiment illustrated in the accompanying drawings, this being one of many embodiments to which the invention lends itself; it being understood that all such alternative embodiments, including all or any lesser number of components which may incorporate any of the

2

principles of the disclosed invention, are embraced herein.

In the drawings:

Fig. 1 is an elevation view of a door operating motor and spring combination, embodying the invention, the motor and spring being shown in operating relationship to a door to be operated;

Fig. 2 is a sectional view along line 2—2 of Fig. 1;

Figs. 3 to 6, inclusive, are schematic illustrations showing how the motor responds to changes in the setting of a three-position control element;

Fig. 7 is a view, on a larger scale, of a portion of the motor and door actuating linkage, with the spring shown contracted; and

Fig. 8 is a similar view, but with the spring shown extended.

Referring first to Fig. 1, the door 11 is shown as equipped with hangers 12 including rollers movable along a rail 13, whereby the door may move between the closed position shown in full lines and the fully open position indicated by dash line 14 in Fig. 1. The door 11 also carries two finger-grip plates 17, 18 secured near its forward edge, each having a recess (see Fig. 2) facilitating manual sliding of the door to the open position, from either side thereof, in the event of non-functioning of the motor 19. Other parts carried by the door include a channel plate 21 receiving one end of line 22, a switch 23 for initiating operation of the motor 19, and a cable connection box 24 to which one end of cable 26 is attached; the said cable housing the leads 27, 28 of the electrical connections shown more completely in Figs. 3 and 4.

Motor 19 is shown as including a gear sector 31 secured to a rock shaft 32, to which is also secured the link 22 above referred to; also a rack 33 meshing with the teeth of sector 31 and reciprocable with a pair of pistons 36, 37 housed in cylinders 38, 39, respectively, the latter being attached to opposite sides of the central motor housing 19. Cylinders 38, 39 are illustrated as receiving compressed air or other operating fluid from a common feed line 41, the feeding and exhausting of such fluid being under the control of a pair of valves 42, 43, the former being spring-biased to a fluid feeding position and shiftable to a fluid exhausting position upon energization of solenoid winding 44, and the valve 43 being spring-biased to a fluid exhausting position and shiftable to a fluid feeding position upon energization of solenoid winding 45. Conduits 46, 47 lead from valves 42, 43, to the cylinders 39, 38 respectively, and a third conduit 48 connects valve 43 with the supply port of valve 42. The exhaust ports of the two valves are indicated at 51 and 52.

As previously indicated, the invention includes the use of auxiliary door closing means of lesser capacity than the motor 19, yet of sufficient capacity to close the door independently of said motor in the event of absence of pressure fluid for energization of the latter. As shown best in Figs. 7 and 8, the link 22 extends beyond the point of connection with motor shaft 32, and the extension 56 is made in the form of a bellcrank so that its outer end is off-set laterally from the longitudinal axis of the major portion of the link, to provide progressively increasing leverage action about the axis of shaft 32, which is the pivotal point of the linkage, as the linkage is shifted (by spring 55) from the "Door-open" position (Fig. 8); the locations of spring anchorage pins 57, 58, in relation to point 32 and to each other, being such that the applied closing force of the spring and lever combination is a minimum, at the commencement of the door closing swing of the lever, and increases progressively as the swing continues, reaching a maximum value as the door approaches the fully closed position. This mode of operation is of advantage, not

only when the spring is acting as the sole closing instrumentality (in emergencies when the motor 19 is not functioning normally) but also in the normal functioning of the spring as an auxiliary agency to supplement the action of the motor 19; for in executing such auxiliary function it is desirable that the spring provide greatest assistance toward the end of the stroke of the door closing piston 37, at which time the fluid pressure resistance to the piston's continued motion is greatest, as will appear more clearly hereinafter.

The application of pressure fluid to the pistons 36 and 37, of the motor 19, is under the direction of a delayed-action relay 61 (Figs. 3 and 4) operating in conjunction with the solenoid windings 44, 45, the initiating switch 23, and a three-position control switch 62; the latter permitting manual selection of one of three distinct modes of operation.

The three possible modes of operation of the apparatus, as illustrated and described above, will be described in sequence, as follows:

Operation A.—Opening and closing of the door by power applied to motor 19. Control switch 62 in "Automatic" position, bridging contacts 64, 65 (Figs. 3 and 4).

With control switch 62 in the "Automatic" position bridging contacts 64, 65, a circuit is completed from the source to the winding 45 of "pressure" magnet valve 43 to direct pressure fluid through the valves 43 and 42 in succession, and thus into both cylinders 38 and 39, through conduits 47 and 46, respectively, thus placing the system in condition for successive automatic opening and closing movements of the door 11; the door being now in the closed position, as the differential of pressure on pistons 36 and 37 is such as to hold said pistons in their extreme leftward position (Fig. 3).

Let it be supposed that, with the parts in the positions just indicated, a person desiring passage through the closed door 11 moves the door switch 23 to the closed position. This action produces a flow of current to the winding of relay 61, by way of conductors 27 and 28. Energization of the relay winding is immediately effective to snap the bridging members 65 and 67 of the relay into bridging relationship to contacts 68 and 69 respectively, which bridging relationship continues for three, four, five, or more seconds, according to the adjustment (not shown) of the delayed action dash-pot or other mechanism governing the return of the bridging member to their normal (non-bridging) position.

During the continuance of this bridging relationship of parts 66 and 67 to contacts 68, 69 respectively, current flows from the source to the winding 44 of "exhaust" magnet valve 42, the path of flow being by way of conductor 70, parts 69 and 67, and conductor 71. The result of this activation of valve 42 is to exhaust pressure fluid from cylinder 39, by way of conduit 46, whereupon pistons 36, 37 move from left to right (the pressure on the left side of piston 36 being now dominant) and causes the door 11 to swing from the closed position to the open position. Upon reaching such open position, striker 72 moves the switch 73 to the open position as shown in Fig. 4, thus breaking the holding circuit from the relay 61, whereupon (after the time delay has run its course) member 67 drops away from contact 69, thus de-energizing exhaust magnet 44. Pressure fluid instantly re-enters the line 46 and the cylinder 39, to the right of piston 37, moving the piston assembly 36, 37 to the left and thus returning the door 11 to its closed position. During such return spring 55 assists the piston 37, the amount of such assistance progressively increasing as the door progresses toward fully closed position as previously noted.

Operation B.—Causing the door to be held in the open position. Control switch 62 in "Remain open" position, bridging contacts 63, 64, 65 (Fig. 5).

When a train porter, or other person, desires to have the door open, and remain open for a period of un-

measured duration, the switch 62 can be thrown to the "Remain open" position, thus establishing a circuit from the source direct to the exhaust valve magnet winding 44, by way of bridged contacts 63, 64 of said switch 62. As this circuit maintains the valve 42 in a position which continuously vents cylinder 39 to the atmosphere, by way of conduit 46 and port 51, it will be apparent that once the door has been opened (as previously described) it will remain open because of the absence of any closing pressure fluid in cylinder 39; the spring 55 being of insufficient capacity to close the door of itself, so long as full air pressure is applied to piston 36.

Operation C.—Closing the door by the spring 55 alone. Control switch 62 in "manual opening" position, in which all three contacts 62, 63 and 64 remain unbridged (see Fig. 6).

Placing control switch 62 in its third position (Fig. 6) breaks the normally closed circuit from the source to the winding 45 of "pressure" magnet valve 43. This causes a shift of valve 43 to the fluid exhausting position, whereupon spring 55, after any manual opening of the door 11, will move the door back to the closed position, through the agency of the link 22, the latter also acting to move the pistons 36 and 37, all of which are now free of fluid pressure influences. As a result of this action of spring 55, the door is moved back to the closed position without any fluid pressure assistance, following any opening thereof manually, so long as switch 62 remains in this third position.

The spring 55 will also function as an automatic power closing agency for the door during any absence of effective electric current, for in either of these situations there will be no fluid-pressure inducted restriction on the free expansion of spring 55, following each compression thereof.

This application is a division of applicant's application Ser. No. 39,961 of July 21, 1948, now Patent 2,578,894 entitled "Door Operation and Control."

What I claim is:

1. In a door operating system, in combination, a door, a movable linkage connected thereto, operating means normally freely movable in either of two directions and connected to said linkage and, through said linkage, to said door, movement of said operating means in a first direction causing said door to open and movement of said operating means in a second direction causing said door to close, a spring positively connected to said linkage so as to constantly resiliently urge it to move so as to close said door and having a strength sufficient to close said door when no force is applied to said operating means, a source of power operatively connected to said operating means, and control means operatively connected to said source of power to selectively condition the latter to (a) exert a force on said operating means capable of overcoming the resistance of said spring and causing said operating means to move in said first direction until said door is open and then automatically exerting a force on said operating means causing said operating means to move in said second direction to close said door, (b) exert on said operating means a continuous force capable of overcoming the resistance of said spring and causing said operating means to move in said first direction until said door is open and then remain in said open position, and (c) exert no appreciable force on said operating means either to cause or to oppose motion in either direction, said operating means being then free to move in said second direction under the influence of said spring.

2. The door operating system of claim 1, in which said control means is electrically energized and includes a manually settable switch to condition said source of power to conditions (a) or (b), failure of electrical power thereto causing said source of power to be conditioned to condition (c).

3. The door operating system of claim 1, in which

5

said control means is electrically energized and includes a manually settable switch to condition said source of power to conditions (a), (b) or (c), failure of electrical power thereto causing said source of power to be conditioned to condition (c).

References Cited in the file of this patent

UNITED STATES PATENTS

2,254,388 Olcott ----- Sept. 2, 1941

2,388,182
2,504,408
2,558,867
2,573,160
5 2,578,894
2,578,909
2,586,442
2,606,022

6

Redding et al. ----- Oct. 30, 1945
Griffin ----- Apr. 18, 1950
May et al. ----- July 3, 1951
Norman ----- Oct. 30, 1951
Maurer ----- Dec. 18, 1951
Turner ----- Dec. 18, 1951
Seagren ----- Feb. 19, 1952
Vander Veer et al. ----- Aug. 5, 1952