

J. BURNS.
Tar and Petroleum Burners.

No. 140,465.

Patented July 1, 1873.

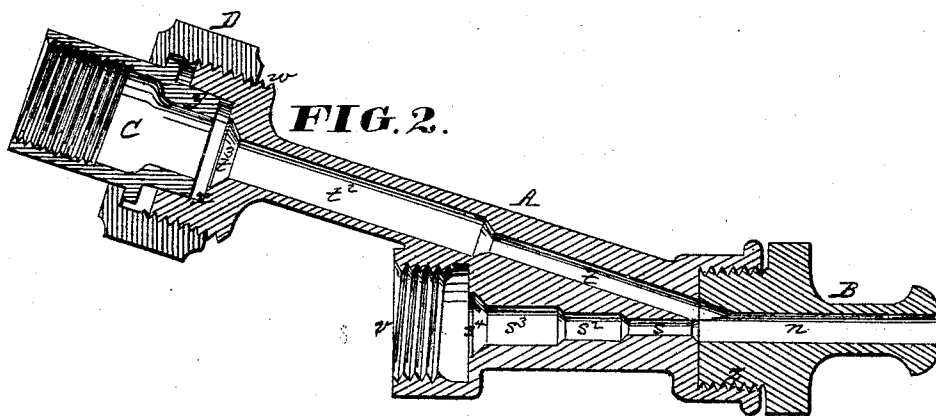
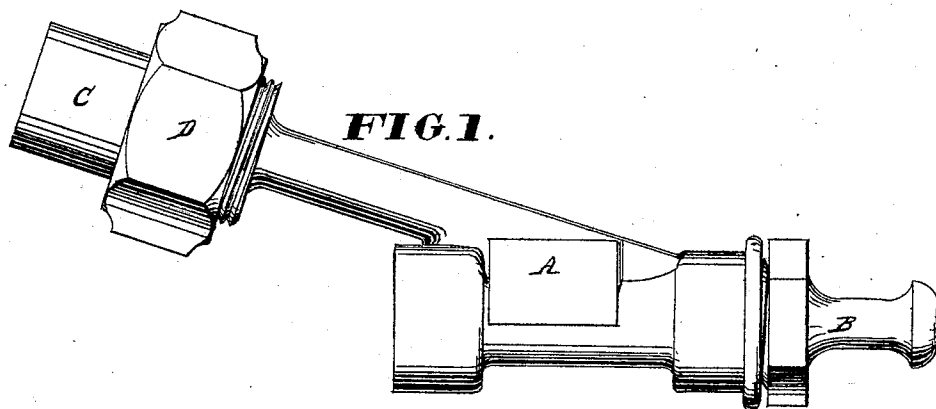

WITNESSES:
Chas. L. Quinn
Walter Allen

INVENTOR:
James Burns
By *Smith & Wray* Attorneys.

UNITED STATES PATENT OFFICE.

JAMES BURNS, OF LONDON, CANADA.

IMPROVEMENT IN TAR AND PETROLEUM BURNERS.

Specification forming part of Letters Patent No. **140,465**, dated July 1, 1873; application filed May 8, 1873.

To all whom it may concern:

Be it known that I, JAMES BURNS, of London, in the county of Middlesex, Province of Ontario, Dominion of Canada, have invented a certain Tar or Petroleum Burner, of which the following is a specification:

This invention relates to an apparatus for atomizing tar and crude petroleum, and supplying oxygen thereto by means of steam, so as to facilitate or render practicable the burning of these materials as fuel in furnaces. Various patterns of burners for this purpose have been devised. The objects of this invention are, first, to insure the union of the tar and steam in proper fixed proportion; second, to properly mingle the same in a simple straight nozzle; third, to provide for the support of the heavier tar particles by the steam until they are consumed; and thus to secure a more perfect combustion, and more heat from a given quantity of tar than has heretofore been accomplished. The invention consists in a very simple form of burner or atomizer having a horizontal, or nearly horizontal, steam-passage, an inclined tar-passage entering the former at top and toward the outlet, and a nozzle extending from the junction in line with the steam-passage, or nearly so, the same being made of certain fixed relative proportions, as hereinafter set forth.

Figure 1 is a side elevation of a tar-burner constructed according to this invention. Fig. 2 is a vertical longitudinal section of the same.

Referring to the drawing, A B represent two castings, of brass or other suitable metal, united by a screw-joint, *z*, and constituting the burner proper. C represents a collar for the end of a tar-pipe. *y* represents a conical extension of this nozzle, and *x* a conical cavity in the burner to receive the same to form a tight joint. D represents a screw-nut, swiveled to the collar C and engaging with a threaded neck, *w*, on the burner, within which the cavity *x* is concentrically formed. *v* represents a threaded socket, to receive the end of a steam-pipe. The casting B constitutes an adjustable and changeable nozzle, which is considered desirable, but not essential. If preferred the burner may be readily cast in one piece. *t* represents the effective tar-passage; *s*, the effective steam-passage; and *n*, the nozzle bore. These

bore should each be of uniform diameter throughout without taper or flare. t^2 and s^4 represent bore-sections, successively contracting the tar and steam columns to the diameters of the effective passages.

To insure the union of the tar and steam in proper fixed proportions, and so as to cause the tar to be perfectly atomized as proposed, certain relative sizes of passage, and size and length of nozzle bore, are found to be essential, namely, in a burner for a twenty-five to fifty horse-power steam-boiler furnace the diameter for tar-passage *t* is three-sixteenths inch; steam-passage *s* (one-third less) one-eighth inch; nozzle bore *n* (equal in capacity to the two passages, or nearly so,) one-quarter or five-sixteenths inch; and the length for nozzle bore is two inches, or less. For larger or smaller burners the measurements should be increased or diminished in the same relative proportions.

To provide for supporting the tar or oil in the furnace so as to secure the combustion of all the particles before they can fall, the steam-passage *s* and the nozzle bore *n* are arranged horizontally and in line, or nearly so, and the tar-passage *t* opens into this line at top, so as to cause the steam to receive the tar or oil as in a trough, and correspondingly to issue chiefly at the bottom of the jet, so as to carry upward and support the tar particles in the furnace. These infinitesimal tar particles, becoming ignited and supplied with oxygen by the steam, create an intense heat, and a perfect combustion of the steam as well as the tar results, the steam being present in properly limited quantity, and its temperature retained and increased to the requisite extent by the burning of the tar particles.

It will be observed that the objects of the improved burner are, first, to admit the tar and steam in proper relative proportions; second, to thoroughly mingle the same, but without attempt to vaporize the tar; third, to freely discharge the same in minute particles or atoms; fourth, to insure the support of the tar particles in the furnace until they are consumed.

The peculiar nozzle bore *n* is a primary and essential feature of the construction, by which the most important of these objects, namely, the second and third, and the successful oper-

ation of the burner, generally considered, are secured. The length of the bore insures the proper commingling of the steam and tar, while the relative size and shape of the bore preclude any retarding effect or back pressure.

The idea of burning mingled tar or oil and steam, and the combination in a burner of tar and steam passages, and a nozzle common to both are known to be old, and are disclaimed.

I am aware of the apparatus for vaporizing and burning hydrocarbons, subject-matter of patent No. 127,723, issued June 11, 1872, to Samuel J. Whiting, and hereby disclaim any feature of my atomizer which may appear to be included therein.

The following is claimed as new, namely:
The atomizer for burning tar or petroleum, comprising a tar-passage, *t*, a steam-passage, *s*, and a nozzle bore, *n*, in which these unite, the latter being equal, or nearly equal, in capacity to the two passages, and of uniform diameter throughout, and of suitable relative length, as herein described, for the objects set forth.

JAMES BURNS.

Witnesses:

EDWARD MEEK,
HENRY VIVIAN.