



(86) **Date de dépôt PCT/PCT Filing Date:** 2015/03/24
 (87) **Date publication PCT/PCT Publication Date:** 2015/10/01
 (85) **Entrée phase nationale/National Entry:** 2016/07/07
 (86) **N° demande PCT/PCT Application No.:** IB 2015/052139
 (87) **N° publication PCT/PCT Publication No.:** 2015/145346
 (30) **Priorité/Priority:** 2014/03/25 (IT VI2014A000074)

(51) **Cl.Int./Int.Cl. G03F 9/00** (2006.01),
B29C 67/00 (2006.01), **G06F 17/50** (2006.01)
 (71) **Demandeur/Applicant:**
 DWS S.R.L., IT
 (72) **Inventeur/Inventor:**
 MAROZIN, ALESSANDRO, IT
 (74) **Agent:** OSLER, HOSKIN & HARCOURT LLP

(54) **Titre : PROCEDE ET EQUIPEMENT PERMETTANT DE DEFINIR UNE STRUCTURE DE SOUTIEN POUR UN OBJET TRIDIMENSIONNEL A REALISER PAR STEREOGRAPHIE**
 (54) **Title: METHOD AND EQUIPMENT FOR DEFINING A SUPPORTING STRUCTURE FOR A THREE-DIMENSIONAL OBJECT TO BE MADE THROUGH STEREOGRAPHY**

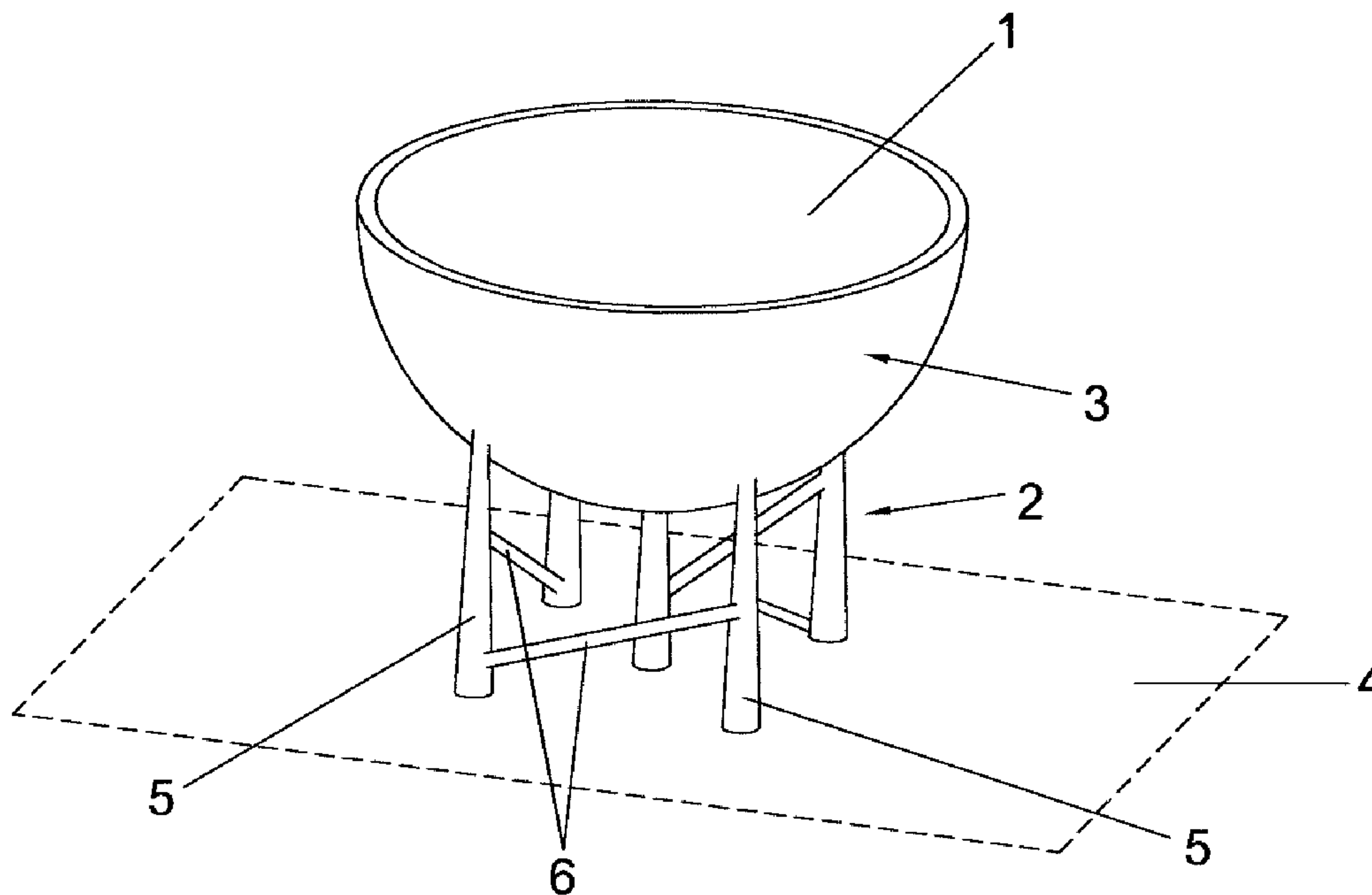

Fig.3

(57) **Abrégé/Abstract:**

The invention is a computer-implemented method for defining a supporting structure (2) for a three-dimensional object (1) to be produced through a stereolithography process, comprising the following operations: defining a first surface (3) to be supported of

(57) Abrégé(suite)/Abstract(continued):

the three-dimensional object (1) and a second surface (4) facing the first surface (3); defining elongated supporting elements (5) between the surfaces (3, 4); defining pairs of supporting elements (5); for each pair of supporting elements (5), defining an elongated reinforcing element (6) connecting the two supporting elements (5) of the pair. The definition of the pairs of supporting elements (5) comprises the following operations: defining a reference point (7) of each supporting element (5); defining a connected acyclic graph (8) having as vertices the reference points (7); for each edge (9) of the graph, defining one pair of supporting elements comprising the two supporting elements (5) corresponding to the ends of the edge (9). The definition of the pairs of supporting elements (5) comprises the further operation of defining an additional pair of supporting elements for each vertex having order 1 of the connected acyclic graph (8), the additional pair comprising a first supporting element (5) corresponding to the vertex having order 1 and a second supporting element (5) not connected to the first supporting element (5) through any edge (9).

(12) INTERNATIONAL APPLICATION PUBLISHED UNDER THE PATENT COOPERATION TREATY (PCT)

(19) World Intellectual Property
Organization
International Bureau(43) International Publication Date
1 October 2015 (01.10.2015)(10) International Publication Number
WO 2015/145346 A1

(51) International Patent Classification:

B29C 67/00 (2006.01) G06F 17/50 (2006.01)

(21) International Application Number:

PCT/IB2015/052139

(22) International Filing Date:

24 March 2015 (24.03.2015)

(25) Filing Language:

Italian

(26) Publication Language:

English

(30) Priority Data:

VI2014A000074 25 March 2014 (25.03.2014) IT

(71) Applicant: DWS S.R.L. [IT/IT]; Via Lago Di Levico, 3, I-36010 Zane' (VI) (IT).

(72) Inventor: MAROZIN, Alessandro; Via M. Guadagnin, 18/a, I-36042 Breganze (VI) (IT).

(74) Agent: MURARO, Alfeo; Studio Bonini Srl, Corso Fogazzaro, 8, I-36100 Vicenza (IT).

(81) Designated States (unless otherwise indicated, for every kind of national protection available): AE, AG, AL, AM, AO, AT, AU, AZ, BA, BB, BG, BH, BN, BR, BW, BY, BZ, CA, CH, CL, CN, CO, CR, CU, CZ, DE, DK, DM,

DO, DZ, EC, EE, EG, ES, FI, GB, GD, GE, GH, GM, GT, HN, HR, HU, ID, IL, IN, IR, IS, JP, KE, KG, KN, KP, KR, KZ, LA, LC, LK, LR, LS, LU, LY, MA, MD, ME, MG, MK, MN, MW, MX, MY, MZ, NA, NG, NI, NO, NZ, OM, PA, PE, PG, PH, PL, PT, QA, RO, RS, RU, RW, SA, SC, SD, SE, SG, SK, SL, SM, ST, SV, SY, TH, TJ, TM, TN, TR, TT, TZ, UA, UG, US, UZ, VC, VN, ZA, ZM, ZW.

(84) Designated States (unless otherwise indicated, for every kind of regional protection available): ARIPO (BW, GH, GM, KE, LR, LS, MW, MZ, NA, RW, SD, SL, ST, SZ, TZ, UG, ZM, ZW), Eurasian (AM, AZ, BY, KG, KZ, RU, TJ, TM), European (AL, AT, BE, BG, CH, CY, CZ, DE, DK, EE, ES, FI, FR, GB, GR, HR, HU, IE, IS, IT, LT, LU, LV, MC, MK, MT, NL, NO, PL, PT, RO, RS, SE, SI, SK, SM, TR), OAPI (BF, BJ, CF, CG, CI, CM, GA, GN, GQ, GW, KM, ML, MR, NE, SN, TD, TG).

Published:

— with international search report (Art. 21(3))

— before the expiration of the time limit for amending the claims and to be republished in the event of receipt of amendments (Rule 48.2(h))

(54) Title: METHOD AND EQUIPMENT FOR DEFINING A SUPPORTING STRUCTURE FOR A THREE-DIMENSIONAL OBJECT TO BE MADE THROUGH STEREO LITHOGRAPHY

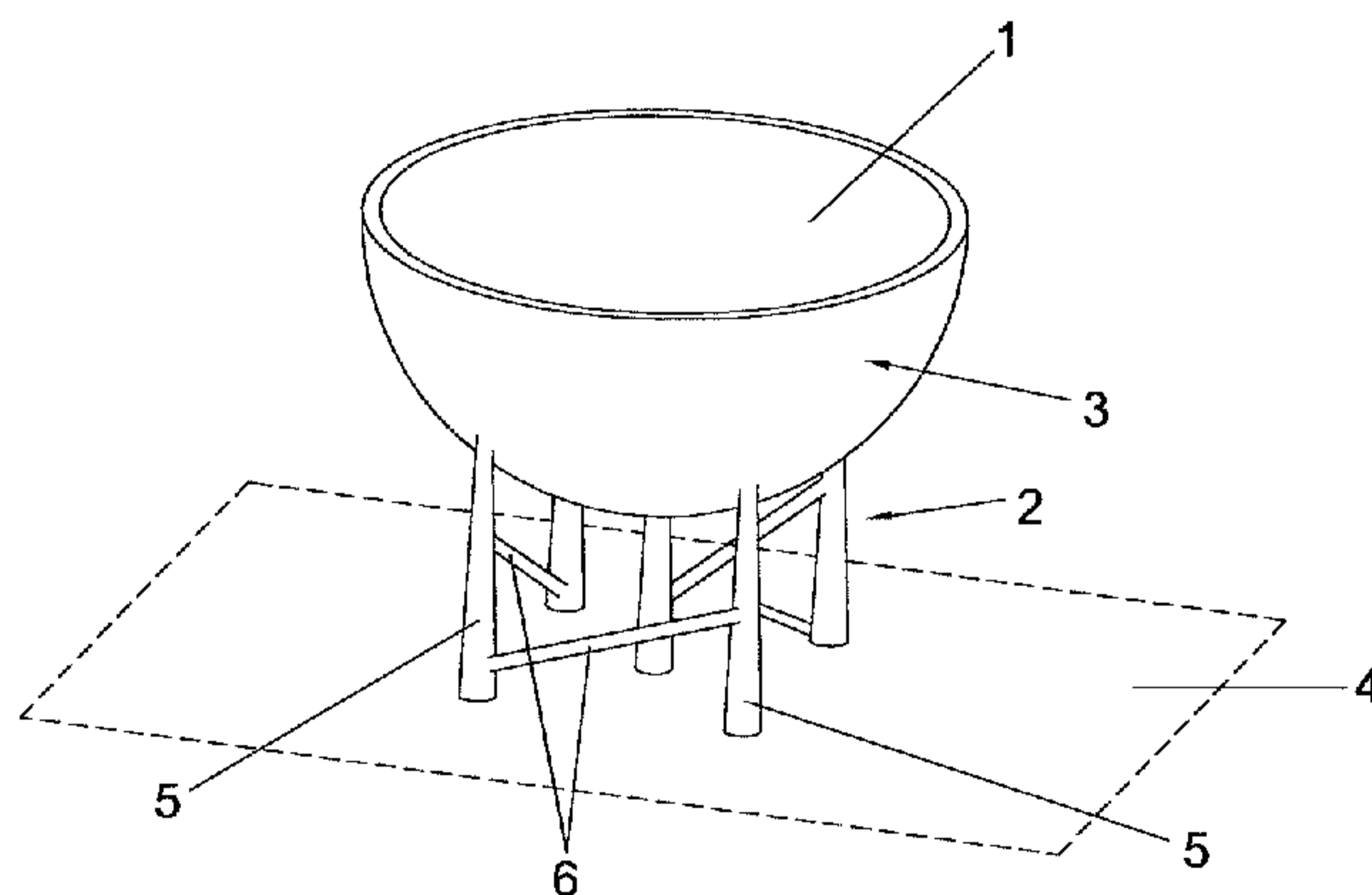

Fig.3

(57) Abstract: The invention is a computer-implemented method for defining a supporting structure (2) for a three-dimensional object (1) to be produced through a stereolithography process, comprising the following operations: defining a first surface (3) to be supported of the three-dimensional object (1) and a second surface (4) facing the first surface (3); defining elongated supporting elements (5) between the surfaces (3, 4); defining pairs of supporting elements (5); for each pair of supporting elements (5), defining an elongated reinforcing element (6) connecting the two supporting elements (5) of the pair. The definition of the pairs of supporting elements (5) comprises the following operations: defining a reference point (7) of each supporting element (5); defining a connected acyclic graph (8) having as vertices the reference points (7); for each edge (9) of the graph, defining one pair of supporting elements comprising the two supporting elements (5) corresponding to the ends of the edge (9). The definition of the pairs of supporting elements (5) comprises the further operation of defining an additional pair of supporting elements for each vertex having order 1 of the connected acyclic graph (8), the additional pair comprising a first supporting element (5) corresponding to the vertex having order 1 and a second supporting element (5) not connected to the first supporting element (5) through any edge (9).



WO 2015/145346 A1

METHOD AND EQUIPMENT FOR DEFINING A SUPPORTING STRUCTURE FOR A THREE-DIMENSIONAL OBJECT TO BE MADE THROUGH STEREOLITHOGRAPHY.

FIELD OF THE INVENTION

5

The present invention concerns a method and a piece of equipment for defining a supporting structure for a three-dimensional object to be made through stereolithography.

BACKGROUND OF THE INVENTION

10

As is known, a stereolithography process consists in making a three-dimensional object through the sequential superimposition of a plurality of layers of the object itself.

15

Each layer of the object is obtained through solidification of a material in the liquid or paste state, which occurs through selective exposure to light radiation.

Typically, the material is a plastic-based compound that polymerizes when it is reached by said light radiation.

20

The solidification of each successive layer of the object takes place in contact with the previous solidified layer, which serves as a support for the successive layer.

The process is controlled by a computer, which is supplied with a first set of data representative of the three-dimensional geometry of the object to be made.

25

The computer determines the geometry of the different layers of the object and consequently controls a stereolithography device.

30

Generally, according to the process a supporting structure is also added to the three-dimensional object before its actual production, wherein said supporting structure is solidified at the same time as the object during the stereolithography process.

Said supporting structure supports those portions of the layers to be solidified that, not being supported directly by the already solidified layers, may collapse or be permanently deformed during the process of production of the object.

5 The definition of the supporting structure is performed by said computer, in which a program is loaded that adds the elements of the supporting structure more or less automatically and generates a second set of data representative of the three-dimensional geometry resulting from the union of the three-dimensional object with the supporting structure itself.

10 Said second set of data is then used to define the geometry of the layers of the three-dimensional object.

The supporting structure comprises a plurality of supporting elements that connect one
15 or more surfaces to be supported of the three-dimensional object to corresponding surfaces that face the first ones and are intended to be made before them during the stereolithography process.

20 European application EP 1120228 A2 discloses a method to create the above support structure.

According to a variant of the supporting structure, reinforcing elements are also provided that connect said supporting elements with one another.

25 The reinforcing elements make the supporting structure sturdier and therefore reduce the risk of collapse of the three-dimensional object during the production step.

30 According to a known method for defining the supporting structure based on said variant, the supporting structure is defined as a three-dimensional grid that has a predefined shape and is substantially independent of the geometry of the three-dimensional object.

Successively, the elements of the grid that would intersect the three-dimensional object are removed, maintaining only the elements of the grid that are located outside the object itself.

5 That which remains of the grid is connected to the three-dimensional object through further connection elements, in such a way as to obtain a single object.

Said known method poses the drawback that it does not allow the supporting structure to be defined in an optimal way.

10

In fact, since the grid of the supporting structure is defined in a manner that is substantially independent of the three-dimensional object, the structure may be undersized or, vice versa, oversized with respect to the structural needs of the object itself.

15 An undersized supporting structure poses the drawback that its overall volume is not sufficient to properly serve the function of supporting the three-dimensional object.

On the contrary, an oversized supporting structure has an excessively large overall volume.

20

As the time required by the stereolithography process increases proportionally to the volume to be solidified, an oversized supporting structure negatively affects the overall time required to produce the three-dimensional object.

25 Furthermore, the larger the volume of the supporting structure, the larger the quantity of material necessary for its production, with the inconvenience of increasing the overall cost of the three-dimensional object.

30 An oversized supporting structure may also result from an excessively thick grid, with the further inconvenience of hindering the cleaning operations to be carried out on the three-dimensional object at the end of the stereolithography process.

In fact, it is known that an object obtained through stereolithography is washed at the end of the stereolithography process, in such a way as to remove the residues of non-solidified material.

5 Said washing operation is performed before separating the supporting structure from the three-dimensional object.

Therefore, the supporting structure hinders the flow of washing fluid on some surfaces of the three-dimensional object and the thicker the grid that defines the structure, the more
10 considerable this hindering effect.

Pu Huang, in "Algorithm for Layered Manufacturing in Image Space – Master Thesis", published in October 2012 by The Chinese University of Hong Kong, discloses an algorithm for building a support structure, the algorithm involving defining a graph the
15 nodes of which correspond to the anchors of the structure, the graph being used to define connections between the anchors.

The present invention intends to overcome all the drawbacks mentioned above related to the supporting structures of known type.

20

SUMMARY OF THE INVENTION

In particular, it is the object of the present invention to provide a supporting structure for a three-dimensional object to be produced through stereolithography having a suitable
25 strength, yet having a smaller overall volume compared to that obtainable with the methods of known type described above.

In accordance with one embodiment of the present invention, there is provided a computer-implemented method for defining a supporting structure for a three-dimensional
30 object to be produced through a stereolithography process, comprising the following operations: defining a first surface to be supported belonging to the three-dimensional object; defining a second surface facing the first surface; defining a plurality of supporting

elements having an elongated shape and extending from the first surface to the second surface; defining a plurality of pairs of the supporting elements; for each pair of the plurality of pairs of supporting elements, defining at least one reinforcing element having an elongated shape and connecting the two supporting elements of the pair; the operation
5 of defining the plurality of pairs of supporting elements comprising the following operations: defining a reference point belonging to each one of the supporting elements; defining a connected acyclic graph having as vertices the reference points and comprising corresponding edges between the vertices; defining one of the pairs of supporting elements for each one of the edges, the pair comprising the two supporting elements
10 corresponding to the ends of the edge; wherein the operation of defining the plurality of pairs of supporting elements comprises the further operation of defining an additional pair of supporting elements for each vertex having order 1 of the connected acyclic graph, the additional pair comprising a first supporting element corresponding to the vertex having order 1 and a second one of the supporting elements not connected to the first supporting
15 element through any of the edges.

In accordance with another embodiment of the present invention, there is provided equipment for defining a supporting structure for a three-dimensional object to be produced through a stereolithography process, comprising: a computer comprising a
20 processing unit and a memory support accessible by the processing unit; means for acquiring a first set of data representative of the geometry of the three-dimensional object and for loading the first set of data in the memory support; means for defining a first surface to be supported belonging to the three-dimensional object; means for defining a second surface facing the first surface; means for defining a plurality of supporting
25 elements having an elongated shape and extending from the first surface to the second surface; means for defining a plurality of pairs of the supporting elements; means for defining, for each pair of the plurality of pairs of supporting elements, at least one reinforcing element having an elongated shape and connecting the two corresponding supporting elements; means for generating a second set of data representative of the
30 geometry resulting from the union of the supporting elements and the reinforcing elements with the three-dimensional object and for loading the second set of data in the memory support; the means for defining the plurality of pairs of supporting elements

comprising: means for defining a reference point belonging to each one of the supporting elements; means for defining a connected acyclic graph having as vertices the reference points and comprising corresponding edges between the vertices; means for defining one pair of supporting elements for each one of the edges, the pair comprising the two supporting elements corresponding to the ends of the edge; wherein the means for defining the plurality of pairs of supporting elements are configured so as to define an additional pair of supporting elements for each vertex having order 1 of the connected acyclic graph, the additional pair comprising a first supporting element corresponding to the vertex having order 1 and a second one of the supporting elements not connected to the first supporting element through any of the edges.

Another embodiment of the present invention provides a computer program product comprising a data support provided with program portions configured in such a way that, when executed on a computer comprising a processing unit and a memory support accessible by the processing unit, the program portions define: means for acquiring a first set of data representative of the geometry of the three-dimensional object and for loading the first set of data in the memory support; means for defining a first surface to be supported belonging to the three-dimensional object; means for defining a second surface facing the first surface; means for defining a plurality of supporting elements having an elongated shape and extending from the first surface to the second surface; means for defining a plurality of pairs of the supporting elements; means for defining, for each pair of the plurality of pairs of supporting elements, at least one reinforcing element having an elongated shape and connecting the two corresponding supporting elements; means for generating a second set of data representative of the geometry resulting from the union of the supporting elements and the reinforcing elements with the three-dimensional object and for loading the second set of data in the memory support; the means for defining the plurality of pairs of supporting elements comprising: means for defining a reference point belonging to each one of the supporting elements; means for defining a connected acyclic graph having as vertices the reference points and comprising corresponding edges between the vertices; means for defining one pair of supporting elements for each one of the edges, the pair comprising the two supporting elements corresponding to the ends of the edge; wherein the means for defining the plurality of pairs of supporting elements are

configured so as to define an additional pair of supporting elements for each vertex having order 1 of the connected acyclic graph, the additional pair comprising a first supporting element corresponding to the vertex having order 1 and a second one of the supporting elements not connected to the first supporting element through any of the edges.

5

Advantageously, the possibility to produce a specific supporting structure for each three-dimensional object ensures that the supporting structure is suitable for the structural needs of the object.

10 Furthermore, advantageously, this also prevents said supporting structure from being oversized, thus limiting the volume of the structure itself.

The reduced volume of the supporting structure advantageously leads to a reduction in both the overall time required to make the three-dimensional object by means of the stereolithography process and the quantity of material necessary for the processing, and
15 therefore in the cost of the object itself.

Furthermore, advantageously, the smaller volume of the supporting structure makes it easier to wash the three-dimensional object once it has been completed.

20

BRIEF DESCRIPTION OF THE DRAWINGS

Said objects and advantages, together with others that are highlighted here below, will be illustrated in the descriptions of some preferred embodiments of the invention that are
25 provided by way of non-limiting examples with reference to the attached drawings, wherein:

Figure 1 shows an axonometric view of an example of three-dimensional object to be made through stereolithography;

30

Figure 2 shows an object obtained by joining the three-dimensional object of Figure 1 and a part of the supporting structure according to the invention;

Figure 3 shows an object obtained by joining the three- dimensional object of Figure 1 and the supporting structure according to the invention;

Figure 4 shows a diagram of the links between the elements of the supporting structure of Figure 3, in plan view;

Figure 5 shows a diagram of the links related to a variant of the supporting structure of Figure 3, in plan view;

Figure 6 shows a variant of the supporting structure of Figure 3;

Figure 7 shows a variant of the supporting structure of Figure 6.

DETAILED DESCRIPTION

The method of the invention for defining a supporting structure for a three-dimensional object to be made through stereolithography is described with reference to the three-dimensional object represented in Figure 1 and indicated therein by 1.

It should be noted since now that the three-dimensional object 1 has been purposely represented with a very simplified geometry compared to the objects that are commonly produced through stereolithography, in order to make the drawings clearer.

It is evident, however, that the description provided above can be analogously applied to a three-dimensional object with any geometry.

First of all the method includes the step of defining a first surface 3 to be supported, belonging to the three-dimensional object 1.

Obviously, a plurality of said first surfaces to be supported can be defined depending on the geometry of the object, the material used for the stereolithography process and other parameters, if necessary.

Obviously, the method of the invention can be applied to each one of said first surfaces.

According to the method, for each first surface **3** a second surface **4**, facing the first one, is defined.

5

The second surface **4** can be separate from the three-dimensional object **1**, as in the case shown in the figures.

As an alternative, the second surface **4** may belong to the three-dimensional object **1**.

10

The first option is suitable for a first surface **3** intended to be arranged so that it faces the modelling plate that supports the three-dimensional object **1** during its production, with no need to interpose other parts of the object itself.

15 In particular, the second surface **4** can be defined in such a way that during the actual production of the three-dimensional object it coincides with the surface of said modelling plate.

This last case is the one illustrated in Figures 2 and 3, in which said second surface **4** is
20 hatched.

According to the variant embodiment shown in Figure 6, the second surface **4** belongs to a supporting base **11** intended to be arranged in contact with said modelling plate. This variant is described in greater detail below.

25

When, instead, the first surface **3** is arranged in a cavity of the three-dimensional object **1** or, in any case, faces another surface of the object itself, the second surface **4** preferably belongs to the object.

30 In the latter case, the second surface **4** is preferably the surface of the three-dimensional object **1** that directly faces the first surface **3**, for example the surface of said cavity that is opposite the first surface **3**.

Obviously, in a single three-dimensional object **1** there may be a combination of the cases described above.

Once the first surface **3** and the second surface **4** have been defined, the method includes
5 the step of defining a plurality of supporting elements **5** in an elongated shape, extending from the first surface **3** to the second surface **4**, as shown in Figure 2.

Analogously to that which has already been remarked, it should be pointed out that the
10 supporting elements **5** shown in Figure 2 have been purposely represented in a reduced number in order to simplify the representation.

It is however evident that, in general, the number of supporting elements will be higher than that shown in the figures and will depend on the geometry of the object and on other
15 parameters.

In general, the number of supporting elements will be higher than two and in most cases
higher than three.

Notwithstanding the above, the method described herein can be applied in any case,
20 independently of the number of supporting elements provided.

Preferably but not necessarily, said supporting elements **5** are conical or cylindrical in shape, but they can obviously be also in other shapes.

25 The supporting elements **5** can also be provided with branches at one or both ends, in such a way as to be connected to the corresponding surface in several points. This type of branching is not represented in the figures, but is known per se.

Preferably, each supporting element **5** has a thinner portion located at the level of the first
30 surface **3** and/or of the second surface **4**, not represented in the figures, but known per se.

Said thinner portion offers the advantage of favouring the detachment of the supporting element **5** from the surfaces **3** and/or **4** once the stereolithography process during which the three-dimensional object **1** is actually produced has been completed.

5 The method also includes the operation of defining, for each pair of supporting elements **5**, one or more reinforcing elements **6** in an elongated shape, preferably conical or cylindrical, that connect the two supporting elements **5** of said pair, as shown in Figure 3.

To advantage, said reinforcing elements **6** make it possible to increase the resistance of
10 the supporting structure **2** while maintaining the same overall volume of the latter or, alternatively, to reduce the volume of the supporting structure **2** while ensuring the same degree of resistance.

According to the invention, the pairs of supporting elements **5** to be connected to said
15 reinforcing elements **6** are selected with the aid of the well-known graph theory.

In particular, the method includes the operation of defining a reference point **7** belonging to each supporting element **5**.

20 A connected acyclic graph is then generated whose vertices are the reference points **7**. As is known, a graph is a mathematical construction consisting of one pair of sets V and E , wherein the elements of the first set V are points in space, called "vertices", while the elements of the second set E represent a corresponding number of links between pairs of vertices, which are called "edges".

25

Therefore, in mathematical notation, a graph G is expressed with the following relation

$$G = (V, E).$$

30 From a formal point of view, an edge that connects two generic vertices u and v is represented by the pair (u, v) of the vertices themselves.

Clearly, given a set of vertices V , there is an infinity of possible graphs comprising said set V , which differ from one another for the set of edges E .

5 The requisite that the graph be a connected acyclic graph limits said graphs to a finite number.

In particular, the requisite that the graph be connected implies that for any two vertices of the graph there is a succession of edges that connect them.

10 The requisite that the graph be acyclic implies that any two vertices are connected through one and only one succession of edges.

In the theory of graphs, a connected acyclic graph of the type mentioned above is also called a "tree".

15 Advantageously, the connected acyclic graphs corresponding to a given set of vertices can be identified through suitable algorithms that are known per se.

20 Figure 4 shows a schematic plan view of a connected acyclic graph **8** whose vertices are the reference points **7**, which obviously is only one of the possible graphs having said properties.

In particular, each edge **9** of the graph **8** is represented in Figure 4 by a dashed segment that extends between the respective reference points **7**.

25 According to the method of the invention, the pairs of supporting elements **5** to be connected are identified by means of said connected acyclic graph **8**.

30 In particular, for each edge **9** of the graph **8** a pair is defined that comprises the two supporting elements **5** corresponding to the ends of the edge **9** itself.

By defining the pairs of supporting elements **5** in the manner described above, it is possible to achieve the purpose of limiting the volume of the supporting structure **2** with respect to those obtainable with the known methods.

5 In fact, as is known from the theory of graphs, connected acyclic graphs are those graphs which, among all the graphs that can be defined on the same vertices, have the lowest number of edges, while at the same time maintaining all the vertices connected to one another.

10 In particular, the number of edges of a connected acyclic graph is equal to the number of vertices minus one.

Therefore, for a given number of reinforcing elements **6** between each pair of supporting elements **5**, the definition of the pairs of supporting elements **5** as described above makes
15 it possible to limit the number of links between said supporting elements and, therefore, the number of reinforcing elements **6**, while at the same time maintaining all the supporting elements **5** connected to one another so as to obtain a stable supporting structure **2**.

20 Advantageously, using the theory of graphs to define the pairs of reinforcing elements **5** makes it possible to use said known algorithms to generate a connected acyclic graph **8**.

Preferably, for one or more pairs of supporting elements **5** a plurality of distinct reinforcing elements **6** is defined, which are indicatively shown in Figure 3.

25 Advantageously, the presence of several reinforcing elements **6** for one pair of supporting elements **5** makes it possible to obtain a more stable connection between the supporting elements **5**, especially when these are particularly long.

30 Consequently, to advantage, also the supporting structure **2** is more stable.

Obviously, in variant embodiments of the invention, the number of reinforcing elements **6** that connect a given pair of supporting elements **5** can be any and, moreover, it can vary in the different pairs of supporting elements **5**.

5 Preferably, but not necessarily, the reinforcing elements **6** that connect each pair of supporting elements **5** are arranged according to mutually incident directions, in such a way as to define a sort of lattice, thus further increasing the stability of the connection.

10 Preferably, said connected acyclic graph **8** is defined in such a way that it coincides with the minimum spanning tree of a complete graph having the same vertices as the connected acyclic graph **8** and in which each edge is associated with a weight corresponding to the distance between the ends of the edge itself.

15 More precisely, it is known that a complete graph is a graph in which any pair of vertices is connected by at least one edge.

As is also known, the minimum spanning tree of a graph can be defined only after assigning a weight to each edge of the graph itself, as it is defined as that specific subset of the graph for which the sum of said weights is minimal.

20 In particular, if the weights are selected in such a way as to represent the lengths of the edges as described above, the minimum spanning tree corresponds to the tree whose edges have the minimum overall length.

25 Therefore, the criterion just described above to define the pairs of supporting elements **5** allows to obtain a supporting structure **2** in which the reinforcing elements **6** extend over the shortest possible path.

30 Consequently, to advantage, it is possible to minimize the volume of the supporting structure **2** while maintaining the same number of reinforcing elements **6** between each pair of supporting elements **5**.

Advantageously, said minimum spanning tree can be defined using mathematical algorithms known in the theory of graphs.

5 According to construction variants of the invention, said weights can be defined in a different manner from that which has been described above.

For example, it may be appropriate to connect one or more pairs of supporting elements **5** with reinforcing elements developed according to curved trajectories and/or broken lines. In this case, the edges are assigned corresponding weights equal to the lengths of
10 the corresponding trajectories.

According to a construction variant of the invention, an additional pair of supporting elements **5** is defined at the level of each vertex having order 1 of the connected acyclic graph **8**.

15 In particular, said additional pair comprises a first supporting element **5** corresponding to said vertex having order 1 and a second supporting element **5** corresponding to a vertex of the graph **8** not connected to the first vertex.

20 As is known, a vertex having order 1 is defined as a vertex appearing in only one edge of the graph, meaning a vertex connected to one and only one vertex of the graph.

Therefore, it can be understood that the definition of the additional pair described above advantageously implies that any supporting element **5** is connected to at least other two
25 supporting elements **5**, with the advantage of increasing the overall structural resistance of the supporting structure **2**.

Indicatively, a possible additional pair is represented in Figure 5 and indicated therein by the reference number **10**.

30

Preferably, said additional pair is defined in such a way that the distance between the corresponding vertices of the connected acyclic graph **8** is the minimum possible distance.

5 Advantageously, the condition just described above makes it possible to limit to the minimum the length of the reinforcing elements **6** used to connect said additional pairs of supporting elements **5**.

10 Preferably, the additional pairs are defined between two supporting elements **5**, both corresponding to vertices of order 1, in such a way as to minimize the number of additional pairs introduced.

As already mentioned, Figure 6 represents a construction variant of the invention in which the second surface **4** is separate from the three-dimensional object **1**.

15

In particular, all of the reinforcing elements **6** lie on said second surface **4** and, therefore, connect the ends of the supporting elements **5**.

20 Said configuration is such that the reinforcing elements **6** define a supporting base **11** suited to be arranged in contact with the modelling plate of the stereolithography machine in order to support the three-dimensional object **1**.

25 Advantageously, a supporting base **11** shaped as described above has a much smaller volume than the supporting bases usually provided, which extend also over areas that are not affected by the presence of the supporting elements **5**.

Preferably, the second surface **4** is planar, so that said supporting base **11** can adapt to a modelling plate provided with a planar surface, which corresponds to the type of modelling plate commonly used.

30

The supporting base **11** represented in Figure 6 is defined by reinforcing elements **6** that extend between the supporting elements **5** according to the same links represented in Figure 4.

5 Figure 7 represents a further construction variant of the invention, in which the supporting base **11** has the same links shown in Figure 5.

This variant differs from the one shown in Figure 6 due to the presence of an additional link between the supporting elements **5**, corresponding to that indicated with the reference
10 number **10** in Figure 5.

According to the above, it can be understood that the graphs that can be obtained with the method according to the several variants described above can be used to make both a supporting structure **2** with a lattice-type configuration of the type shown in Figure 3 and
15 a supporting base **11** of the type shown in Figures 6 and 7.

Obviously, in variant embodiments of the invention the supporting structure **2** can be provided with both types of reinforcing elements **6**, not necessarily based on the same pairs of supporting elements **5**.

20 As regards the definition of the reference points **7**, this is preferably carried out through the definition of a preferably planar reference surface intersecting all the supporting elements **5**.

25 Each reference point **7** is defined in such a way that it belongs to the intersection area between the corresponding supporting element **5** and the reference surface.

Preferably, the reference surface is defined in such a way that it passes through the supporting elements **5** at the height of the respective median points.

30 According to a variant embodiment, the reference surface is defined in such a way that it coincides with the first surface **3** or with the second surface **4**.

A further construction variant includes the definition of a reference surface in the manner described above and then the definition of a supporting point belonging to the area of intersection between each supporting element **5** and the reference surface.

- 5 Each one of said supporting points is projected on a predefined, preferably planar projection surface, in such a way as to obtain a corresponding reference point **7**.

The projection surface may coincide with the first surface **3** or with the second surface **4**. The method described above can be applied also to several groups of supporting
10 elements **5**, wherein the reinforcing elements **6** connect the supporting elements **5** within each group, but do not connect the groups with one another.

In this case, the method is applied separately to each group of supporting elements **5** in order to generate the respective connected acyclic graphs **8**.

15 This variant can advantageously be applied to the case in which there are groups of supporting elements **5** relatively close to one another, but at the same time far away from the other supporting elements **5**, since this avoids the presence of excessively long reinforcing elements **6**, with no need to neglect the internal stability of each group.

20 The method described so far is preferably implemented by means of a piece of equipment comprising a computer, not represented in the figures but known per se, provided with a processing unit and a memory support that can be accessed by said processing unit.

- 25 Said equipment comprises means for acquiring a first set of data representative of the geometry of the three-dimensional object **1** and loading it in said memory support.

The equipment furthermore comprises means for defining the first surface **3** to be supported and means for defining the respective second surface **4**.

30

The equipment furthermore comprises means for defining the supporting elements **5**, means for defining the pairs of supporting elements **5** and means for defining the reinforcing elements **6** between said pairs.

5 The equipment also comprises means for generating a second set of data representative of the geometry resulting from the union of the supporting elements **5** and the reinforcing elements **6** with the three-dimensional object **1** and for loading said second set of data in the memory support.

10 According to the invention, the means for defining the pairs of supporting elements **5** comprise means for defining a reference point **7** belonging to each supporting element **5**, means for defining said connected acyclic graph **8** and means for defining one pair of supporting elements for each edge **9** of said connected acyclic graph **8** as described above.

15 Said equipment is preferably configured by means of a computer program product comprising a data support provided with program portions configured in such a way that, when executed on said computer, they define the means of the equipment as described above.

20 According to the explanations provided above, it can be understood that the method, the equipment and the computer program product described above achieve all of the set objects.

25 In particular, the invention makes it possible to obtain a supporting structure having a reduced volume compared to the supporting structures defined according to the known art.

30

The embodiments of the present invention for which an exclusive property or privilege is claimed are defined as follows:

1. A computer-implemented method for defining a supporting structure for a three-dimensional object to be produced through a stereolithography process, comprising the following operations:

defining a first surface to be supported belonging to said three-dimensional object;

defining a second surface facing said first surface;

defining a plurality of supporting elements having an elongated shape and extending from said first surface to said second surface;

defining a plurality of pairs of said supporting elements;

for each pair of said plurality of pairs of supporting elements, defining at least one reinforcing element having an elongated shape and connecting the two supporting elements of said pair;

said operation of defining said plurality of pairs of supporting elements comprising the following operations:

defining a reference point belonging to each one of said supporting elements;

defining a connected acyclic graph having as vertices said reference points and comprising corresponding edges between said vertices;

defining one of said pairs of supporting elements for each one of said edges, said pair comprising the two supporting elements corresponding to the ends of said edge;

wherein said operation of defining said plurality of pairs of supporting elements comprises the further operation of defining an additional pair of supporting elements for each vertex having order 1 of said connected acyclic graph, said additional pair comprising a first supporting element corresponding to said vertex having order 1 and a second one of said supporting elements not connected to said first supporting element through any of said edges.

2. The method according to claim 1, wherein said connected acyclic graph is defined in such a way that it coincides with a minimum spanning tree of a complete graph having the same vertices as said connected acyclic graph and in which each edge is assigned a weight equal to the value of the distance between the ends of said edge.

3. The method according to claim 1 or 2, wherein said additional pairs are defined in such a way that the sum of the distances between the corresponding vertices of said connected acyclic graph is minimal.

4. The method according to any one of claims 1 to 3, wherein said operation of defining said at least one reinforcing element includes the operation of defining a plurality of said reinforcing elements distinct from one another for at least one pair of said plurality of pairs of supporting elements.

5. The method according to any one of claims 1 to 5, wherein said second surface belongs to said three-dimensional object.

6. The method according to any one of claims 1 to 4, wherein said second surface is separate from said three-dimensional object and all of said reinforcing elements lie on said second surface.

7. The method according to claim 6, wherein said second surface is planar.

8. The method according to any one of claims 1 to 7, wherein each one of said supporting elements has a corresponding thinner portion located at a level of the first surface or of the corresponding second surface.

9. The method according to any one of claims 1 to 8, wherein said reinforcing elements have a conical or cylindrical shape.

10. The method according to any one of claims 1 to 9, wherein said definition of said reference points comprises the following operations:

defining a reference surface intersecting all of said supporting elements;

for each supporting element, defining a corresponding reference point in the area of intersection between said supporting element and said reference surface.

11. The method according to any one of claims 1 to 9, wherein said definition of said reference points comprises the following operations:

defining a reference surface intersecting all of said supporting elements;

defining a support point in the area of intersection between each supporting element and said reference surface;

defining a projection surface;

defining each one of said reference points as the projection of a corresponding one of said support points on said projection surface.

12. The method according to claim 10 or 11, wherein said reference surface coincides with said first surface or with said second surface.

13. Equipment for defining a supporting structure for a three-dimensional object to be produced through a stereolithography process, comprising:

a computer comprising a processing unit and a memory support accessible by said processing unit;

means for acquiring a first set of data representative of the geometry of said three-dimensional object and for loading said first set of data in said memory support;

means for defining a first surface to be supported belonging to said three-dimensional object;

means for defining a second surface facing said first surface;

means for defining a plurality of supporting elements having an elongated shape and extending from said first surface to said second surface;

means for defining a plurality of pairs of said supporting elements;

means for defining, for each pair of said plurality of pairs of supporting elements, at least one reinforcing element having an elongated shape and connecting the two corresponding supporting elements;

means for generating a second set of data representative of the geometry resulting from the union of said supporting elements and said reinforcing elements with said three-dimensional object and for loading said second set of data in said memory support;

said means for defining said plurality of pairs of supporting elements comprising:

means for defining a reference point belonging to each one of said supporting elements;

means for defining a connected acyclic graph having as vertices said reference points and comprising corresponding edges between said vertices;

means for defining one pair of supporting elements for each one of said edges, said pair comprising the two supporting elements corresponding to the ends of said edge;

wherein said means for defining said plurality of pairs of supporting elements are configured so as to define an additional pair of supporting elements for each vertex having order 1 of said connected acyclic graph, said additional pair comprising a first supporting element corresponding to said vertex having order 1 and a second one of said supporting elements not connected to said first supporting element through any of said edges.

14. A computer program product comprising a data support provided with program portions configured in such a way that, when executed on a computer comprising a processing unit and a memory support accessible by said processing unit, said program portions define:

means for acquiring a first set of data representative of the geometry of said three-dimensional object and for loading said first set of data in said memory support;

means for defining a first surface to be supported belonging to said three-dimensional object;

means for defining a second surface facing said first surface;

means for defining a plurality of supporting elements having an elongated shape and extending from said first surface to said second surface;

means for defining a plurality of pairs of said supporting elements;

means for defining, for each pair of said plurality of pairs of supporting elements, at least one reinforcing element having an elongated shape and connecting the two corresponding supporting elements;

means for generating a second set of data representative of the geometry resulting from the union of said supporting elements and said reinforcing elements with said three-dimensional object and for loading said second set of data in said memory support;

said means for defining said plurality of pairs of supporting elements comprising:

means for defining a reference point belonging to each one of said supporting elements;

means for defining a connected acyclic graph having as vertices said reference points and comprising corresponding edges between said vertices;

means for defining one pair of supporting elements for each one of said edges, said pair comprising the two supporting elements corresponding to the ends of said edge;

wherein said means for defining said plurality of pairs of supporting elements are configured so as to define an additional pair of supporting elements for each vertex having order 1 of said connected acyclic graph, said additional pair comprising a first supporting element corresponding to said vertex having order 1 and a second one of said supporting elements not connected to said first supporting element through any of said edges.

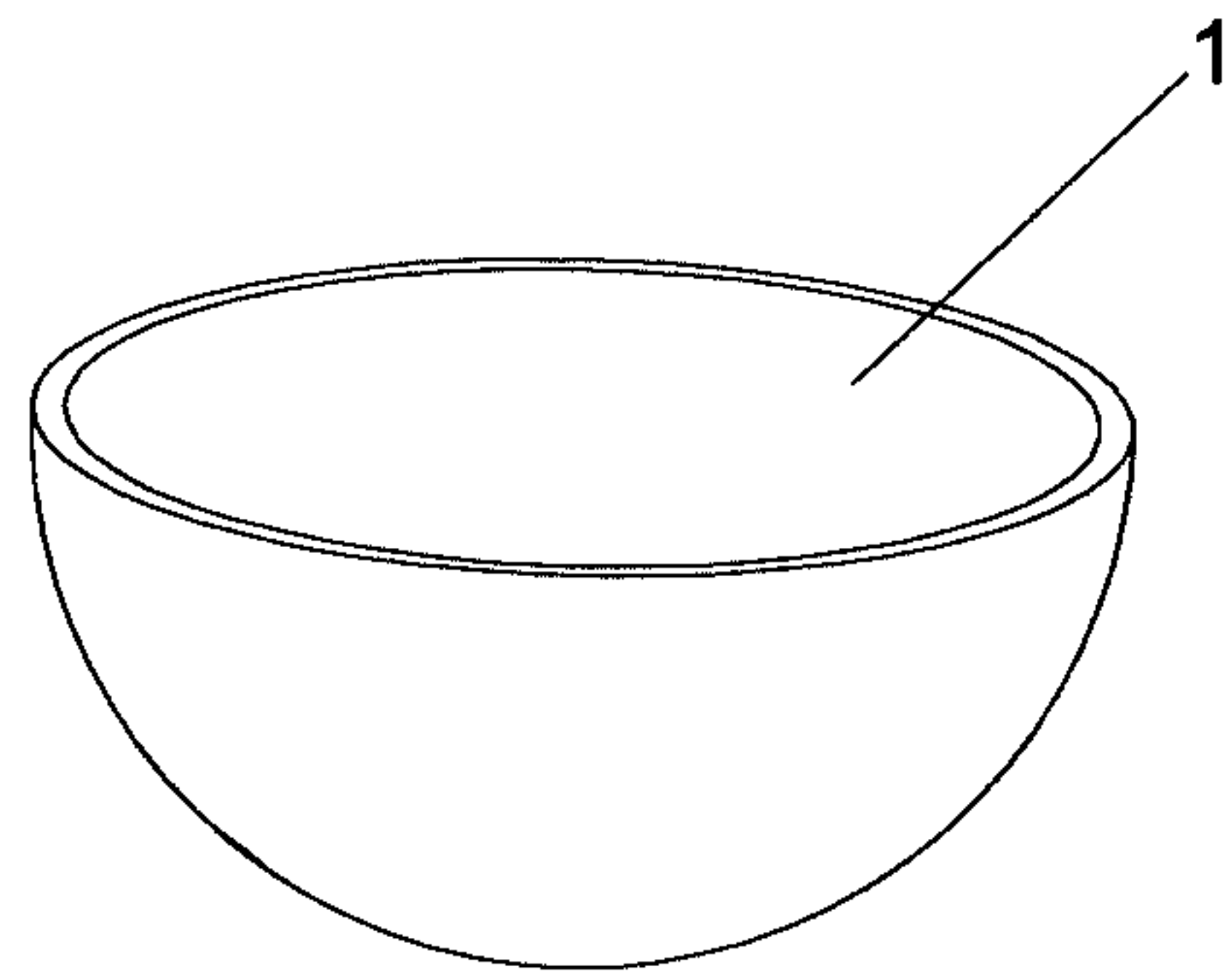

Fig.1

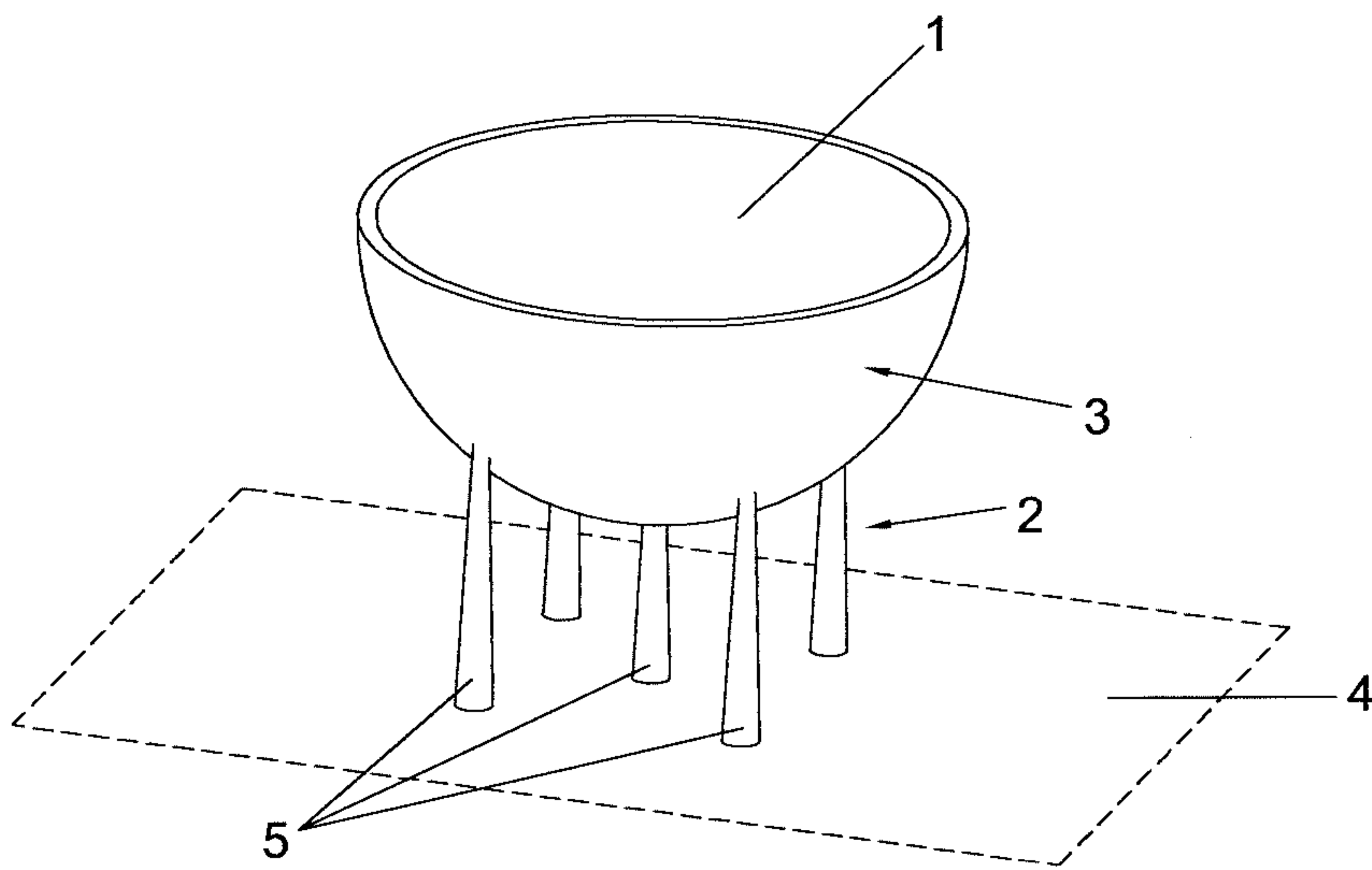

Fig.2

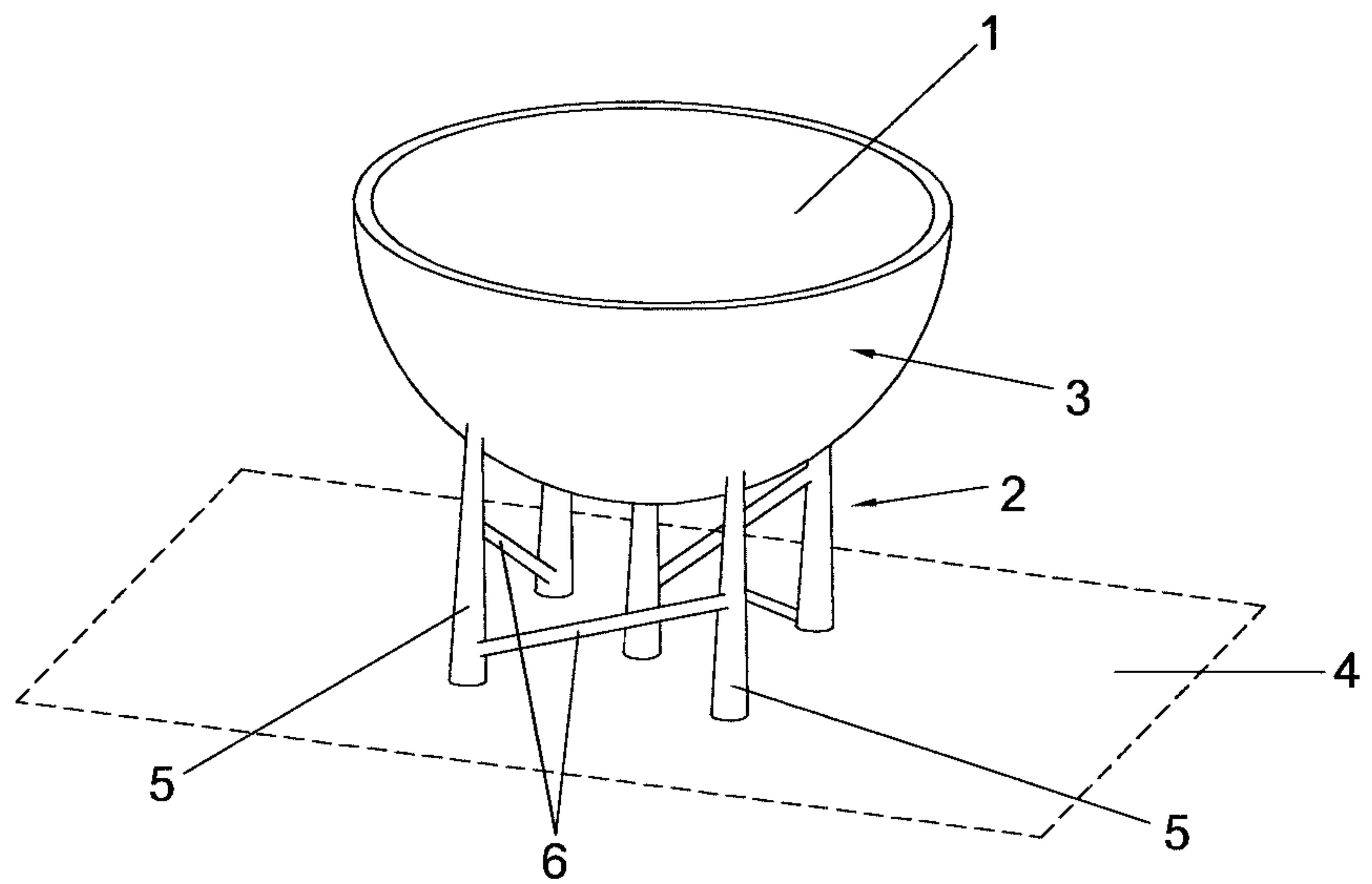

Fig.3

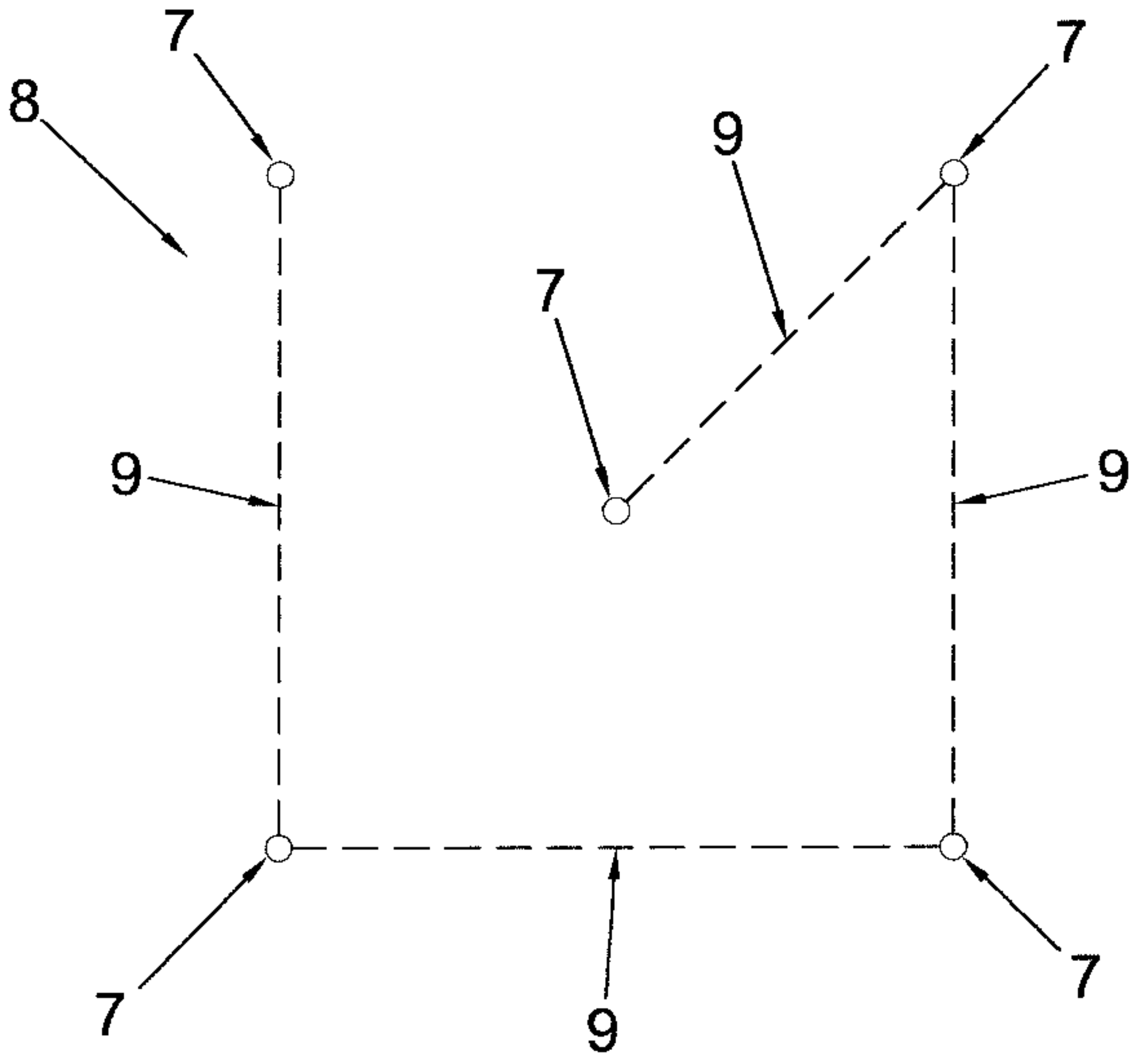

Fig.4

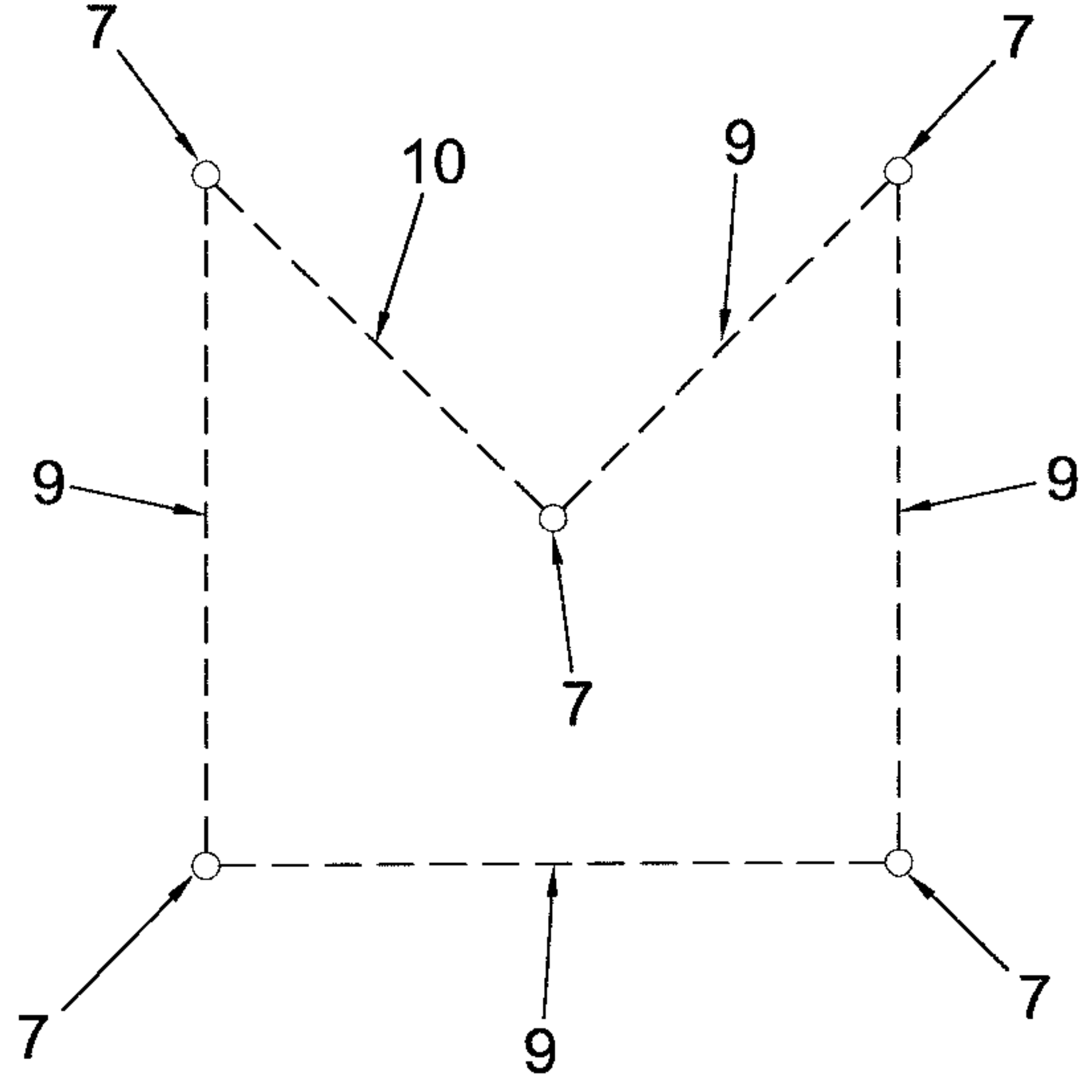

Fig.5

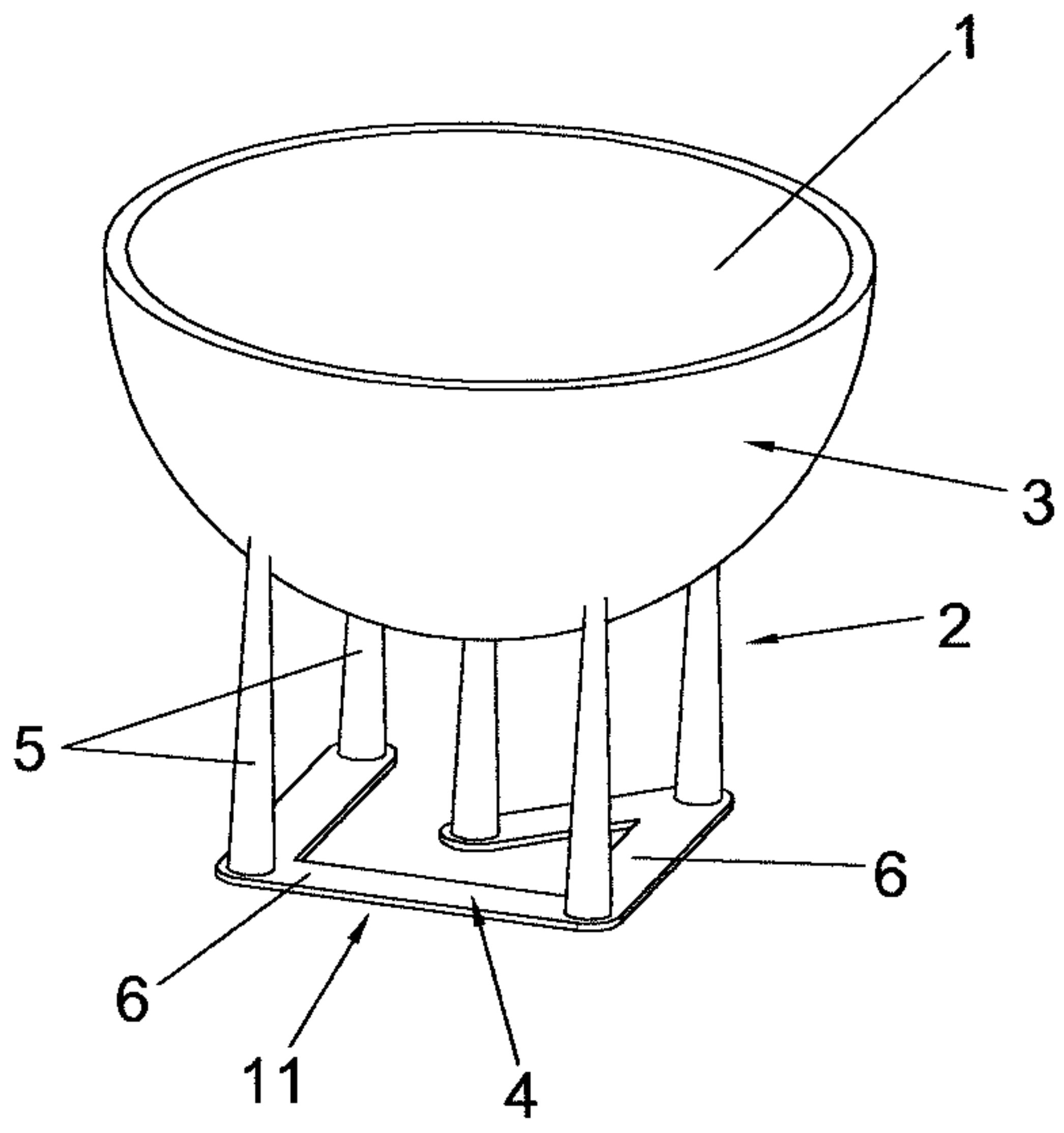

Fig.6

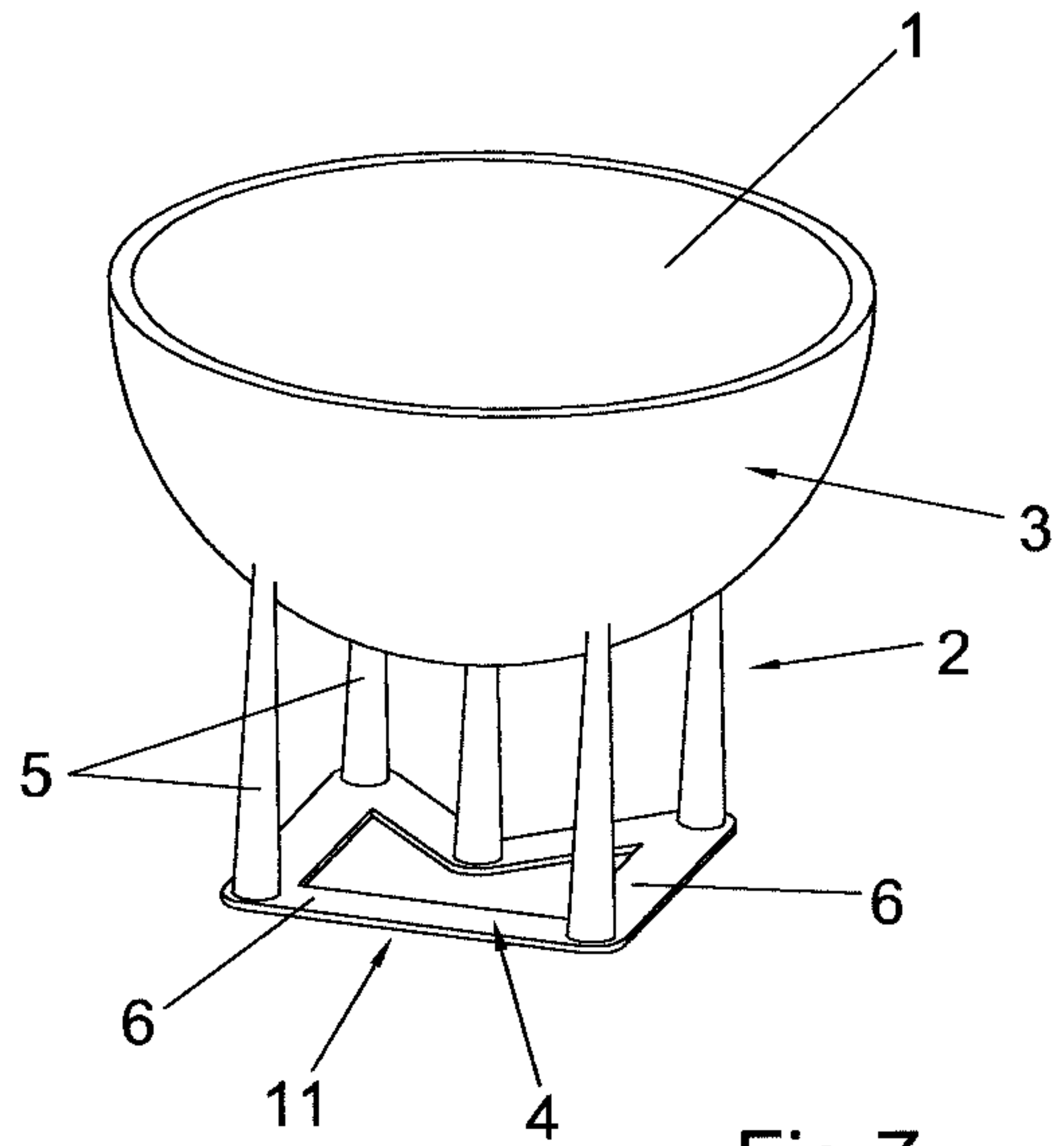

Fig.7

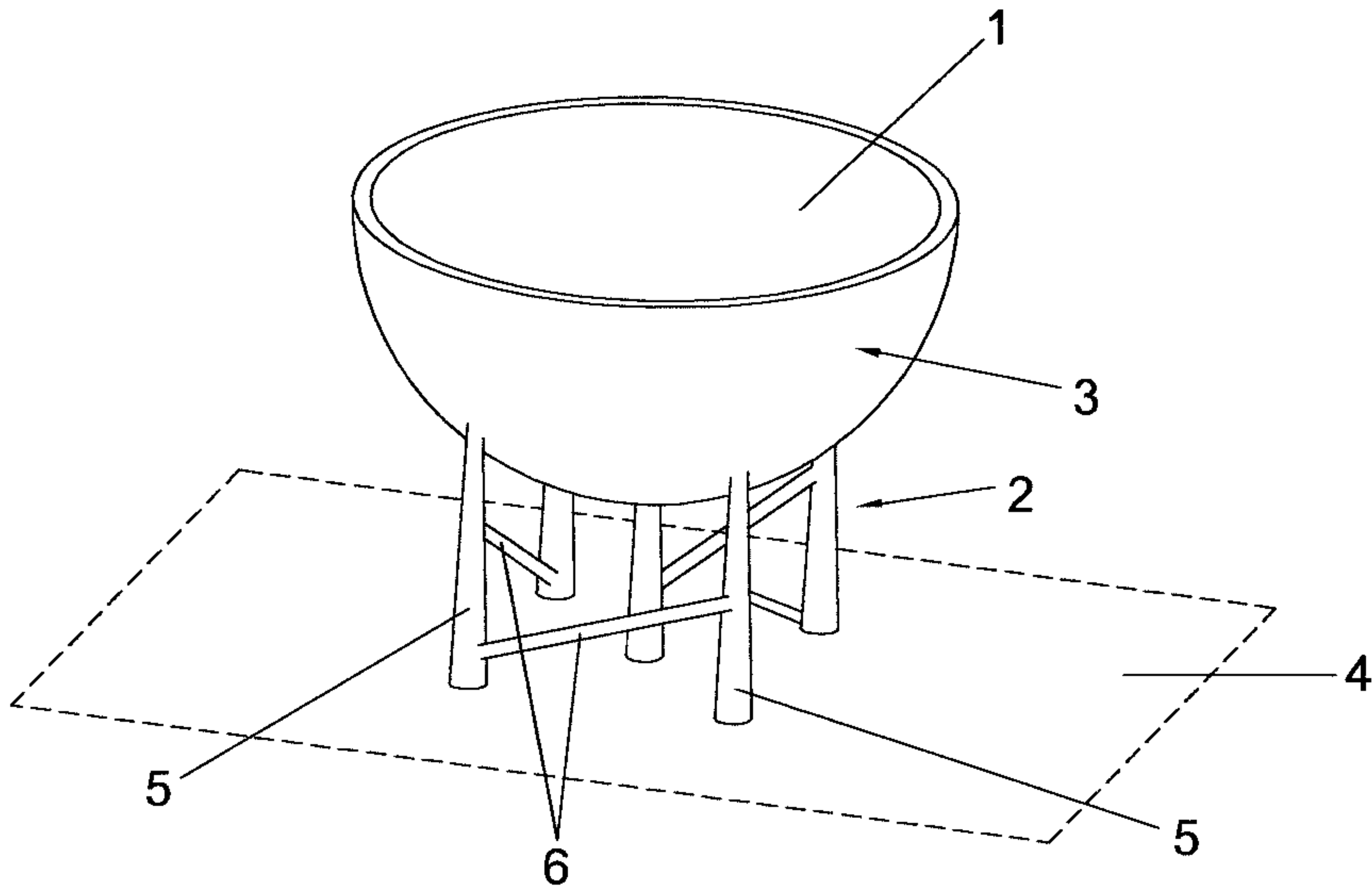

Fig.3