



US 20060152210A1

(19) **United States**

(12) **Patent Application Publication**  
**Mangtani et al.**

(10) **Pub. No.: US 2006/0152210 A1**

(43) **Pub. Date: Jul. 13, 2006**

(54) **CURRENT SENSOR**

**Publication Classification**

(75) Inventors: **Vijay Mangtani**, Nashua, NH (US);  
**Michael C. Doogue**, Manchester, NH  
(US); **William P. Taylor**, Amherst, NH  
(US)

(51) **Int. Cl.**  
**H01L 23/02** (2006.01)  
**G01R 33/07** (2006.01)  
**G01R 15/20** (2006.01)  
**H01L 23/495** (2006.01)

(52) **U.S. Cl.** ..... **324/117 H; 174/536**

Correspondence Address:  
**DALY, CROWLEY, MOFFORD & DURKEE,**  
**LLP**  
**SUITE 301A**  
**354A TURNPIKE STREET**  
**CANTON, MA 02021-2714 (US)**

(57) **ABSTRACT**

(73) Assignee: **Allegro Microsystems, Inc.**

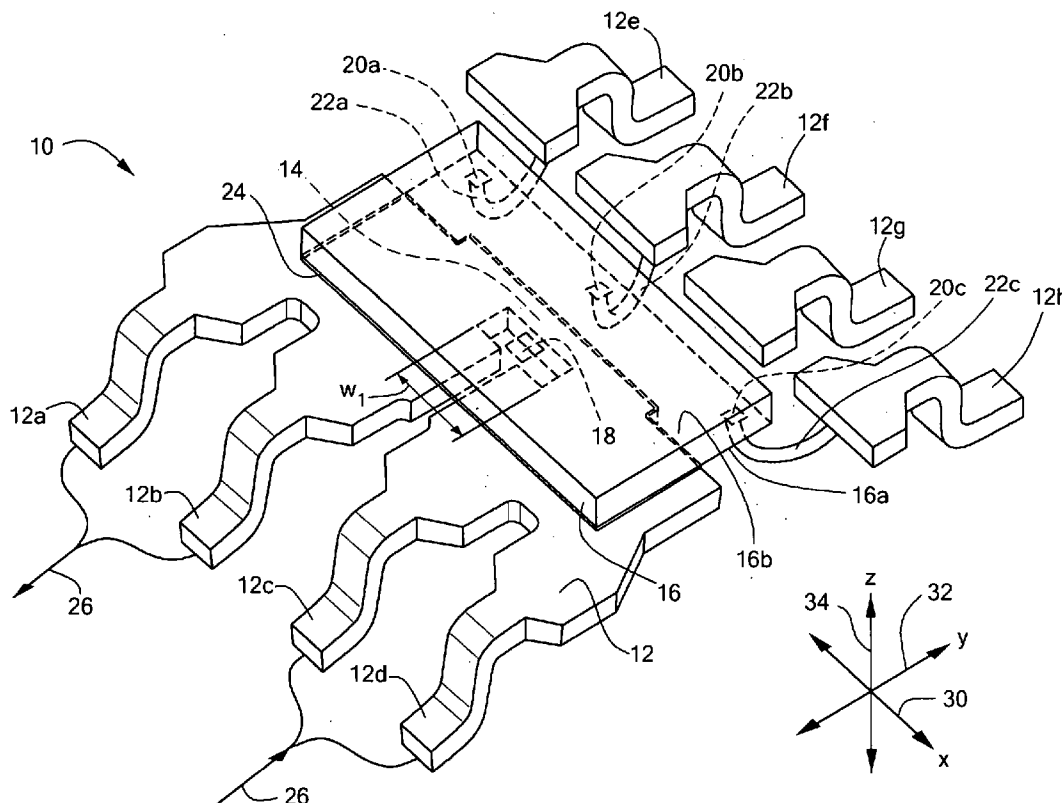
(21) Appl. No.: **11/336,602**

(22) Filed: **Jan. 20, 2006**

**Related U.S. Application Data**

(63) Continuation-in-part of application No. 11/144,970, filed on Jun. 3, 2005, which is a continuation-in-part of application No. 11/140,250, filed on May 27, 2005, now Pat. No. 6,995,315, which is a continuation-in-part of application No. 10/649,450, filed on Aug. 26, 2003.

An integrated circuit current sensor includes a lead frame having at least two leads coupled to provide a current conductor portion, and a substrate having a first surface in which is disposed one or more magnetic field sensing elements, with the first surface being proximate to the current conductor portion and a second surface distal from the current conductor portion. In one particular embodiment, the substrate is disposed having the first surface of the substrate above the current conductor portion and the second surface of the substrate above the first surface. In this particular embodiment, the substrate is oriented upside-down in the integrated circuit in a flip-chip arrangement. The integrated circuit includes an overcurrent circuit responsive to a voltage drop generated by a current.



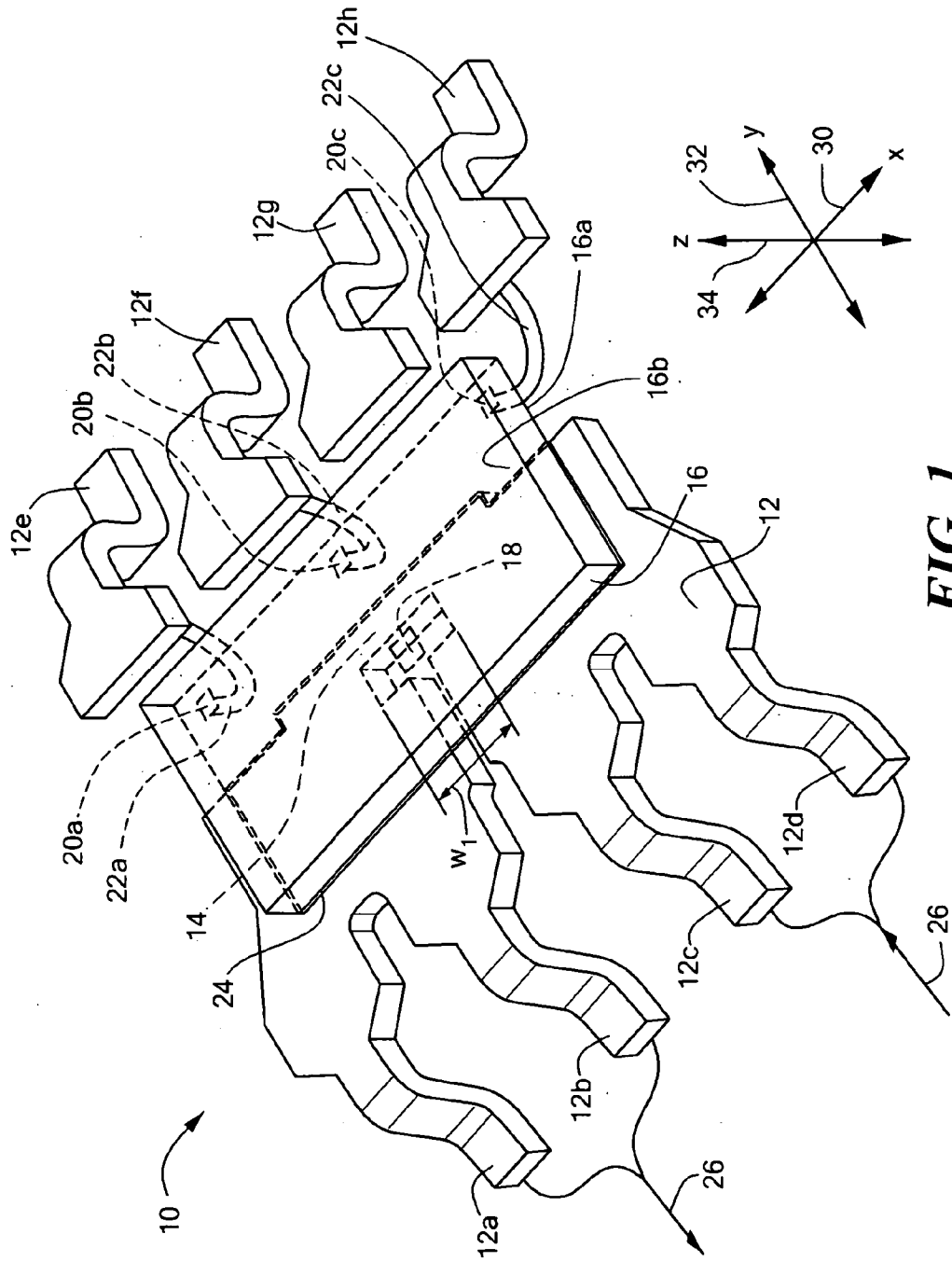
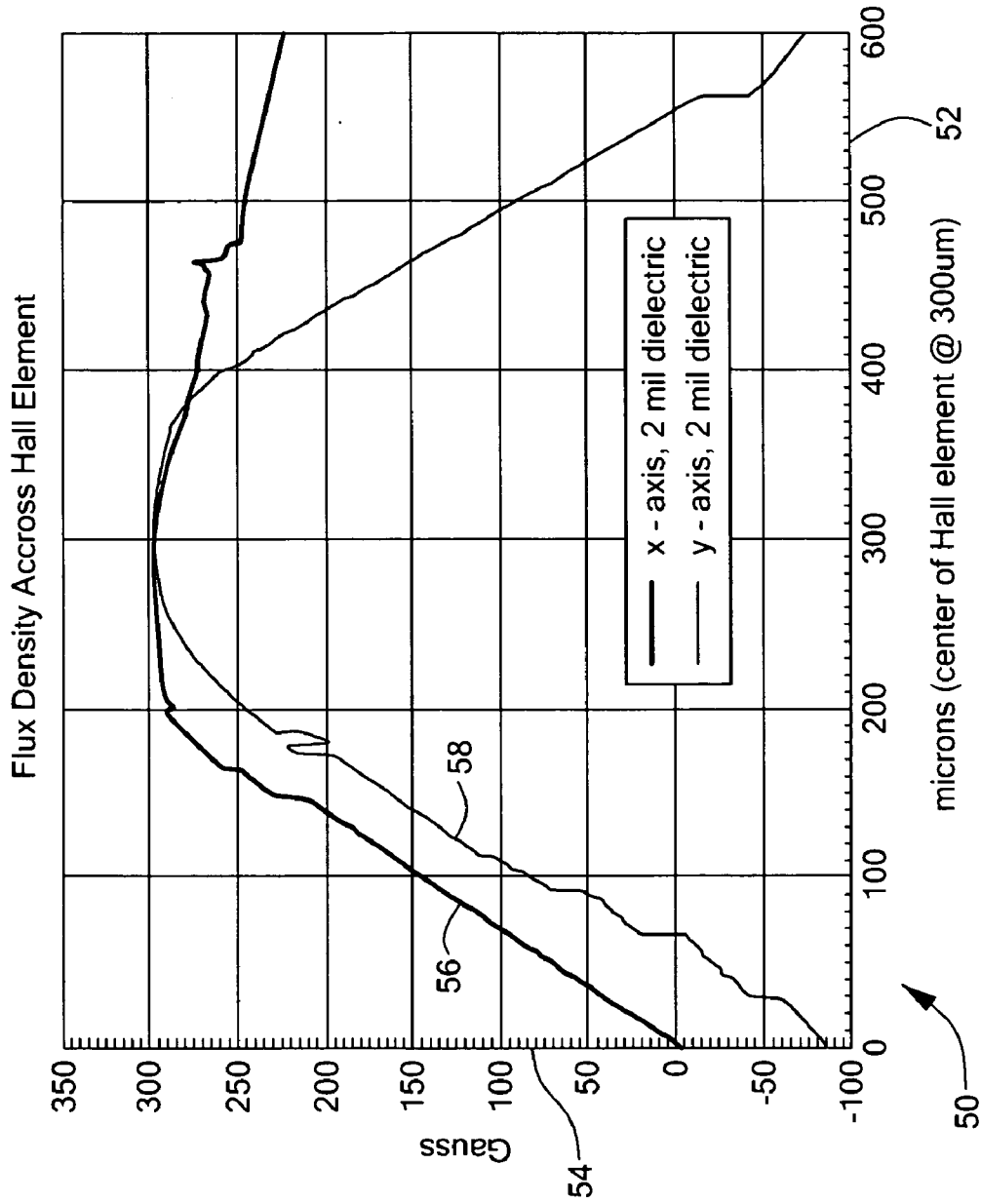
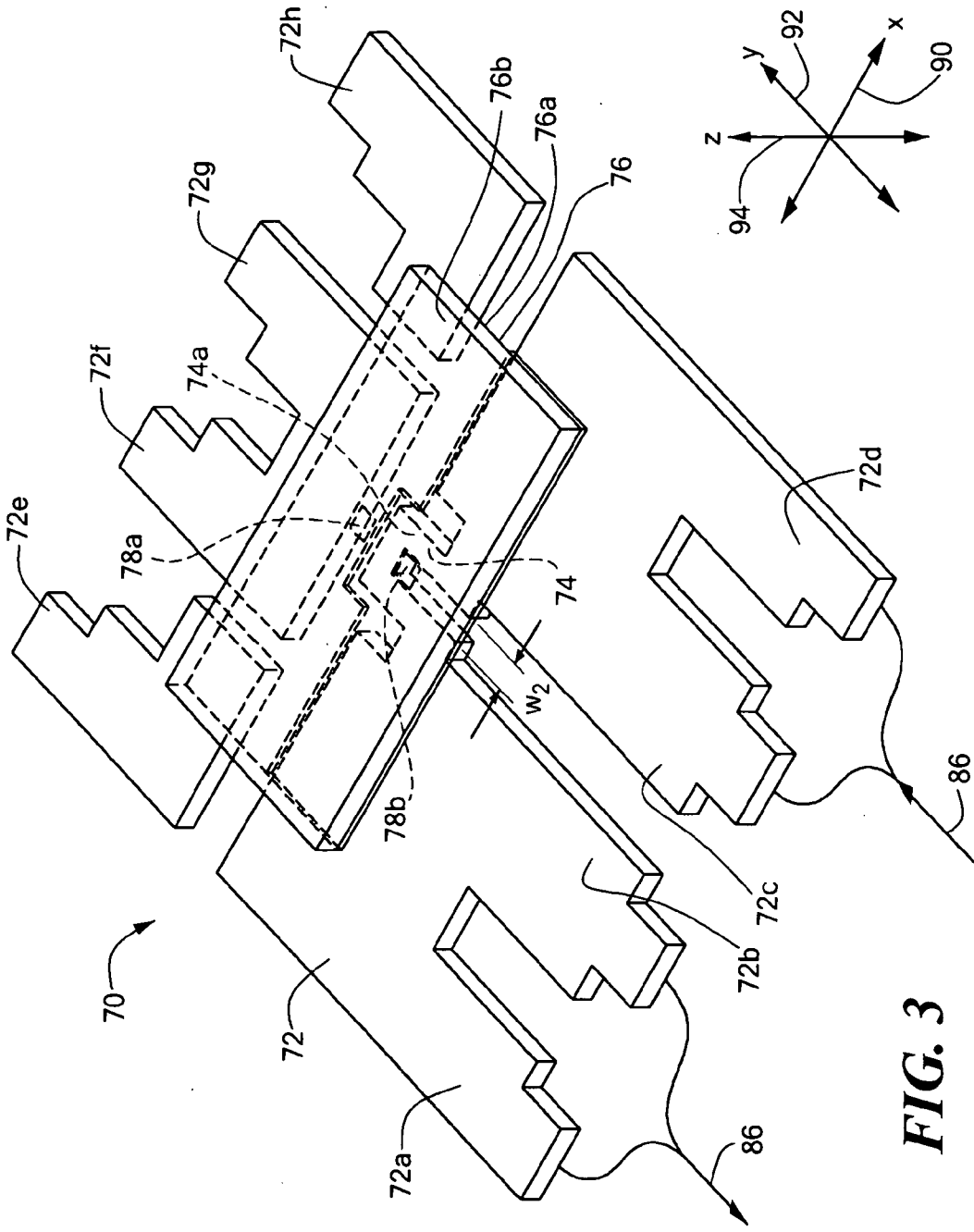


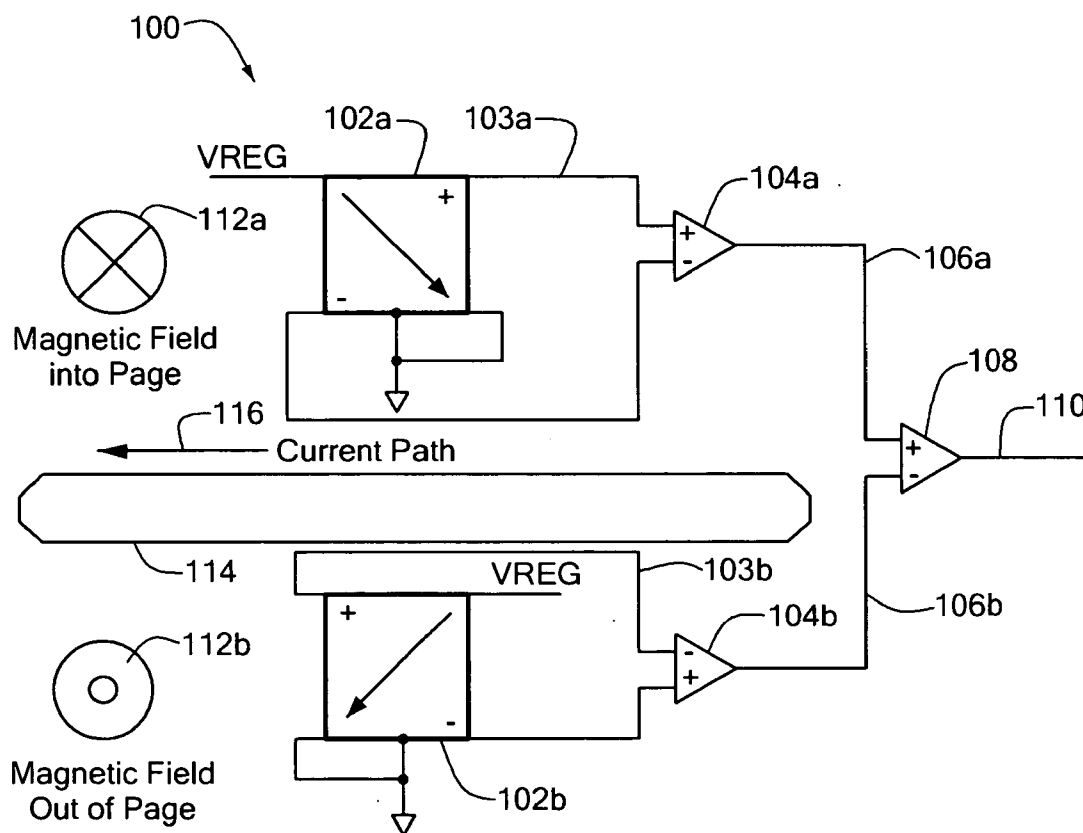
FIG. 1



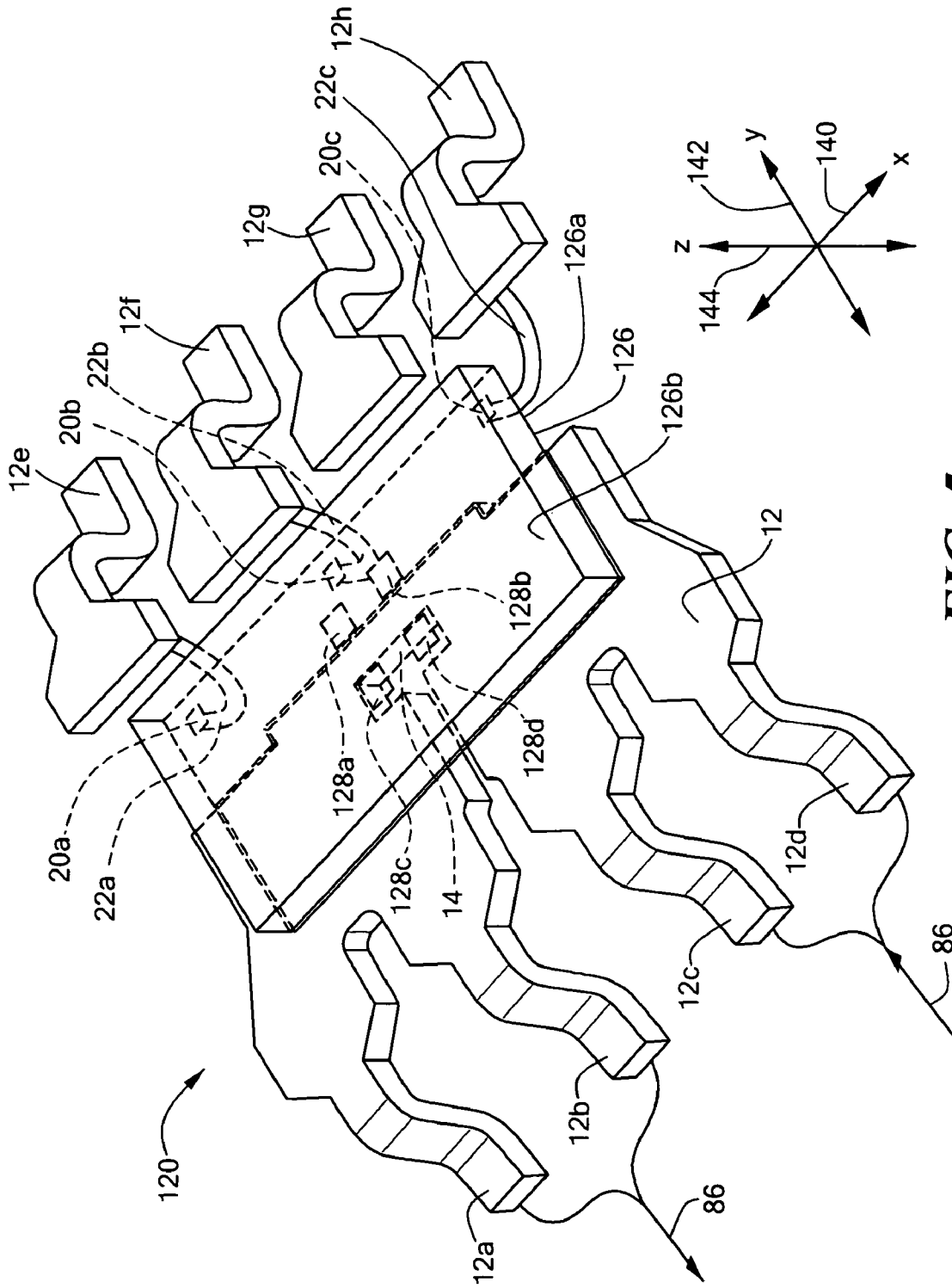
**FIG. 2**



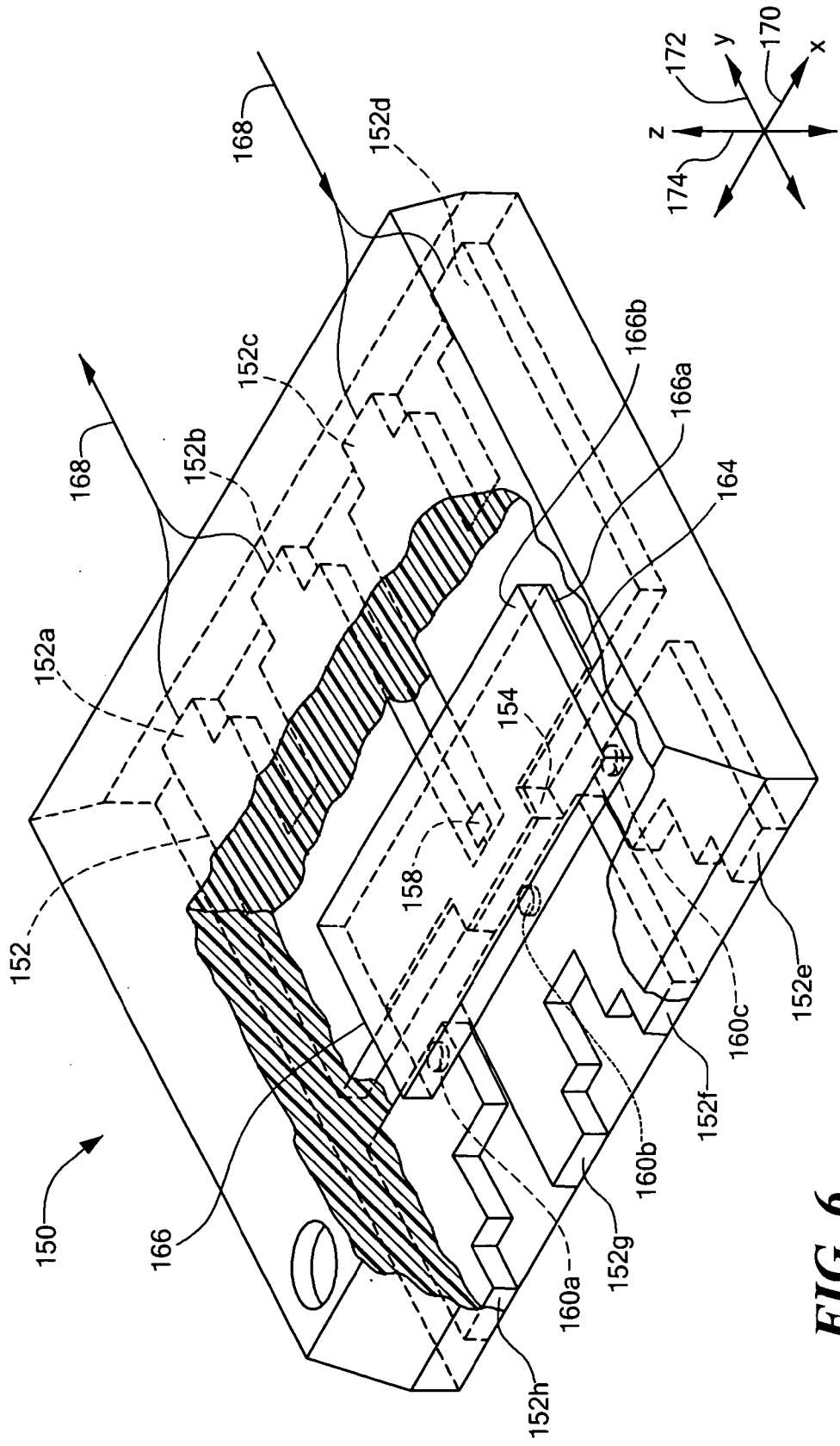
**FIG. 3**



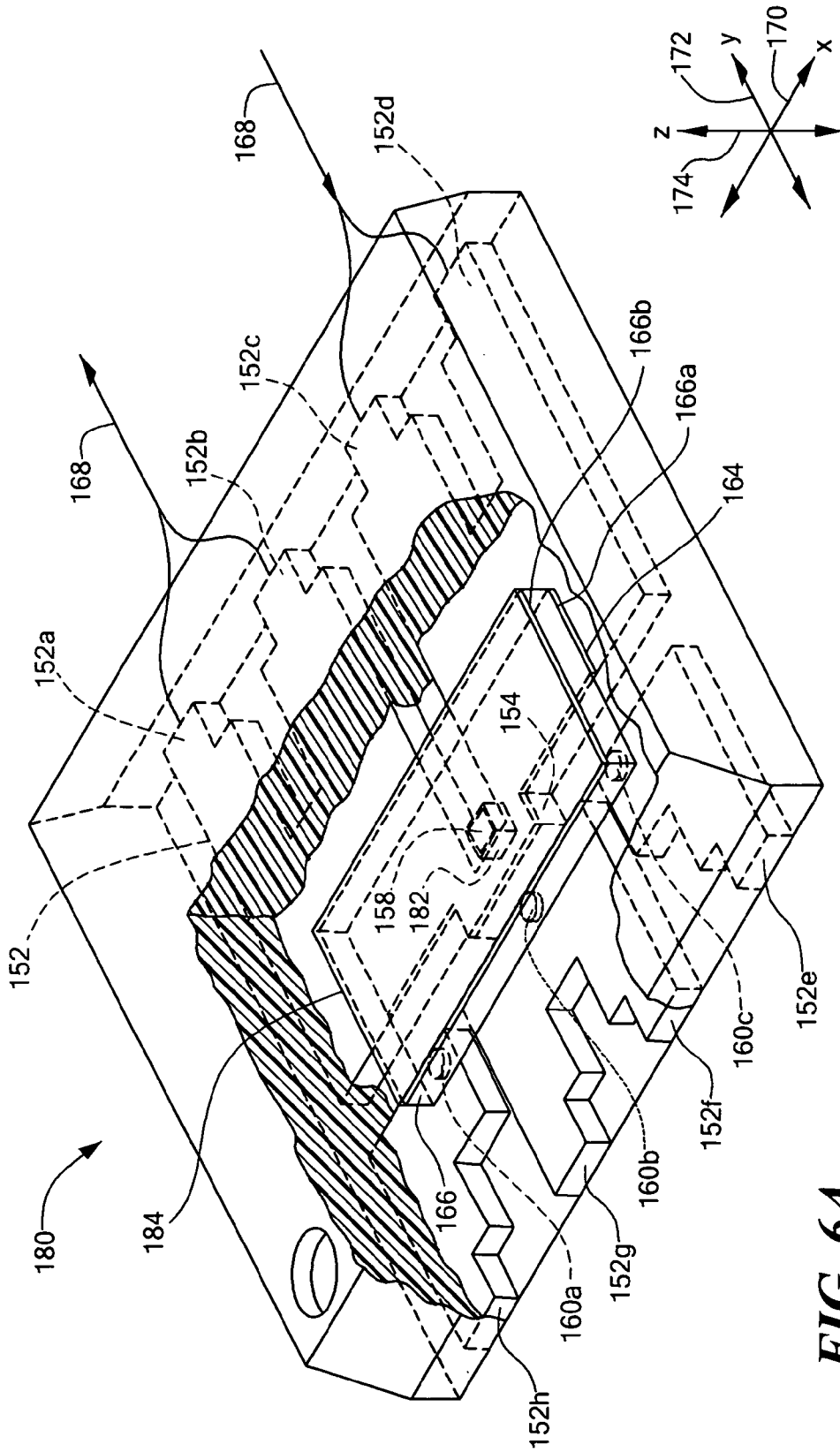
**FIG. 4**



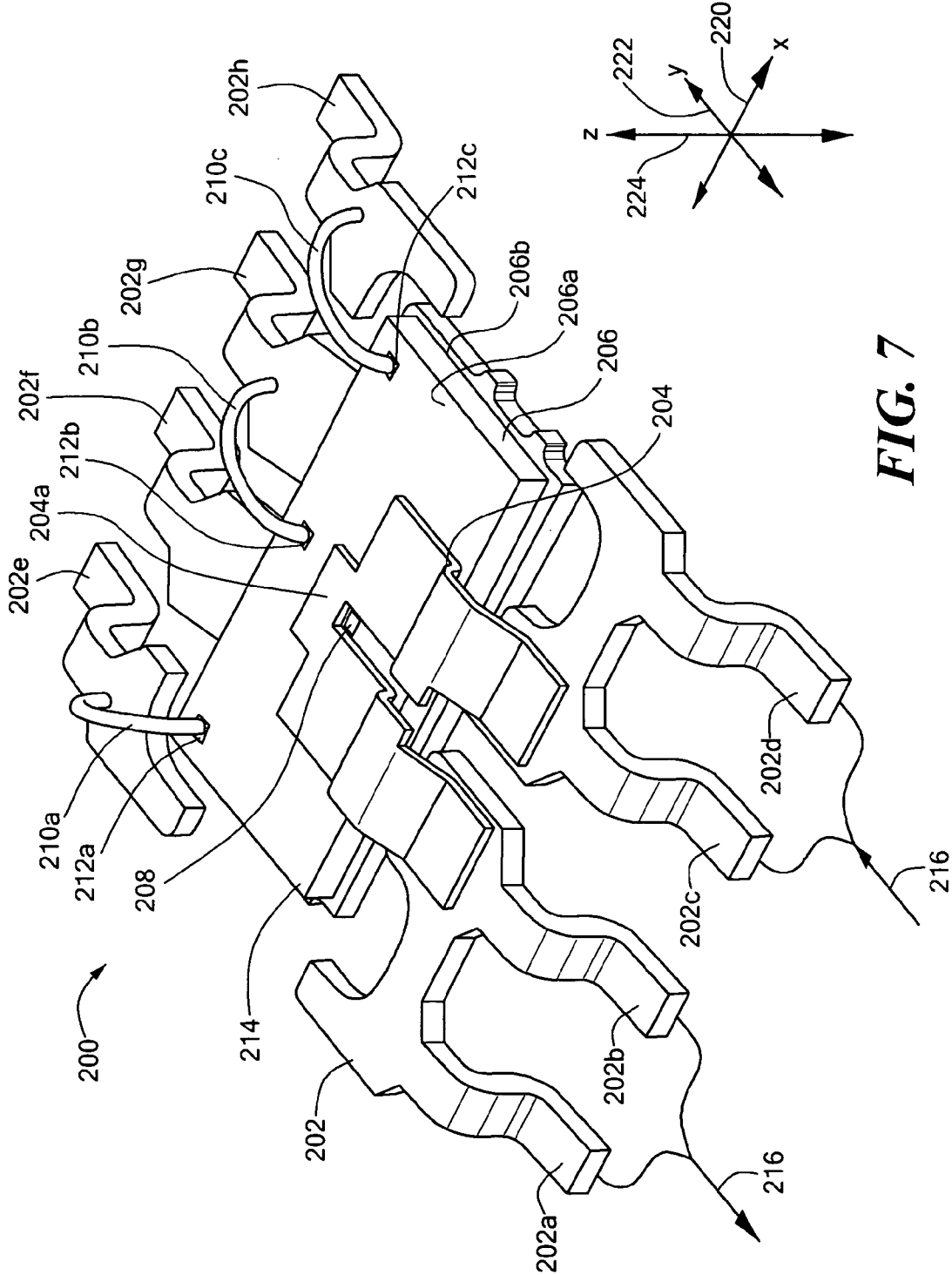
**FIG. 5**

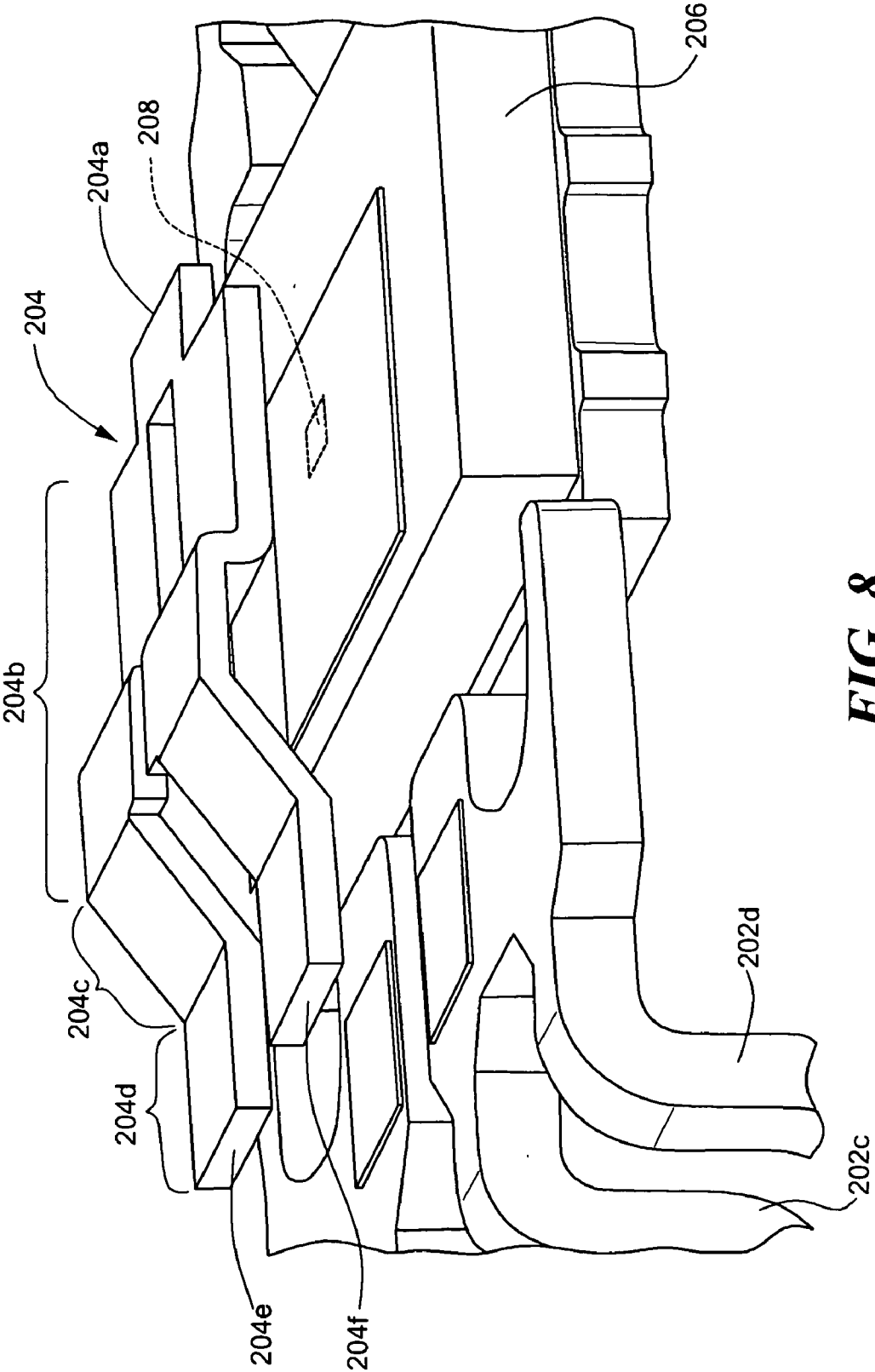


**FIG. 6**



**FIG. 6A**





**FIG. 8**

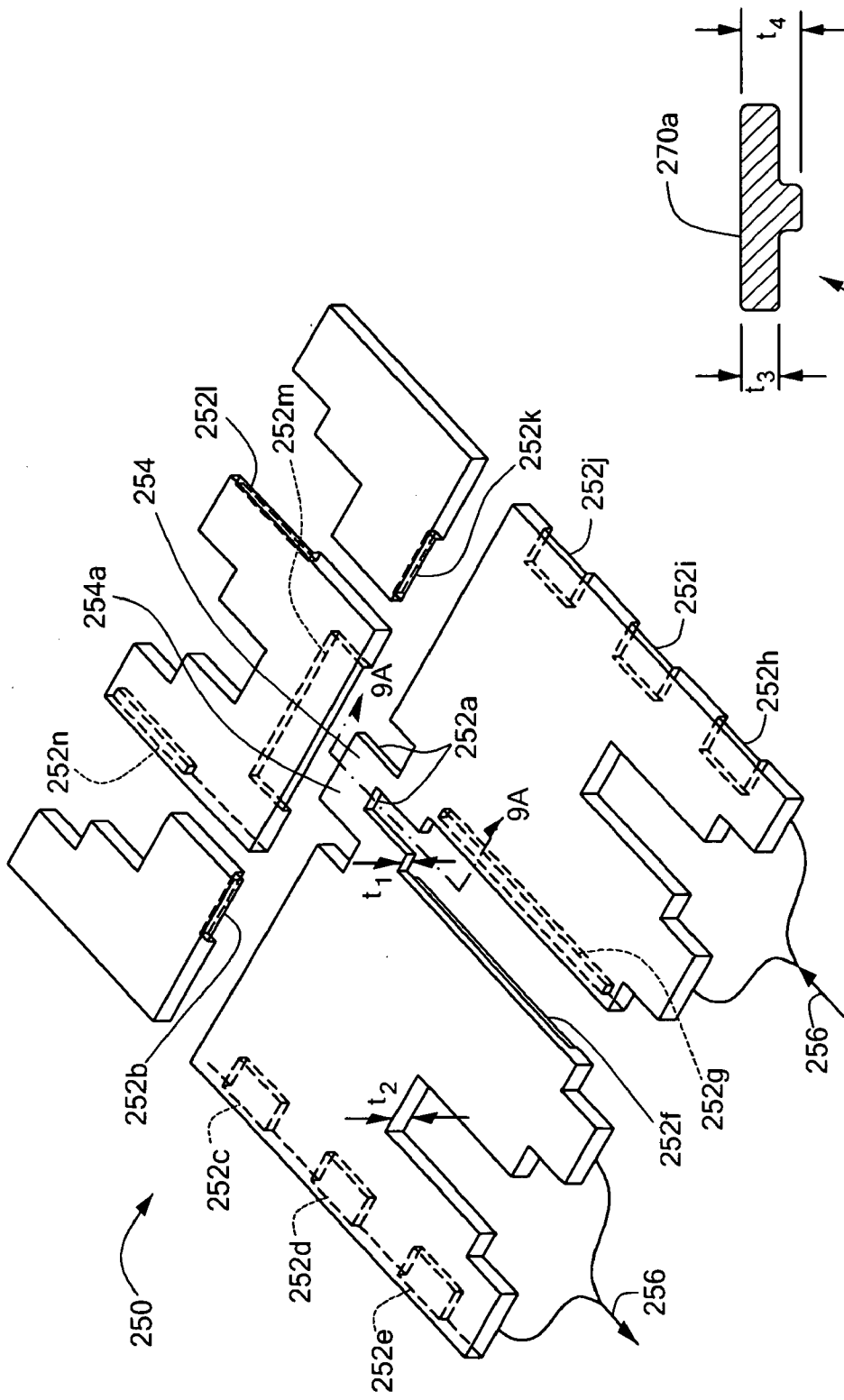


FIG. 9

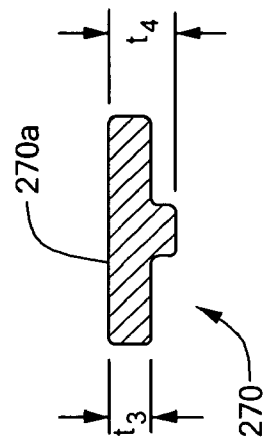
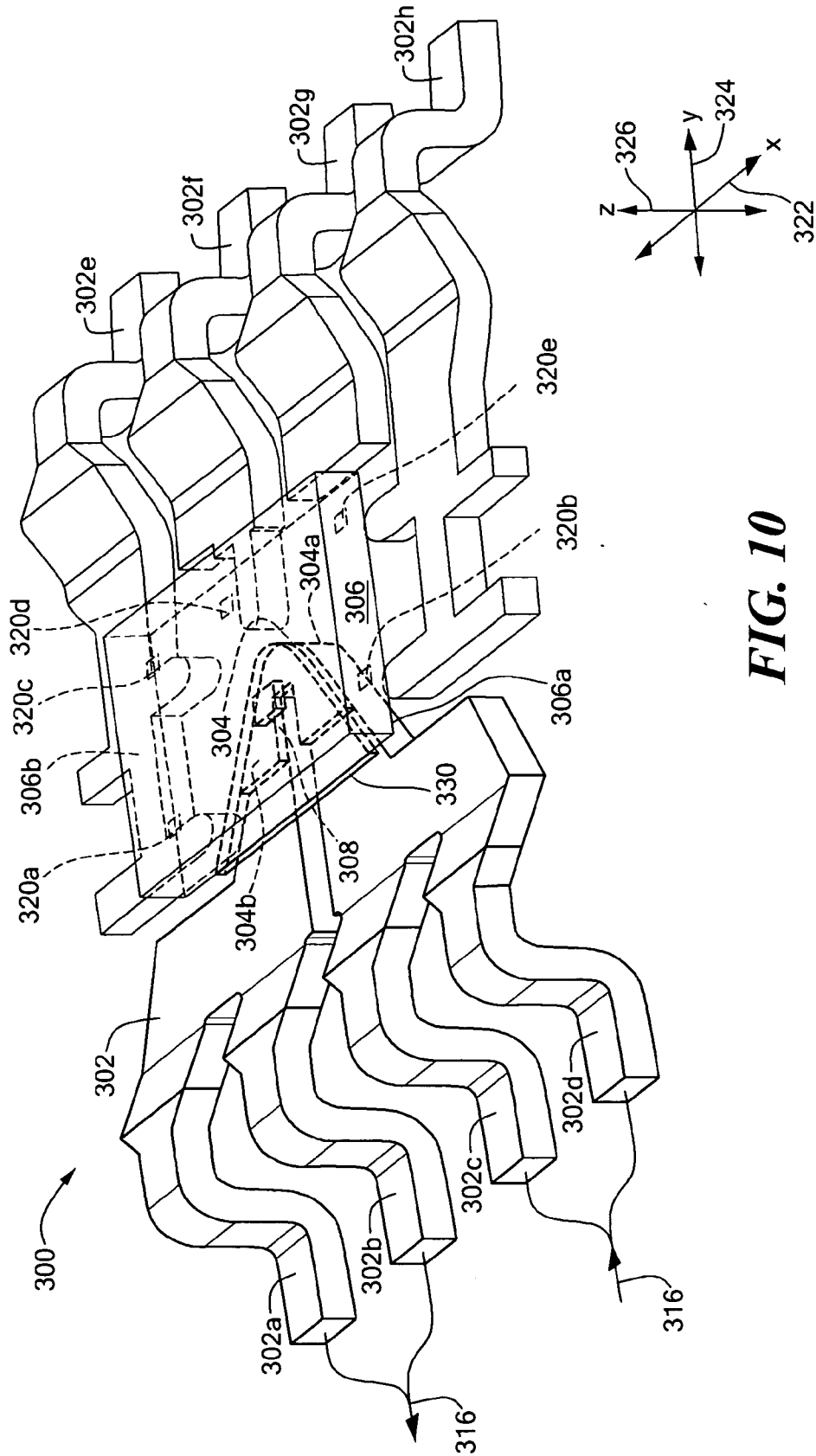
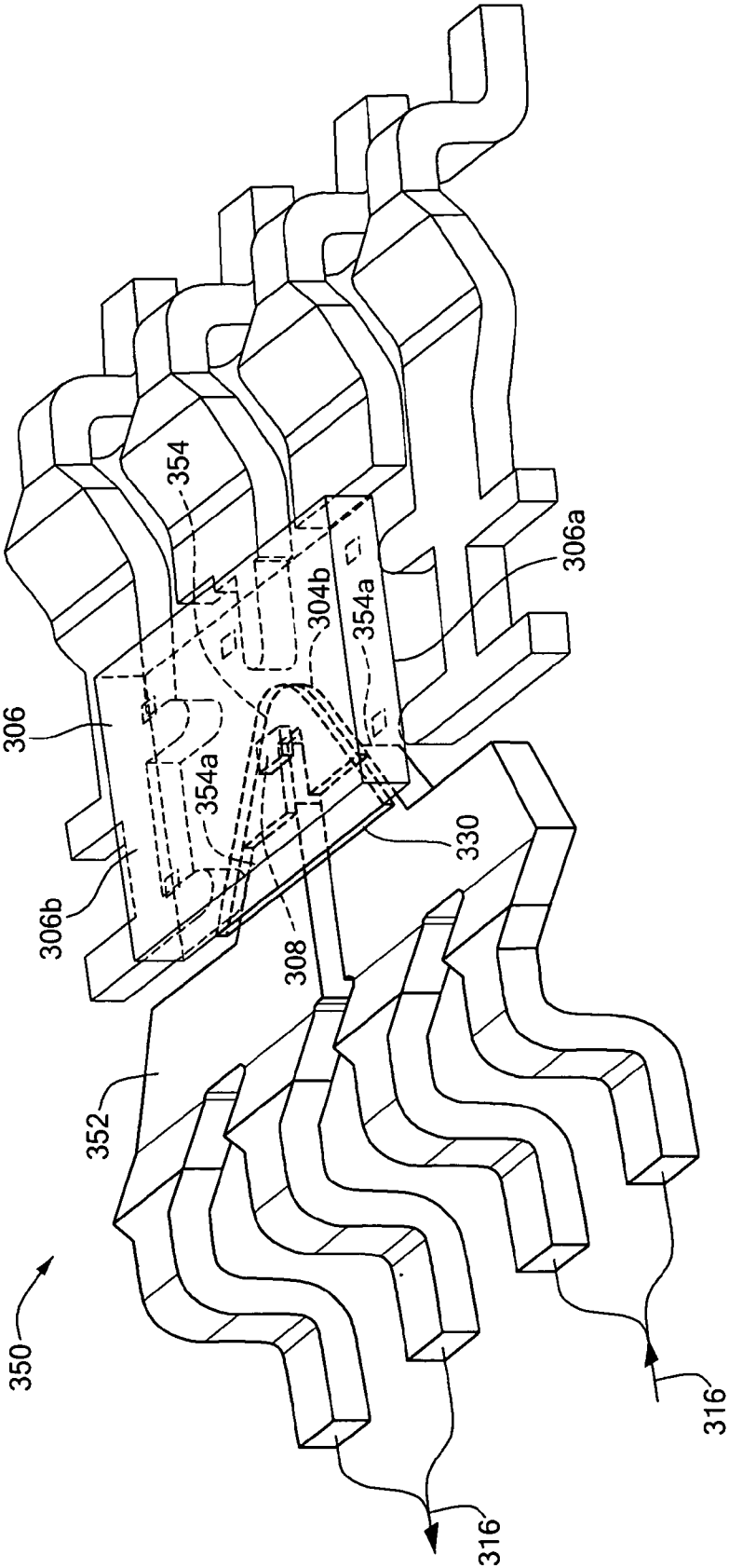


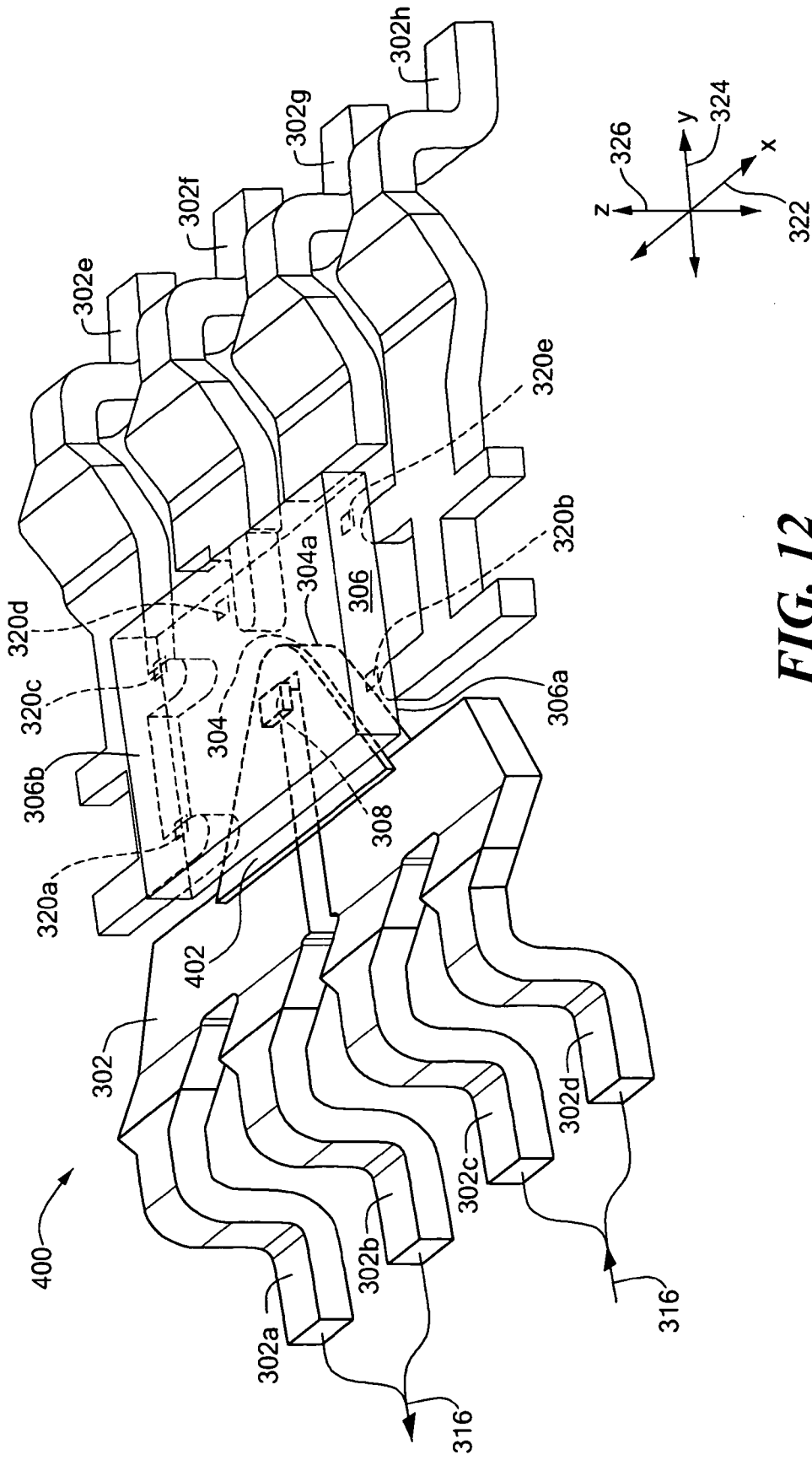
FIG. 9A



**FIG. 10**



**FIG. 11**



**FIG. 12**

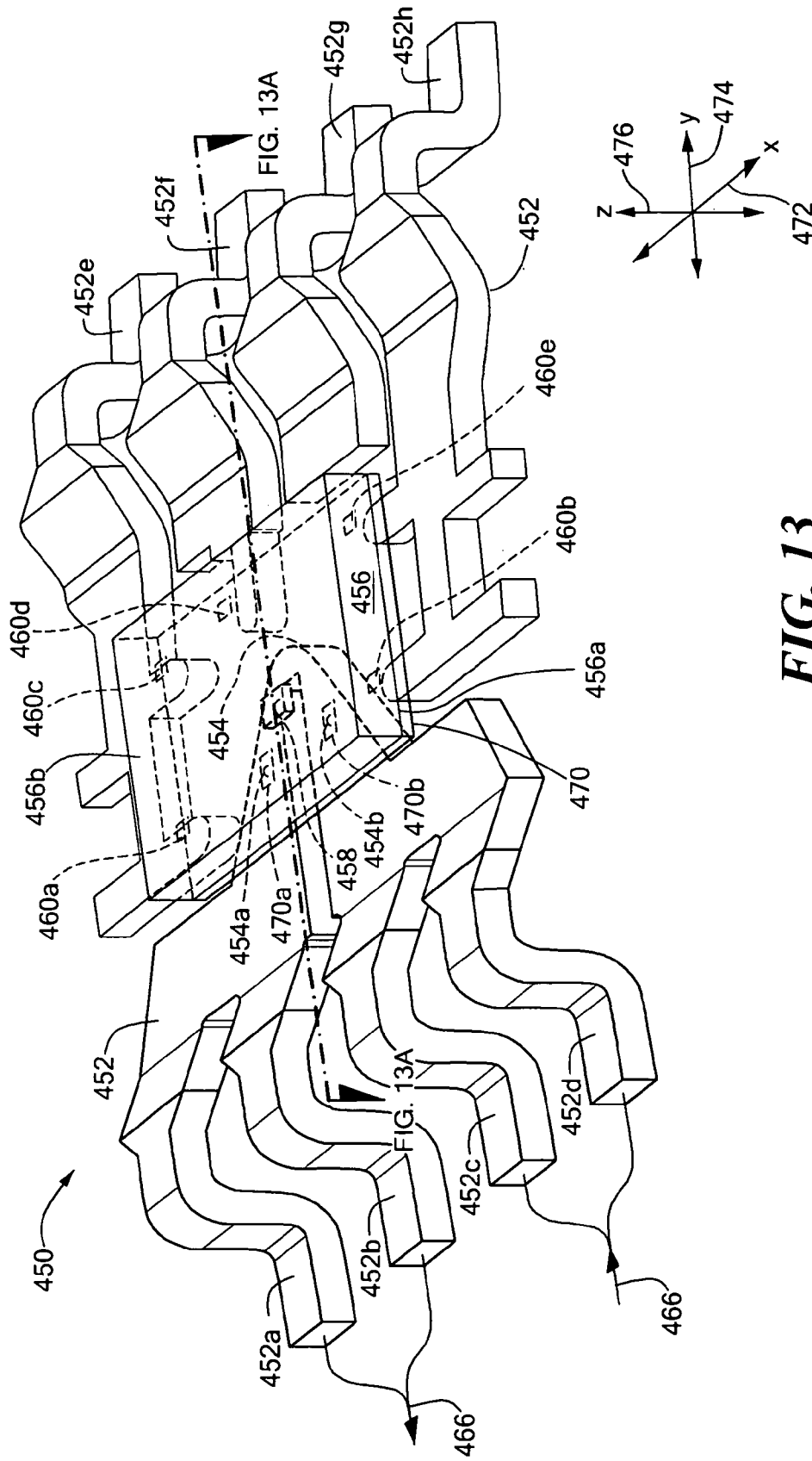
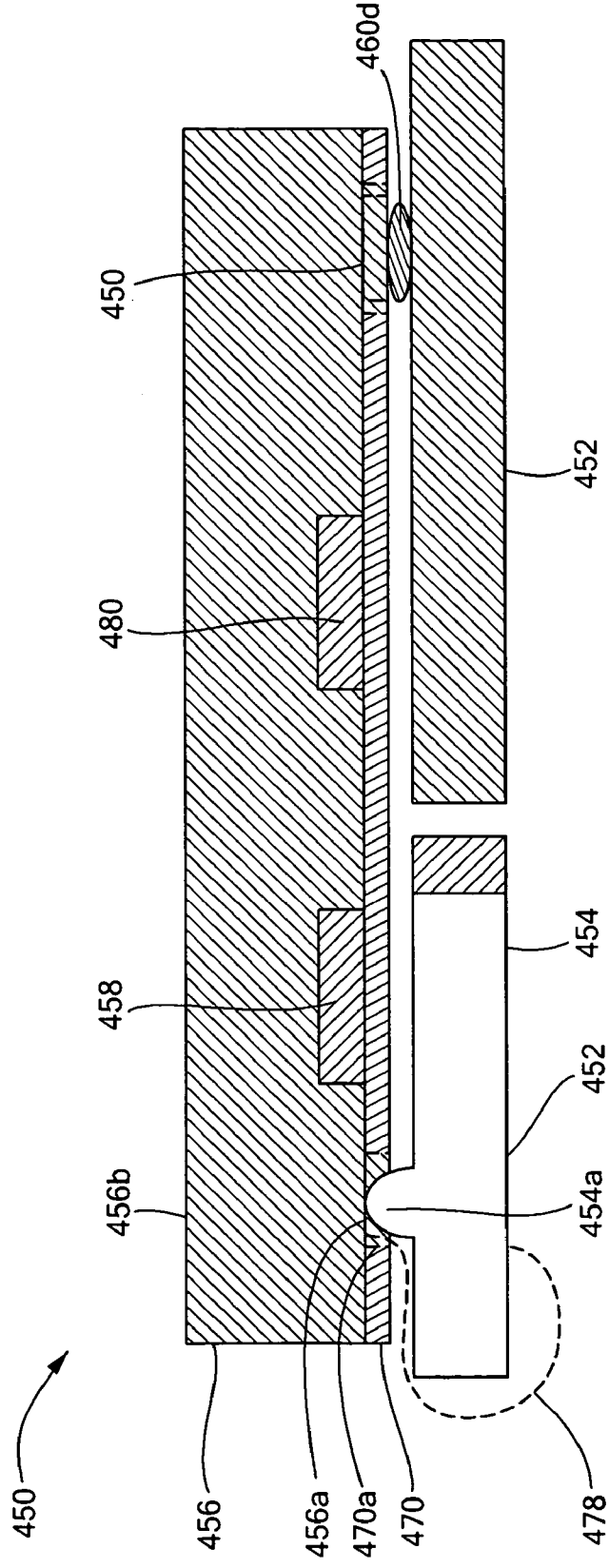


FIG. 13



**FIG. 13A**



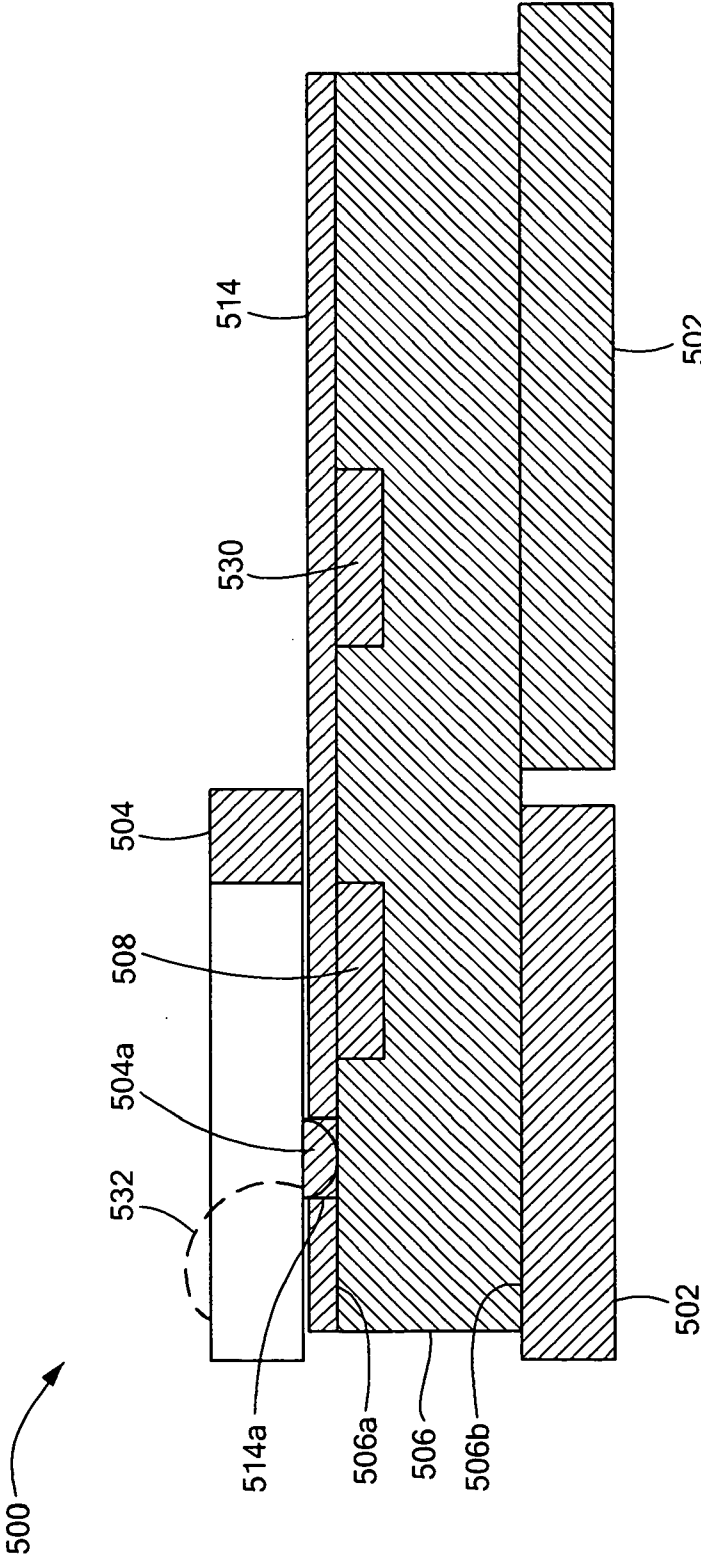


FIG. 14A

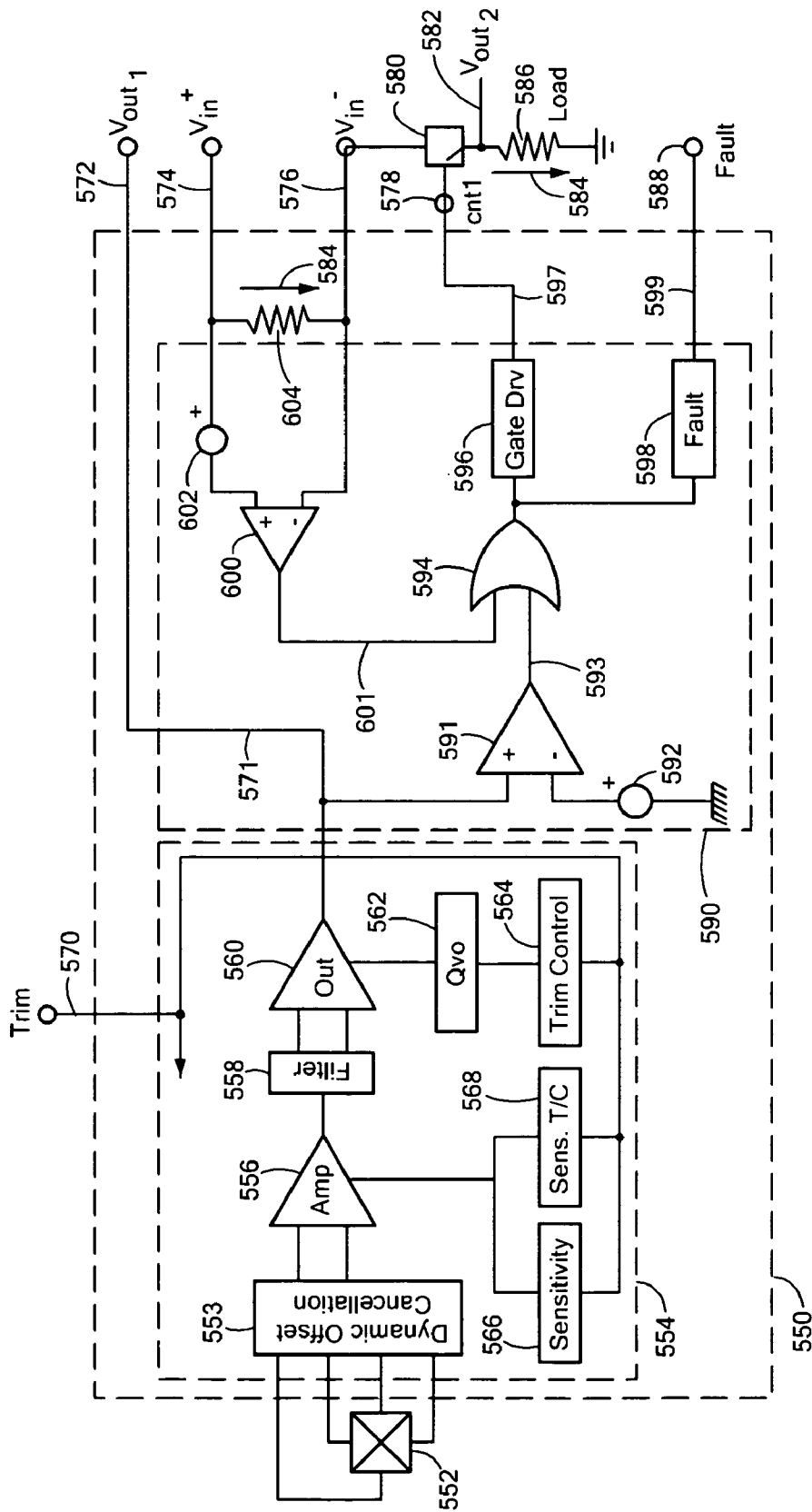
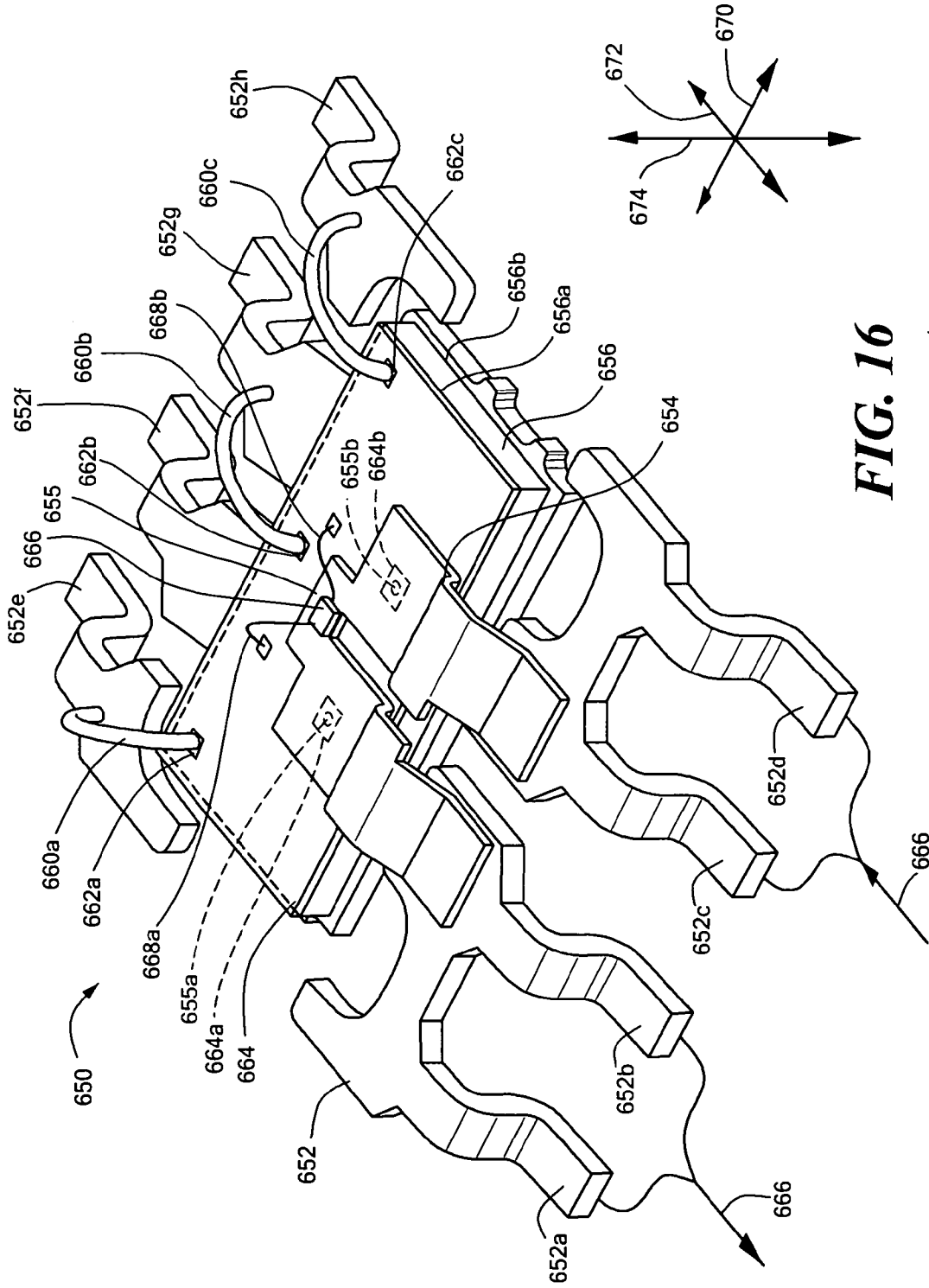


FIG. 15



**FIG. 16**

**CURRENT SENSOR**

**CROSS-REFERENCE TO RELATED APPLICATIONS**

[0001] This application is a Continuation-in-Part application of and claims the benefit under 35 U.S.C. §120 of U.S. application Ser. No. 11/144,970 filed on Jun. 3, 2005, which is a Continuation-in-Part application of and claims the benefit under 35 U.S.C. §120 of U.S. application Ser. No. 11/140,250 filed on May 27, 2005, which is a Continuation-in-Part application of and claims the benefit under 35 U.S.C. §120 of U.S. application Ser. No. 10/649,450 filed on Aug. 26, 2003, which applications are incorporated herein by reference in their entirety.

**STATEMENT REGARDING FEDERALLY SPONSORED RESEARCH**

[0002] Not Applicable.

**FIELD OF THE INVENTION**

[0003] This invention relates generally to electrical current sensors, and more particularly to a miniaturized current sensor in an integrated circuit package.

**BACKGROUND OF THE INVENTION**

[0004] As is known in the art, one type of conventional current sensor uses a magnetic field transducer (for example a Hall effect or magnetoresistive transducer) in proximity to a current conductor. The magnetic field transducer generates an output signal having a magnitude proportional to the magnetic field induced by a current that flows through the current conductor.

[0005] Some typical Hall effect current sensors include a gapped toroid magnetic flux concentrator, with the Hall effect element positioned in the toroid gap. The Hall effect device and toroid are assembled into a housing, which is mountable on a printed circuit board. In use, a separate current conductor, such as a wire, is passed through the center of the toroid. Such devices tend to be undesirably large, both in terms of height and circuit board area.

[0006] Other Hall effect current sensors include a Hall effect element mounted on a dielectric material, for example a circuit board. One such current sensor is described in a European Patent Application No. EP0867725. Still other Hall effect current sensors include a Hall effect element mounted on a substrate, for example a silicon substrate as described in a European Patent Application No. EP1111693.

[0007] Various parameters characterize the performance of current sensors, including sensitivity and linearity. Sensitivity is related to the magnitude of a change in output voltage from the Hall effect transducer in response to a sensed current. Linearity is related to the degree to which the output voltage from the Hall effect transducer varies in direct proportion to the sensed current.

[0008] The sensitivity of a current sensor is related to a variety of factors. One important factor is the flux concentration of the magnetic field generated in the vicinity of the current conductor and sensed by the Hall effect element. For this reason, some current sensors use a flux concentrator. Another important factor, in particular for a current sensor in

which a flux concentrator is not used, is the physical separation between the Hall effect element and the current conductor.

**SUMMARY OF THE INVENTION**

[0009] In accordance with the present invention, an integrated circuit includes a lead frame portion having a plurality of leads and a current conductor portion comprising at least two of the plurality of leads. The integrated circuit also includes a substrate having first and second opposing surfaces. The first surface is proximate to the current conductor portion and the second surface is distal from the current conductor portion. The integrated circuit also includes one or more magnetic field sensing elements disposed proximate to the current conductor portion. The integrated circuit also includes a current sensing circuit disposed on the first surface of the substrate and coupled to the one or more magnetic field sensing elements. The current sensing circuit is adapted to provide an output signal indicative of a current flowing through the current conductor portion. The integrated circuit also includes an overcurrent circuit disposed on the first surface of the substrate. The overcurrent circuit is adapted to sense a voltage drop associated with a current and further adapted to provide an output signal in response to the voltage drop. The output signal from the overcurrent circuit is indicative of the current sensed by the overcurrent circuit being above a predetermined current.

[0010] In accordance with another aspect of the present invention, a method of manufacturing an integrated circuit includes providing a lead frame portion having a plurality of leads comprising at least two leads forming a current conductor portion. The method also includes forming one or more magnetic field transducers disposed proximate to the current conductor portion. The method also includes mounting the substrate to the lead frame portion so that the first surface of the substrate is proximate to the current conductor portion and the second surface of the substrate is distal from the current conductor portion. The method also includes forming a current sensing circuit on the first surface of the substrate and coupled to the one or more magnetic field sensing elements. The current sensing circuit is adapted to provide an output signal indicative of a current flowing through the current conductor portion. The method also includes forming an overcurrent circuit on the first surface of the substrate and coupled to the current conductor portion. The overcurrent circuit is adapted to sense a voltage drop associated with a current and further adapted to provide an output signal in response to the voltage drop. The output signal is indicative of the current sensed by the overcurrent circuit being above a predetermined current.

**BRIEF DESCRIPTION OF THE DRAWINGS**

[0011] The foregoing features of the invention, as well as the invention itself may be more fully understood from the following detailed description of the drawings, in which:

[0012] **FIG. 1** is an isometric view of a current sensor in accordance with the present invention;

[0013] **FIG. 2** is a graph showing a relationship between position across a Hall effect element of the current sensor of **FIG. 1** and magnetic field;

[0014] **FIG. 3** is an isometric view of another embodiment of a current sensor in accordance with the present invention;

[0015] FIG. 4 is a schematic of a circuit forming part of the current sensor of FIG. 3;

[0016] FIG. 5 is an isometric view of yet another embodiment of a current sensor in accordance with the present invention;

[0017] FIG. 6 is an isometric view of still another embodiment of a current sensor in accordance with the present invention;

[0018] FIG. 6A is an isometric view of still another embodiment of a current sensor in accordance with the present invention;

[0019] FIG. 7 is an isometric view of still another embodiment of a current sensor in accordance with the present invention;

[0020] FIG. 8 is a further isometric view of the current sensor of FIG. 7;

[0021] FIG. 9 is an isometric view of an alternate lead frame having a thinner current conductor portion according to a further aspect of the invention;

[0022] FIG. 9A is a cross-sectional view of an alternate embodiment of the current conductor portion of FIG. 9;

[0023] FIG. 10 is an isometric view of still another embodiment of a current sensor in accordance with the present invention;

[0024] FIG. 11 is an isometric view of an alternate arrangement of the current sensor of FIG. 10;

[0025] FIG. 12 is an isometric view of another alternate arrangement of the current sensor of FIG. 10.

[0026] FIG. 13 is an isometric view of another alternate arrangement of the current sensor of FIG. 10;

[0027] FIG. 13A is a cross-sectional view of the current sensor of FIG. 13;

[0028] FIG. 14 is an isometric view of an alternate arrangement of the current sensor of FIGS. 7 and 8;

[0029] FIG. 14A is a cross-sectional view of the current sensor of FIG. 14;

[0030] FIG. 15 is a schematic drawing of an exemplary circuit that can be used in the current sensors of FIGS. 13, 13A, 14, and 14A, which includes a current sensing circuit and an overcurrent circuit; and

[0031] FIG. 16 is an isometric view of another alternate arrangement of the current sensor of FIGS. 7 and 8;

#### DETAILED DESCRIPTION OF THE INVENTION

[0032] Referring to FIG. 1, an exemplary current sensor 10 in accordance with the present invention includes a lead frame 12 having a plurality of leads 12a-12h. The leads 12a and 12b are coupled to the leads 12c and 12d to form a current path, or current conductor with a narrow portion 14 having a width w1. The current sensor 10 also includes a substrate 16 having a first surface 16a and a second, opposing surface 16b. The substrate 16 has a magnetic field transducer 18 which, in some embodiments, can be a Hall effect element 18, diffused into the first surface 16a, or otherwise disposed on the first surface 16a. The substrate 16

can be comprised of a semiconductor material, e.g., silicon, or, in an alternate embodiment, the substrate 16 can be comprised of an insulating material.

[0033] The substrate 16 is disposed above the lead frame 12 so that the first surface 16a is proximate to the current conductor portion 14 and the second surface 16b is distal from the current conductor portion 14 and more specifically, so that the Hall effect element 18 is in close proximity to the current conductor portion 14. In the illustrated embodiment, the substrate 16 has an orientation that is upside down (i.e., the first surface 16a is directed downward) relative to a conventional orientation with which a substrate is mounted in an integrated circuit package.

[0034] The substrate 16 has bonding pads 20a-20c on the first surface 16a, to which bond wires 22a-22c are coupled. The bond wires are further coupled to the leads 12e, 12f, 12g of the lead frame 12.

[0035] An insulator 24 separates the substrate 16 from the lead frame 12. The insulator 24 can be provided in a variety of ways. For example, in one embodiment, a first portion of the insulator 24 includes a four  $\mu\text{m}$  thick layer of a BCB resin material deposited directly on the first surface 16a of the substrate 16. A second portion of the insulator 24 may include a layer of underfill material, for example Staychip™ NUF-2071 E (Cookson Electronics Equipment, New Jersey), deposited on the lead frame 12. Such an arrangement provides more than one thousand volts of isolation between the substrate 16 and the lead frame 12.

[0036] It will be understood that the current conductor portion 14 is but a part of the total path through which an electrical current flows. For example, a current having a direction depicted by arrows 26 flows into the leads 12c, 12d, which are here shown to be electrically coupled in parallel, through the current conductor portion 14, and out of the leads 12a, 12b, which are also shown here to be electrically coupled in parallel.

[0037] With this arrangement, the Hall effect element 18 is disposed in close proximity to the current conductor portion 14 and at a predetermined position relative to the conductor portion 14, such that a magnetic field generated by an electrical current passing through the current conductor portion 14, in a direction shown by arrows 26, is in a direction substantially aligned with a maximum response axis of the Hall effect element 18. The Hall effect element 18 generates a voltage output proportional to the magnetic field and therefore proportional to the current flowing through the current conductor portion 14. The illustrated Hall effect element 18 has a maximum response axis substantially aligned with a z-axis 34. Because the magnetic field generated in response to the current is circular about the current conductor portion 14, the Hall effect element 18 is disposed just to the side (i.e., slightly offset along a y-axis 32) of the current conductor portion 14, as shown, where the magnetic field is pointed substantially along the z-axis 34. This position results in a greater voltage output from the Hall effect element 18, and therefore improved sensitivity. However, a Hall effect element, or another type of magnetic field sensor, for example a magnetoresistance element, having maximum response axis aligned in another direction, can be disposed at another position relative to the current conductor portion 14, for example, on top of the current conductor portion 14 (in a direction along z-axis 34).

[0038] While one Hall effect element **18** is shown on the first surface **16a** of the substrate **16**, it will be appreciated that more than one Hall effect element can be used, as shown in the embodiments of **FIGS. 3 and 5**. Also, additional circuitry, for example an amplifier, can also be diffused in or otherwise disposed on, or supported by the first and/or second surfaces **16a, 16b** of the substrate **16**. Exemplary circuitry of this type is shown in **FIG. 4**.

[0039] In the embodiment of **FIG. 1**, the close proximity between the Hall effect element **18** and the current conductor **14** is achieved by providing the Hall effect element **18** on the first substrate surface **16a**, which is positioned closer to the current conductor portion **14** than the second surface. In other embodiments, this advantageous close proximity is achieved by providing the Hall effect element **18** on the second substrate surface **16b** and forming the current conductor portion **14** so as to be in substantial alignment with the second surface **16b**, as shown in **FIGS. 7 and 8**.

[0040] Referring now to **FIG. 2**, a graph **50** illustrates the magnetic flux density in the direction of the z-axis **34** (**FIG. 1**) across the Hall element **18**, along an x-axis **30** (**FIG. 1**) and the y-axis **32** (**FIG. 1**) in the plane of the Hall effect element **18** (**FIG. 1**), for a current through current conductor portion **14** on the order of 10A. A center (not shown) of the Hall effect element **18** corresponds to three hundred microns on an abscissa **52**. A mantissa **54** corresponds to magnetic flux.

[0041] A magnetic flux curve **56** corresponds to the change in magnetic flux in the z-axis **34** relative to position along the x-axis **30**. Magnetic flux curve **58** corresponds to the change in magnetic flux in the z-axis **34** relative to position along the y-axis **32**.

[0042] The magnetic flux curves **56, 58** can be characterized as being substantially flat in the vicinity of the Hall element, which is centered at 300  $\mu\text{m}$ . Therefore, the output of the Hall effect element **18**, which is sensitive to magnetic fields in the direction of the z-axis **34**, is relatively insensitive to the position of the Hall effect element **18** along the x-axis **30** and along the y-axis **32**.

[0043] An illustrative Hall effect element **18** has dimensions along the x-axis **30** and along the y-axis **32** on the order of 200 microns and therefore the Hall effect element **18** lies in a region between 200 microns and 400 microns on the abscissa **52**. A change of position of the Hall effect element **18** by 50 microns either along the x-axis **30** or along the y-axis **32** results in little change in the magnetic field sensed by the Hall effect element. Therefore, the position of the Hall effect element in the x-axis **30** and the y-axis **32** can vary with manufacturing position tolerances without substantial effect upon the sensitivity of the current sensor **10** (**FIG. 1**).

[0044] The width **w1** (**FIG. 1**) of the current conductor portion **14** in the x-direction **30** relative to the dimension of the Hall effect element **18** in the x-direction **30** significantly affects the uniformity of the flux density in the z-direction **34** with position along the Hall effect element **18** in the x-direction **30**. In particular, the longer the current conductor portion **14** (i.e., the greater the width **w1**, **FIG. 1**), relative to the width of the Hall effect element **18** in the x-direction **30**, the longer the curve **56** remains substantially flat.

[0045] The width **w1** (**FIG. 1**) is selected in accordance with a variety of factors, including, but not limited to a

desired sensitivity of the current sensor **10** (**FIG. 1**), and a desired reduction of performance variation resulting from manufacturing variation in relative position of the current path **14** and the Hall effect element **18**. In general, it will be appreciated that selecting the width **w1** to be comparable to a width of the Hall effect element **18**, provides the greatest sensitivity of the current sensor **10**. However, it will also be appreciated that selecting the width **w1** to be greater than the width of the Hall effect element **18** provides the smallest performance variation resulting from manufacturing tolerance of Hall element positional placement in the x-direction **30**.

[0046] Referring now to **FIG. 3**, another exemplary current sensor **70** in accordance with the present invention includes a lead frame **72** having a plurality of leads **72a-72h** and a current conductor portion **74** having a width **w2**. The current sensor also includes a substrate **76** having a first surface **76a** and a second, opposing surface **76b**. The substrate **76** has first and second Hall effect elements **78a, 78b** diffused into the first surface **76a**, or otherwise disposed on or supported by the first surface **76a**. The substrate **76** is disposed on the lead frame **72** so that the Hall effect element **78** is in close proximity to the current conductor portion **74**. In the illustrated embodiment, the substrate **76** has an orientation that is upside down (i.e., the first surface **76a** is directed downward) in relation to the conventional orientation of a substrate mounted in an integrated circuit package. An insulator (not shown) can separate the substrate **76** from the lead frame **72**. The insulator can be the same as or similar to the insulator **24** shown in **FIG. 1**.

[0047] With this arrangement, both of the Hall effect elements **78a, 78b** are disposed in close proximity to the current conductor portion **74** and at predetermined positions relative to the current conductor portion **74** such that a magnetic field generated by an electrical current passing through the current conductor portion **74** in a direction shown by arrows **86**, is in a direction substantially aligned with a maximum response axis of the Hall effect elements **78a, 78b**. Here, the Hall effect elements **78a, 78b** each have a maximum response axis aligned with a z-axis **94**. Therefore, the Hall effect elements **78a, 78b** are disposed on opposite sides (i.e., slightly offset along a y-axis **92**) of the current conductor portion **74**, as shown, where the magnetic field is pointed along the z-axis **94**. In one embodiment, the Hall effect elements **78a, 78b** are offset (along the y-axis **92**) by substantially equal and opposite amounts about the current conductor portion **74**. However, Hall effect elements, or another type of magnetic field sensors, for example magnetoresistance elements, having maximum response axes aligned in another direction, can be disposed at other positions relative to the current conductor portion **74**, for example, on top (in a direction of the z-axis **94**) of the current conductor portion **74**.

[0048] In operation, current flows into the leads **72c, 72d**, which are coupled in parallel, through the current conductor portion **74**, and out of the leads **72a, 72b**, which are also coupled in parallel. The current flowing through the current conductor portion **74** generates a magnetic field which is sensed by the Hall effect elements **78a, 78b**. As described above, the Hall effect elements **78a, 78b** are in very close proximity to the current conductor portion **74** and at a predetermined position relative to the current conductor portion **74** for which the magnetic field generated by the

current is substantially aligned with the maximum response axis of the Hall effect elements **78a**, **78b**. This placement results in a greater voltage output from the Hall effect elements **78a**, **78b**, and therefore improved sensitivity.

[0049] It will be appreciated that the magnetic fields experienced by the first and the second Hall effect elements **78a**, **78b** are oriented in opposite directions, each aligned along the z-axis **94**. Therefore, if polarized in the same direction, the outputs of the two Hall effect elements **78a**, **78b** will be opposite in polarity. If the output from one of the Hall effect elements **78a**, **78b** is inverted, for example with an inverting amplifier, and then summed, i.e., differentially summed, with the output of the other of the Hall effect elements **78a**, **78b**, certain advantages are achieved.

[0050] As an initial advantage, the outputs of two Hall effect elements **78a**, **78b**, when differentially summed as described above, provide a voltage output of twice the magnitude of the voltage output from a single Hall effect element in the presence of the same current. Therefore, the current sensor **70** has twice the sensitivity of the current sensor **10** of **FIG. 1**.

[0051] As a second advantage, the current sensor **70** is relatively insensitive to variation in the position of the Hall effect elements **78a**, **78b** in the direction of the y-axis **92**. This is because, when moved in the direction of the y-axis **92**, the voltage output from one of the Hall effect elements **78a**, **78b** tends to increase while the voltage output from the other of the Hall effect elements **78a**, **78b** tends to decrease. Therefore, the differential sum of the two outputs remains relatively invariant.

[0052] While the lead frame **72** is shown to have the flat leads **72a-72h** suitable for surface mounting to a circuit board, it will be appreciated that a lead frame having bent leads, like the lead frame **12** of **FIG. 1**, can also be used. Also, while two Hall effect elements **78a**, **78b** are shown, more than two or fewer than two Hall effect elements can also be used.

[0053] Referring now to **FIG. 4**, a summing circuit **100** suitable for performing the differential signal summation described in conjunction with **FIG. 3** is shown coupled to two Hall effect elements **102a**, **102b**. The Hall effect elements **102a**, **102b** can be the same as or similar to the Hall effect elements **78a**, **78b** of **FIG. 3**. Here, each of the Hall effect elements **102a**, **102b** is rotated relative to the other Hall effect element by 90 degrees, as indicated by vectors on the Hall effect elements **102a**, **102b**. Therefore, in response to opposite magnetic fields **112a**, **112b** the Hall effect elements **102a**, **102b** generate output voltages **103a**, **103b** having the same polarities. The output voltage **103a** is coupled to amplifier **104a** arranged in a non-inverting configuration and the output voltage **103b** is coupled to the amplifier **104b** arranged in an inverting configuration. Therefore, the amplifier output voltages **106a**, **106b** move in opposite voltage directions in response to the magnetic fields **112a**, **112b**. The amplifier output voltages **106a**, **106b** are differentially coupled to an amplifier **108** to generate a differential summation, or a difference of the output voltages **106a**, **106b**. Therefore, the output voltages **106a**, **106b** differentially sum to provide a greater output voltage **110** at the output of amplifier **108**.

[0054] The summing circuit **100** can be used in the current sensor **70** of **FIG. 3**, in which case Hall effect elements

**102a**, **102b** correspond to the Hall effect elements **78a**, **78b**. In one particular embodiment, the summing circuit **100** is diffused into, or otherwise disposed upon, the first surface **76a** of the substrate **76**. In another embodiment, the summing circuit **100** is diffused into, or otherwise disposed upon, the second surface **76b** of the substrate **76**, while the Hall effect elements **78a**, **78b** remain on the first surface **76a**, coupled to the other circuit components through vias or the like.

[0055] Referring now to **FIG. 5**, in which like elements of **FIG. 1** are shown having like reference designations, another exemplary current sensor **120** includes a substrate **126** having a first surface **126a** and a second, opposing surface **126b**. Here, four Hall effect elements **128a-128d** are diffused into or otherwise disposed on the first surface **126a** of the substrate **126**. The substrate **126** is positioned relative to the lead frame **12** such that first and second Hall effect element **128a**, **128b** respectively are on one side of the current conductor portion **14** along a y-axis **142**, and third and fourth Hall effect elements **128c**, **128d** are on the opposite side of the current conductor portion **14** along the y-axis **42**, as shown. In one embodiment, the Hall effect elements **128a**, **128b** are offset (along the y-axis **142**) from the current conductor portion **14** by an amount equal to and opposite from the amount that the Hall effect elements **128c**, **128d** are offset (along the y-axis **142**) from the current conductor portion **14**.

[0056] With this arrangement, the Hall effect elements **128a-128d** are disposed in close proximity to the current conductor portion **14** and at predetermined positions relative to the conductor portion **14**, such that a magnetic field generated by an electrical current passing through the current conductor portion **14** in a direction shown by arrows **86**, is in a direction substantially aligned with a maximum response axis of the Hall effect elements **128a-128d**. Here, each of the Hall effect elements **128a-128d** has a maximum response axis aligned with a z-axis **144**. In the illustrated embodiment, the Hall effect elements **128a**, **128b** are disposed on an opposite side (i.e., slightly offset along a y-axis **142**) of the current conductor portion **144** than the Hall effect elements **128c**, **128d**, as shown, where the magnetic field is pointed along the z-axis **144**. However, Hall effect elements, or another type of magnetic field sensors, for example magnetoresistance elements, having maximum response axes aligned in another direction, can be disposed at other positions relative to the current conductor portion **14**, for example, on top (in a direction of the z-axis **144**) of the current conductor portion **14**. It will be appreciated that the first and second Hall effect elements **128a**, **128b** are exposed to a magnetic field in a direction along the z-axis **144** and the third and fourth Hall effect elements **128c**, **128d** are exposed to a magnetic field in the opposite direction along the z-axis **144**.

[0057] The four Hall effect elements **128a-128d** can be coupled to an electronic circuit arranged as a summing circuit, understood by one of ordinary skill in the art, in order to achieve certain advantages. The summing circuit, for example, can include two of the summing circuits **100** of **FIG. 4**. In one embodiment, the summing circuit can couple a first two of the Hall effect elements **128a-128d** with a first summing circuit, such as the summing circuit **100** of **FIG. 4**, and a second two of the Hall effect elements **128a-128d** with a second summing circuit, such as the summing circuit

**100.** With another amplifier, an output of the first summing circuit can be summed with an output of the second summing circuit. As an initial advantage, the four Hall effect elements **128a-128d**, coupled to a summing circuit as described, in the presence of the current, provide a voltage output four times the magnitude of a voltage output from a single Hall effect element, for example the Hall effect element **18** of **FIG. 1**, in the presence of the same current. Therefore, the current sensor **120** has four times the sensitivity of the current sensor **10** of **FIG. 1**.

[**0058**] As a second advantage, the current sensor **120** is relatively insensitive to variation in the position of the Hall effect elements **128a-128d** in the direction of the y-axis **142**. This is because, when moved in the direction of the y-axis **142**, the voltage output from two of the four Hall effect elements **128a-128d** tends to increase while the voltage output from the other two of the four Hall effect elements **128a-128d** tends to decrease. Therefore, when coupled as a summing circuit, the circuit output is relatively invariant to the y-axis position of the Hall effect elements.

[**0059**] Referring now to **FIG. 6**, an exemplary current sensor **150** in accordance with the present invention includes a lead frame **152** having a plurality of leads **152a-152h** and a current conductor portion **154**. The current sensor **150** also includes a substrate **166** having a first surface **166a** and a second, opposing surface **166b**. The substrate **166** has a Hall effect element **158** diffused into the first surface **166a**, or otherwise disposed on the first surface **166a**. The substrate **166** is disposed on the lead frame **152** so that the Hall effect element **158** is in close proximity to the current conductor portion **154**. The substrate **166** has an orientation that is upside down (i.e., the first surface **166a** is directed downward) in relation to the conventional orientation with which a substrate is mounted into an integrated circuit package. The substrate **166** is a flip-chip having solder balls **160a-160c** on the first surface **166a** of the substrate **166**. The solder balls **160a-160c** couple directly to the leads **152e-152h** as shown. An insulator **164** separates the substrate **166** from the lead frame **152**. The insulator **164** can be the same as or similar to the insulator **24** shown in **FIG. 1**.

[**0060**] With this arrangement, the Hall effect element **158** is disposed in close proximity to the current conductor portion **154** and at a predetermined position relative to the conductor portion **154**, such that a magnetic field generated by an electrical current passing through the current conductor portion **154** in a direction shown by arrows **168**, is in a direction substantially aligned with a maximum response axis of the Hall effect element **158**. The Hall effect element **158** has a maximum response axis aligned with a z-axis **174**. Therefore, the Hall effect element **158** is disposed just to the side (i.e., slight offset along a y-axis **172**) of the current conductor portion **14**, as shown, where the magnetic field is pointed along the z-axis **174**. However, a Hall effect element, or another type of magnetic field sensor, for example a magnetoresistance element, having a maximum response axis aligned in another direction, can be disposed at another position relative to the current conductor portion **154**, for example, on top (in a direction of the z-axis **174**) of the current conductor portion **154**.

[**0061**] Operation of the current sensor **150** is like the above-described operation of the current sensor **10** of **FIG. 1**. The Hall effect element **158**, being in close proximity to

the current conductor portion **154**, results in a greater output voltage from the Hall effect element **158**, and therefore an improved sensitivity.

[**0062**] While only one Hall effect element **158** is shown on the first surface **166a** of the substrate **166**, it will be appreciated that more than one Hall effect element can be used with this invention. Other circuitry, for example an amplifier, can also be diffused in or otherwise coupled to or supported by the first and/or second surfaces **166a**, **166b** of the substrate **166**.

[**0063**] While three solder balls **160a-160c** are shown, any number of solder balls can be provided, including dummy solder balls for stabilizing the substrate **166**. Also, while solder balls **160a-160c** are shown, other connection methods can also be used, including, but not limited to gold bumps, eutectic or high lead solder bumps, no-lead solder bumps, gold stud bumps, polymeric conductive bumps, anisotropic conductive paste, or conductive film.

[**0064**] Referring now to **FIG. 6A**, in which like elements of **FIG. 6** are shown having like reference designations, an exemplary current sensor **180** in accordance with the present invention includes a flux concentrator **182** and a flux concentrating layer **184**. The flux concentrator is located proximate the Hall effect sensor **158**, adjacent to and below the first surface **166a** of the substrate **166**. The flux concentrating layer **184** is disposed on (or adjacent to and above) the second surface **166b** of the substrate **166**.

[**0065**] In operation, the flux concentrator **182** and the flux concentrating layer **184** each tend to concentrate the magnetic flux generated by the current passing through the current conductor portion **154** so as to cause the current sensor **180** to have a higher sensitivity than the current sensor **150** of **FIG. 6**.

[**0066**] The flux concentrator **182** and the flux concentrating layer **184** can each be comprised of a variety of materials, including but not limited to, ferrite, Permalloy, and iron. An adhesion layer (not shown), for example, a titanium or chromium layer, may be present and would be understood by one skilled in the art.

[**0067**] While the flux concentrator **182** is shown having a cubic shape, in other embodiments, the flux concentrator can have another shape, for example, a polyhedral shape, an elliptical shape, or a spherical shape. While both the flux concentrator **182** and the flux concentrating layer **184** are shown, in other embodiments, only one of the flux concentrator **182** and the flux concentrating layer **184** can be provided. Also, while the flux concentrator **182** and the flux concentrating layer **184** are shown in conjunction with one magnetic field transducer **158**, it should be appreciated that the flux concentrator **182** and the flux concentrating layer **184** can also be applied to configurations having more than the one magnetic field transducer **158**, for example, the configurations shown in **FIGS. 1, 3, and 5**.

[**0068**] Referring now to **FIG. 7**, another exemplary current sensor **200** in accordance with the present invention includes a lead frame **202** having a plurality of leads **202a-202h**. The current sensor **200** also includes a substrate **206** having a first surface **206a** and a second, opposing surface **206b**. The substrate **206** has a Hall effect element **208** diffused into the first surface **206a**, or otherwise disposed on the first surface **206a**. A conductive clip **204** having

a current conductor portion **204a** is coupled to the leads **202a-202d**. Features of the conductive clip **204** are shown in **FIG. 8**. Suffice it to say here that the conductive clip is formed having a bend such that the conductive clip **204** passes up and over the first surface **206a** of the substrate **206**. The substrate **206** is disposed on the lead frame **202** so that the Hall effect element **208** is in close proximity to the current conductor portion **204a**. In the illustrated embodiment, the substrate **206** has a conventional mounting orientation with the first surface **206a** directed upward. The substrate **206** has bonding pads **212a-212c** on the first surface **206a**, to which bond wires **210a-210c** are coupled. The bond wires **210a-210c** are further coupled to the leads **202e, 202f, 202h**. An insulator **214** can be provided to isolate the substrate **206** from the conductive clip **204**. The insulator **214** can be the same as or similar to the insulator **24** shown in **FIG. 1**.

[0069] With this arrangement, the Hall effect element **208** is disposed in close proximity to the current conductor portion **204a**, which passes up and over the first surface **206a** of the substrate **206**. The Hall effect element **208** is disposed at a predetermined position relative to the conductor portion **204a** such that a magnetic field generated by an electrical current passing through the current conductor portion **204a** in a direction shown by arrows **216**, is in a direction substantially aligned with a maximum response axis of the Hall effect element **208**. The Hall effect element **208** has a maximum response axis aligned with a z-axis **224**. In the illustrated embodiment, the Hall effect element **208** is disposed just to the side (i.e., slight offset along a y-axis **222**) of the current conductor portion **204a**, as shown, where the magnetic field is pointed along the z-axis **224**. However, a Hall effect element, or another type of magnetic field sensor, for example a magnetoresistance element, having a maximum response axis aligned in another direction, can be disposed at another position relative to the current conductor portion **204a**, for example, essentially aligned above or below (in a direction of the z-axis **224**) with the current conductor portion **204a**.

[0070] In operation, current flows into the leads **202c, 202d**, which are coupled in parallel, through the conductive clip **204**, through the current conductor portion **204a**, and out of the leads **202a, 202b**, which are also coupled in parallel. The current flowing through the current conductor portion **204a** generates a magnetic field, which is sensed by the Hall effect element **208**. The Hall effect element **208** generates a voltage output proportional to the magnetic field and therefore proportional to the current flowing through the current conductor portion **204a**. As described above, the Hall effect element **208** is in very close proximity to the current conductor portion **204a** and at a predetermined position relative to the current conductor portion **204a** in which the magnetic field generated by the current is substantially aligned with the maximum response axis of the Hall effect element **208**. This position results in a greater voltage output from the Hall effect element **208**, and therefore improved sensitivity.

[0071] While only one Hall effect element **208** is shown on the second surface **206b** of the substrate **206**, it will be appreciated that more than one Hall effect element can be used. In particular, an embodiment having two Hall effect elements can be similar to the current sensor **70** of **FIG. 3** and an embodiment having four Hall effect elements can be

similar to the current sensor **120** of **FIG. 5**. Also, additional circuitry, for example an amplifier, can be diffused in or otherwise coupled to the first and/or second surfaces **206a, 206b** of the substrate **206**.

[0072] It should be appreciated that the conductive clip **204** can be formed in a variety of ways and from a variety of materials. In one particular embodiment, the conductive clip **204** is stamped, for example, from a copper-sheet. In another embodiment, the conductive clip **204** is formed from foil, for example copper foil. In yet another embodiment, the conductive clip **204** is formed by an etching process. The conductive clip **204** allows the use of the conventional mounting orientation of the substrate **206** while bringing the current conductor portion **204a** very close to the Hall effect element **208**.

[0073] The conductive clip **204** can be provided having a thickness selected in accordance with an amount of current that will pass through the conductive clip **204**. Therefore, if a current sensor adapted to sense relatively high currents is desired, the conductive clip can be relatively thick, whereas, if a current sensor adapted to sense relatively low currents is desired, the conductive clip **204** can be relatively thin. In another embodiment, if a current sensor adapted to sense relatively high currents is desired, more than one conductive clip **204** can be stacked in contact with other conductive clips to provide an increased effective thickness that is thicker than any one conductive clip **204**, and therefore, able to carry more current.

[0074] In the embodiment of **FIG. 7**, the close proximity between the Hall effect element **208** and the current conductor portion **204a** is achieved by providing the Hall effect element **208** on the first substrate surface **206a**, which is positioned closer to the current conductor portion **204a** than the second surface **206b**. In other embodiments, this advantageous close proximity is achieved by providing the Hall effect element **208** on the second substrate surface **206b** and forming the current conductor portion **204a** so as to be in substantial alignment with the second surface **206b**.

[0075] Referring now to **FIG. 8**, in which like elements of **FIG. 7** are shown having like reference designations, the conductive clip **204** is shown before it is coupled to the leads **202a-202d**. The conductive clip **204** includes the current conductor portion **204a**, a transition region **204b**, a bend region **204c**, and a bonding region **204d**. The bonding region **204d** includes two portions **204e, 204f** which couple to the leads **202a-202d**. The transition region **204b** can be elevated relative to the current conductor portion **204a** to avoid contact with the substrate **206**.

[0076] While Hall effect elements have been shown and described in association with embodiments of this invention, it will be recognized that other types of magnetic field sensors can be used. For example, magnetoresistance elements can be used in place of the Hall effect elements. However, a conventional magnetoresistance element has a maximum response axis that is perpendicular to the maximum response axis of a conventional Hall effect element. One of ordinary skill in the art will understand how to position one or more magnetoresistance elements relative to a current conductor portion in accordance with embodiments of the present invention to achieve the same results as the Hall effect element embodiments herein described.

[0077] Referring now to **FIG. 9**, a lead frame **250** is shown having a shape similar to the lead frame **72** of **FIG. 3** and

the lead frame 152 of FIG. 6. The lead frame 250 has a plurality of thinned portions 252a-252n that are thinner than other portions of the lead frame 250. The thinner portions can be provided by a variety of processes, including, but not limited to, chemical etching and stamping.

[0078] A current conductor portion 254 has a surface 254a and a thickness t1 which can be the same as or similar to the thickness of others of the thinned portion 252b-252n. Other portions of the lead frame have a thickness t2. In one particular embodiment, the thickness t1 of the current carrying portion 254 is the same as the thickness of the other thinned portions 252b-252n, and the thickness t1 is approximately half of the thickness t2. In one embodiment, the current conductor portion 254 has a cross section that is essentially rectangular, having the thickness t1.

[0079] It will be recognized that, in the presence of a current passing through the current conductor portion 254, the current conductor portion 254 being thinner, for example, than the current conductor portion 74 of FIG. 3, has a higher current density near the surface 254a than the current conductor portion 74 of FIG. 3 has near the surface 74a in the presence of a similar current. In other words, the current is compressed to be closer to the surface 254a than it would otherwise be with a thicker current conductor portion. As a result, a magnetic field generated by the current has a higher flux density in proximity to the surface 254a.

[0080] Therefore, when the lead frame 250 is used in place of the lead frame 72 of FIG. 3, the Hall effect elements 78a, 78b experience a greater magnetic field, resulting in a more sensitive current sensor.

[0081] Others of the thinned portion 252b-252n provide other advantages. For example, when the lead frame 250 is molded into a plastic surrounding body, the other thinned portions 252b-252n tend to lock the lead frame 250 more rigidly into the molded body.

[0082] The thickness t1 is selected in accordance with a variety of factors, including, but not limited to, a maximum current to be passed through the current conductor portion 254.

[0083] It will be understood that thinned portions can be applied to others of the lead frames shown above in embodiments other than the embodiment of FIG. 3 in order to achieve the same advantages.

[0084] Referring now to FIG. 9A, an alternate current conductor portion 270, suitable for replacing the current conductor portion 254 of FIG. 9, has a T-shaped cross section as would be seen from a cross-section taken along line 9A-9A of FIG. 9. The T-shape has a surface 270a, a first thickness t3, and a second thickness t4. The thickness t3 can be the same as or similar to the thickness t1 of FIG. 9, and the thickness t4 can be the same as or similar to the thickness t2 of FIG. 9. In one particular embodiment the thickness t3 is approximately half of the thickness t4.

[0085] For substantially the same reasons describe above in conjunction with FIG. 9, a magnetic field generated in response to a current passing through the current conductor portion 270 is higher in proximity to the surface 270a than it would be if the current conductor portion 270 had a uniform thickness t4.

[0086] While the current conductor portion 254 (FIG. 9) and the current conductor portion 270 have been described to have a rectangular cross section and a T-shaped cross section respectively, it should be appreciated that other cross-sectional shapes can be provided to achieve the above advantages.

[0087] Referring now to FIG. 10, another exemplary current sensor 300 in accordance with the present invention includes a lead frame 302 (also referred to herein as a lead frame portion) having a plurality of leads 302a-302h and a current conductor portion 304 provided as a combination of a first current conductor portion 304a and a second current conductor portion 304b. The current sensor 300 also includes a substrate 306 having a first surface 306a and a second, opposing, surface 306b. The substrate 306 has a Hall effect element 308 diffused into the first surface 306a, or otherwise disposed on or supported by the first surface 306a. The substrate 306 is disposed on the lead frame 302 so that the Hall effect element 308 is in close proximity to the current conductor portion 304. In the illustrated embodiment, the substrate 306 has an orientation that is upside down (i.e., the first surface 306a is directed downward) in relation to the conventional orientation of a substrate mounted in an integrated circuit package. The substrate 306 is a flip-chip having solder balls 320a-320e on the first surface 306a of the substrate 306. The solder balls 320a-320e couple directly to the leads 302e-302h. An insulating layer 330 can separate the substrate 306 from the lead frame 302. The insulating layer 330 can be the same as or similar to the insulator 24 shown in FIG. 1.

[0088] In one particular embodiment, the second current conductor portion 304b is deposited directly on the first surface 306a of the substrate 306 and no insulating layer 330 is used. The second current conductor portion 304b can be deposited by any conventional integrated circuit deposition technique, including, but not limited to, sputtering and electroplating. In other embodiments, the second current conductor portion 304b is a conductive structure separate from but proximate to the first surface 306a of the substrate 306, and the insulating layer 330 is disposed between the second current conductor portion 304b and the first surface 306a of the substrate 306.

[0089] It should be recognized that the Hall effect element 308, the insulating layer 330, the second current conductor portion 304b, and the first current conductor portion are under the substrate 306 as shown.

[0090] With these arrangements, the Hall effect element 308 is disposed in close proximity to the current conductor portion 304 and at a predetermined position relative to the current conductor portion 304 such that a magnetic field generated by an electrical current 316 passing through the current conductor portion 304 is in a direction substantially aligned with a maximum response axis of the Hall effect element 308. Here, the Hall effect element 308 has a maximum response axis aligned with a z-axis 326. Therefore, the Hall effect element 308 is disposed to a side (i.e., slightly offset along a y-axis 324) of the current conductor portion 304, as shown, where the magnetic field is pointed along the z-axis 326. However, a Hall effect element, or another type of magnetic field sensor, for example, a magnetoresistance element, having a maximum response axis aligned in another direction, can be disposed at another

position relative to the current conductor portion **304**, for example, on top (in a direction of the z-axis **326**) of the current conductor portion **304**.

[0091] The insulating layer **330** can be an interposing insulating layer or a substrate insulating layer associated with the substrate **306**. In some embodiments for which the insulating layer **330** is an interposing insulating layer, the insulating layer **330** is a ceramic interposing insulating layer.

[0092] In some embodiments for which the insulating layer **330** is a substrate insulating layer associated with the substrate **306**, the insulating layer **330** is a substrate taped insulating layer formed with a taping process. The substrate taped insulating layer can be comprised of a tape applied to the substrate, including but not limited to, a polymer tape, for example a Kapton® tape.

[0093] In still other embodiments for which the insulating layer **330** is a substrate insulating layer associated with the substrate **306**, the insulating layer **330** is a substrate deposited insulating layer formed with a deposition process. The deposition process used to form the insulating layer **330** can include a variety of processes, including, but not limited to, a screen printing process, a spin depositing process, a sputtering process, a plasma enhanced chemical vapor deposition (PECVD) process, and a low-pressure chemical vapor deposition (LPCVD) process. The screen printing process can result in a substrate insulating layer comprised of a variety materials, including but not limited to, polymer or ceramic materials. The spin depositing process can result in a substrate insulating layer comprised of a variety materials, including but not limited to a polymer, for example, polyimide (e.g., trade name Pyralin®) or bisbenzocyclobutene (BCB) (e.g., trade name Cyclotene®). The sputtering process can result in a substrate insulating layer comprised of a variety materials, including but not limited to, nitride or oxide. The PECVD process can result in a substrate insulating layer comprised of a variety materials, including but not limited to, nitride or oxide. The LPCVD process can result in a substrate insulating layer comprised of a variety materials, including but not limited to, nitride or oxide.

[0094] In still other embodiments for which the insulating layer **330** is a substrate insulating layer associated with the substrate **306**, the insulating layer **330** is a substrate oxide insulating layer formed with an oxide generation process. The substrate oxide insulating layer can be comprised, for example, of a silicon dioxide.

[0095] In operation, the current **316** flows into the leads **302c**, **302d**, which are coupled in parallel, through the current conductor portion **304**, and out of the leads **302a**, **302b**, which are also coupled in parallel. The current flowing through the current conductor portion **304** generates a magnetic field, which is sensed by the Hall effect element **308**. As described above, the Hall effect element **308** is in very close proximity to the current conductor portion **304** and at a predetermined position relative to the current conductor portion **304** at which the magnetic field generated by the current is substantially aligned with the maximum response axis of the Hall effect element **308**. This placement results in a greater voltage output from the Hall effect element **308**, and therefore greater sensitivity.

[0096] With this arrangement, it will be appreciated that the current **316** flowing through the current conductor por-

tion **304** splits between the first and second current conductor portions **304a**, **304b**, respectively.

[0097] While the lead frame **302** is shown to have the bent leads **302a-302h** suitable for surface mounting to a circuit board, it will be appreciated that a lead frame having leads with other shapes can also be used, including but not limited to, through hole leads having a straight shape.

[0098] While only one Hall effect element **308** is shown on the first surface **306a** of the substrate **306**, it will be appreciated that more than one Hall effect element can be used with this invention. Other circuitry, for example an amplifier, can also be diffused in or otherwise coupled to or supported by the first and/or second surfaces **306a**, **306b** of the substrate **306**.

[0099] While five solder balls **320a-320e** are shown, any number of solder balls can be provided, including dummy solder balls for stabilizing the substrate **306**. Also, while solder balls **320a-320e** are shown, other connection methods can also be used, including, but not limited to gold bumps, eutectic or high lead solder bumps, no-lead solder bumps, gold stud bumps, polymeric conductive bumps, anisotropic conductive paste, conductive film, or wire bonds.

[0100] While the substrate **306** is shown in a flip-chip arrangement, in other embodiments, the substrate **306** can be conventionally mounted such that the first surface **306a** is above the second surface **306b** when the integrated circuit **300** is mounted to an uppermost surface of a circuit board. With these arrangements, the first and second current conductor portions **304a**, **304b**, respectively, are each above the first surface **306a** of the substrate **306**.

[0101] Referring now to FIG. 11, in which like elements of FIG. 10 are shown having like reference designations, a current sensor **350** differs from the current sensor **300** of FIG. 10 by providing a current conductor portion **354** different than the current conductor portion **304** of FIG. 10. The current conductor portion **354** includes a first current conductor portion **354a** and the second current conductor portion **304b**. A lead frame **352** having the first current conductor portion **354a** does not form a continuous current path, unlike the lead frame **302** having the first current conductor portion **304a** of FIG. 10. With this arrangement, it will be appreciated that all of the current **316** flowing through the current conductor portion **354** passes through the second current conductor portions **304b**. Therefore, the current **316** passes closer to the Hall effect element **308** than in the current sensor **300** of FIG. 10, resulting in a higher sensitivity.

[0102] As described above in conjunction with FIG. 10, while the substrate **306** is shown in a flip-chip arrangement, in other embodiments, the substrate **306** can be conventionally mounted such that the first surface **306a** is above the second surface **306b** when the integrated circuit **300** is mounted to an uppermost surface of a circuit board. With these arrangements, the first and second current conductor portions **354a**, **304b**, respectively, are each above the first surface **306a** of the substrate **306**.

[0103] Referring now to FIG. 12, in which like elements of FIG. 10 are shown having like reference designations, a current sensor **400** differs from the current sensor **300** of FIG. 10 by providing a current conductor portion **304** having only the current conductor portion **304a** (i.e., there is

no current conductor portion **304b**, **FIG. 10**). The lead frame **302** having the first current conductor portion **304a** forms a continuous current path. With this arrangement, it will be appreciated that all of the current **316** passes through the current conductor portion **304a**.

[0104] An insulating layer **402** is disposed between the current conductor portion **304a** and the first surface **306a** of the substrate **306**. In some embodiments, the insulating layer **402** is an interposing insulating layer, for example a ceramic layer as described above in conjunction with **FIG. 10**. In other embodiments, the insulating layer **402** is a substrate insulating layer associated with the substrate. In other embodiments, the insulating layer **402** is a lead frame insulating layer associated with the lead frame **302**. It will be appreciated that, when associated with the lead frame, the insulating layer **402** can extend beyond the substrate **306** in a direction along the y-axis **324**. This arrangement provides enhanced reliability, since an edge of the substrate **306** is less likely to contact the lead frame **302**.

[0105] Interposing insulating layers and substrate insulating layers are described above, in conjunction with **FIG. 10**.

[0106] In some embodiments for which the insulating layer **402** is a lead frame insulating layer associated with the lead frame **302**, the insulating layer **402** is a lead frame taped insulating layer formed with a taping process. The lead frame taped insulating layer can be comprised of a tape applied to the lead frame, including but not limited to, a polymer tape, for example, a Kapton® tape.

[0107] In other embodiments for which the insulating layer **402** is a lead frame insulating layer associated with the lead frame **302**, the insulating layer **402** is a lead frame sprayed insulating layer formed with a spraying process. The lead frame sprayed insulating layer can be comprised of a variety of materials, including but not limited to a polymer, for example, a polyimide (e.g., trade name Pyralin®), a bisbenzocyclobutene (BCB) (e.g., trade name Cyclotene®) a sprayed dielectric, (e.g., trade names 3M Scotch® Insulating Spray 1601 and Loctite® ShadowCure® 3900), or a spray ceramic coating.

[0108] In other embodiments for which the insulating layer **402** is a lead frame insulating layer associated with the lead frame **302**, the insulating layer **402** is a lead frame deposited insulating layer formed with a deposition process. The lead frame deposited insulating layer can be formed with a variety of processes, including, but not limited to a screen printing process. The screen printing process can result in a lead frame deposited insulating layer comprised of a variety of materials, including but not limited to, polymers or ceramics. In still other embodiments, the lead frame deposited insulating layer is formed with a vacuum deposition process. For these embodiments, the lead frame deposited insulating layer can be comprised, for example, of a polymer, for example, parylene.

[0109] In still other embodiments for which the insulating layer **402** is a lead frame insulating layer associated with the lead frame **302**, the insulating layer **402** is a lead frame oxide insulating layer formed with an oxide generation process. The lead frame oxide insulating layer can be comprised, for example, of a sputtered oxide layer disposed onto the lead frame **302**.

[0110] Referring now to **FIG. 13**, another exemplary current sensor **450** includes a lead frame **452** (also referred

to herein as a lead frame portion) having a plurality of leads **452a-452h** and a current conductor portion **454**. The lead frame **452** can be similar to the lead frame **302** of **FIG. 12**. The current sensor **450** also includes a substrate **456** having a first surface **456a** and a second, opposing, surface **456b**. The substrate **456** has a Hall effect element **458** diffused into the first surface **456a**, or otherwise disposed on or supported by the first surface **456a**. The substrate **456** is disposed on the lead frame **452** so that the Hall effect element **458** is in close proximity to the current conductor portion **454**. In the illustrated embodiment, the substrate **456** has an orientation that is upside down (i.e., the first surface **456a** is directed downward) in relation to the conventional orientation of a substrate mounted in an integrated circuit package. The substrate **456** is arranged as a flip-chip having solder balls **460a-460e** on the first surface **456a** of the substrate **456**. The solder balls **460a-460e** couple directly to the leads **452e-452h**. An insulating layer **470** can separate the substrate **456** from the lead frame **452**. The insulating layer **470** can be the same as or similar to the insulator **24** shown in **FIG. 1**. The insulating layer **470** can cover a substantial portion of the surface **456a**. The insulating layer has regions **470a**, **470b**, which are devoid of insulating material, as will become more apparent from the discussion of **FIG. 13A** below.

[0111] The current conductor portion **454** has two features **454a**, **454b** (also referred to herein as bumps), which extend upward from the current conductor portion **454** in a direction of a z-axis **476**. The bumps **454a**, **454b** have a size and a shape selected to provide electrical contact between the current conductor portion **454** and the first surface **456a** of the substrate **456**. In particular, the two bumps **454a**, **454b** provide electrical contact to metalized features (not shown) upon the first surface **456a** of the substrate **456**, providing an electrical coupling to circuits (not shown) also disposed on the first surface **456a** of the substrate **456**. The electrical coupling and the circuits coupled thereto are discussed below in greater detail in conjunction with **FIG. 15**.

[0112] The lead frame **452** having the first current conductor portion **454** forms a continuous current path. With this arrangement, it will be appreciated that most of a current **466** passes through the current conductor portion **454**, while some small amount of the current **466** flows into the above-mentioned circuits on the substrate **456** via the bumps **454a** and **454b**. However, it will be recognized that the above-mentioned circuits can be designed to draw an insignificant amount of the current **466**. Therefore, nearly all of the current **466** passes through the current conductor portion **454**.

[0113] In some embodiments, the insulating layer **470** is an interposing insulating layer, for example a ceramic layer. In other embodiments, the insulating layer **470** is a substrate insulating layer associated with the substrate. In other embodiments, the insulating layer **470** is a lead frame insulating layer associated with the lead frame **452**.

[0114] Interposing insulating layers, substrate insulating layers, and lead frame insulating layers are described above in conjunction with **FIG. 10**.

[0115] It will become apparent from discussion below in conjunction with **FIGS. 13A and 15**, that the bumps **454a**, **454b** can provide a connection, which couples the current conductor portion **454** to circuitry adapted to detect an overcurrent condition, i.e., adapted to detect a current pass-

ing through the current conductor portion **452a**, which is greater than a predetermined current level or current threshold. To this end, the circuitry can detect a voltage difference between the first bump **454a** and the second bump **454b**, which is larger than a predetermined voltage drop or voltage threshold.

[0116] While only the one current conductor portion **454** is shown, it should be understood that a second current conductor portion can also be used. The second current conductor portion can be the same as or similar to the second current conductor portion **304b** of **FIG. 10**, and can be similarly disposed upon the first surface **456a** of the substrate **456** or upon the insulator **470**.

[0117] Referring now to **FIG. 13A**, in which like elements of **FIG. 13** are shown having like reference designations, the current conductor portion **454** includes the bump **454a**, which couples the current conductor portion **454** through the region **470a** of the insulating layer **470** to the first surface **456a** of the substrate **456**.

[0118] The Hall effect element **458** is disposed in or on the first surface **456a** of the substrate **456**. Other circuitry **480**, electrically coupled to the bump **454a**, can also be disposed in or on the first surface **456a** of the substrate **456**. Exemplary circuitry **480** is described below in conjunction with **FIG. 15**.

[0119] In other embodiments, a wire bond **478** or the like, here shown as a phantom line to indicate that it is an alternative arrangement to the bump **454a**, can be used to couple the current conductor portion **454** through the region **470a** of the insulating layer **470** to the first surface **456a** of the substrate **456**. It will be understood that a second wire bond (not shown) can be used in place of the other bump **454b** of **FIG. 13**. While the wire bond **478** appears to terminate to the substrate **456** directly above the current conductor portion **454**, it will be appreciated that the termination can be to the side of the current conductor portion **454**.

[0120] Referring now to **FIG. 14**, another exemplary current sensor **500** includes a lead frame **502** having a plurality of leads **502a-502h**. Only leads **502c** and **502d** shown for clarity, however, it will be understood that other ones of the leads **502a-502h** are arranged in a conventional lead arrangement. The current sensor **500** also includes a substrate **506** having a first surface **506a** and a second, opposing, surface **506b**. The substrate **506** has a Hall effect element **508** diffused into the first surface **506a**, or otherwise disposed on the first surface **506a**. A conductive clip **503** having a current conductor portion **504** is coupled to the leads **502a-502d**. The current conductor portion **504** includes two bumps **504a**, **504b**.

[0121] The conductive clip **503** is formed having a bend such that the conductive clip **503** passes up and over the first surface **506a** of the substrate **506**. The substrate **506** is disposed on the lead frame **502** so that the Hall effect element **508** is in close proximity to the current conductor portion **504**. In the illustrated embodiment, the substrate **506** has a conventional mounting orientation with the first surface **506a** directed upward. An insulator **514** (also referred to herein as an insulating layer) can insulate the substrate **506** from the conductive clip **503**. The insulator **514** has two regions **514a**, **514b** devoid of any insulating material. The insulator **514** can be similar to the insulator **24** shown in **FIG. 1**.

[0122] It will be understood that when the integrated circuit **500** is assembled, the bumps **504a**, **504b** align with and extend into the regions **514a**, **514b** of the insulating layer **514**, which are devoid of insulating material. The bumps **504a**, **504b** have a size and a shape selected to provide electrical contact between the current conductor portion **504** and the first surface **506a** of the substrate **506**. In particular, the two bumps **504a**, **504b** provide electrical contact to metalized features (not shown) upon the first surface **506a** of the substrate **506**, providing electrical coupling to circuits (not shown) also disposed on the first surface **506a** of the substrate **506**. The electrical coupling and the circuits coupled thereto are discussed below in greater detail in conjunction with **FIG. 15**.

[0123] While the conductive clip **503** having the current conductor portion **504**, which includes the bumps **504a**, **504b** is shown, it will be appreciated that, in other arrangements, other current conductor portions, for example, a straight current conductor portion, which includes two features or bumps can also be used.

[0124] While only the one current conductor portion **504** is shown, it should be understood that a second current conductor portion can also be used. The second current conductor portion can be the same as or similar to the second current conductor portion **304b** of **FIG. 10**, and can be similarly disposed upon the first surface **506a** of the substrate **506** or upon the insulator **514**.

[0125] Referring now to **FIG. 14A**, in which like elements of **FIG. 14** are shown having like reference designations, the current conductor portion **504** includes the bump **504a**, which couples the current conductor portion **504** through the region **514a** of the insulating layer **514** to the substrate **506**.

[0126] The Hall effect element **508** is disposed in or on the surface **506a** of the substrate **506**. Other circuitry **530**, electrically coupled to the bump **504a** can also be disposed in or on the surface **506a** of the substrate **506**. Exemplary circuitry **530** is described below in conjunction with **FIG. 15**.

[0127] In other embodiments, a wire bond **532** or the like, here shown as a phantom line to indicate that it is an alternative arrangement to the bump **504a**, can be used to couple the current conductor portion **504** through the region **514a** of the insulating layer **514** to the first surface **506a** of the substrate **506**. It will be understood that a second wire bond (not shown) can be used in place of the other bump **504b** of **FIG. 14**. While the wire bond **532** appears to terminate to the substrate **506** under the current conductor portion **506**, it will be appreciated that the termination can be to the side of the current conductor portion **506**.

[0128] Referring now to **FIG. 15**, exemplary circuitry **550** can be the same as or similar to the circuitry **480** used in the current sensor **450** of **FIG. 13A** or the circuitry **530** used in the current sensor **500** of **FIG. 14A**. The circuitry **550** can be coupled to a Hall effect element **552**. The Hall effect element **552** can be the same as or similar to the Hall effect element **458** of **FIGS. 13 and 13A**, or the Hall effect element **508** of **FIGS. 14 and 14A**.

[0129] The Hall effect element **552** is coupled to a current sensing circuit **554**, which includes a dynamic offset cancellation circuit **553**. The dynamic offset cancellation circuit

**553** provides a DC offset adjustment for DC voltage errors associated with the Hall effect element **552**.

[0130] The dynamic offset cancellation circuit **553** is coupled to an amplifier **556** that amplifies the offset adjusted Hall output signal. The amplifier **556** is coupled to a filter **558** that can be a low pass filter, a high pass filter, a band pass filter, and/or a notch filter. The filter **558** is selected in accordance with a variety of factors including, but not limited to, a desired response time, and a frequency spectrum of noise associated with the Hall effect element **552**, the dynamic offset cancellation circuit **553**, and the amplifier **556**. In one particular embodiment, the filter **558** is a low pass filter. The filter **558** is coupled to an output driver **560** that provides a current sensor output signal **571** at a node **572** for transmission to other electronics (not shown). As described more fully below, the current sensor output signal is indicative of a magnitude of a current passing through a conductor.

[0131] A trim control circuit **564** is coupled to node **570**. The node **570** can receive a trim signal that permits various current sensor parameters to be trimmed, typically during manufacture. To this end, the trim control circuit **564** includes one or more counters enabled by an appropriate signal applied to the node **570**.

[0132] The trim control circuit **564** is coupled to a quiescent output voltage (Qvo) circuit **562**. The quiescent output voltage is the voltage of the output signal **571** when the current sensed by the Hall effect element **552** is zero. Nominally, for a unipolar supply voltage, Qvo is equal to  $V_{cc}/2$ . Qvo can be trimmed by applying a suitable trim signal through the node **570** to a first trim control circuit counter within the trim control circuit **564**, which, in turn, controls a digital-to-analog converter (DAC) within the Qvo circuit **562**.

[0133] The trim control circuit **564** is further coupled to a sensitivity adjustment circuit **566**. The sensitivity adjustment circuit **566** permits adjustment of the gain of the amplifier **556** in order to adjust the sensitivity of the current sensor **550**. The sensitivity can be trimmed by applying a suitable trim signal through the node **570** to a second trim control circuit counter within the trim control circuit **564**, which, in turn, controls a DAC within the sensitivity adjustment circuit **566**.

[0134] The trim control circuit **564** is further coupled to a sensitivity temperature compensation circuit **568**. The sensitivity temperature compensation circuit **568** permits adjustment of the gain of the amplifier **556** in order to compensate for gain variations due to temperature. The sensitivity temperature compensation circuit **568** can be trimmed by applying a suitable trim signal through the node **570** to a third trim control circuit counter within the trim control circuit **564**, which, in turn, controls a DAC within the sensitivity temperature compensation circuit **568**.

[0135] The Hall effect element **552** is placed in proximity to a current conductor portion **604**, here shown to be apart from the Hall effect element **552** for clarity. The current conductor portion **604** can be the same as or similar to the current conductor portion **454** of FIGS. 13 and 13A and the current conductor portion **504** of FIGS. 14 and 14A, formed by a coupling of integrated circuit leads. In operation, a current **584** enters a node **574** of the current sensor **550**,

passes through the current conductor portion **604** and out a node **576**, where it passes through a switch **580** and through a load **586**, both of which can be external to the integrated circuit **550**. The switch **580** can be, for example, a relay or a field effect transistor (FET).

[0136] It would be desirable to stop the current **584** upon detection of an overcurrent condition, for example a short circuit, which would otherwise result in an undesirably high current **584**, which could damage the integrated circuit **550** or other associated circuitry. To this end, an overcurrent circuit **590** can detect the overcurrent condition.

[0137] The overcurrent circuit **590** includes a comparator **591** coupled to receive the current sensor output signal **571** and also coupled to a voltage reference **592**. An output **593** of the comparator **591** is coupled to a logic gate **594**. The logic gate **594** is coupled to a gate driver, which generates a control signal **597** at a node **578** of the circuitry **550**. The node **578** is coupled to a control node of the switch **580** and is operable to open the switch **580**, stopping the current **584**, in response to detection of the overcurrent condition by the Hall effect element **552**.

[0138] The logic gate **594** is also coupled to a fault circuit **598**, which generates a fault output signal **599** at a node **588** of the integrated circuit **550**. The fault output signal **599** is indicative of the overcurrent condition, i.e., the current **584** being above a predetermined current.

[0139] It will be recognized that the amplifier **591** and the voltage reference **592** are responsive to the current sensor output signal **571**, which is responsive to signals generated by the Hall effect element **552**. It will be appreciated that the Hall effect element **552** has a relatively slow response time. Therefore, if the switch **580** were controlled only in the fashion described above in response to signals generated by the Hall effect element **552**, some rapid overcurrent conditions might damage the integrated circuit **550** or the load **586** before the switch **580** could be opened. Circuitry described below can provide a faster response time to the overcurrent condition.

[0140] A comparator **600** and a voltage reference **602** are coupled to the current conductor portion **604** of the integrated circuit **550**. As described above, the current conductor portion **604** can be the same as or similar to the current conductor portion **454** of FIGS. 13 and 13A and the current conductor portion **504** of FIGS. 14 and 14A, formed by a coupling of integrated circuit leads. The coupling from the current conductor portion **604** to the voltage reference **602** and to the comparator **600** can be provided in a variety of ways, including but not limited to, the bumps **454a** and **454b** of FIGS. 13 and 13A and the bumps **504a**, **504b** of FIGS. 14 and 14A.

[0141] In operation, since the current conductor portion **604** has an associated resistance, a voltage appears across the current conductor portion **604** in response to the current **584**. When the current **584** is sufficiently large, an output signal **601** of the comparator **600** changes state, causing the control signal **597** to change state, opening the switch **580** and stopping the current. Opening the switch **580** in this manner occurs more rapidly than if the switch **580** were to be opened only by the comparator **591** in response to signals generated by the Hall effect element **552**.

[0142] It will be appreciated by those of ordinary skill in the art that the circuitry **550** shown in FIG. 15 is illustrative

of exemplary circuitry that may be associated with and integrated into a current sensor, like the current sensor **450** of **FIGS. 13 and 13A** and the current sensor **500** of **FIGS. 14 and 14A**.

[0143] It will also be appreciated that, in other embodiments, the switch **580** can be integrated into the current sensor circuitry **550**.

[0144] Referring now to **FIG. 16**, another exemplary current sensor **650** is like the current sensor of **500** of **FIG. 14**, however, the current sensor **650** includes a second substrate **655** described more fully below. The current sensor **650** includes a lead frame **652** having a plurality of leads **552a-552h**. The current sensor **650** also includes a substrate **656** having a first surface **656a** and a second, opposing, surface **656b**. A conductive clip **654** having a current conductor portion **655** is coupled to the leads **652a-652d**. The current conductor portion **605** includes two bumps **655a**, **655b**. A second substrate **666**, having a magnetic field sensing element disposed thereon, for example, a magneto-resistance element (not shown), can be disposed upon the current conductor portion **655**. The magnetic field sensing element on the second substrate **666** can be coupled to the first surface **656a** of the substrate **656** with wire bonds **668a**, **668b** or the like.

[0145] The conductive clip **654** is formed having a bend such that the conductive clip **654** passes up and over the first surface **656a** of the substrate **656**. In the illustrated embodiment, the substrate **656** has a conventional mounting orientation with the first surface **656a** directed upward. An insulator **664** (also referred to herein as an insulating layer) can insulate the substrate **656** from the conductive clip **654**. The insulator **664** has two regions **664a**, **664b** devoid of any insulating material. The insulator **664** can be similar to the insulator **24** shown in **FIG. 1**.

[0146] Shown in assembled form, the bumps **655a**, **655b** align with and extend into the regions **664a**, **664b** of the insulating layer **664**, which are devoid of insulating material. The bumps **655a**, **655b** have a size and a shape selected to provide electrical contact between the current conductor portion **655** and the first surface **656a** of the substrate **656**. In particular, the two bumps **655a**, **655b** provide electrical contact to metalized features (not shown) upon the first surface **656a** of the substrate **656**, providing electrical coupling to circuits (not shown) also disposed on the first surface **656a** of the substrate **656**. The electrical coupling and the circuits coupled thereto are discussed above in greater detail in conjunction with **FIG. 15**.

[0147] While the conductive clip **654** having the current conductor portion **655**, which includes the bumps **655a**, **655b** is shown, it will be appreciated that, in other arrangements, other current conductor portions, for example, a straight current conductor portion, which includes two features or bumps can also be used.

[0148] While only the one current conductor portion **655** is shown, it should be understood that a second current conductor portion can also be used. The second current conductor portion can be the same as or similar to the second current conductor portion **304b** of **FIG. 10**, and can be similarly disposed upon the first surface **656a** of the substrate **656** or upon the insulator **664**.

[0149] The current sensor **650** has two substrate **656**, **666**. The current sensor **650** shows but one arrangement that can

provide two substrates, while also providing a current carrying conductor, e.g., **655**, in close proximity to a magnetic field sensing element, and/or while including an overcurrent circuit as described above in conjunction with **FIG. 15**. Other two substrate arrangements are described in U.S. patent application Ser. No. \_\_\_\_\_, entitled "Arrangements for an Integrated Sensor," having attorney docket number ALLEG-162PUS, having inventors Michael C. Doogue, Vijay Mangtani, and William P. Taylor, filed on Jan. 20, 2006, which application is incorporated by reference herein in its entirety. Any of the arrangements described therein can be combined with a current carry conductor and/or with an overcurrent circuit.

[0150] The current sensor **450** of **FIGS. 13 and 13A**, the current sensor **500** of **FIGS. 14 and 14A**, the current sensor **550** of **FIG. 15**, and the current sensor **650** of **FIG. 16**, and are shown having couplings between current conductor portions **454**, **504**, **604**, and **655**, respectively, and associated overcurrent circuitry, which is represented by the circuitry **590** of **FIG. 15**. However, in other embodiments, other current sensors similar to the current sensors **450**, **500**, **550**, and **650** have no couplings between the current conductor portions **454**, **504**, **604**, and **655** and associated overcurrent circuitry, i.e., no bumps or wire bonds. In other words, referring to the current sensor **550** of **FIG. 15**, the current conductor portion **604** of **FIG. 15** does not couple to the nodes **574** or **576** of **FIG. 15**. In these embodiments, the overcurrent circuitry **590** (**FIG. 15**), remains coupled to the nodes **574** and **576**, and the nodes **574** and **576** couple to another circuit element apart from the current sensor **550**. For example, in some arrangements, the nodes **574**, **576** can couple to a circuit trace on a circuit board which carries the same current as that which passes through the current conductor portion **604** (**FIG. 15**). With these arrangements, the overcurrent circuit **590** is able to sense a voltage drop resulting from current passing through the circuit trace, providing essentially the same effect, wherein the overcurrent circuit **590** provides similar functions to those described above.

[0151] Having described preferred embodiments of the invention, it will now become apparent to one of ordinary skill in the art that other embodiments incorporating their concepts may be used. It is felt therefore that these embodiments should not be limited to disclosed embodiments, but rather should be limited only by the spirit and scope of the appended claims. All references cited herein are hereby incorporated herein by reference in their entirety.

What is claimed is:

1. An integrated circuit, comprising:
  - a lead frame portion having a plurality of leads;
  - a current conductor portion comprising at least two of the plurality of leads;
  - a substrate having first and second opposing surfaces, the first surface proximate to the current conductor portion and the second surface distal from the current conductor portion;
  - one or more magnetic field sensing elements disposed proximate to the current conductor portion;
  - a current sensing circuit disposed on the first surface of the substrate and coupled to the one or more magnetic

field sensing elements, wherein the current sensing circuit is adapted to provide an output signal indicative of a current flowing through the current conductor portion; and

an overcurrent circuit disposed on the first surface of the substrate, wherein the overcurrent circuit is adapted to sense a voltage drop associated with a current and further adapted to provide an output signal in response to the voltage drop, wherein the output signal is indicative of the current sensed by the overcurrent circuit being above a predetermined current.

2. The integrated circuit of claim 1, wherein the first surface of the substrate includes at least two conductive regions coupled to the overcurrent circuit, and wherein the current conductor portion includes at least two features adapted to contact the at least two conductive regions.

3. The integrated circuit of claim 1, wherein the first surface of the substrate includes at least two conductive regions coupled to the overcurrent circuit, and wherein the integrated circuit further comprises at least two wire bonds coupled between the at least two conductive regions and the current conductor portion.

4. The integrated circuit of claim 1, further comprising a second substrate disposed proximate to the current conductor portion, wherein the one or more magnetic field sensing elements are disposed on the second substrate.

5. The integrated circuit of claim 1, wherein the overcurrent circuit is coupled to the current conductor portion, wherein the voltage drop is associated with the current flowing through the current conductor portion, and wherein the output signal is indicative of the current flowing through the current conductor portion being above a predetermined current.

6. The integrated circuit of claim 1, wherein the overcurrent circuit is coupled to at least two of the plurality of leads, and wherein the voltage drop is associated with the current flowing through the current conductor portion.

7. The integrated circuit of claim 1, wherein the overcurrent circuit is coupled to at least two of the plurality of leads.

8. The integrated circuit of claim 1, wherein the output signal provided by the overcurrent circuit is adapted to affect the output signal provided by the current sensing circuit.

9. The integrated circuit of claim 1, wherein the output signal generated by the overcurrent circuit is a digital output signal having first and second states, wherein one of the first and second states is indicative of the current being above the predetermined current and the other one of the first and second states is indicative of the current being below the predetermined current.

10. The integrated circuit of claim 1, wherein the current conductor portion is a first current conductor portion, and wherein the integrated circuit further comprises:

a second current conductor portion deposited on the first surface of the substrate, disposed proximate to the one or more magnetic field transducers, and coupled to the first current conductor portion, wherein at least a portion of the current flowing through the first current conductor portion also flows through the second current conductor portion.

11. The integrated circuit of claim 1, wherein the substrate is disposed having the first surface of the substrate above the current conductor portion and the second surface of the

substrate above the first surface of the substrate when the plurality of leads is normally mounted to an uppermost surface of a circuit board.

12. The integrated circuit of claim 1, wherein the substrate is disposed having the second surface of the substrate above the current conductor portion and the first surface of the substrate above the second surface of the substrate when the plurality of leads is normally mounted to an uppermost surface of a circuit board.

13. The integrated circuit of claim 1, wherein the substrate has at least one bonding pad coupled to a corresponding one of the plurality of leads.

14. The integrated circuit of claim 1, wherein the substrate is coupled to at least one of the plurality of leads with a respective at least one of a solder ball, a gold bump, a eutectic or high lead solder bump, a no-lead solder bump, a gold stud bump, a polymeric conductive bump, an anisotropic conductive paste, or a conductive film.

15. A method of manufacturing an integrated circuit, comprising:

providing a lead frame portion having a plurality of leads comprising at least two leads forming a current conductor portion;

providing a substrate having first and second opposing surfaces;

forming one or more magnetic field sensing elements;

mounting the substrate to the lead frame portion so that the first surface of the substrate is proximate to the current conductor portion and the second surface of the substrate is distal from the current conductor portion;

forming a current sensing circuit on the first surface of the substrate, wherein the current sensing circuit is adapted to provide an output signal indicative of a current flowing through the current conductor portion; and

forming an overcurrent circuit on the first surface of the substrate, wherein the overcurrent circuit is adapted to sense a voltage drop associated with a current and further adapted to provide an output signal in response to the voltage drop, wherein the output signal is indicative of the current sensed by the overcurrent circuit being above a predetermined current.

16. The method of claim 15, wherein the first surface of the substrate includes at least two conductive regions coupled to the overcurrent circuit, and wherein the current conductor portion includes at least two features adapted to contact the at least two conductive regions.

17. The method of claim 15, wherein the first surface of the substrate includes at least two conductive regions coupled to the overcurrent circuit, and wherein the method further comprises forming at least two wire bonds coupled between the at least two conductive regions and the current conductor portion.

18. The method of claim 15, further comprising:

forming the one or more magnetic field sensing elements on a second substrate; and

mounting the second substrate proximate to the current conductor portion.

19. The method of claim 15, wherein the overcurrent circuit is coupled to the current conductor portion, wherein the voltage drop is associated with the current flowing

through the current conductor portion, and wherein the output signal is indicative of the current flowing through the current conductor portion being above a predetermined current.

20. The method of claim 15, wherein the overcurrent circuit is coupled to at least two of the plurality of leads, and wherein the voltage drop is associated with the current flowing through the current conductor portion.

21. The integrated circuit of claim 15, wherein the overcurrent circuit is coupled to at least two of the plurality of leads.

22. The method of claim 15, wherein the output signal provided by the overcurrent circuit is adapted to affect the output signal provided by the current sensing circuit.

23. The method of claim 15, wherein the output signal generated by the overcurrent circuit is a digital output signal having first and second states, wherein one of the first and second states is indicative of the current being above the predetermined current and the other one of the first and second states is indicative of the current being below the predetermined current.

24. The method of claim 15, wherein the current conductor portion is a first current conductor portion, and wherein the method further comprises:

depositing a second current conductor portion on the first surface of the substrate, disposed proximate to the one or more magnetic field sensing elements and coupled to the first current conductor portion, wherein at least a

portion of the current flowing through the first current conductor portion also flows through the second current conductor portion.

25. The method of claim 15, wherein the mounting the substrate comprises mounting the substrate such that the first surface of the substrate is above the current conductor portion and the second surface of the substrate is above the first surface of the substrate when the plurality of leads is normally mounted to an uppermost surface of a circuit board.

26. The method of claim 15, wherein the mounting the substrate comprises mounting the substrate such that the second surface of the substrate is above the current conductor portion and the first surface of the substrate is above the second surface of the substrate when the plurality of leads is normally mounted to an uppermost surface of a circuit board.

27. The method of claim 15, wherein the substrate has at least one bonding pad coupled to a corresponding one of the plurality of leads.

28. The method of claim 15, wherein the mounting the substrate to the lead frame portion comprises coupling the substrate to at least one of the plurality of leads with a respective at least one of a solder ball, a gold bump, a eutectic or high lead solder bump, a no-lead solder bump, a gold stud bump, a polymeric conductive bump, an anisotropic conductive paste, or a conductive film.

\* \* \* \* \*