

(19) World Intellectual Property Organization
International Bureau



(43) International Publication Date
18 July 2002 (18.07.2002)

PCT

(10) International Publication Number
WO 02/056097 A2

(51) International Patent Classification⁷: G02F

Rong-Chang [US/US]; 20142 Pacifica Drive, Cupertino, CA 95014 (US). TSENG, Scott, C., J. [—/US]; 1042 Reed Terrace #4, Sunnyvale, CA 94086 (US). PHAN, Xuan [US/US]; 2509 Sunnystone Way, Raleigh, NC 27613 (US). LI, Ying-Syi [—/US]; 1489 Shaffer Drive, San Jose, CA 95132 (US). LI, Weijin [CN/US]; 2390 Lucretia Avenue #807, San Jose, CA 95122 (US).

(21) International Application Number: PCT/US02/00602

(22) International Filing Date: 9 January 2002 (09.01.2002)

(25) Filing Language: English

(26) Publication Language: English

(74) Agents: CHOW, Y., Ping et al.; Heller Ehrman White & McAuliffe LLP, 275 Middlefield Road, Menlo Park, CA 94025-3506 (US).

(30) Priority Data:
09/759,212 11 January 2001 (11.01.2001) US

(71) Applicant (for all designated States except US): SIPIX IMAGING, INC. [US/US]; 1075 Montague Expressway, Milpitas, CA 95053 (US).

(81) Designated States (national): AE, AG, AL, AM, AT, AT (utility model), AU, AZ, BA, BB, BG, BR, BY, BZ, CA, CH, CN, CO, CR, CU, CZ, CZ (utility model), DE, DE (utility model), DK, DK (utility model), DM, DZ, EC, EE, EE (utility model), ES, FI, FI (utility model), GB, GD, GE, GH, GM, HR, HU, ID, IL, IN, IS, JP, KE, KG, KP, KR, KZ, LC, LK, LR, LS, LT, LU, LV, MA, MD, MG, MK,

(72) Inventors; and

(75) Inventors/Applicants (for US only): LIANG,

[Continued on next page]

(54) Title: AN IMPROVED TRANSMISSIVE OR REFLECTIVE LIQUID CRYSTAL DISPLAY AND NOVEL PROCESS FOR ITS MANUFACTURE

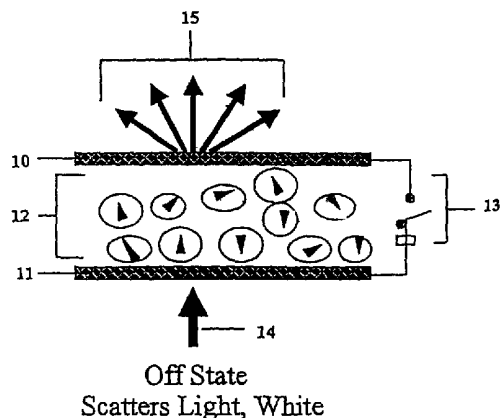

(57) Abstract: This invention relates to liquid crystal (LC) displays comprising cells of well-defined shape, size and aspect ratio which cells are filled with a liquid crystal composition preferably containing dichroic dye(s), and novel processes for their manufacture.

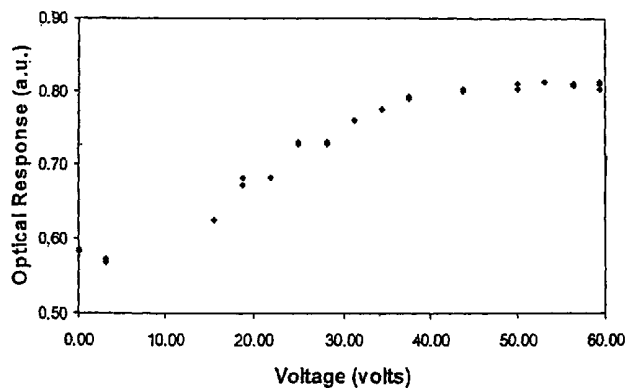

Hysteresis Curve of a LCD of the Current Invention



WO 02/056097 A2



MN, MW, MX, MZ, NO, NZ, OM, PH, PL, PT, RO, RU, SD, SE, SG, SI, SK, SK (utility model), SL, TJ, TM, TN, TR, TT, TZ, UA, UG, US, UZ, VN, YU, ZA, ZM, ZW.

(84) Designated States (regional): ARIPO patent (GH, GM, KE, LS, MW, MZ, SD, SL, SZ, TZ, UG, ZM, ZW), Eurasian patent (AM, AZ, BY, KG, KZ, MD, RU, TJ, TM), European patent (AT, BE, CH, CY, DE, DK, ES, FI, FR, GB, GR, IE, IT, LU, MC, NL, PT, SE, TR), OAPI patent (BF, BJ, CF, CG, CI, CM, GA, GN, GQ, GW, ML, MR, NE, SN, TD, TG).

Published:

— *without international search report and to be republished upon receipt of that report*

For two-letter codes and other abbreviations, refer to the "Guidance Notes on Codes and Abbreviations" appearing at the beginning of each regular issue of the PCT Gazette.

AN IMPROVED TRANSMISSIVE OR REFLECTIVE LIQUID CRYSTAL DISPLAY AND NOVEL PROCESS FOR ITS MANUFACTURE

BACKGROUND OF THE INVENTION

a) Field of the Invention

This invention relates to liquid crystal displays comprising cells of well-defined shape, size and aspect ratio, which are filled with liquid crystals, preferably with a guest dye, and novel processes for their manufacture.

b) Background

A polymer dispersed liquid crystal (PDLC) display usually comprises two transparent plates with electrodes placed opposing each other, separated by using spacers. A thin film of PDLC is enclosed between the two plates. The PDLC film may be up to 200 microns thick, but usually having a thickness of between 2 microns and 50 microns. The cell is hermetically sealed in order to eliminate oxygen and moisture, both of which may chemically attack the liquid crystals. A thorough review of the PDLC technologies can be found in the book "Liquid Crystal Dispersions" by P. S. Drzaic (1995).

A PDLC typically consists of micron-size droplets of a low-molecular-weight nematic liquid crystal dispersed in a polymer binder. The nematic droplets strongly scatter light and the material has a white opaque or translucent appearance ("off state"). When a voltage difference is imposed between the two electrodes ("on state"), the electric field aligns the droplets such that the ordinary refractive index of the liquid crystal nearly matches that of the isotropic polymer matrix, substantially reducing the scattering power of the droplets, and thus allowing light to transmit through. In the on state, the cell thus appears clear or transparent, in the off state it appears opaque.

In a guest-host PDLC display, a dye, particularly a pleochroic or dichroic dye, is added as a guest to the liquid crystal to produce a high color contrast display. For example, because the dye molecules have a property to orientate parallel to the liquid crystal molecules, if a dichroic dye having a bar-shaped structure is added to the liquid crystal, the direction of the dye molecules also changes if the molecular direction of the liquid crystal is changed by applying an electric field on the opposing electrodes. Because this dye is made colored or not depending on the orientation direction, it is

possible to switch between a colored state ("off state") and a colorless state ("on state") by applying a voltage on the two electrodes. The use of dichroic or pleochroic dyes in guest-host PDLC displays to improve the contrast ratio is well known in the art.

A PDLC display may be transmissive and/or reflective. A transmissive PDLC display has an internal illumination source. Imposing a voltage on the two electrodes allows light to pass through the cell. A typical example of a transmissive PDLC display is a PDLC overhead projector. Reflective PDLC displays typically contain a reflective black or colored filter which becomes visible in the transparent state. Reflective PDLC displays may be found in PDA (personal digital assistant) devices. Transmissive and reflective PDLC displays are particularly attractive because polarizers are eliminated. Polarizers substantially reduce light and decrease brightness of both direct view and projection displays. The absence of polarizers also gives a better viewing angle.

The PDLC displays prepared by prior art processes have many shortcomings. For example, the polymer dispersed liquid crystals typically have droplets of very broad particle size distribution, which results in significant hysteresis, higher operation voltage, poor contrast ratio, undesirable red bleedthrough, and low level of multiplexing. However, the hysteresis of PDLC films must be low to show reproducible gray scales, and low voltage operation and high contrast ratio of the device is essential for most PDA applications. Monodispersed liquid crystal particles in the micron size range have been taught in US 5,835,174, (Clikeman, et al.) 5,976,405 (Clikeman, et al.), and 6,037,058 (Clikeman, et al.) to reduce the hysteresis and operation voltage, and improve the level of multiplexity. The contrast ratio of PDLC device prepared from the monodispersed particles remains low for most applications. To improve the contrast ratio without trade off in the thickness of the PDLC film and operation voltage, guest dyes preferably, pleochroic dyes or dichroic dyes are needed. However, the prior art processes do not allow for the precise enclosure of a high concentration of guest dyes in the liquid crystal phase during the manufacturing process, such that only a low concentration of dyes may be encapsulated in the monodispersed polymer particles. Some guest dyes may be left outside of the particles, thereby resulting in an increase in D_{min} (the minimum optical density of the background) and a lower contrast ratio.

It is highly desirable to create monodispersed liquid crystal domains, which would alleviate the requirement of high operation voltage, allow high contrast ratio and high level of multiplexing, and reduce hysteresis.

SUMMARY OF THE INVENTION

The first aspect of the present invention is directed to a liquid crystal (LC) display comprising cells of substantially uniform shape, size and aspect ratio. The cells are filled with LC preferably with guest dye(s).

Another aspect of the invention relates to a novel process for the manufacture of such a LC display.

A further aspect of the invention relates to the preparation of cells of substantially uniform shape, size and aspect ratio. The cells enclose LC preferably with guest dye(s) and are formed from microcups prepared according to the present invention. Briefly, the process for the preparation of the microcups involves embossing a thermoplastic or thermoset precursor layer coated on a conductor film with a pre-patterned male mold, followed by releasing the mold before, during or after the thermoplastic or thermoset precursor layer is hardened by radiation, cooling, solvent evaporation, or other means. Alternatively, the microcups may be formed from imagewise exposure of the conductor film coated with a radiation curable layer followed by removing the unexposed areas after the exposed areas have become hardened.

Solvent-resistant, thermomechanically stable microcups having substantially monodispersed size and shape can be prepared by either one of the aforesaid methods. The size of microcups for most display applications is in the range of submicrons to 10 microns, more preferably 0.5 microns to 5 microns. The shape may be any shape, although a shape allowing a higher total area of interface between liquid crystal and the cups is preferred. The microcups are then filled with LC preferably with guest dye(s), and sealed.

Yet another aspect of the present invention relates to the sealing of the microcups filled with the LC preferable with guest dye(s). Sealing can be accomplished by a variety of ways. Preferably, it is accomplished by dispersing into the LC phase before the filling step, a sealant composition containing a thermoplastic or thermoset precursor. The sealant composition is immiscible with the LC and has a specific gravity lower than

that of the LC. After filling, the thermoplastic or thermoset precursor phase separates and forms a supernatant layer at the top of the LC. The sealing of the microcups is then conveniently accomplished by hardening the precursor layer by solvent evaporation, interfacial reaction, moisture, heat, or radiation. UV radiation is the preferred method to seal the microcups, although a combination of two or more curing mechanisms as described above may be used to increase the throughput of sealing. Alternatively, the sealing can be accomplished by overcoating the LC with a sealant composition containing the thermoplastic or thermoset precursor. The solvent used in the sealant composition is critical. Preferably, it is immiscible with the LC and has a specific gravity lower than that of the LC. It is also important to control the surface tension and viscosity of the sealant composition to ensure a good coating uniformity. The sealing is then accomplished by hardening the sealant composition by solvent evaporation, interfacial reaction, moisture, heat, radiation, or a combination of curing mechanisms. These sealing processes are also unique features of the present invention.

Yet another aspect of the present invention relates to the absence of the hysteresis of the LC displays. The LC displays of the present invention consist of substantially monodispersed microcups filled with liquid crystals and preferably a guest dye. The composition of the microcups is optimized such that the isotropic refractive index of the cups is matched to the ordinary refractive index of the LC. In a manner similar to conventional PDLC displays, the LC displays of the present invention strongly scatter light in the absence of an electric field (the "off state"). When a voltage difference is applied between the two electrodes, the electric field aligns the LC and substantially reduce scattering power and allow light to transmit through the "on state". However, unlike the PDLC displays, the LC displays of this invention reach the maximum optically clear state at a much lower voltage and, when the applied voltage is withdrawn, reverts back to the original "off" state without undesirable hysteresis. The low operation voltage, fast response time, and the absence of hysteresis of the displays of the present invention are critical for high quality display applications where low power consumption, reproducible gray scales and video rate are highly desirable.

Yet another aspect of the present invention relates to the manufacture of a LC display comprising stack of layers of microcups. The processing steps include preparation of the first layer of microcups on a conductor substrate by anyone of the

methods described above, filling the microcups with a LC composition, sealing, and finally laminating the sealed microcups with a second conductor substrate precoated with an adhesive layer. The adhesives can be hot-melt, heat curable, moisture curable, or radiation curable adhesives. Of particular interest, UV curable adhesives are used in the present invention. To improve the contrast ratio, more than one layer of the microcup array may be used. The processing steps include preparation of microcups, filling with the LC composition, sealing, overcoating or laminating the sealed microcup array with a second layer of the microcup forming composition, forming the second microcup array with any of the methods described previously, preferably by the embossing method, repeating several times the steps of filling and sealing of microcups, overcoating or laminating the sealed microcups with another layer of microcup forming composition, and finally laminating the stack of microcup layers to a second conductor substrate precoated with an adhesive layer.

Yet another aspect of the present invention relates to a process for the manufacture of a full color reflective LC display by using a conductor substrate precoated with (R, G, B) color filers and preferably a black matrix. Alternatively, a full color display can be prepared by laminating the preformed microcups with a layer of positively working photoresist, selectively opening a certain number of the microcups by imagewise exposing the positive photoresist, followed by developing the resist, filling the opened microcups with a LC composition containing guest dye(s), preferably dichroic dyes of the first color, and sealing the filled microcups by a sealing process described previously. These steps may be repeated to create sealed microcups filled with LC compositions containing guest dyes of the second or the third color. A black background may be used to improve the contrast ratio and color saturation.

These multiple-step processes as disclosed may be carried out roll-to-roll continuously or semi-continuously. Consequently, they are suitable for high volume and low cost production. These processes are also efficient and inexpensive as compared to other processes for high volume production operations. The LC display prepared according to the present invention is not sensitive to environment, particularly humidity and temperature. The display may be very thin, flexible, durable, easy-to-handle, and format-flexible. Since the LC display prepared according to the present invention comprises cells of favorable aspect ratio and substantially monodispersed shape and

size, the displays manufactured according to the present invention exhibit many desirable properties such as low power consumption, fast response time, high level of multiplexing, high contrast ratio, and reproducible gray scale presentation due to the absence of undesirable hysteresis.

BRIEF DESCRIPTION OF THE DRAWINGS

Figures 1a and 1b show the “off” and “on” states respectively of a typical PDLC device.

Figures 1c, 1d and 1e are schematic depictions of the LC displays of the present invention.

Figures 2a-2d illustrate a typical method of preparing the male mold for microembossing.

Figures 3a-3b show the roll to roll process for the manufacture of a LCD, in particular, the creation of microcups by embossing a conductor film coated with a UV curable composition.

Figures 4a-4b show two SEM micrographs of microcup arrays prepared by microembossing.

Figures 5a1, 5a2, 5b1, 5b2, 5c1, and 5c2 show alternative processing steps for preparing the microcups involving imagewise exposure of the conductor film coated with a thermoset precursor to UV radiation.

Figures 6a-6f show examples of different shapes and patterns of microcup arrays.

Figure 7 is a flow chart for manufacturing a monochrome LCD.

Figures 8a-8h show a process for the manufacturing of a full color display using three primary color guest dyes.

Figure 9a shows a typical hysteresis curve for a traditional PDLC device.

Figure 9b shows the absence of the hysteresis loop in a typical microcup LCD of this invention.

DETAILED DESCRIPTION OF THE INVENTION

Definitions

Unless defined otherwise in this specification, all technical terms are used herein according to their conventional definitions as they are commonly used and understood by those of ordinary skill in the art.

The term “microcup” refers to the cup-like indentations created by microembossing or imagewise exposure.

The term “cell”, in the context of the present invention, is intended to mean the single unit formed from a sealed microcup. The cells are filled with liquid crystals preferably with guest dye(s).

The term “well-defined”, when describing the microcups or cells, is intended to indicate that the microcup or cell has a definite shape, size and aspect ratio which are pre-determined according to the specific parameters of the manufacturing process.

The term “monodispersed”, when describing the microcups or cells, is intended to indicate that the microcup or cell has a narrow distribution of dimensions such as diameter, length, width, and height.

The term “aspect ratio” is a commonly known term in the art of PDLC displays. In this application, it refers to the depth to width or depth to length ratio of the microcups.

Preferred Embodiments

A typical PDLC display, as shown in Figure 1a, comprises two electrode plates (10, 11), at least one of which is transparent (10), and a layer of liquid crystal domains dispersed in an isotropic polymer matrix. Figure 1a also shows the random direction of the liquid crystal molecules when no voltage (13) is imposed on the two electric plates (10,11). The incoming light (14) is thus scattered (15) by the random orientation of the liquid crystal molecules

Figure 1b shows that the liquid crystal molecules are lined up in a certain direction when voltage (13) is imposed on the two electric plates. Incoming light (16) thus is transmitted through (17) because the ordinary refractive index of the liquid crystal is matched to the isotropic refractive index of the polymer matrix (12).

A monochrome liquid crystal display of the present invention, schematically shown in Figure 1c comprises well-defined cells (18) enclosed between the two electrodes (10, 11). The cells (18) are of substantially uniform shape and size and are filled with a LC composition. The electrode on the viewer’s side is transparent and at least one of the two electrodes is patterned. A full range of color is obtained if three primary color filters (19), such as red (R), green (G), and blue (B), are used (Figure 1d).

Alternatively, a full color display of the present invention may be obtained by filling the well-defined cells (1, 2 and 3) with a LC composition containing R, G, and B guest dyes, preferably dichroic dyes respectively. For example, the cells (1) are filled with LC with a red guest dye, adjacent cells (2) are filled with LC with a green guest dye, and adjacent cells (3) are filled with LC with a blue guest dye. The number of layers of the cells containing LC may be more than one (Figure 1e).

The process for the preparation of such LC displays involves several aspects.

I. Preparation of the Microcups

(a) Preparation of the Male Mold

The male mold may be prepared by a photoresist process followed by either etching or electroplating. A representative example for the preparation of the male mold is given in Figures 2a-2d. With electroplating (Figure 2a), a glass base (20) is sputtered with a thin layer (typically 3000 Å) of a seed metal (21) such as chrome inconel. It is then coated with a layer of photoresist (22) and exposed to UV. A mask (24) is placed between the UV and the layer of photoresist (22). The exposed areas of the photoresist become hardened. The unexposed areas are then removed by washing them with an appropriate solvent. The remaining hardened photoresist is dried and sputtered again with a thin layer of seed metal. A master (Figure 2b) is then ready for electroforming. A typical material used for electroforming is nickel cobalt (23). Alternatively, the master can be made of nickel by nickel sulfamate electroforming or electroless nickel deposition as described in "Continuous manufacturing of thin cover sheet optical media", SPIE Proc. Vol. 1663, p. 324 (1992). The floor of the mold (Figure 2d) is typically between 1 to 5 microns. The master can also be made using other microengineering techniques including e-beam writing, dry etching, chemical etching, laser writing or laser interference as described in "Replication techniques for micro-optics", SPIE Proc. Vol. 3099, pp. 76-82 (1997). Alternatively, the mold can be made by photomachining using plastics, ceramics or metals.

(b) Preparation of the Microcups by Embossing

This processing step is shown in Figures 3a and 3b. The male mold (30) may be placed either above (Figure 3a) or below (Figure 3b) the web (34). The transparent conductive substrate is constructed by forming a transparent conductor film (31) on a

glass plate or a plastic substrate. A layer of a thermoplastic or thermoset precursor (32) is then coated on the conductor film. The thermoplastic or thermoset precursor layer is embossed at a temperature higher than the glass transition temperature of the thermoplastic or thermoset precursor layer by the male mold in the form of a roller, plate or belt.

The thermoplastic or thermoset precursor (32) for the preparation of the microcups (33) may be multifunctional acrylate or methacrylate, vinyl ether, epoxide and their oligomers, polymers and the like. Multifunctional acrylate and their oligomers are the most preferred. A combination of multifunctional epoxide and multifunctional acrylate is also very useful to achieve desirable physico-mechanical properties. A crosslinkable oligomer imparting flexibility, such as urethane acrylate or polyester acrylate, is usually also added to improve the flexure resistance of the embossed microcups. The composition may contain polymer, oligomer, monomer and additives or only oligomer, monomer and additives. The glass transition temperatures (or T_g) for this class of materials usually range from about -70°C to about 150°C, preferably from about -20°C to about 50°C. The microembossing process is typically carried out at a temperature higher than the T_g. A heated male mold or a heated housing substrate against which the mold presses may be used to control the microembossing temperature and pressure.

As shown in Figures 3a and 3b, the mold is released during or after the precursor layer is hardened to reveal an array of microcups (33). The hardening of the precursor layer may be accomplished by cooling, cross-linking by radiation, heat or moisture. If the curing of the thermoset precursor is accomplished by UV radiation, UV may radiate onto the transparent conductor film from the bottom or the top of the web (34) as shown in the two figures. Alternatively, UV lamps may be placed inside the mold. In this case, the mold must be transparent to allow the UV light to radiate through the pre-patterned male mold on to the thermoset precursor layer.

Figures 4a and 4b show SEM micrographs of two microcup arrays prepared by microembossing.

(c) Preparation of the Microcups by Imagewise Exposure

Alternatively, the microcups may be prepared by imagewise exposure (Figure 5a) of a radiation curable material (51) coated on the conductor film (52) to UV or other forms of radiation through a mask (50). The conductor film (52) is on a plastic substrate (53).

For a roll-to-roll process, the photomask may be synchronized with the web and move at the same speed as the latter. In the photomask (50) in Figure 5a, the dark squares (54) represent the opaque area and the space (55) between the dark squares represents the opening area. The UV radiates through the opening area (55) onto the radiation curable material. The exposed areas become hardened and the unexposed areas (protected by the opaque area in the mask) are then removed by an appropriate solvent or developer to form the microcups (56). The solvent or developer is selected from those commonly used for dissolving or dispersing the radiation curable materials such as methylethylketone, toluene, acetone, isopropanol or the like.

Figures 5b and 5c illustrate two other options for the preparation of microcups by imagewise exposure. The features in these two figures are essentially the same as shown in Figure 5a and the corresponding parts are also numbered the same. In Figure 5b, the conductor film (52) used is opaque and pre-patterned. In this case, it may be advantageous to imagewise expose the radiation sensitive material through the conductor pattern, which serves as the photomask. The microcups (56) can then be formed by removing the unexposed areas after UV radiation. In Figure 5c, the conductor film (52) is also opaque and line-patterned. The radiation curable material is exposed from the bottom through the conductor line pattern (52), which serves as the first photomask. A second exposure is performed from the other side through the second photomask (50) having a line pattern perpendicular to the conductor lines. The unexposed area is then removed by a solvent or developer to reveal the microcups (56).

In general, the microcups (56) can be of any shape to maximize the light scattering effect of the liquid crystal domains. The microcups are of substantially uniform size and shape in one system. However, microcups having different shapes and sizes may be used for different colors. For example, microcups filled with LC with a red guest dye may have a different shape or size from the green microcups or the blue

microcups. Furthermore, a pixel may consist of different numbers of microcups of different colors. Also, a pixel may consist of a number of small green microcups, a number of large red microcups, and a number of small blue microcups. It is not necessary to have the same shape and number for the three colors. Figures 6a-6f illustrate six examples of microcup patterns that may be used in the present invention.

The openings of the microcups may be round, square, rectangular, hexagonal, or any other shape. The partition area between the openings is preferably kept small in order to achieve a high color saturation and contrast ratio while maintaining desirable mechanical properties.

For LC displays of the present invention, the dimension of each individual microcup may be in the range of about 0.04 to about 100 μm^2 , preferably from about 0.6 μm^2 to about 36 μm^2 . The depth of the microcups is in the range of about 1 to about 10 microns, preferably from about 2 to about 6 microns. The opening to wall ratio is in the range of from about 0.05 to about 20, preferably from about 0.2 to about 10. The distances of the openings usually are in the range of about 0.5 to about 6 microns preferably from about 1 to about 4 microns from edge to edge of the openings

II. Liquid Crystals, Dichroic Dyes and Their Mixtures

The thus-formed array of microcups is filled with liquid crystals, usually by a coating process. Liquid crystals may also contain a dichroic dye to impart a monochrome color to the display and to increase the contrast.

Liquid crystal materials that may be used in the present invention are well known in the art. Examples of liquid crystal materials that may be used in the present invention include, but not limited to, E7, TL205, TL213, BL006, BL009 and BL037 from E. Merck Co. (Germany). Other liquid crystal materials are also listed in U.S. Patent 5,835,174 (Clikeman, et al.). Cholesteric liquid crystals may also be used in some applications.

Liquid crystals in the present invention are preferred to contain guest dye(s). Guest dyes of the present invention are dichroic and are well known in the art. See U.S. Patent 5,589,100 (Grasso, et al) stating that arylazo or poly(arylazo) dichroic dyes may be used with liquid crystal as well as listing other dichroic dyes suitable for the present invention.

The incorporation of dyes not only adds color but also can substantially improve contrast in some display applications. To be suitable, dyes must have high order parameters and proper solubility in the host liquid crystal material. High order parameter is promoted by dyes with elongated shape having a large ratio of molecular length to width, similar to the shape of the molecules of liquid crystal host material. The LC with guest dye(s) should provide good viewing characteristics, such as high contrast, high extinction, and chemical and photochemical stability. Example of dichroic dyes having a high dichroic ratio used in the present invention include the Blue AB2, Red AR1 and Yellow AG1 from Funktionfluid Gmb (Germany) and SI-486 (yellow), SI426 (red), M483 (blue), S344 (black), S428 (black) and S7 (black) from Mitsui Toatsu.

Nonionic azo and anthraquinone dyes are also useful. Examples include, but are not limited to: Oil Red EGN, Sudan Red, Sudan Blue, Oil Blue, Macrolex Blue, Solvent Blue 35, Pylam Spirit Black and Fast Spirit Black from Pylam Products Co., Arizona, Sudan Black B from Aldrich, Thermoplastic Black X-70 from BASF, anthroquinone blue, anthroquinone yellow 114, anthroquinone red 111, 135, anthroquinone green 28 from Aldrich. In any case, the dye must be chemically stable and should have a low solubility in the microcup material. Liquid crystals or dyes should not at any time attack the microcups.

III. Sealing of the Microcups

The sealing of the microcups may be accomplished in a number of ways. A preferred approach is to disperse a UV curable sealant composition into the LC composition. The UV curable composition is immiscible with and has a specific gravity lower than that of the LC. The UV curable composition and the LC composition, are thoroughly blended in an in-line mixer and immediately coated onto the microcups with a precision coating mechanism such as Myrad bar, gravure, doctor blade, slot coating or slit coating. Volatile solvents may be used to control the viscosity, the coverage of the coating, and facilitate the phase separation of the sealant phase from the LC phase. Excess fluid may be scraped away by a wiper blade or a similar device. The thus-filled microcups are then dried and the UV curable composition floats to the top of the LC. The microcups may be sealed by curing the supernatant UV curable layer during or after it floats to the top. UV or other forms of radiation such as visible light, IR and electron

beam may be used to cure and seal the microcups. Alternatively, heat or moisture, or the combination may also be employed to cure and seal the microcups, when heat or moisture curable sealant compositions are used.

Surfactants may be used to improve the adhesion of the sealant to the microcup wall and the wetting at the interface between the LC and the sealing materials. Useful surfactants include the FC surfactants from 3M Company, Zonyl fluorosurfactants from DuPont, fluoroacrylates, fluoromethacrylates, fluoro-substituted long chain alcohols, perfluoro-substituted long chain carboxylic acids and their derivatives, and Silwet surfactants from OSi.

Alternatively, the LC and the sealant composition may be coated sequentially into the microcups. Thus, the sealing of the microcups may be accomplished by overcoating a thin layer of thermoplastic or a thermoset precursor composition which is curable by radiation, heat, moisture or interfacial reactions and curing on the surface of the filled microcups. Interfacial polymerization followed by UV curing is very beneficial to the sealing process. Intermixing between the LC layer and the overcoat can be significantly suppressed by the formation of a thin barrier layer at the interface by interfacial polymerization. The sealing is then completed by a post curing step, preferably by UV radiation. To further reduce the degree of intermixing, it is highly desirable that the specific gravity of the overcoating is lower than that of the LC. Volatile organic solvents may be used to adjust the viscosity and the thickness of the coatings. When a volatile solvent is used in the overcoat, it is preferred that it is immiscible with the LC or the dye and has a specific gravity lower than that of the LC phase. The two-step overcoating process is particularly useful when the dye used is at least partially soluble in the sealant layer. To further reduce the degree of intermixing between the sealant layer and the LC phase, the filled microcup array may be chilled before overcoating of the sealant layer.

Alternatively, sealing of the filled microcups may be achieved by transfer laminating an adhesive layer from a release substrate onto the filled microcups, preferably followed by hardening the adhesive layer by heat, radiation or by simple solvent evaporation, and finally peeling off the release substrate. Chilling of the filled microcups is also beneficial to the sealing by transfer lamination process.

IV. Preparation of Monochrome LC displays

The process is illustrated by the flow diagram as shown in Figure 7. All microcups are filled with LC containing the same color guest dye(s). The process can be a continuous roll-to-roll process comprising the following steps:

1. Coat a layer of thermoplastic or thermoset precursor (70) optionally with a solvent onto a transparent conductor film (71). The solvent, if present, readily evaporates.
2. Emboss the thermoplastic or thermoset precursor layer at a temperature higher than the glass transition temperature of the thermoset precursor layer by a pre-patterned male mold (72).
3. Release the mold from the thermoplastic or thermoset precursor layer preferably during or after it is hardened by proper means.
4. Fill in the thus-formed array of microcups (73) with a LC composition (74) containing a thermoset precursor composition, which is incompatible with the LC and has a lower specific gravity than the LC phase.
5. Seal the microcups by hardening the thermoset precursor preferably by solvent evaporation, radiation such as UV (75), or by heat or moisture during or after the thermoset precursor separates and forms a supernatant layer on top of the LC phase, thus forming closed LC cells containing LC and preferably guest dye(s).
6. Laminate the sealed array of LC cells with a second conductor film (76) pre-coated with an adhesive layer (77) which may be a pressure sensitive adhesive, a hot melt adhesive, a heat, moisture, or radiation curable adhesive.

The laminate adhesive may be hardened by heat or radiation such as UV (78) through the top conductor film if the latter is transparent to the radiation. The laminated product may be cut (79) to appropriate size for device assembling.

The preparation of the microcups described above can be conveniently replaced by the alternative procedure of imagewise exposing the conductor film coated with a thermoset precursor followed by removing the unexposed areas by an appropriate solvent. The sealing of the microcups may alternatively be accomplished by the overcoating or transfer lamination processes described previously, followed by hardening the sealant over the surface of the filled microcups.

To improve the contrast ratio, more than a layer of the microcup array can be used (Figure 1c). Thus, after hardening the sealant layer on the filled microcups (the Step 5), another layer of microcup forming composition is coated onto the sealed microcup array. The Steps 2-5 can be repeated several times until an appropriate contrast ratio is achieved. The multilayer microcup stack is then laminated with a second conductor layer, and cut to appropriate size for display assembly. It is important to note that at least one of the two conductor films is prepatterned. Also, at least the conductor film at the viewer's side is transparent.

V. Preparation of Multi-Color LC displays

A multi-color LC display of the present invention can be prepared by using (R, G, B) color filters and a black matrix underneath the monochrome display prepared in the previous section (Figure 1d). Alternatively, a full color display of the present invention can be prepared by filling microcups with LC containing guest dye(s) of different colors (Figure 1e). In addition to processes described in the preparation of monochrome displays, additional steps are required for such a color display. These additional steps include (1) laminating the already formed microcups with a positively working dry-film photoresist consisting of at least a removable support such as PET-4851 from Saint-Gobain, Worcester, MA, a novolac positive photoresist such as Microposit S1818 from Shipley, and an alkali-developable adhesive layer such as a mixture of Nacor 72-8685 from National Starch and Carboset 515 from BF Goodrich; (2) selectively opening a certain amount of the microcups by imagewise exposing the photoresist, removing the removable support film, and developing the positive photoresist with a developer such as diluted Microposit 351 developer from Shipley; (3) filling the opened cups with the LC with guest dye(s) of the first primary color; and (4) sealing the filled microcups as described in the preparation of monochrome displays. These additional steps may be repeated to create microcups filled with LC of the second and the third primary colors.

More specifically, a multi-color LC display may be prepared according to the steps as shown in Figure 8:

1. Coat a layer of thermoset precursor (80) on a conductor film (81).

2. Emboss the thermoplastic or thermoset precursor layer at a temperature higher than its glass transition temperature by a pre-patterned male mold (not shown).
3. Release the mold from the thermoplastic or thermoset precursor layer preferably during or after it is hardened by solvent evaporation, cooling, or crosslinking by radiation, heat or moisture.
4. Laminate the thus formed array of microcups (82) with a positive dry-film photoresist, which comprises at least a positive photoresist (84) and a removable plastic cover sheet (not shown). The positive dry film photoresist may comprise an adhesive layer (83) to improve the adhesion between the microcups and the resist.
5. Imagewise expose (Figure 8c) the positive photoresist by UV, visible light, or other radiation, remove the cover sheet, develop and open cups in the exposed area. The purpose of Steps 4 and 5 is to selectively open the microcups in a predetermined area (Figure 8d).
6. Fill in the opened microcups with a LC composition containing guest dye(s) (85) of the first primary color and a sealant composition (86), which is incompatible with the LC phase and has a lower specific gravity than the LC phase.
7. Seal the microcups to form closed LC cells containing LC with guest dye(s) of the first primary color by hardening the sealant layer by solvent evaporation or curing preferably by radiation such as UV, less preferably by heat or moisture during or after the sealant separates and forms a supernatant layer on top of the liquid crystal phase (Figure 8e).
8. Steps 5-7 described above may be repeated to generate well-defined cells containing LC with guest dye(s) of different colors in different areas (Figures 8e, 8f and 8g).
9. Laminate the sealed array of LC cells to a second transparent conductor film (87) pre-coated with an adhesive layer (88) which may be a pressure sensitive adhesive, a hot melt adhesive, a heat, moisture, or radiation curable adhesive.
10. Harden the adhesive.

The preparation of the microcups described in the process above can conveniently be replaced by the alternative procedure of imagewise exposing the conductor film coated with a thermoset precursor followed by removing the unexposed areas by an appropriate solvent. The sealing of the microcups may be alternatively

accomplished by directly coating a layer of the thermoset precursor material over the surface of the liquid phase.

The thickness of the display produced by the present processes as described can be as thin as a piece of paper. The width of the display is the width of the coating web (typically 3-90 inches). The length of the display can be anywhere from inches to thousands of feet depending on the size of the roll.

EXAMPLES

The following examples are given to enable those skilled in the art to more clearly understand and to practice the present invention. They should not be considered as limiting the scope of the invention, but merely as being illustrative and representative thereof.

Example 1

Preparation of Microcups by Microembossing

The composition shown in Table 1 was Myrad bar #6 coated onto a 2mil PET film precoated with an ITO conductor layer from Sheldahl (Northfield, MN). A pre-patterned (4x4x4 microns) cobalt nickel male mold and a mold release Frekote 700-NC from Henkel were used for microembossing. The coating thickness was controlled to be about 5 microns. The coated film is then embossed by the stencil using a pressure roller at 90 °C. The coating is then UV-cured for about 1 minute through the Mylar film using a Cure Zone exposure unit (ADAC Technologies) equipped with a metal fluoride lamp with an intensity of 80 mW/cm² at 365 nm. The embossed film is then released from the mold to reveal well-defined (4x4x4 microns) microcups. The microembossing was carried out using the GBC Laminator at 90 °C.

Table 1: UV-curable Acrylate Formulation for Microcups

No.	Description	Ingredient	Supplier	Parts
1	Epoxy acrylate	Ebecryl 600	UCB Chemicals	55
2	Polyester acrylate	Ebecryl 830	UCB Chemicals	15
3	Urethane acrylate	Ebecryl 6700	UCB Chemicals	10
4	Silicon Acrylate	Ebecryl 350	UCB Chemicals	5
5	Monomer	Sartomer SR238	Sartomer	10
6	Monomer	Sartomer SR306	Sartomer	5
7	Monomer	Sartomer SR351	Sartomer	5
8	Photoinitiator	Irgacure 500	Ciba	1
9	Synergist	Methyl diethanol amine	Aldrich	0.5
10	Solvent	MEK	Aldrich	100

Example 2**Preparation of Microcups by Microembossing**

The same as Example 1 except the formulation shown in Table 2 was coated and embossed with a male mold of 4x4x4 microns.

Table 2: UV-curable Acrylate Formulation for Microcups

No.	Description	Ingredient	Supplier	Parts
1	Epoxy acrylate	Ebecryl 600	UCB Chemicals	50
2	Polyester acrylate	Ebecryl 830	UCB Chemicals	15
3	Urethane acrylate	Ebecryl 6700	UCB Chemicals	10
4	Silicon acrylate	Ebecryl 350	UCB Chemicals	5
5	Monomer	Poly(ethylene glycol) methacrylate	Aldrich	5
6	Monomer	Sartomer SR238	Sartomer	5
7	Monomer	Sartomer SR306	Sartomer	5
8	Monomer	Sartomer SR351	Sartomer	5
9	Photoinitiator	Irgacure 907	Ciba	0.5
10	Solvent	MEK	Aldrich	300

A Myrad bar # 12 was used. The controlled thickness was 5 microns. The microembossing was carried out using a pressure roller (GBC Laminator) heated at 90 °C.

Example 3**Preparation of Microcups by Microembossing**

The composition shown in Table 3 was laminated using a pressure roller between a 2 ml PET film precoated with an ITO conductor layer, and a pre-patterned (4x4x4 microns) cobalt nickel mold. The PET/ITO film was treated a corona discharge (Electro-Technic Products, Model BD-10A, Chicago, IL) for 5 sec. The cobalt nickel mold was pretreated with a mold release Frekote 750-NC. The coating was then UV cured for 1 min through the PET/ITO film. The embossing film was then released from the mold to reveal well-defined (4x4x4 microns) microcups with a thickness of 5.5 microns as measured by a Mituyoto thickness gauge.

Table 3: UV-curable Acrylate Formulation for Microcups

No.	Description	Ingredient	Supplier	Parts
1	Epoxy acrylate	Ebecryl 600	UCB Chemicals	40
2	Polyester acrylate	Ebecryl 830	UCB Chemicals	15
3	Urethane acrylate	Ebecryl 6700	UCB Chemicals	10
4	Silicon acrylate	Ebecryl 350	UCB Chemicals	5
5	Monomer	Poly(ethylene glycol) methacrylate	Aldrich	15
6	Monomer	Sartomer SR238	Sartomer	5
7	Monomer	Sartomer SR306	Sartomer	5
8	Monomer	Sartomer SR351	Sartomer	5
9	Photoinitiator	Irgacure 907	Ciba	0.5

Example 4**Preparation of Filled Microcups with Liquid Crystal Solution**

The microcups generated in Example 3 were washed with hexanes, then with MEK, and oven dried (66 °C) for 10 min. A liquid crystal BL006 (E. Merck Co., Germany) solution containing 1wt% Silwet L7608 (OSi Specialties) was mixed with 9 times volume of MPK, and the resulting solution was coated on microcup using Myrad bar #16. Excess solvent in the microcup was evaporated in oven (66 °C) for 10 min.

Example 5

Preparation of Filled Microcups with Liquid Crystal Solution Containing Blue Dichroic Dye

The microcups generated in Example 3 were washed with hexanes, then with MEK, and oven dried (66 °C) for 10 min. A liquid crystal BL006 (E. Merck Co., Germany) solution containing 3wt% dichroic dye Blue AB2 (Funktionfluid Gmb, Germany) and 1wt% Silwet L7608 (OSi Specialties) was mixed with 9 times volume of MPK, and the resulting solution was coated on microcup using Myrad bar #16. Excess solvent on the microcup was evaporated in oven (66 °C) for 10 min.

Example 6

Preparation of Filled Microcups with Liquid Crystal Solution Containing Black Dichroic Dye Mixture

The microcups generated in Example 3 were washed with hexanes, then with MEK, and oven dried (66 °C) for 10 min. A black dichroic dye mixture was prepared by mixing three dichroic dyes Blue AB2, Red AR1, and Yellow AG1 (Funktionfluid Gmb, Germany) together. A liquid crystal BL006 (E. Merck Co., Germany) solution containing 2wt% black dichroic dye mixture and 1wt% Silwet L7608 (OSi Specialties) was mixed with 9 times volume of MPK, and the resulting solution was coated on microcup using Myrad bar #16. Excess solvent on the microcup was evaporated in oven (66 °C) for 10 min.

Example 7

Sealing the Microcups by a Two-step (Overcoating) Process

A 10% solution of Vistalon 0106 (Exxon Mobil Chemicals) in Isopar E (Exxon Chemical) was coated onto a BL006-filled microcup sample prepared in Example 4, 5 and 6. The coating layer was uniform and transparent. By using a #3 Myrad bar, a sealing polymer layer with the weight coverage of 0.39 mg/in² was obtained and the thickness of the sealing polymer layer was estimated to be 0.7 μ. By using a #8 Myrad bar, a sealing polymer layer with the weight coverage of 0.75 mg/in² was obtained and the thickness of the sealing polymer layer was estimated to be 1.3 μ. The density of Vistalon 0106 is about 0.9 g/cm³.

Example 8

Sealing the Microcups by a Two-step (Overcoating) Process

Following the same procedure of Example 7, the microcups were sealed by coating a 10% solution of a carboxylated acrylic copolymer, Amphomer 28-4910 (National Starch) in 2-propanol onto the BL006-filled microcups as prepared in Example 5. The coating layer is uniform and transparent. By using a #3 Myrad bar, a sealing polymer layer with the weight coverage of 0.44 mg/in^2 was obtained and the thickness of the sealing polymer layer was estimated to be 0.6μ . By using a #8 Myrad bar, a sealing polymer layer with the weight coverage of 1.0 mg/in^2 was obtained and the thickness of the sealing polymer layer was estimated to be 1.3μ . The density of Amphomer 28-4910 is about 1.2 g/cm^3 .

Example 9

Traditional Polymerization Induced Phase Separation PDLC Display

For comparison, a traditional polymerization induced phase separation polymer disperse liquid crystal display was prepared. Different ratio of liquid crystal E7 (E. Merck, Germany) to Norland 65 (Norland) were mixed and sandwiched between two ITO coated glasses with spacer either $4.5 \mu\text{m}$, $25 \mu\text{m}$ or $50 \mu\text{m}$. Step wedge was used to optimize the UV-curing time under Cure Zone exposure unit (ADAC Technologies). Figure 8a shows a typical hysteresis curve for polymerization induced phase separation PDLC prepared with the above procedure.

Example 10

SIPix Hysteresis-Free Liquid Crystal Display

A single layer liquid crystal display was assembled using microcup prepared in example 1, 2 or 3. Liquid crystal with or without dichroic dye(s) was filled into microcup with procedure described in example 4, 5 and 6. These LC-filled microcups were then sealed with procedure described in example 7 or 8. No hysteresis was observed for liquid crystal displays made according to the present invention. (see Figure 8b)

Example 11**Assembling of a multilayer display and it's performance**

Multilayer liquid crystal display was assembled to improve display performance. Single layer liquid crystal display was made as described in example 10. Same procedure was used to emboss a second layer of microcup on top of the first LC display, to fill LC with or without dye and to seal the second layer of LC display. The registration of second layer microcup on the first layer was set to be off from the first layer about 0 to 10 degree to maximum light scattering. Laminate two double-layer arrays to stack up a four-layer liquid crystal display. A high contrast display was obtained with rising and falling response time of ~1 msec and ~10 msec (at 40 volts) respectively. No hysteresis loop was observed.

WE CLAIM:

1. A LC display comprising a plurality of cells having well-defined size, shape and aspect ratio, said cells filled with a liquid crystal composition.
2. The LC display of Claim 1 wherein the cells are substantially uniform in size and shape.
3. The LC display of Claim 1 wherein the cells are non-spherical.
4. The LC display of Claim 1 wherein the cells are formed from microcups with an opening area ranging from about 0.04 to about 100 μm^2 .
5. The LC display of Claim 4 wherein the cells are formed from microcups with an opening area ranging from about 1 to about 25 μm^2 .
6. The LC display of Claim 1 wherein the cells are formed from microcups with an opening having a circular, polygonal, hexagonal, rectangular or square shape.
7. The LC display of Claim 1 wherein the cells have a depth in the range from about 0.5 to about 10 microns.
8. The LC display of Claim 7 wherein the cells have a depth in the range from about 2 to about 6 microns.
9. The LC display of Claim 1 wherein the cells have an opening to wall ratio in the range from about 0.05 to about 20.
10. The LC display of Claim 9 wherein the cells have an opening to wall ratio in the range from about 0.2 to about 9.
11. The LC display of Claim 1 wherein selected cells in a pre-determined area are filled with LC with guest dye(s) of a predetermined color.
12. The LC display of Claim 11 wherein cells which are filled with LC with guest dye(s) of a predetermined color are adjacent to each other.

13. The LC display of Claim 11 wherein cells which are filled with LC with guest dye(s) of a predetermined color are stacked on top of each other.
14. A process for the preparation of well-defined cells of substantially uniform size and shape to be used in a LC display, which process comprises the steps of:
 - a) coating a layer of thermoplastic or thermoset precursor on a conductor film;
 - b) embossing the thermoplastic or thermoset precursor layer with a pre-patterned male mold;
 - c) releasing the mold from the thermoplastic or thermoset precursor layer;
 - d) hardening the thermoplastic or thermoset precursor layer; and
 - e) filling the thus-formed array of microcups with LC.
15. The process of Claim 14 wherein said thermoset precursor is selected from the group consisting of polyvalent acrylate or methacrylate, polyvalent vinyl including vinylbenzene, vinylsilane, vinyl ether, polyvalent epoxide, polyvalent allyl, and oligomers, polymers containing crosslinkable functional groups, and the like.
16. The process of Claim 14 wherein the thermoplastic or thermoset precursor layer is embossed at a temperature near or above its glass transition temperature.
17. The process of Claim 16 wherein the glass transition temperature ranges from about -70°C to about 150°C.
18. The process of Claim 16 wherein the glass transition temperature ranges from about -20°C to about 100°C.
19. The process of Claim 14 wherein the hardening of the thermoset precursor layer is accomplished by cross-linking by radiation, heat, moisture, cooling or evaporation of a solvent or plasticizer.
20. The process of Claim 14 wherein the hardening of the thermoset precursor layer is accomplished by UV, visible light, near IR, or electron beam radiation.

21. The process of Claim 14 wherein the pre-patterned male mold is released before, during or after the thermoplastic or thermoset precursor layer is hardened.
22. A process for the preparation of well-defined cells of substantially uniform size and shape to be used in a LC display, which process comprises the steps of:
- a) coating a layer of radiation curable composition on a conductor film;
 - b) imagewise exposing the radiation curable layer;
 - c) removing the unexposed areas by a developer or solvent to reveal an array of microcups; and
 - d) filling the microcups with LC.
23. The process of Claim 22 wherein the microcups are filled with LC and guest dye(s).
24. The process of Claim 22 wherein said radiation curable composition comprises materials selected from the group consisting of polyvalent acrylate or methacrylate, polyvalent vinyl including vinylbenzene, vinylsilane, vinyl ether, polyvalent epoxide, polyvalent allyl, oligomers or polymers containing crosslinkable functional groups, and the like.
25. The process of Claim 22 wherein the imagewise exposure is accomplished by UV, visible light, near IR, or electron beam radiation.
26. A process for the preparation of an array of well-defined cells used in a LC display, which process comprises the steps of:
- a) filling the microcups with a liquid crystal composition and a dispersion of thermoset or thermoplastic precursor composition which has a specific gravity lower than that of the LC; and
 - b) sealing the microcups by hardening the thermoset or thermoplastic precursor composition during or after it phase separates and forms a supernatant layer above the LC.
27. The process of Claim 26 wherein the liquid crystal composition comprises guest dye(s).

28. The process of Claim 26 wherein the thermoset or thermoplastic precursor composition comprises materials selected from the group consisting of acrylates or methacrylates, vinyls, polyvalent acrylates or methacrylates, cyanoacrylates, polyvalent vinyls including vinylbenzene, vinylsilane, vinylether, polyvalent epoxides, polyvalent isocyanates, polyvalent allyls, and oligomers or polymers derived therefrom, and the like.

29. The process of Claim 28 wherein the oligomers or polymers are derived from those containing crosslinkable functional groups.

30. A process for the preparation of well-defined cells used in a LC display, which process comprises the steps of:

- a) filling the microcups with a LC composition,
- b) sealing the microcups by overcoating onto the said LC filled microcups a thermoset or thermoplastic precursor composition which is at least partially immiscible with said LC and has a specific gravity lower than that of said LC, and
- c) hardening said thermoplastic or thermoset precursor composition.

31. The process of Claim 30 wherein the thermoplastic or thermoset precursor composition is diluted with a volatile solvent or solvent mixture which is evaporated after said composition is coated onto the LC.

32. The process of Claim 30 wherein the overcoated thermoset precursor composition is cured by radiation, heat, moisture, or interfacial reactions at the interface between the overcoat and the LC.

33. The process of Claim 30 wherein the thermoplastic or thermoset precursor composition comprises materials selected from the group consisting of acrylates or methacrylates, vinyls, polyvalent acrylates or methacrylates, cyanoacrylates, polyvalent vinyls including vinyl benzene, vinylsilanes, vinyl ethers, polyvalent epoxides, polyvalent isocyanates, polyvalent allyls, oligomers or polymers derived therefrom, and the like.

34. The process of Claim 33 wherein the oligomers or polymers are derived from those containing crosslinkable functional groups.

35. A process for the manufacture of a LC display, which process comprises the steps of:

- a) preparing microcups by first coating a layer of thermoplastic or thermoset precursor on a conductor film followed by embossing the thermoplastic or thermoset precursor layer with a male mold or by imagewise exposing the thermoset precursor layer and removing the unexposed areas;
- b) filling in the thus-formed array of microcups with LC;
- c) sealing the microcups; and
- d) laminating the sealed array of LC cells with a second conductor film preferably pre-coated with an adhesive layer.

36. The process of Claim 35 wherein the sealed array of LC cells are laminated with a second conductor film pre-coated with an adhesive layer.

37. The process of Claim 35 wherein the adhesive layer is hardenable or crosslinkable by heat, moisture or radiation, and is cured during or after lamination.

38. A process for the manufacture of a multi-color LC display, which process comprises the steps of:

- a) preparing microcups by first coating a layer of thermoplastic or thermoset precursor on a conductor film followed by embossing the thermoplastic or thermoset precursor layer with a male mode or by imagewise exposing the thermoset precursor layer and removing the unexposed areas;
- b) laminating the thus formed array of microcups with a layer of positive photoresist;
- c) imagewise exposing the positive photoresist to selectively open the microcups in a predetermined area;
- d) filling in the opened microcups with LC with guest dye(s) of the first color;
- e) sealing the microcups to form closed LC with guest dye(s) of the first color;

- f) repeating Steps c) to e), if necessary, in different areas to generate groups of microcups containing LC fluid of different colors;
- g) removing residual positive photoresist, if any; and
- h) laminating the sealed array of LC cells with a second transparent conductor film precoated with an adhesive layer.

39. The process of Claim 35 wherein the sealing of the microcups is accomplished by filling the microcups with LC and a dispersion of thermoplastic or thermoset precursor composition which has a specific gravity lower than that of the LC, followed by hardening the thermoset precursor composition during or after it phase separates and forms a supernatant layer above the LC.

40. The process of Claim 39 wherein the sealing of the microcups is accomplished by filling the microcups with LC and guest dye(s).

41. The process of Claim 38 wherein the sealing of the microcups is accomplished by filling the microcups with LC and a dispersion of thermoplastic or thermoset precursor composition which has a specific gravity lower than that of the LC, followed by hardening the thermoplastic or thermoset precursor composition during or after it phase separates and forms a supernatant layer above the LC.

42. The process of Claim 41 wherein the sealing of the microcups is accomplished by filling the microcups with LC and guest dye(s).

43. The process of Claim 35 wherein the sealing of the filled microcups is accomplished by overcoating onto the said LC a thermoplastic or thermoset precursor composition which is at least partially immiscible with said LC and has a specific gravity lower than that of said LC, followed by hardening the said thermoplastic or thermoset precursor composition.

44. The process of Claim 38 wherein the sealing of the filled microcups is accomplished by overcoating onto the said LC a thermoplastic or thermoset precursor composition which is at least partially immiscible with said LC and has a specific

gravity lower than that of said LC, followed by hardening the said thermoplastic or thermoset precursor composition.

45. The process of Claim 35 wherein an adhesive layer is precoated on the positive photoresist and laminated onto the array of microcups.

46. The process of Claim 38 wherein an adhesive layer is precoated on the positive photoresist and laminated onto the array of microcups.

47. The process of Claim 45 wherein said adhesive is developable by the developer of the positive photoresist.

48. The process of Claim 46 wherein said adhesive is developable by the developer of the positive photoresist.

49. The process of Claim 38 wherein the color filters are laminated or coated onto the display.

50. The process of Claim 49 wherein said color filters are red, green or blue color filters.

51. The LC display of Claim 1 wherein LC is colored by a guest dye.

52. The LC display of Claim 51 wherein the guest dye color is a subtractive or additive color system.

53. The LC display of Claim 1 wherein the display comprises more than one layer of microcup array filled with liquid crystal composition.

54. The LC display of Claim 1 wherein said LC display is multi-color and wherein the color filters are laminated or coated onto the display.

55. The LC display of Claim 54 wherein said color filters are red, green, or blue color filters.

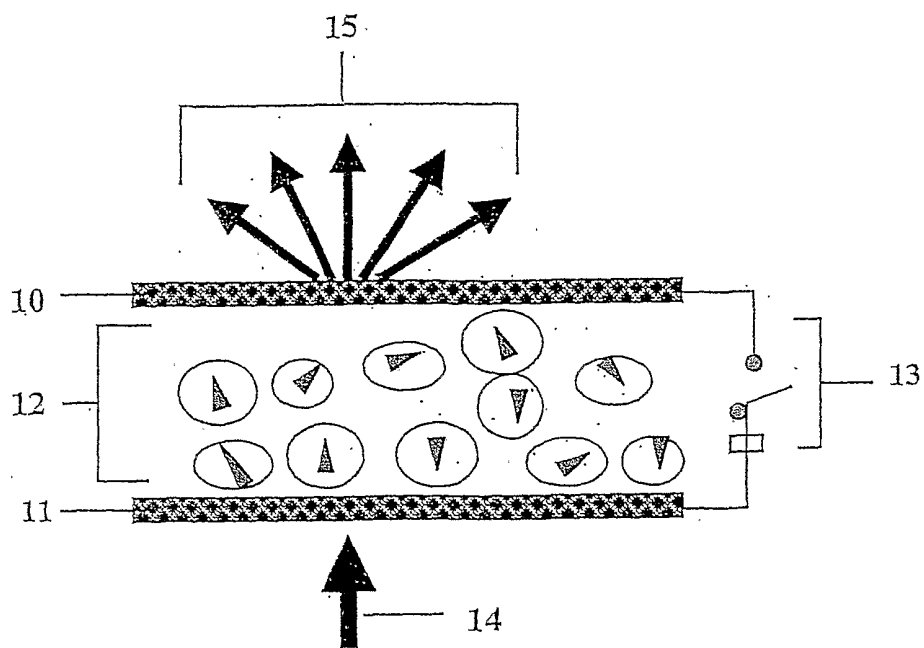

Off State
Scatters Light, White

FIG. 1a

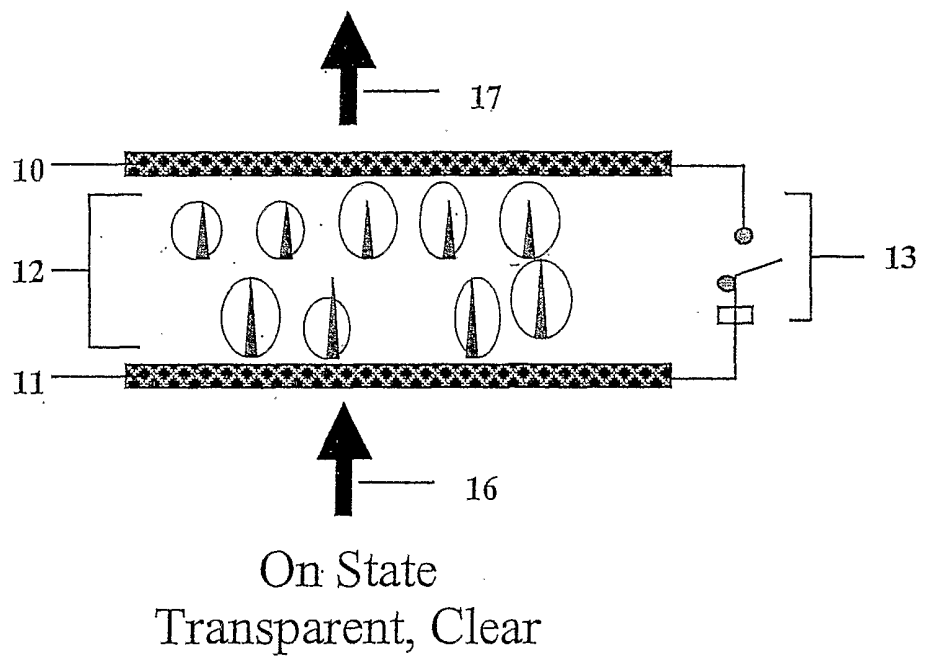

FIG. 1b

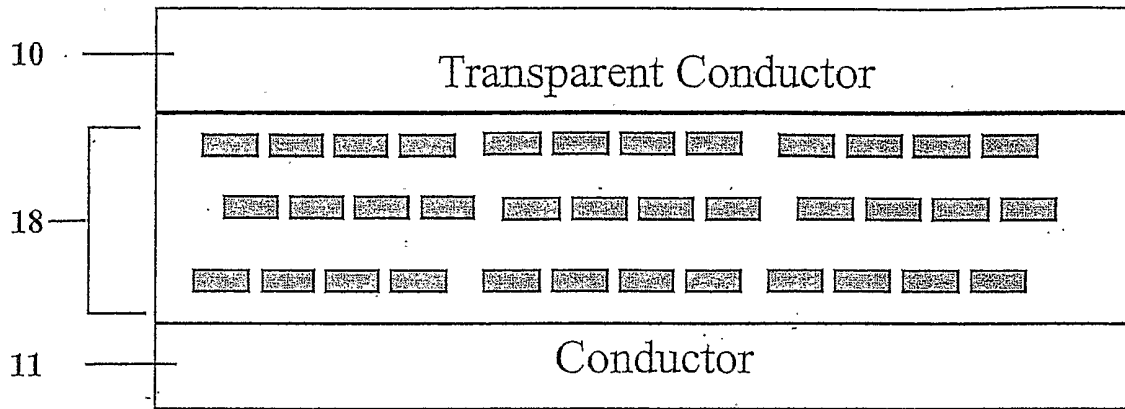

FIG. 1c

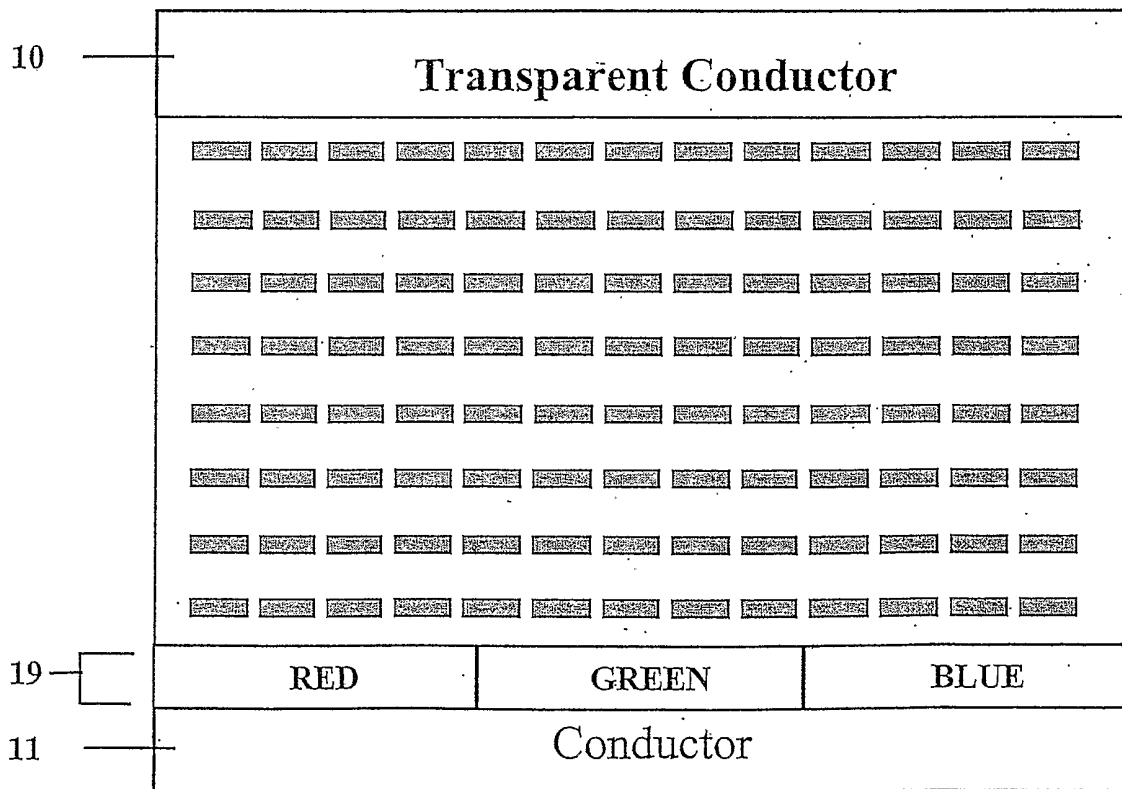

FIG. 1d

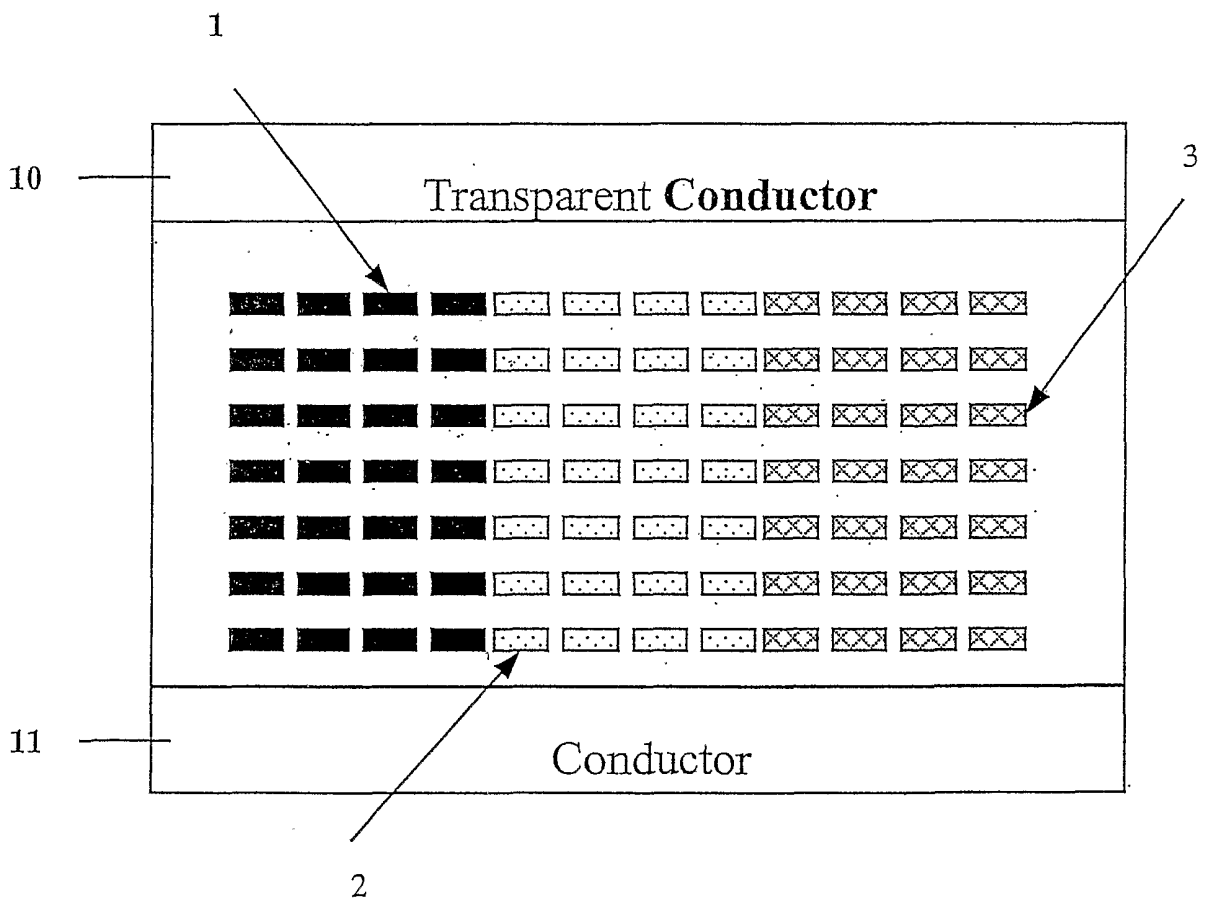

FIG. 1e

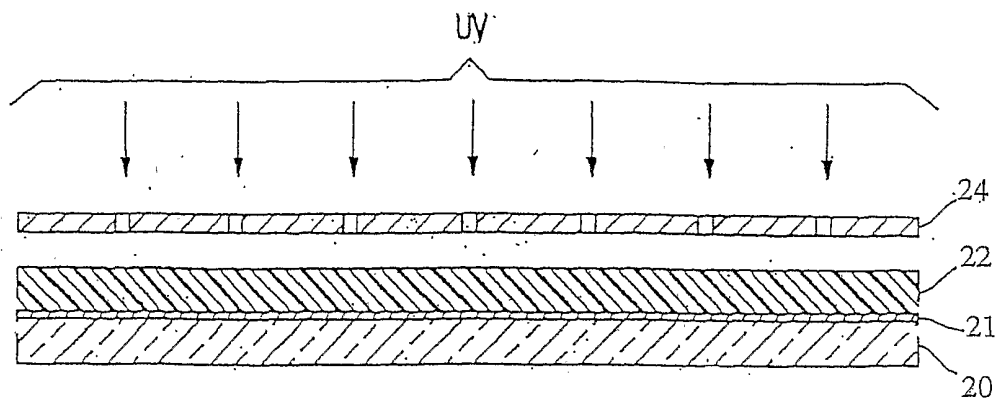

FIG. 2a

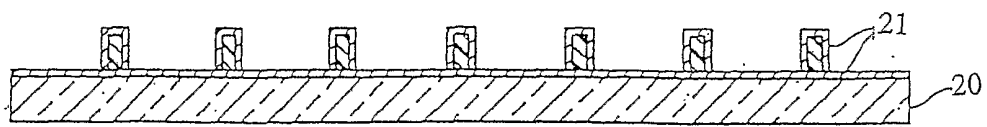

FIG. 2b

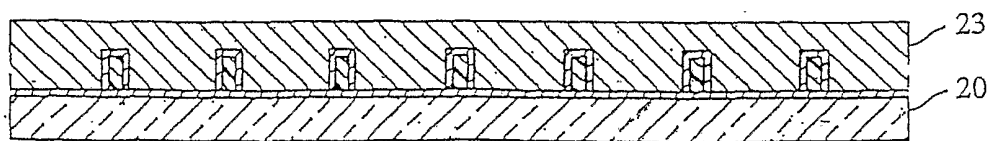

FIG. 2c

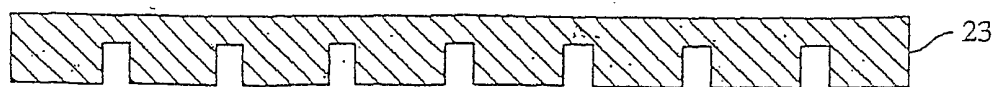

FIG. 2d

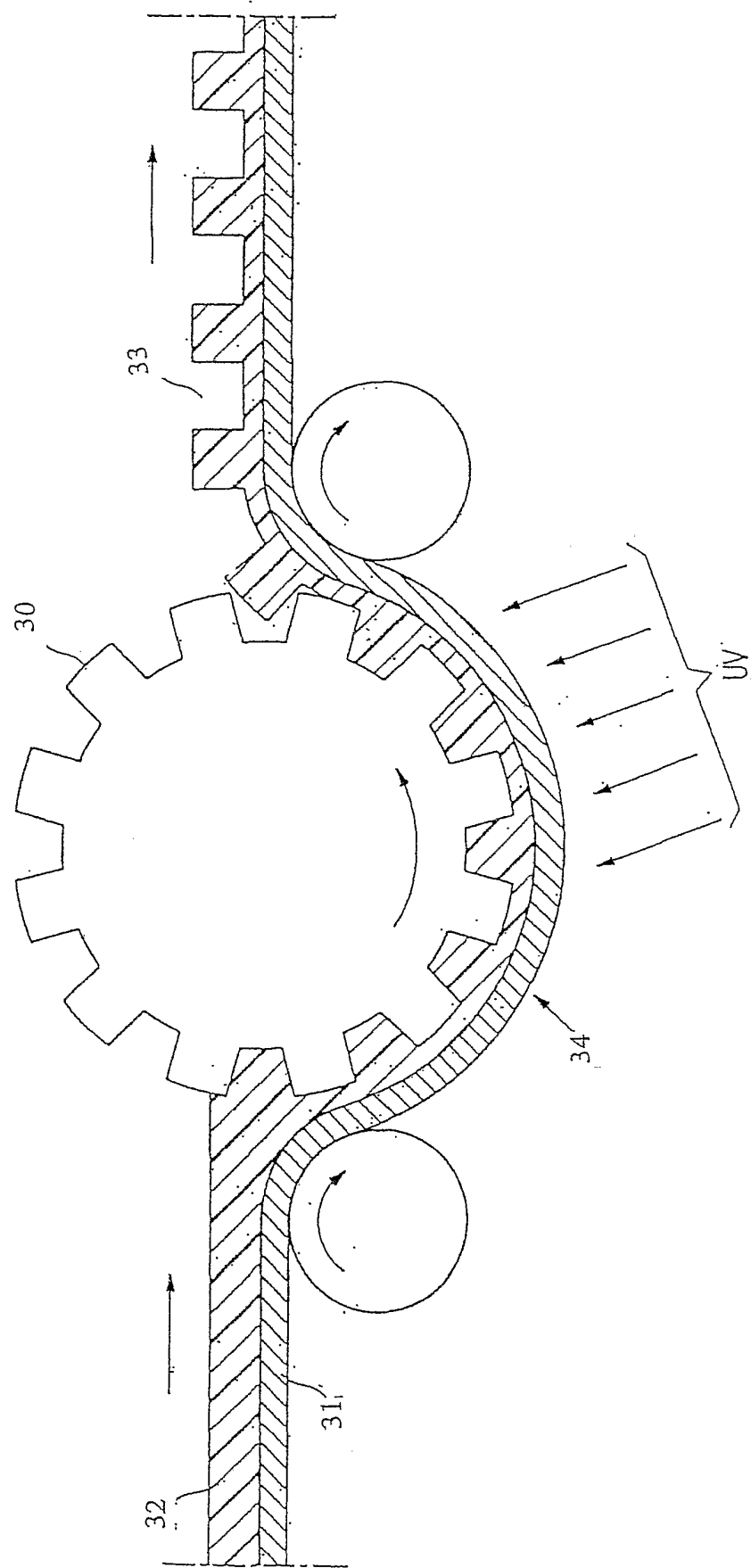

FIG. 3a

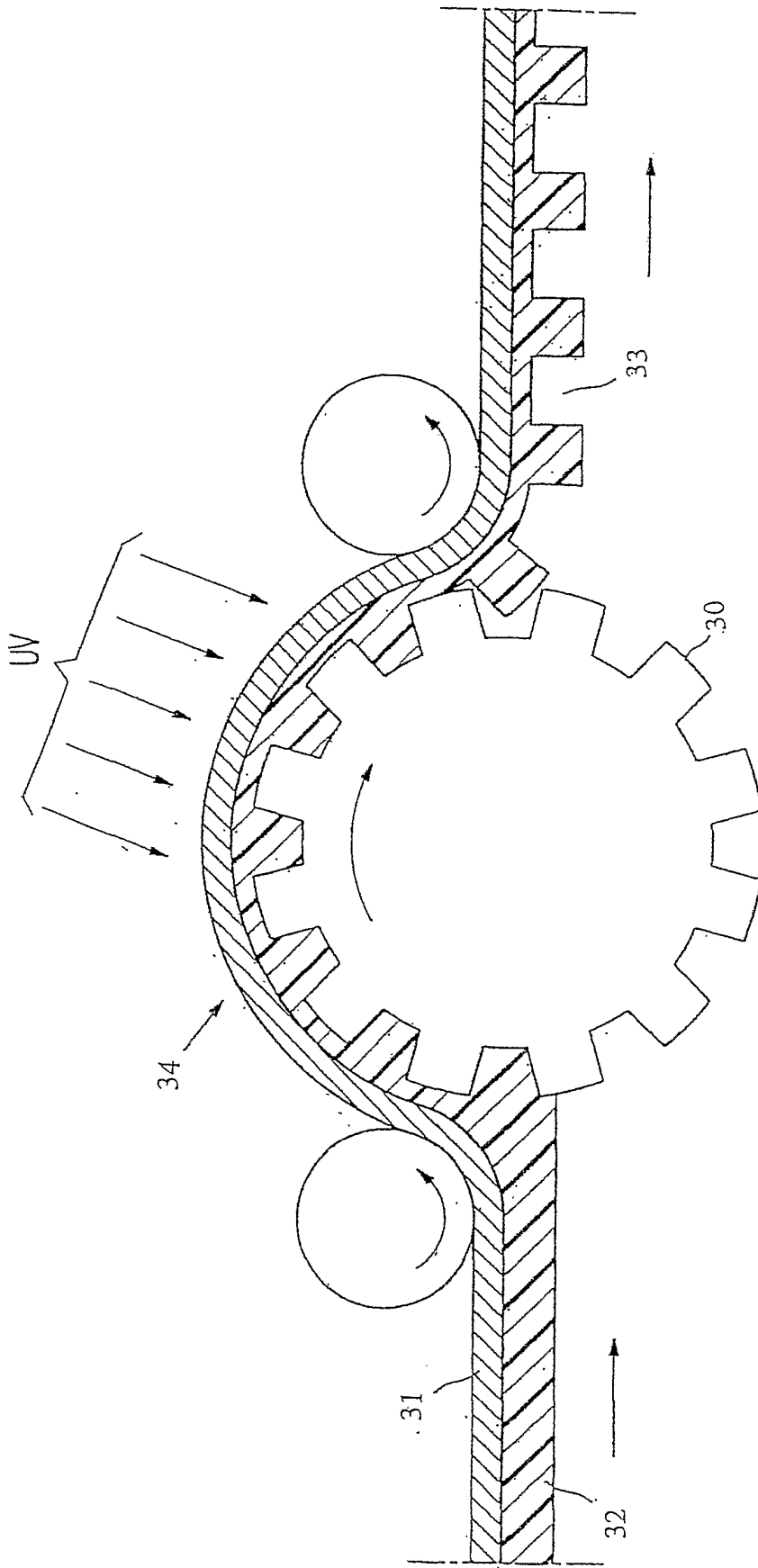

FIG. 3b

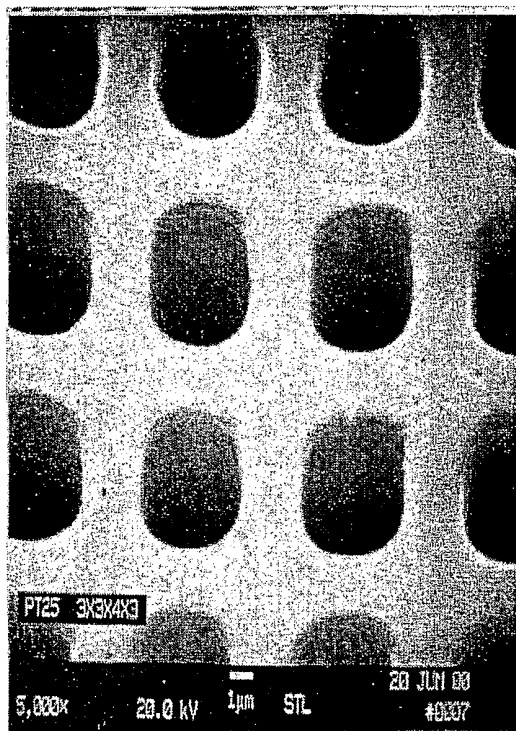

FIG. 4a

SEM Micrograph of Microcups
4.3 x 4.3 x 4.4 x 2.4 μ m (5000x)
(L x W x D x Wall)
Opening Area 41%

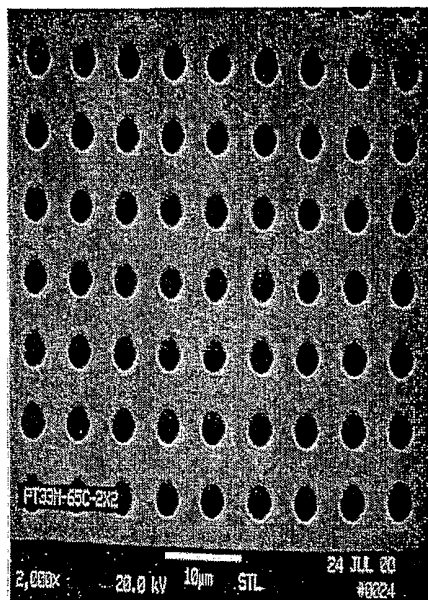

FIG. 4b

SEM Micrograph of Microcups
3.5 x 3.5 x 3.5 x 2.5 μ m (2000x)
(L x W x D x Wall)
Opening Area 34%

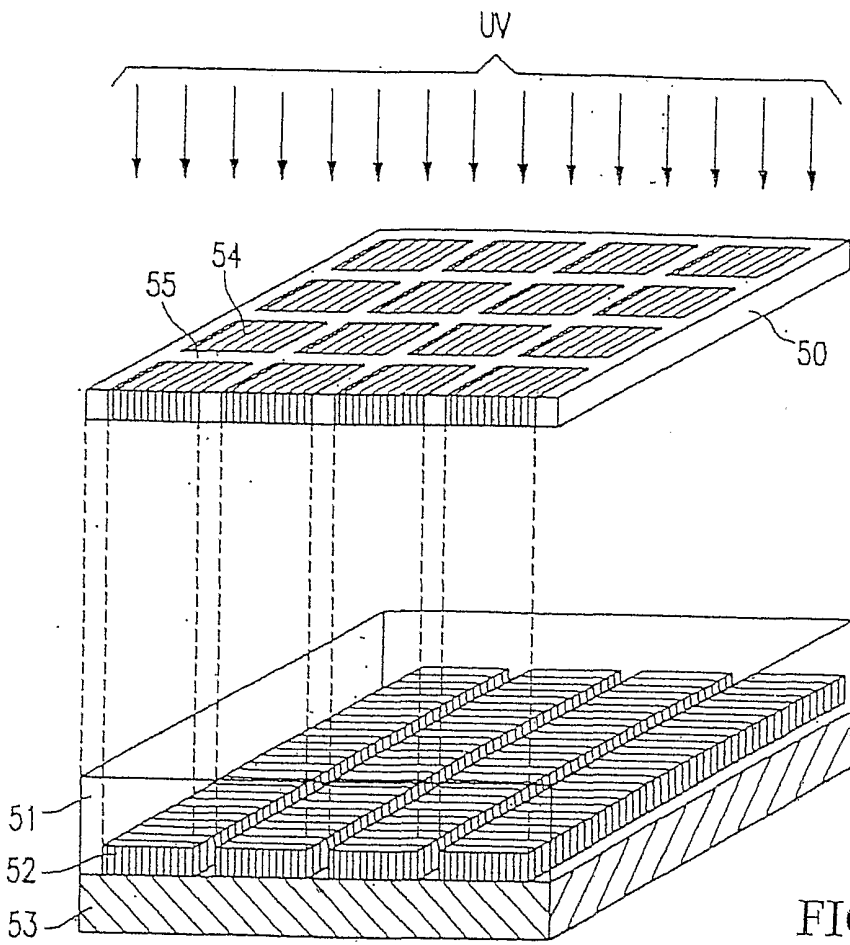

FIG. 5a1

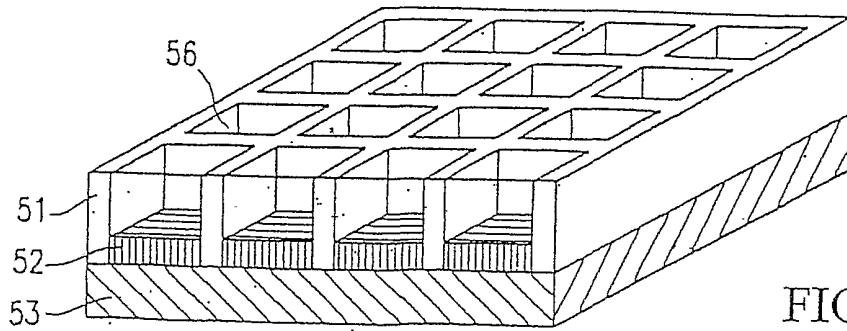
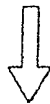

FIG. 5a2

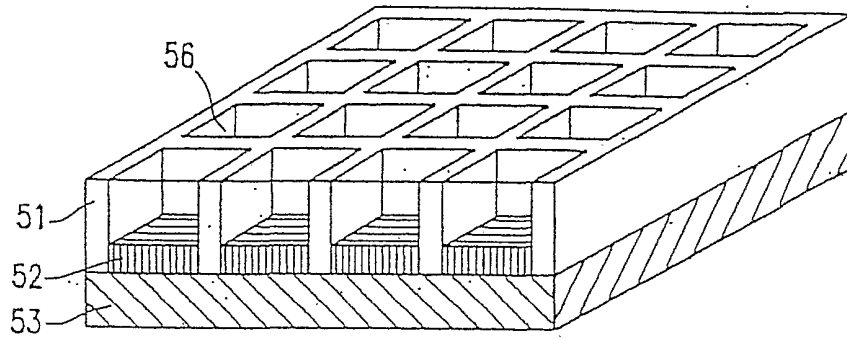

FIG. 5b2

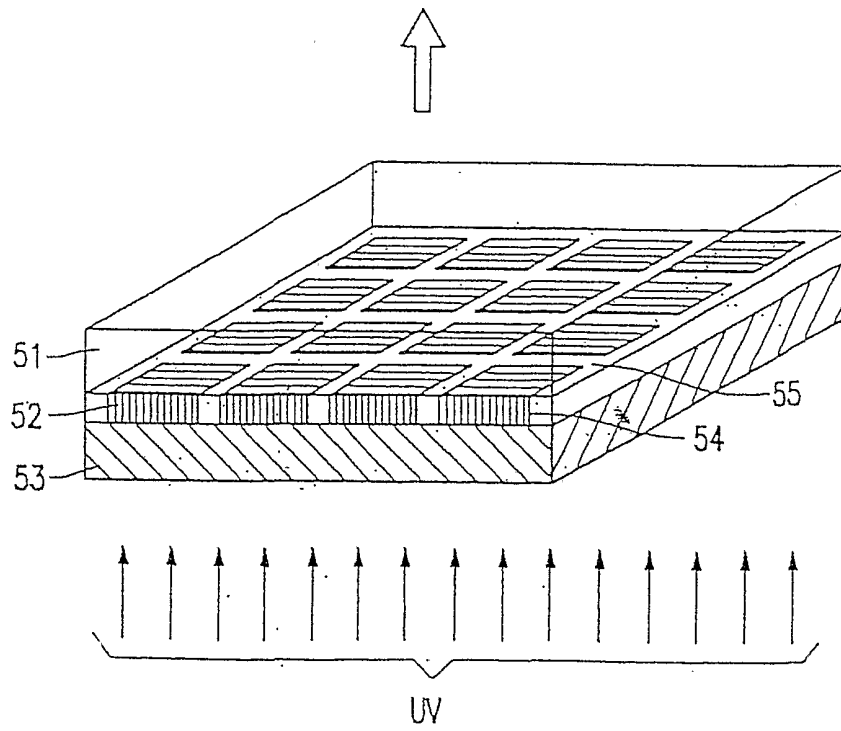

FIG. 5b1

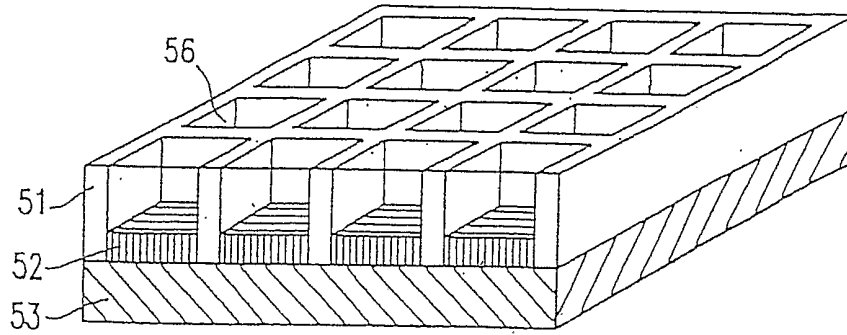

FIG. 5c2

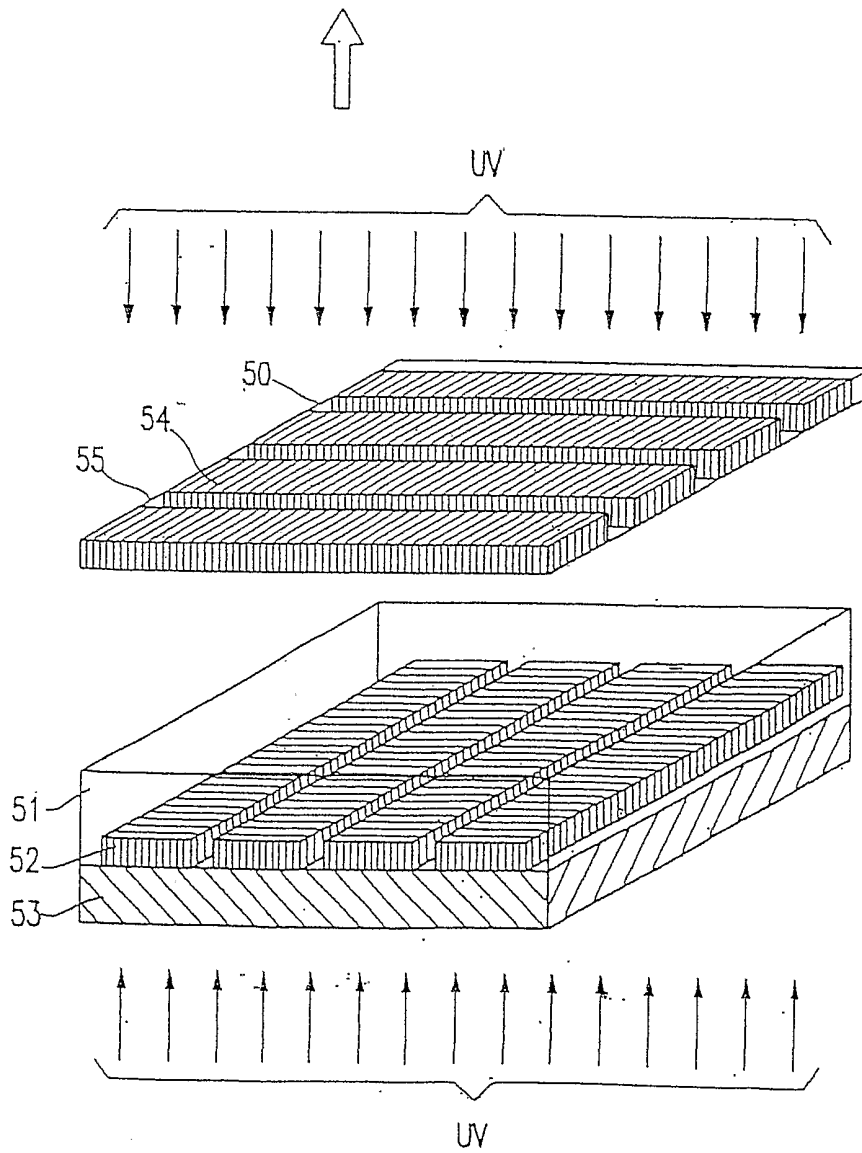

FIG. 5c1

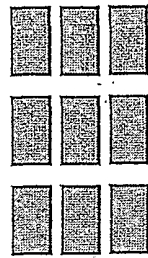

FIG. 6a

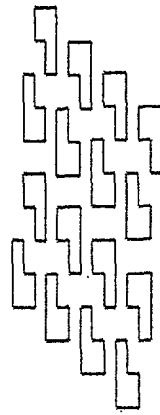

FIG. 6b

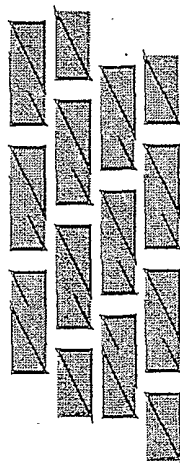

FIG. 6c

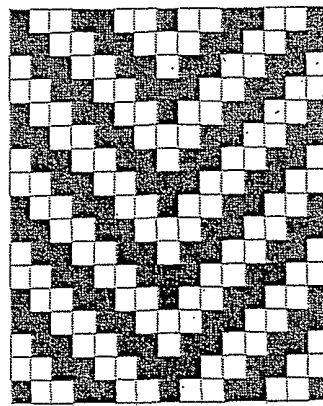

FIG. 6d

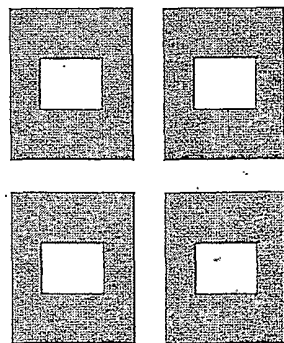

FIG. 6e

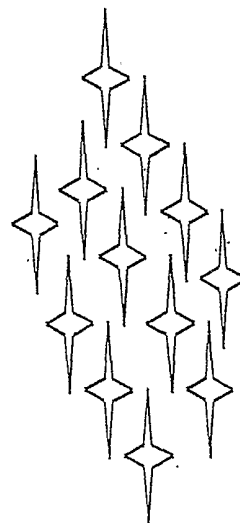

FIG. 6f

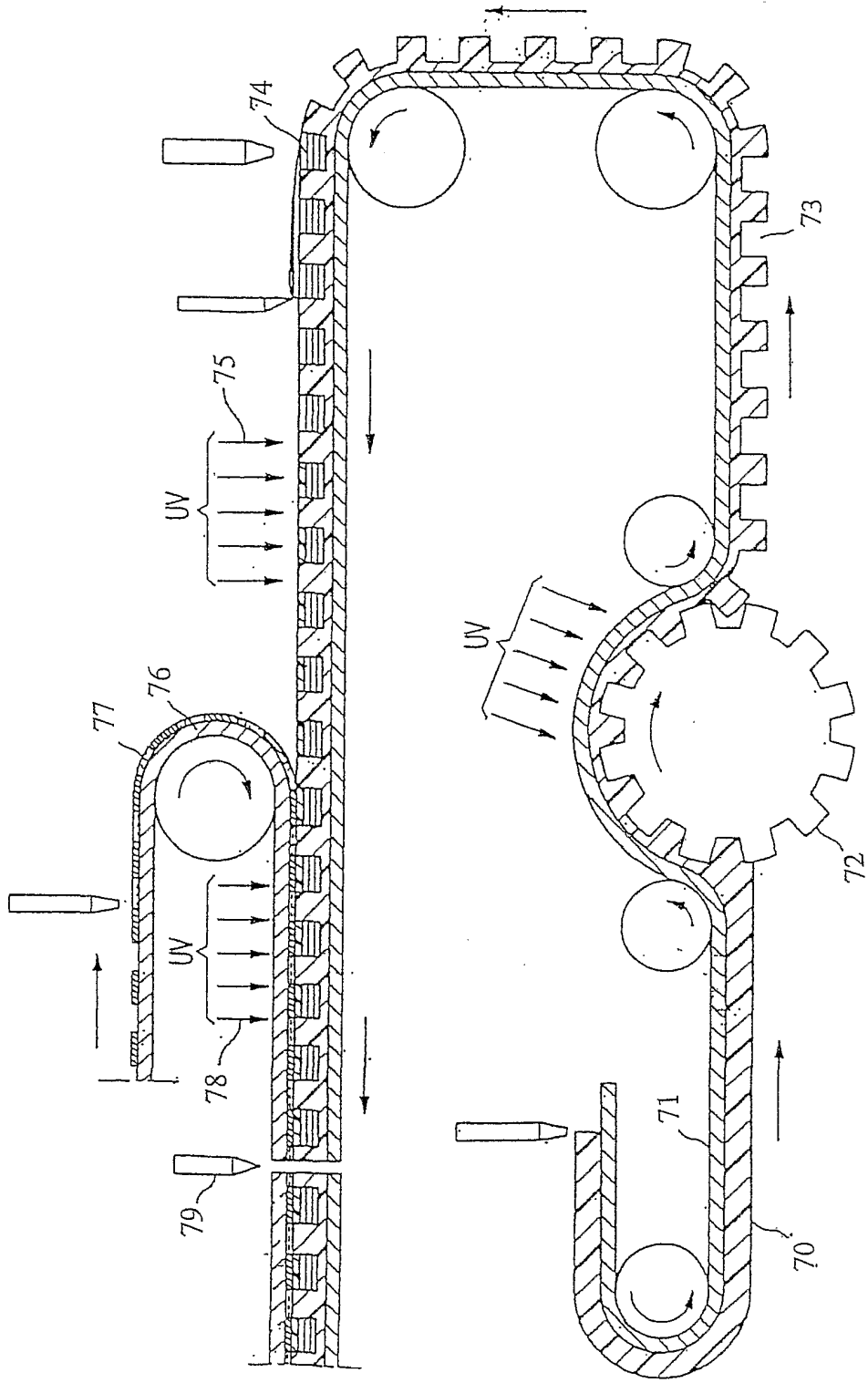

FIG. 7

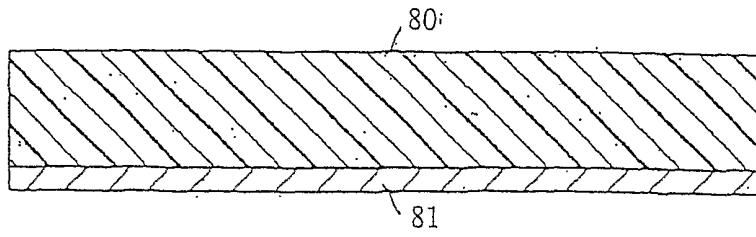

FIG. 8a

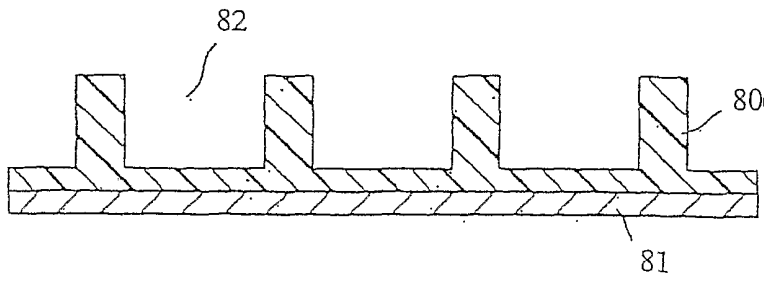

FIG. 8b

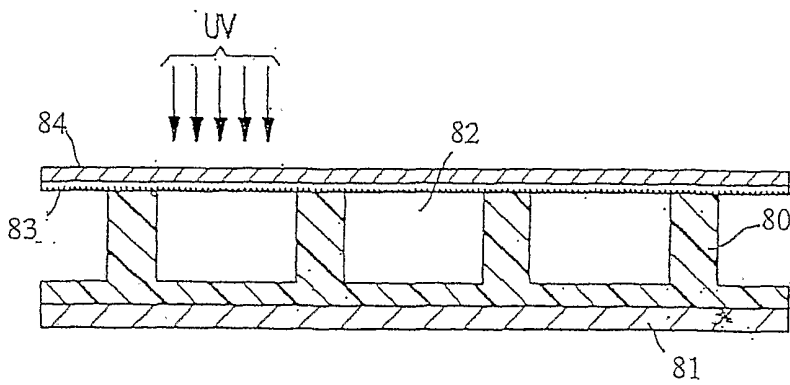

FIG. 8c

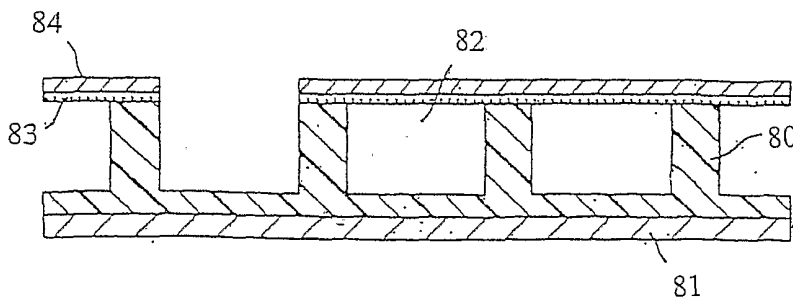

FIG. 8d

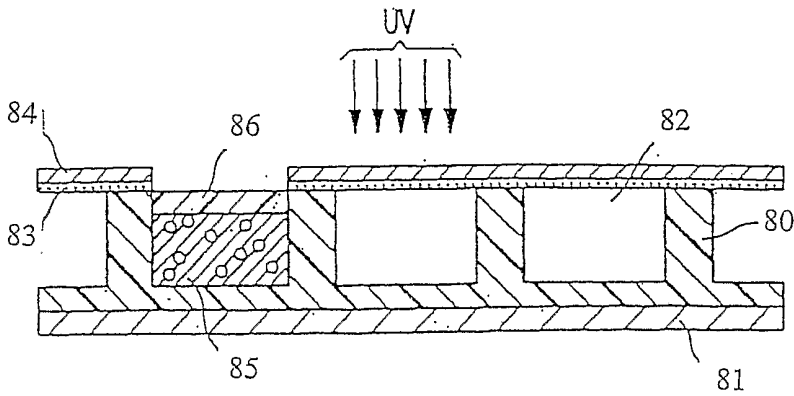

FIG. 8e

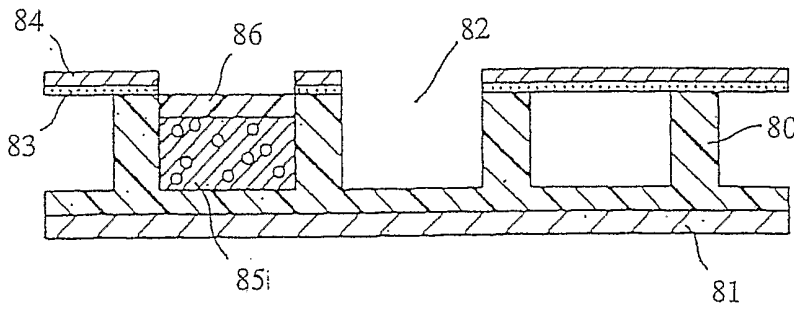

FIG. 8f

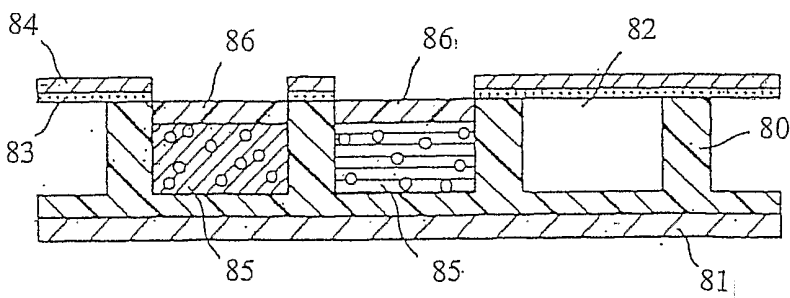

FIG. 8g

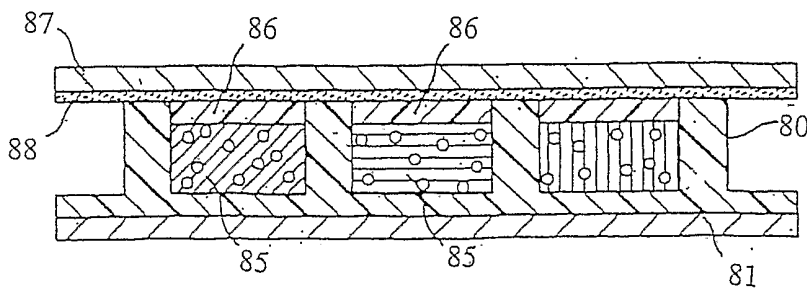

FIG. 8h

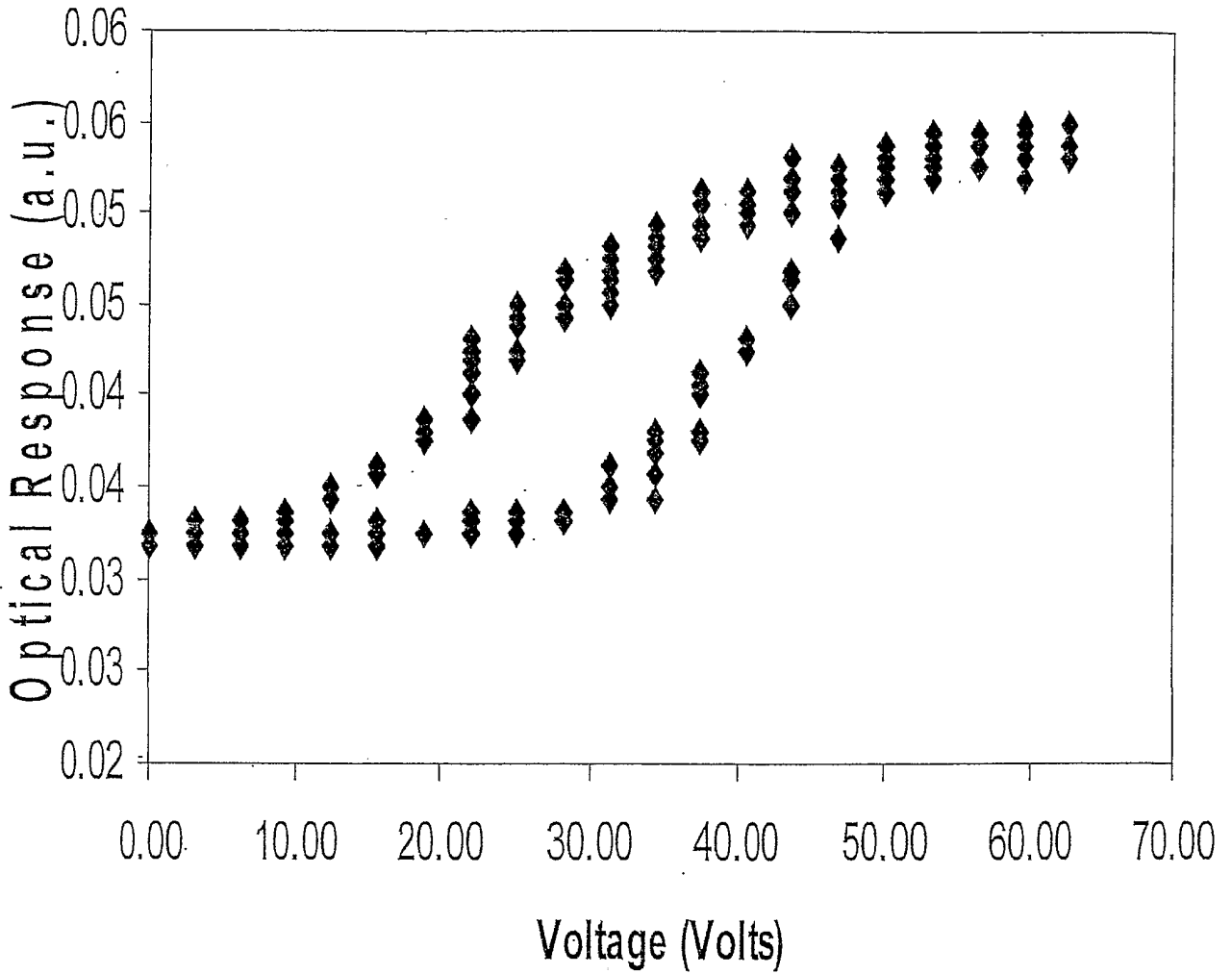

FIG. 9a

Hysteresis Curve of Conventional PDLC

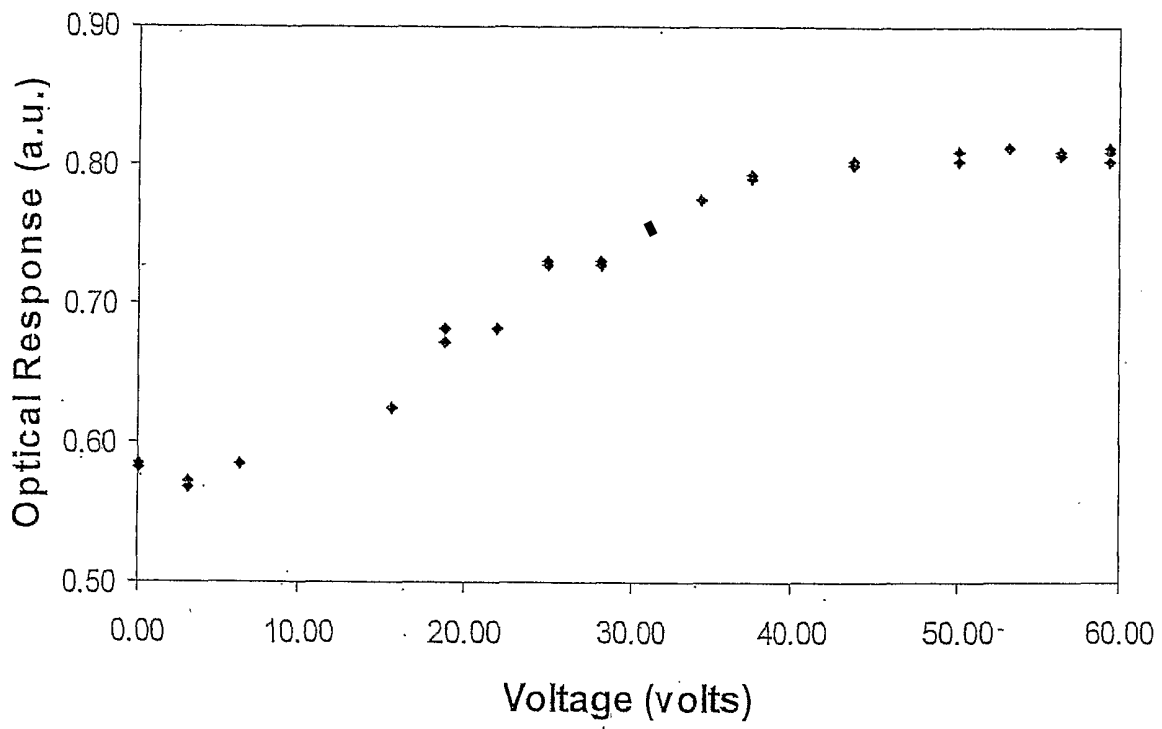

FIG. 9b

Hysteresis Curve of a LCD of the Current Invention