

No. 890,097.

PATENTED JUNE 9, 1908.

G. & M. J. ROESKEN.
SHOE AND BOOT SCRAPER.
APPLICATION FILED MAY 6, 1907.

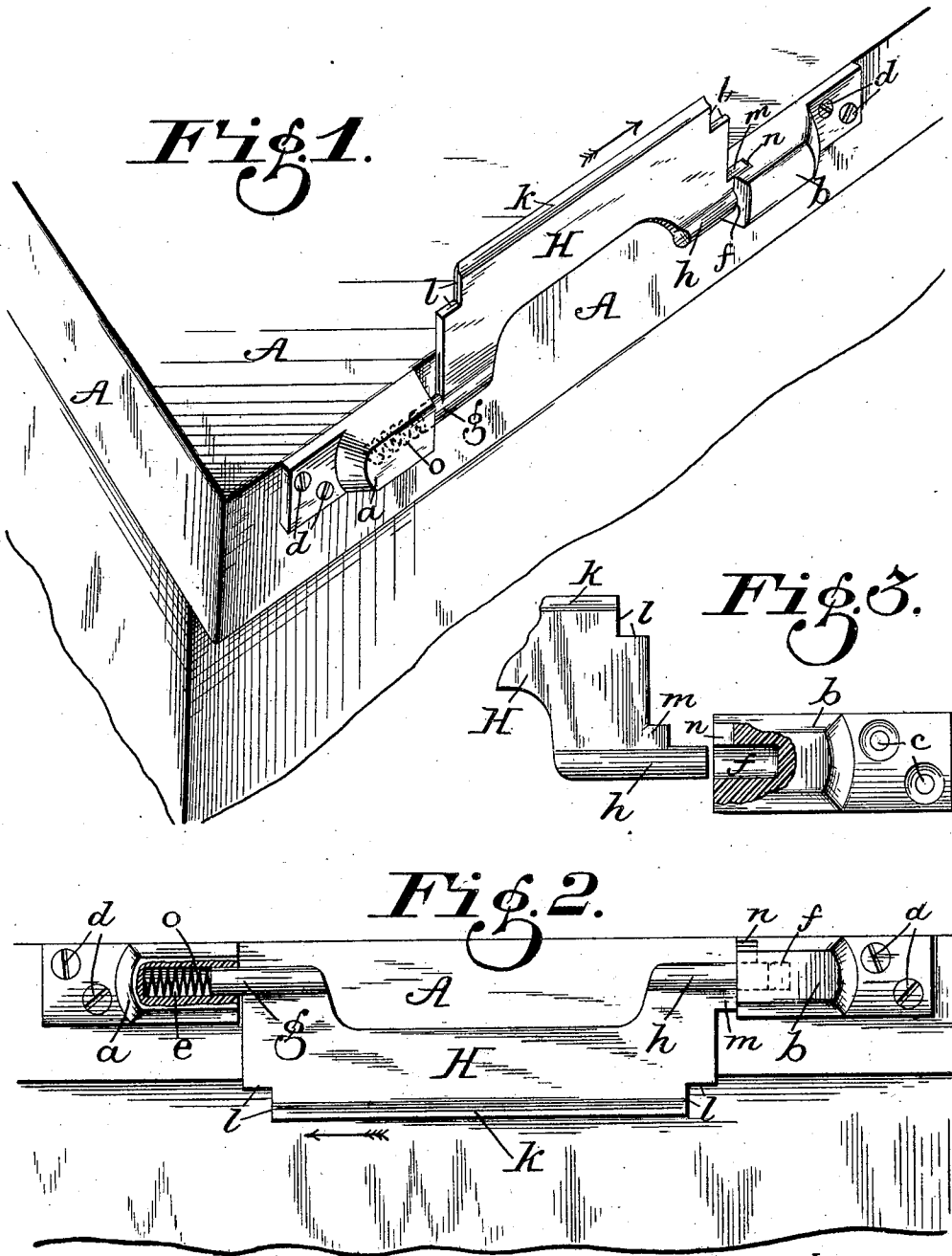

WITNESSES:

John P. Bauer.
Jas. O. Hartshorn.

INVENTORS:

George Roesteen
and Maurice J. Roesteen,
BY

Frank M. Burnham
Attorney.

UNITED STATES PATENT OFFICE.

GEORGE ROESKEN AND MAURICE J. ROESKEN, OF DAYTON, OHIO.

SHOE AND BOOT SCRAPER.

No. 890,097.

Specification of Letters Patent.

Patented June 9, 1908.

Application filed May 6, 1907. Serial No. 372,065.

To all whom it may concern:

Be it known that we, GEORGE ROESKEN and MAURICE J. ROESKEN, citizens of the United States of America, residing at Dayton, in the county of Montgomery and State of Ohio, have invented certain new and useful Improvements in Shoe and Boot Scrapers; and we do hereby declare the following to be a full, clear, and exact description of the invention, such as will enable others skilled in the art to which it appertains to make and use the same, reference being had to the accompanying drawings, and to the letters and figures of reference marked thereon, which form a part of this specification.

Our invention relates to improvements in shoe and boot scrapers—but more directly and specifically to that class of scrapers and cleaners in which all projecting parts, such as the scraper-blade or cleaner, may be readily thrown out of danger of injury to children or adults, when not in use and back to its normal position; and yet these parts may be readily and quickly thrown back again in operative position, *ad libitum*.

Some of the principal objects and purposes of our said invention, consist in constructing a device of the class and character just referred to, which will be simple in construction; composed of few parts; inexpensive in cost of manufacture; and effective in its results generally.

Our invention consists essentially, referring briefly and in general terms to the construction of the device covering the same;—of the peculiarly formed scraper-blade or cleaner; and detent; the bearing-blocks, one of which is provided with a slot or recess; and the spring or reacting member; and other and minor details of construction; and the very peculiar and novel arrangement, construction, and combination of these several parts, as will be hereinafter more elaborately and specifically referred to in detail, and set forth in the subjoined claims in accordance with the statutes in such cases made and provided therefor.

Referring to the accompanying drawing constituting a formal part of this specification, and wherein the same letters of reference are employed to indicate or point out the same parts wherever occurring throughout the several views;—

Figure 1, is a perspective view showing the

practical application of our invention when 55
our shoe and boot scraper is attached to a porch-step,—with the blade raised in operative position:—Fig. 2, is a side elevation of the device as shown in Fig. 1,—with the blade down when in an inoperative position; 60
and Fig. 3, is a detail view partially broken away and in section:—of one end of the scraper-blade and one of the bearing-blocks;—so as to show the detent and slot or recess which receives the same. 65

In describing our said invention specifically, and referring in detail to the various mechanical parts or elements of construction, of our shoe and boot scraper, as shown throughout the several views of the drawing, 70
and indicated by means of the letters of reference as aforesaid; *a* and *b* designate the respective bearing-blocks provided with eyes *c*, by which they are firmly and securely attached or connected at *d* by screws or otherwise, to porch-step A,—(or other like suitable and convenient member)—as shown. 75
The body-portion of each of said bearing-blocks is provided with a socket *e* and *f* adapted to receive the trunnions *g* and *h* respectively, formed one on each end of the scraper-blade H. One of said blocks has a vertical end slot or recess *n* communicating with the socket *f*, and the scraper-blade has a lug or detent *m* which is pressed into said 85
slot when the blade is in an upright position, by a spring or reacting member *o* bearing against the bottom of the socket *e* and the end of trunnion *g*. The blade is formed at the top with a scraping edge *k* to scrape the 90
bottom of the shoe, and at the upper corners with angular edges *l* to scrape the edges of the sole and heel. Now when it is desired to throw said scraper-blade again down or lower it back to its inoperative position (see 95
Fig. 2;) and from its operative position (see Fig. 1,) as just described, all that is necessary is to simply move or push with the foot or otherwise said scraper-blade longitudinally in an opposite direction—(see the ar- 100
rows);—so that its trunnion *g* will now force said spring in its socket, thus causing it to be contracted or compressed sufficiently to allow of said blade being turned until said detent is moved out of said slot or recess and 105
rests against the outside of bearing-block *b*, and the parts are all in the position shown in Fig. 2: when said projecting scraper-blade

will rest down below the top of step A, where it will be out of the way of all danger from accidents or otherwise to children or adults.

All the parts of our device are intended to be constructed out of suitable metal.

We claim as our invention:—

1. In a shoe and boot scraper, the combination of the bearing-blocks adapted to be connected to a step, and each provided with a socket; the scraper-blade movably mounted by means of trunnions in the sockets of said bearing-blocks; so that said scraper-blade will rest above said step when in operative position, and below said step when in an inoperative position; all substantially in the manner and for the purposes described.

2. The combination in a shoe and boot scraper, of the bearing-blocks, each provided with a socket; an actuating means located in the socket of one of said bearing-blocks; one of said bearing-blocks being provided with a recess; a scraper-blade provided with trunnions, one of said trunnions adapted to bear against the actuating means in said socket of one of the bearing-blocks when said blade is raised; and a lug on one of the trunnions adapted to engage said recess, when said scraper-blade is raised, and to be disengaged from said recess when said scraper-blade is down; all substantially as set forth.

3. The herein described shoe and boot scraper having bearing blocks, each of which is provided with a socket, one of which is

provided with a slot or recess; a resilient-member adapted to be inserted and rest within the socket of one of said bearing-blocks; a scraper-blade provided with trunnions one of which is adapted to rest in and bear against said resilient-member, while the other or opposite trunnion is adapted to rest in said socket of the opposite bearing-block and is provided with a detent adapted to engage and rest within said slot, said scraper-blade being further provided with a straight-edged scraper, and also angular-edged scrapers; substantially as set forth.

4. A shoe and boot scraper comprising the following elements, to wit:—a bearing-block provided with a straight socket; a bearing block provided with a socket and having a slot in its inner end; a spring adapted to rest in the straight socket; and a scraper-blade provided with trunnions, one of which is adapted to be actuated by said spring, while the other trunnion is provided with a detent adapted to rest in said slot when in its operative position; substantially in the manner and for the purposes set forth.

In testimony whereof, we affix our signatures, in presence of two witnesses.

GEORGE ROESKEN.
MAURICE J. ROESKEN.

Witnesses:

JOHN P. BAUER,
AUGUST TOOHEY.