

J. G. BAKER.
GRINDING MILL.

No. 104,537.

Patented June 21, 1870.

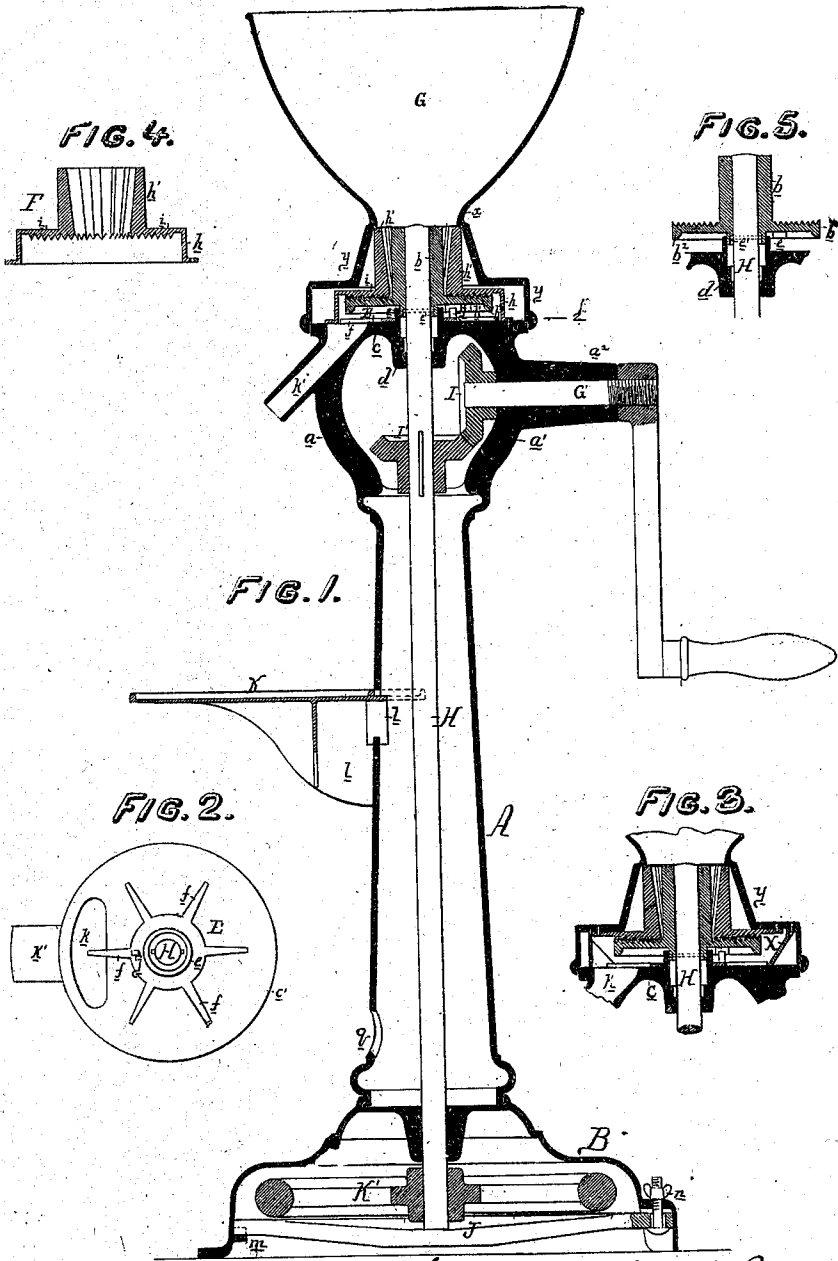

WITNESSES { *Wm. A. Steel,*
John Parker

John G. Baker,
by his attys.
Howan and others,

United States Patent Office.

JOHN GULICK BAKER, OF PHILADELPHIA, PENNSYLVANIA.

Letters Patent No. 104,537, dated June 21, 1870.

IMPROVEMENT IN GRINDING-MILLS.

The Schedule referred to in these Letters Patent and making part of the same.

I, JOHN GULICK BAKER, of Philadelphia, county of Philadelphia, State of Pennsylvania, have invented an Improved Grinding-Mill, of which the following is a specification.

Nature and Object of the Invention.

My invention consists of a grinding-mill, especially adapted for use by grocers, &c.; owing to the simplicity of its construction, portable character, cheapness and steadiness while in operation, my improved mill possessing many important features which are applicable to mills generally, and which are too fully described hereafter to need preliminary explanation.

Description of the Accompanying Drawing.

Figure 1 is a vertical section of my improved grinding-mill;

Figure 2, a plan view on the line 1-2, fig. 1, showing the scraper;

Figure 3, a vertical section, illustrating a modification of part of my invention; and

Figures 4 and 5, detached sectional views of parts of the mill.

General Description.

The standard or frame of the mill consists of a hollow column, A, screwed or otherwise secured to the hollow base B, the upper end of the column consisting of an open frame, composed of two arms, *a* and *a'*, which are, in the present instance, of the curved form represented in fig. 1, but which may be modified in shape without departing from the main features of my invention, these two arms terminating in a circular face-plate, *c*, to which is secured the shell F of the mill.

This shell consists of the lower annular portion *h*, the hollow projection *k*, having a cone-shaped interior, and the horizontal portion *i*, on the under side of which are formed fine grinding-teeth.

The shell of the mill, best observed in the detached view, Figure 5, consists of the central hub *b*, the disk *b'* having fine grinding-teeth on its upper surface, and having a strengthening-rib, *b''*, below.

The upper bearing of the shaft H is in a hub, *d*, projecting downward from the face-plate *c*, and above the face-plate is an annular projection, *e*, concentric with the shaft, and penetrated by an annular projection, *e'*, on the under side of the face-plate. Not only is ground matter thus prevented from entering the bearing, but a permanent receptacle for oil is afforded, as will be readily understood on reference to fig. 5.

On the face-plate *c* rests the scraper or distributor E, fig. 2, which consists of any desired number of arms, *f*, projecting from a ring, so adapted to the above-mentioned annular projection *e* that it can be

turned freely thereon by a projection on the under side of the lever coming in contact with a projection, *j*, on the scraper.

There is in the face-plate *c* an elongated hole, *k*, partly across which the arms of the scraper must revolve, and which communicates with an inclined spout, *k'*.

The hopper G consists of a light disk-shaped casting, having at *x* a neck, so constructed that it will, in the interior, be in contact with the upper edge of the portion *h* of the bur, thereby giving a proper direction to the material to be ground, the base *y* of the hopper being so formed as to inclose the shell of the mill, and to rest on the edge of the face-plate.

Motion is communicated to the shaft H by means of a handled shaft, G', which revolves in a projection, *a''*, on the frame-work, this shaft being provided with a bevel-wheel, I, gearing into a similar wheel, Y, on the vertical shaft H.

The shaft G' may be, if desired, and in mills of the larger class is furnished with a driving-pulley, instead of a handle.

The shaft H turns below in the base-plate, within which it is furnished with a fly-wheel, K', the shaft resting on a lever, J, one end of which rests in a pocket, *m*, inside the base-plate, the other end being supported by a bolt and thumb-nut, *n*, as clearly shown in fig. 1.

The lever J is dished in the middle, so as to form a receptacle for such oil as may drop from the lower bearing of the shaft H, the supply of oil in the dished lever thus serving as a constant lubricant for the lower end of the said shaft H.

K is a horizontal plate, fitted snugly to the column, and connected thereto by means of a lip, *l*, which projects through a slot in the column, the under side of the lip being recessed, so as to embrace the lower edge of the slot, a flange, *l'*, below the plate, bearing against the column, and serving to steady and maintain the plate in a horizontal position. It will be seen that this plate can be readily detached after slightly elevating it, and that no expensive fastenings are used for securing it to the column.

There is in the column an opening, *g*, through which the lower bearing of the vertical shaft H can be readily oiled.

In the modification illustrated in fig. 3, the bur is not bolted to the face-plate *c* of the column, but to the under side of the horizontal portion of the hopper's base, the annular portion *h* of the shell being thus dispensed with.

In order that the material may be retained within range of the scraper, I employ in this modification an inclined shield, X, which may also be secured to the hopper.

The coffee or other material to be ground is placed in the hopper, and is directed to the space between the portion *k* of the stationary shell and the cylindrical portion *b* of the revolving bur, the interior of the shell and exterior of the bur being here provided with coarse crushing-teeth. This space becomes narrower as it approaches the lower horizontal grinding-surface, and, hence, the latter has to act on material reduced to a proper crushed condition.

As the ground material leaves the lower grinding-surfaces, it falls on the face-plate, and is directed, by the scraper *E*, into the spout *k*, from which it falls into any suitable vessel placed on the plate *K*.

The main object of my invention has been to provide grocers and others with a cheap and effective portable mill for grinding coffee, &c., although there are features which could be applied with advantage to mills of a large class. Among these features may be mentioned that of arranging the fly-wheel of the bur's shaft horizontally and near the ground, and inclosing the fly-wheel in the base of a column which incloses the shaft and supports the shell, bur, hopper, and driving-gear. It will be evident that, by this arrangement, steadiness and stability, as well as general compactness of parts, are insured, and economy, as regards construction, attained.

Ample opportunities are afforded for the detachment and replacing of the same parts. In removing the hopper, for instance, access is at once had to the shell and bur, and both of these can be readily removed and replaced.

Claims.

1. A grinding-mill, supported on a column or frame, in the base of which is a horizontal fly or balance-wheel on a shaft secured to the bur or grinder, all substantially as set forth.

2. The column *A*, having a flat face, *c*, at the top, in combination with a bur, *F*, secured to the column above the face *c*, as described.

3. The combination of the vertical shaft *H*, recessed face-plate *c*, and bur, with its annular projection *e* extending downward into the said recess.

4. The combination of the said face-plate *c*, scraper *E*, revolving in contact with the face-plate, and spout *k*.

5. The combination of the frame or column *A* of a grinding-mill, and a plate or shelf, *K*, arranged in respect to the discharging-spout *K*, substantially as described.

6. The lever-*J*, for supporting the shaft *J*, dished, as described, in combination with devices, substantially as set forth, for elevating and depressing the said lever.

In testimony whereof I have signed my name to this specification in the presence of two subscribing witnesses.

JOHN GULICK BAKER.

Witnesses:

J. M. COLGAN,
LOUIS BOSWELL.