

Sept. 27, 1966

D. C. BEATTY

3,275,946

SELF-REGULATING COMPRESSION AMPLIFIER

Filed Nov. 6, 1963

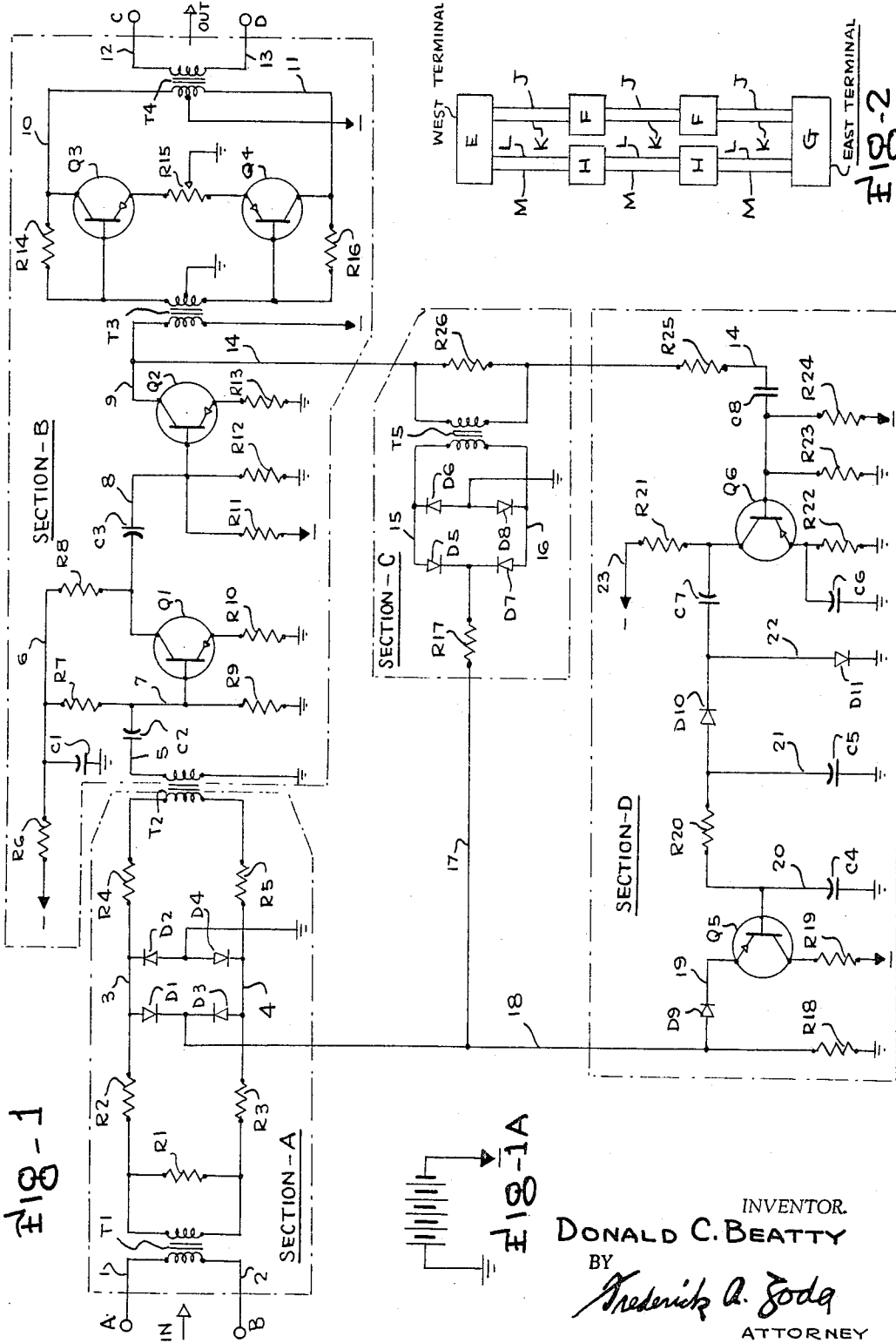

INVENTOR
DONALD C. BEATTY
 BY
Frederick A. Joda
 ATTORNEY

1

3,275,946

SELF-REGULATING COMPRESSION AMPLIFIER

Donald C. Beatty, 2800 Overhill Road, Birmingham, Ala.

Filed Nov. 6, 1963, Ser. No. 321,783

7 Claims. (Cl. 330-141)

This application is related to my copending application, Serial No. 129,211, filed 2 August 1961, now Patent No. 3,182,137.

In voice frequency transmission systems, the need has long existed for an efficient and automatic means to compensate for system degradation resulting primarily from temperature and other climatic changes which occur in a continuous and cyclic-like manner. Signal level variations from such changes are particularly noticeable over systems having long metallic circuit conductors.

The magnitude of impedance variations in a communication system is partially dependent upon the physical circuit components. This includes, among other things, the size and type of conductors (open wire or sheathed cable), type of insulators and air-spacing between their supporting structures. By way of illustration, it is known that a change in resistance value of approximately five (5) percent in such conductors will result in a temperature variation of 22° F. from the standard 55° F. normally used when computing characteristics of transmission circuits. By extrapolation, it can be readily understood that total line attenuation over moderate length wire circuits will result in a signal impulse loss of at least 30 db. It is obvious, therefore, that satisfactory signal energy transmission cannot be maintained within the aid of suitable means to compensate for such variations.

Various kinds of line facilities and apparatus have been utilized to minimize signal degradation resulting from climatic changes. In some instances, it has been found necessary to utilize 4-wire circuits in order to maintain signal strength at a satisfactory level. In such an arrangement, a separate pair of conductors is used for transmission in each direction. However, in order to hold the transmitted intelligence at a satisfactory signal level, it is common practice to install one-way amplifiers or "repeaters" at regular intervals in each circuit pair of the 4-wire system. Also, long-wire circuits are usually broken up into circuit units or sections of moderate length in order to better control the signal amplitude over the system as a whole. One of the repeaters in each circuit section is usually a master regulating repeater for the section. The device is a complex electro-mechanical apparatus which employs the principle of the balanced bridge. A portion of the latter, known as "pilot wire," functions as one arm of the bridge. To be effective, the pilot wire must extend through the same length of the section as the circuit to be regulated. For this and other undesirable characteristics, such an approach towards signal level regulation is inefficient, complex, costly, and difficult to maintain operative.

My present invention, a novel type of self-regulating compression amplifier, resolves the above and other deficiencies normally associated with signal energy regulation in communication circuits. It is a general object of the invention therefore to improve the operation of voice frequency transmission systems, particularly as regards the maintenance of satisfactory levels of signal intelligence transmitted over such systems.

To this end, the invention is arranged to be connectable to a communication circuit, and includes a means to receive input signal energy, and to automatically amplify or reduce such energy and retransmit it into other communication circuits.

Another object of the invention is to render a device capable of accepting the input of voice frequency en-

2

ergy of greater or lesser magnitude and to automatically adjust the output magnitude of such energy to a preselected value.

A further object of the invention is to provide a signal energy regulating device which has in its input section a variable loss means arranged to respond to changing levels in the magnitude of the input energy, and with said variable loss means arranged in a manner effective to continually adjust the gain to produce a substantially constant level at the output side of the signal energy regulating device.

Another object of the invention is to regulate the variable loss means by a novel voltage amplifier whose direct current output is arranged to vary in ratio to the magnitude of the input energy to the signal energy regulating device.

One object of the invention is to provide, in combination, an efficient three-stage signal energy amplifier having the last stage arranged in a push-pull configuration, and having means provided to automatically regulate its own output to a predetermined level.

A further object is to attain these desirable characteristics while providing a highly compact and maintenance-free, self-regulating compression-type amplifier; the physical dimensions of which are substantially smaller than those of other facilities heretofore devised for the same purpose.

Other objects will appear from the following description, the claims appended thereto, and wherein:

FIGURE 1 is a schematic representation of the invention;

FIGURE 1A is a schematic view of a conventional power supply useable with the invention;

FIGURE 2 is a block diagram depicting the invention in conjunction with metallic conductor circuits extending between two terminal points of a communication system.

The detailed description presented hereinafter may be more readily understood with a functional summary of the invention at this time. With that objective in view, it is pertinent to remark that the sole purpose of a communication system is to provide means for timely transmission of intelligence in a satisfactory manner. For full comprehension of the intelligence, it is desirable that it be delivered to the recipient with minimum distortion and at a relatively constant signal level. The apparatus which I have provided accomplishes this.

As previously recited, the magnitude of signal energy decreases in proportion to the length of the communication circuit. At selected points of the circuit the energy must be amplified to restore it to a satisfactory level. It is at such locations that my apparatus may be used to great advantage. Again, under other conditions, the signal energy may be of a major magnitude and a reduction thereof is desirable to prevent over-modulation, cross-talk or other objectionable characteristics. Here, too, the apparatus may be used to like advantage to reduce the excessive level to one of appropriate value.

With reference now to FIGURE 1 of the drawing, terminals A-B and C-D have been provided as input and output terminals respectively. Signal energy, of small magnitude, input to A-B will be induced into Section A by transformer T1. This energy, without initial regulation, will be induced into Section B by T2. The energy will thereupon be amplified by Q1 and Q2 and portions of it will be conducted simultaneously to R26 of Section C via leads 9-14 and to the primary of T3 via lead 9. With only minute delay the energy appears at the base of Q6 of Section D. Following amplification by Q6, rectification to negative voltage by D10, it appears at the base of Q5 as bias voltage for that transistor and Q5 begins to conduct and draw current. Emitted via the emitter of Q5 and lead 19 to D9, the resistive impedance of the latter is thus caused to be

reduced. With voltage retardation thereby minimized, the current appears at the multiple diode arrangements of Sections A and C via leads 18 and 17. A slight delay in reaching the diodes of Section C is provided by R17 as a time constant in order to enable Section A to begin functioning prior to Section C.

Flow of current through D1, D2, D3, and D4 of Section A reduces the impedance of those diodes thereby effecting a greater or lesser resistive shunt across leads 3 and 4. This shunt, functioning as a variable resistor or "volume control" across the input leads to the main amplifier, Section B, thus effectively regulates the input and consequently the output of that amplifier.

Within an inaudible few microseconds of the time the above events occur the initial input energy is induced by T3 into the Q3-Q4 circuitry, amplified thereby, and emitted via output terminals C and D. During the interim, however, Section A has become effective to regulate the input to the main amplifier, Section B. Such regulation has been arranged to be in proportion to the magnitude of the input signal energy to terminals A and B, i.e., energy of greater magnitude receives more regulation than energy of lesser value. Thus arranged, signal energy of whatever value, input to terminals A-B will be emitted via output terminals C-D at a relatively constant level. Further, the time constant of signal level regulation has been arranged to occur in a manner so as to be inaudible to the recipient of the transmitted intelligence.

It is believed apparent, from the above, that input energy of excessive magnitude will be automatically reduced to a satisfactory output level, and that input energy of less than a satisfactory value will be automatically regulated upward to the desired value.

Referring now to FIGURE 2, rectangles E and G illustrate the terminal points of a 4-conductor communications circuit, an ordinary telephone switching office for example; while the rectangles F, F, H and H represent the invention. Duplicate 2-conductor metallic circuits J-K and L-M connect the terminal points. Conductors J-K function as the transmit circuit for the West Terminal E and as the receive circuit for the East Terminal G while conductors L-M function as the transmit circuit for East Terminal G and as the receive circuit for the West Terminal E. The invention may be physically and electrically associated with the circuits J-K and L-M at appropriate intervals of the circuit path wherever it is desired to correct for signal energy loss due to system attenuation.

It is believed sufficiently obvious as not to require other special illustration that the invention shall be connected to appropriate communication circuits, and that proper electric power shall be provided.

For clarification, the description of FIGURE 1, which follows, has been sectionalized into four parts each of which contain essential components and circuitry of the principal functional areas of the invention.

SECTION A

Input variable loss means

This section of the invention, arranged as a novel-type of balanced impedance bridge, is provided to maintain an automatic regulation over the magnitude of signal energy input to the apparatus. Diodes D1, D2, D3, and D4, with associated components and circuitry, function as a variable resistor or input attenuator and respond to the changing levels in the input signal energy in proportion to the magnitude of such changes.

In considering Section A in detail, the primary winding of transformer T1 is connected with terminals A and B by leads 1 and 2 respectively. Terminals A and B serve as the input terminals to the invention and as a terminus of a communication circuit to which the apparatus may be connected. Signal energy input to terminals A and B will therefore appear in the primary winding of T1 and will be inductively passed into the secondary winding.

One terminal of the secondary winding of T1 and one terminal of the primary winding of transformer T2 are connected together by lead 3 which includes the series connected resistors R2-R4. The other terminal of the secondary winding of T1 is connected to one terminal of the primary winding of T2 by lead 4 which includes the series connected resistors R3-R5.

The multiple diode arrangement of D1, D2, D3, and D4, connected as illustrated, constitutes a shunt circuit from lead 3 to lead 4 at points between R2-R4 and R3-R5 respectively. The overall impedance value of this arrangement varies in proportion to the current flow therethrough and thus may present a greater or lesser resistive connection between leads 3 and 4. A decrease in this resistive value causes a greater retardation of input signal energy.

It will be observed that the negative terminals of D2 and D4 are connected to the common ground and the positive terminals are connected to leads 3 and 4 respectively. It will also be observed that the negative terminals of D1 and D3 are connected to leads 3 and 4 respectively and the positive terminals to lead 18. Lead 18 continues to a connection with the negative terminal of diode D9 and one terminal of resistor R18, the other terminal of which is connected to the common ground. This constitutes a ground-to-ground circuit loop over which current does not flow until such current is emitted from the negative terminal of D9. An increase of current into lead 18 causes the impedance value of diode arrangement D1, D2, D3, and D4 to vary proportionately. This novel Section A circuitry is provided, in combination, to automatically regulate the magnitude of the input signal energy effective upon the main signal energy amplifier, Section B.

SECTION B

Main signal energy amplifier

This section of the invention has been arranged as an efficient three-stage amplifier and is provided, in combination, to receive input signal energy from Section A, amplify, then retransmit the same, at substantially a constant level into another communication circuit which may be connected to the output terminals C and D.

Signal energy present in the primary winding of T2 will be passed by induction into the secondary. One terminal of the latter is connected to ground, the other terminal to lead 5. Lead 5, with capacitor C2 in series, is connected with lead 7 which terminates in connection with one terminal each of R7 and R9 and with the base element of transistor Q1. The other terminal of R9 is grounded while the other terminal of R7 is connected to lead 6. From that junction point, lead 6 continues to a connection with one terminal each of R6, C1, and R8. The other terminal of R6 is connected with the negative power supply, the other terminal of C1 is grounded, while the other terminal of R8 is joined to lead 8 at a point between its connection with the collector of Q1 and one terminal of C3. The resistor R10 connects the emitter of Q1 to the common ground.

Lead 8 continues from a connection with the other terminal of C3 and terminates in a joint connection with one terminal each of R11, R12, and the base element of Q2. The emitter of Q2 is grounded via resistor R13. The collector of Q2 is connected to one terminal of the primary winding of T3 by lead 9. The other terminal of that winding is connected with the negative power supply.

To one terminal of the secondary winding of T3 is connected lead 10, the base element of Q3, and one terminal of R14. Lead 10 continues from the other terminal of R14 and the collector of Q3 to a connection with one terminal of the primary winding of output transformer T4. Lead 11 connects the other terminal of the secondary winding of T3 (it will be observed that this winding is connected to ground at its center point) with the base element of Q4 and with one terminal of R16. The other

5

terminal of R16 and the collector of Q4 are joined to the other terminal of the primary winding of T4 by a continuation of lead 11. The center point of that primary winding is connected to the negative power supply. The emitter elements of Q3 and Q4 are connected by R15 whose adjustable center point terminal is grounded.

The secondary winding of T4 is connected by leads 12-13 to terminals C and D respectively. Terminals C and D serve as the output terminals of the invention and as a terminus of another communication circuit to which the invention may be connected.

SECTION C

I have interposed the Section C arrangement between Sections B and D in order to momentarily retard the initial passage of small magnitude signal energy input from Section B to Section D. The Section C provision thus enables a slight delay in the development of optimum performance by the Section D arrangement and, in addition, helps to nullify the detrimental affect of spike or transient voltage on the Section A circuitry. All of these things are desirable in creating a proper regulation of the magnitude of input signal energy so that its subsequent emission from Section B as output signal energy will be at a substantially constant value.

With reference to FIGURE 1 of the drawing, Section C is electrically (lead 14) interposed between the Section B and D provisions and has another connection, lead 17, extending to a juncture with lead 18. Beginning at that point, the circuit continues via lead 17, resistor R17, and terminates in a connection with the positive terminals of D5 and D7. (For reasons presented hereinafter, R17 is provided to slightly retard passage of current to diodes D5, D6, D7 and D8 until the same is first effective upon diodes D1, D2, D3, and D4 of Section A.) The negative terminals of D5 and D7 are connected to the positive terminals of D6 and D8 by leads 15 and 16 respectively. Leads 15 and 16 terminate in connection with one terminal each of the primary winding of T5. The secondary winding of T5 is joined to lead 14 in shunt connection across R26, the latter being in series with lead 14.

SECTION D

This section of the invention is provided to maintain regulation of the Section A provision. I have constructed this in a novel manner as an alternating current amplifier, the output of which is rectified to direct current and utilized as the control medium for regulation of the overall impedance value of Section A.

With reference to FIGURE 1, it will be observed that the input circuit to the Section D arrangement is via lead 14 and the common ground. Lead 14 includes resistors R26, R25, and capacitor C8, connected in series in that order, and extends from a junction with lead 9 to a connection with the base element of Q6. Signal energy, emitted by the collector of Q2 into lead 9, will appear simultaneously in lead 14. Following appropriate regulation of its magnitude by the Section C provision, the energy is conducted to the base element of Q6 by a continuation of lead 14. The emitter of Q6 is connected to the common ground by resistor R22 which has the capacitor C6 in shunt connection. The base of Q6 is likewise connected to the common ground by resistor R23 and to the negative power supply by R24. The collector of Q6 is connected to the negative power supply by lead 23 which includes the series connected resistor R21. Lead 23 is joined by lead 20 at a point between R21 and the Q6 collector. Lead 20 continues from this connection and includes junctures with the following elements in the order named: the series connected capacitor C7, lead 22, the series connected diode D10, lead 21, the series connected resistor R20, the base element of transistor Q5, the series connected capacitor C4, and terminates in a connection with the common ground. Lead 21, with the series connected capacitor C5, terminates in a connection

6

with the common ground. Lead 22 also terminates in a connection with the common ground but includes the series connected diode D11. The collector of Q5 is connected to the negative power supply by resistor R19. Lead 19, connected to the emitter of Q5, includes the series connected diode D9 and terminates in a juncture with lead 18.

As in the case of the multiple diode D1, D2, D3, and D4 arrangement of Section A, the resistive impedance value of D9 varies in proportion to the amount of current flowing through that component, i.e., low impedance with current flow, high impedance without.

With Q5 in a near quiescent state and drawing minimum current because of the absence of proper bias at the time (i.e., for example, when Q6 is not receiving input energy via lead 14 with subsequent rectification of its emissions by D10), D9 offers high resistance to the passage of insignificant current present in lead 19 from the negative power supply via the collector, base, and emitter elements of Q5. However, with proper biasing of Q5 by negative voltage emissions of D10, Q5 then conducts, draws current, and emits same into the lead 19 from its emitter. With the flow of current through D9 thus arranged, its resistive impedance decreases, thereby, permitting less retardation to such current flow. This current, conducted via leads 19 and 18 to D1, D2, D3, and D4 is thereupon effective upon the Section A provision. This is true also in the case of D5, D6, D7, and D8 of Section C, the current flowing thereto from lead 18 via lead 17 and resistor R17. I have provided the latter to momentarily impede the functioning of Section C so as to enable Section A to reach optimum performance slightly in advance of Section C.

From the functional description outlined in the two preceding paragraphs, it is obvious that the multiple diode arrangements of Sections A and C remain in a high resistive impedance status during periods when Q5 is quiescent and non-conducting. The shunt circuit path between leads 3 and 4, as presented by D1, D2, D3, and D4 during such periods, is one of high resistance, and consequently, has an insignificant affect upon the passage of signal energy over those leads. Again, the shunt circuit across the primary winding of T5, as presented by diodes D5, D6, D7, D8, and the leads 15 and 16, is likewise one of high resistance during such periods and, consequently, has an insignificant short-circuiting affect upon that winding. In selecting T5, I chose a type of transformer having high impedance primary and secondary windings. The secondary, in shunt connection across R26, therefore functions normally as a high resistance shunt across that component and because of this causes only an insignificant change in its actual resistance. With current flow through D6, D7, D8, and D9, however, the resistive impedance value of those diodes is reduced thus presenting a more effective shunt across the primary winding of T5. As is well known in the art, the effect upon the secondary winding will, because of reflection, cause its impedance to be reduced, thereby, creating a more effective short circuit shunt across R26. Signal energy present in lead 14 will thereupon flow via the less resistive secondary winding rather than via the then higher resistive R26. This, from a functional standpoint, effectively removes that resistor from the circuit and reduces signal energy retardation via lead 14.

It is believed apparent that the invention is not necessarily confined to the specific use or uses thereof described above, since it may be utilized for any purpose to which it may be suited. Nor is the invention to be necessarily limited to the specific construction illustrated and described, since such construction is only intended to be illustrative of the principles of operation and the means presently devised to carry out said principles, it being considered that the invention comprehends any change in construction that may be permitted within the scope of the appended claims.

I claim:

1. For connection in a four-wire communications circuit of the type having a separate pair of conductors for the transmission of signals in each direction, apparatus to sense, at the location of the installation of the apparatus in the circuit, variations of a transmitted signal from a pre-selected magnitude and to restore the signal automatically to said magnitude for transmission beyond said location comprising:

- (a) an input section including
 - (1) a pair of leads connectable to one of said pairs of conductors to provide an input terminus, and
 - (2) a plurality of rectifiers in shunt across said leads;
- (b) a main amplifying section including
 - (1) an output of terminus connectable to said conductors,
 - (2) a line of signal transmission extending from the input section to said output terminus, and
 - (3) amplification means connected in said line to amplify a signal to a given magnitude in ratio to that of a signal input to the main section;
- (c) a signal-retard section including
 - (1) a pair of second leads
 - (2) a plurality of rectifiers in shunt across the second leads, and
 - (3) resistance means having a connection to the shunt connection of the second named amplifiers;
- (d) an impedance control section including
 - (1) a second line of signal transmission,
 - (2) amplifying means connected in said second line, and
 - (3) at least one rectifier arranged to rectify to direct current the output of the second-named amplifying means; and
- (e) a loop circuit extending from the first line of signal transmission to the first named rectifiers in series connection with the second line of signal transmission, said signal-retard section being connected across said loop circuit at a location between the impedance control section, and the input and main sections.

2. For connection in a four-wire communications circuit of the type having a separate pair of conductors for the transmission of signals in each direction, apparatus to sense, at the location of the installation of the apparatus in the circuit, variations of a transmitted signal from a pre-selected magnitude and to restore the signal automatically to said magnitude for transmission beyond said location, comprising:

- (a) an input section including
 - (1) a pair of leads connectable to one of said pairs of conductors to provide an input terminus, and
 - (2) a plurality of rectifiers connected in shunt across said leads and having a connection to ground;
- (b) a main amplifying section including
 - (1) an output terminus connectable to said conductors of the communications circuit for further transmission of a signal restored by the apparatus to a given, pre-selected magnitude,
 - (2) first signal transmission means connected between the input section and said output terminus, and
 - (3) amplification means connected in said means to amplify a signal to a given magnitude in ratio to the magnitude of a signal incoming to the main section;
- (c) a signal-retard section including
 - (1) a pair of second leads,
 - (2) a plurality of rectifiers connected in shunt across the second leads and having a connection to ground,

- (3) a third lead having a connection to the second named rectifiers, and
- (4) resistance means series-connected in the third lead; and
- (d) an impedance control section including
 - (1) second signal transmission means,
 - (2) amplifying means connected in the second transmission means for amplifying to a given magnitude a signal passing therethrough,
 - (3) means providing a connection between the respective signal transmission means and extending to a juncture with the second leads,
 - (4) at least one rectifier arranged to rectify to direct current the amplified output of the impedance control section, and
 - (5) a connection between the first and last-named rectifiers and having a juncture with the third lead.

3. For connection in a four-wire communications circuit of the type having a separate pair of conductors for the transmission of signals in each direction, apparatus to sense, at the location of the installation of the apparatus in the circuit, variations of a transmitted signal from a pre-selected magnitude and to restore the signal automatically to said magnitude for transmission beyond said location, comprising:

- (a) an input section including
 - (1) a pair of leads connectable to one of said pairs of conductors to provide an input terminus,
 - (2) first and second rectifier means connected in shunt across said leads, and
 - (3) a connection extending from the second rectifier means to ground;
- (b) a main amplifying section including
 - (1) an output terminus connectable to said conductors of the communications circuit for further transmission of a signal restored by the apparatus to a given, pre-selected magnitude,
 - (2) a signal transmission line connected between the input section and the output terminus, and
 - (3) amplification means connected in said line to amplify a signal to a given magnitude in ratio to the magnitude of a signal incoming to the main section;
- (c) a signal-retard section including
 - (1) a pair of second leads,
 - (2) third and fourth rectifier means connected in shunt across said second leads,
 - (3) a connection between the fourth rectifier means and ground,
 - (4) a third lead connected to the shunt connection of the third rectifier means, and
 - (5) resistance means series-connected in the third lead; and
- (d) an impedance control section including
 - (1) a second signal transmission line,
 - (2) amplifying means connected in the second line for amplifying to a given magnitude a signal passing therethrough,
 - (3) means providing a connection between said signal transmission lines and extending to a juncture with the respective second leads,
 - (4) fifth rectifier means series-connected in the second line of signal transmission and operative to rectify the amplified current output of the impedance control section to direct current, and
 - (5) means providing a connection between the first and fifth rectifier means and said third lead.

4. For connection in a four-wire communications circuit of the type having a separate pair of conductors for the transmission of signals in each direction, apparatus to sense, at the location of the installation of the apparatus in the circuit, variations of a transmitted signal from a pre-selected magnitude and to restore the signal

automatically to said magnitude for transmission beyond said location, comprising:

- (a) an input section including
 - (1) a pair of leads connectable to one of said pairs of conductors to provide an input terminus, 5
 - (2) a pair of first and a pair of second rectifiers connected between said leads, and
 - (3) a connection from the second rectifiers to ground;
- (b) a main amplifying section including 10
 - (1) an output terminus connectable to said conductors of the communications circuit for further transmission of a signal restored by the apparatus to said pre-selected magnitude,
 - (2) a signal transmission line connected between 15 the input section and the output terminus, and
 - (3) amplification means connected in said line to amplify a signal to a given magnitude in ratio to the magnitude of a signal incoming to the main section; 20
- (c) a signal-retard section including 20
 - (1) a pair of second leads,
 - (2) a pair of third and a pair of fourth rectifiers connected across said second leads,
 - (3) a connection between the fourth rectifiers and 25 ground,
 - (4) a third lead connected to the third rectifiers, and
 - (5) resistance means connected in the third lead; 30 and
- (d) an impedance control section including 30
 - (1) a second signal transmission line,
 - (2) amplifying means connected in the second line for amplifying a signal passing therethrough 35 to a given magnitude at the output end of the second line,
 - (3) a fourth lead connected between the first and second signal transmission lines, said second leads being connected to the fourth lead,
 - (4) a fifth rectifier series-connected in the second 40 line for rectifying current amplified within the impedance control section to direct current, and
 - (5) a fifth lead connected between the first and fifth rectifiers and having a connection to the 45 third lead.

5. For connection in a four-wire communications circuit of the type having a separate pair of conductors for the transmission of signals in each direction, apparatus to sense, at the location of the installation of the apparatus in the circuit, variations of a transmitted signal 50 from a pre-selected magnitude and to restore the signal automatically to said magnitude for transmission beyond said location, comprising:

- (a) an input section including
 - (1) a pair of leads connectable to one of said 55 pairs of conductors to provide an input terminus,
 - (2) a first resistor connected in shunt across said leads,
 - (3) a plurality of second resistors connected in series in each of said leads, 60
 - (4) a pair of first and a pair of second rectifiers connected between said leads, and
 - (5) a connection from the second rectifiers to ground;
- (b) a main amplifying section including 65
 - (1) an output terminus connectable to said conductors of the communication circuit for further transmission of a signal received by the apparatus and restored thereby to the pre-selected 70 magnitude,
 - (2) a signal transmission line connected between the input section and the output terminus, and
 - (3) amplification means connected in said signal transmission line and arranged to amplify a signal 75 passing therethrough to a given magnitude

in ratio to the magnitude of the signal incoming to the main amplifying section;

- (c) a signal-retard section including
 - (1) a pair of second leads,
 - (2) a pair of third and a pair of fourth rectifiers connected across said second leads,
 - (3) a connection between the fourth rectifiers and ground,
 - (4) a third lead connected at one end to the third 10 rectifiers,
 - (5) a third resistor series-connected in the third lead, and
 - (6) a fourth resistor connected between the second leads; and
 - (d) an impedance control section including
 - (1) a second signal transmission line,
 - (2) amplifying means connected in the second line and arranged to amplify a signal passing there- 15 through to a given magnitude at the output end of the second line in ratio to the magnitude of said signal when passed into the input end of the second line,
 - (3) a fourth lead connected between the first and second signal transmission lines, a portion of the fourth lead having the fourth resistor series con- 20 nected therein and constituting the connection of the fourth resistor across the second leads,
 - (4) a fifth rectifier series connected in the second line at the output end thereof for rectifying current amplified within the impedance control section to direct current, and
 - (5) a fifth lead connected between the fifth and 25 first rectifiers, the third lead being connected to said fifth lead.
6. For connection in a four-wire communications circuit of the type having a separate pair of conductors for the transmission of signals in each direction, apparatus to sense, at the location of the installation of the apparatus in the circuit, variations of a transmitted signal from a pre- 30 selected magnitude and to restore the signal automatically to said magnitude for transmission beyond said location, comprising:
- (a) an input section including
 - (1) a pair of leads connectable to one of said pairs 35 of conductors to provide an input terminus,
 - (2) a first resistor connected in shunt across said leads,
 - (3) a pair of second resistors connected in series in each of said leads,
 - (4) a pair of first and a pair of second rectifiers con- 40 nected in shunt across said leads at a location between the series-connected resistors, the first rectifiers having their negative terminals connected to the respective leads and the second rectifiers having their positive terminals connected to the respective leads, and
 - (5) a connection extending to ground from a location 45 between the respective second rectifiers;
 - (b) a main amplifying section including
 - (1) an output terminus connectable to said pair 50 of conductors of the communication circuit for further transmission of a signal received by the apparatus and restored thereby to the pre-selected magnitude,
 - (2) a signal transmission line connected between the input section and the output terminus, and
 - (3) amplification means connected in said signal transmission line and arranged to amplify a 55 signal passing therethrough to a given magnitude in ratio to the magnitude of said signal when passing into the main amplifying section from the input section;
 - (c) a signal-retard section including
 - (1) a pair of second leads,
 - (2) a pair of third and a pair of fourth rectifiers 60

11

- connected in shunt across said second leads, the third rectifiers having their negative terminals connected to one end of the respective second leads and the fourth rectifiers having their positive terminals connected to the respective second leads, 5
- (3) a connection to ground extending from a location between the fourth rectifiers,
- (4) a third lead connected at one end to the positive terminals of the third rectifiers, 10
- (5) a third resistor series connected in the third lead, and
- (6) a fourth resistor connected between the other ends of the second leads; and
- (d) an impedance control section including 15
 - (1) a second signal transmission line having input and output ends,
 - (2) amplifying means connected in said second line and arranged to amplify a signal passing therethrough to a given magnitude at the output end of the second line in ratio to the magnitude of said signal when passed into the input end of the second line, 20
 - (3) a fourth lead connected between the first signal transmission line and the input end of the second signal transmission line, a portion of the fourth lead having the fourth resistor series connected therein and constituting the connection of the fourth resistor across the second leads, 25
 - (4) a fifth rectifier series connected in the second signal transmission line at the output end thereof for rectifying current amplified within the impedance control section to direct current, and 30
 - (5) a fifth lead connected between the fifth rectifier and the positive terminals of the first rectifiers, the third lead being connected at its other end to the fifth lead intermediate the ends of the fifth lead. 35

7. For connection in a four-wire communications circuit of the type having a separate pair of conductors for the transmission of signals in each direction, apparatus to sense, at the location of the installation of the apparatus in the circuit, variations of a transmitted signal from a pre-selected magnitude and to restore the signal automatically to said magnitude for transmission beyond 45 said location, comprising:

- (a) an input section including
 - (1) a pair of leads connectable at one end to one of said pairs of conductors of said circuit to provide an input terminus, 50
 - (2) a first transformer connected between said leads,
 - (3) a second transformer connected between said leads at the other ends thereof,
 - (4) a first resistor connected in shunt across said leads at a location between the transformers, 55
 - (5) a pair of second resistors connected in series in each of said leads at a location between said shunt and the second transformer,
 - (6) a pair of first and a pair of second rectifiers connected in shunt across said leads at a location between the series-connected resistors, the first rectifiers having their negative terminals connected to the respective leads and the second rectifiers having their positive terminals connected to the respective leads, and 60
 - (7) a connection extending to ground from a location between the second rectifiers;
- (b) a main amplifying section including 65
 - (1) an output terminus connectable to said pair 70

12

- of conductors of the communication circuit for further transmission of a signal received by the apparatus and restored thereby to the pre-selected magnitude,
- (2) a signal transmission line connected between the second transformer and said output terminus, and
- (3) amplification means connected in said signal transmission line and arranged to amplify a signal passing therethrough to a given magnitude in ratio to the magnitude of said signal when passed into the main amplifying section from the input section;
- (c) a signal-retard section including
 - (1) a pair of second leads,
 - (2) a pair of third and a pair of fourth rectifiers connected in shunt across said second leads, the third rectifiers having their negative terminals connected to one end of the respective second leads and the fourth rectifiers having their positive terminals connected to the respective second leads,
 - (3) a connection extending to ground from a location between the fourth rectifiers,
 - (4) a third lead connected at one end to the positive terminals of the third rectifiers,
 - (5) a third resistor series-connected in the third lead,
 - (6) a fourth resistor connected between the other ends of the second leads, and
 - (7) a third transformer connected between the second leads at a location between said other ends of the second leads and the shunt of the fourth rectifiers thereacross; and
- (d) an impedance control section including
 - (1) a second signal transmission line having input and output ends,
 - (2) amplifying means connected in said second line and arranged to amplify a signal passing therethrough to a given magnitude at the output end of the second line in ratio to the magnitude of said signal when passed into the input end of the second line,
 - (3) a fourth lead connected between the first signal transmission line and the input end of the second signal transmission line, a portion of the fourth lead having the fourth resistor series-connected therein and constituting the connection of the fourth resistor across the second leads,
 - (4) a fifth rectifier series-connected in the second signal transmission line at the output end thereof for rectifying current amplified within the impedance control section to direct current, and
 - (5) a fifth lead connected between the fifth rectifier and the positive terminals of the first rectifiers, the third lead being connected at its other end to the fifth lead intermediate the ends of the fifth lead. 75

References Cited by the Examiner

UNITED STATES PATENTS

2,193,966	3/1940	Jones	-----	330-145
3,210,680	10/1965	Farris	-----	330-145
3,226,653	12/1965	Miller	-----	330-141

KATHLEEN H. CLAFFY, Primary Examiner.

H. ZELLER, Assistant Examiner.