

(19)



(11)

EP 2 085 562 A2

(12)

EUROPEAN PATENT APPLICATION

(43) Date of publication:

05.08.2009 Bulletin 2009/32

(51) Int Cl.:

E06B 9/52 (2006.01)

(21) Application number: **09001215.4**

(22) Date of filing: **29.01.2009**

(84) Designated Contracting States:

**AT BE BG CH CY CZ DE DK EE ES FI FR GB GR
HR HU IE IS IT LI LT LU LV MC MK MT NL NO PL
PT RO SE SI SK TR**

Designated Extension States:

AL BA RS

(72) Inventors:

- **Bettio, Denis**
30170 Mestre (VE) (IT)
- **Bettio, Loris**
30170 Mestre (VE) (IT)

(30) Priority: **01.02.2008 IT TV20080020**

(74) Representative: **Massa, Patrizia**

D'Agostini Group S.r.l.
Viale Mazzini 142
00195 Roma (IT)

(71) Applicant: **Bettio Service Spa**
30020 Marcon (VE) (IT)

(54) **Mosquito-net with rollaway net-guiding chain for net with horizontal sliding**

(57) Mosquito-net with rollaway net-guiding chain for net with horizontal sliding, made up of:

- a) a vertical roller shutter box (10) containing a roller (100), lateral compared to a horizontal and fixed upper guide (30), said net joined with a first end to the roller (100);
- b) a horizontal and fixed upper guide (30);
- c) a vertical handlebar (20) to which the second end of the net is joined, with the upper end fixed to the fixed guide and mobile longitudinally;

d) a net-guiding chain (40) with containing seat of the lower border (201) of the net; consisting of modular elements (41) reciprocally interconnected, with a engaged first end (400) at the lower end of the roller shutter box (100), while the second end slides inside the handlebar (20);

e) a driving device of the net-guiding chain (40), comprising at least a rope (70), chain (50), and relative transmission means placed at least at the handlebar (20) and the roller shutter box (10).

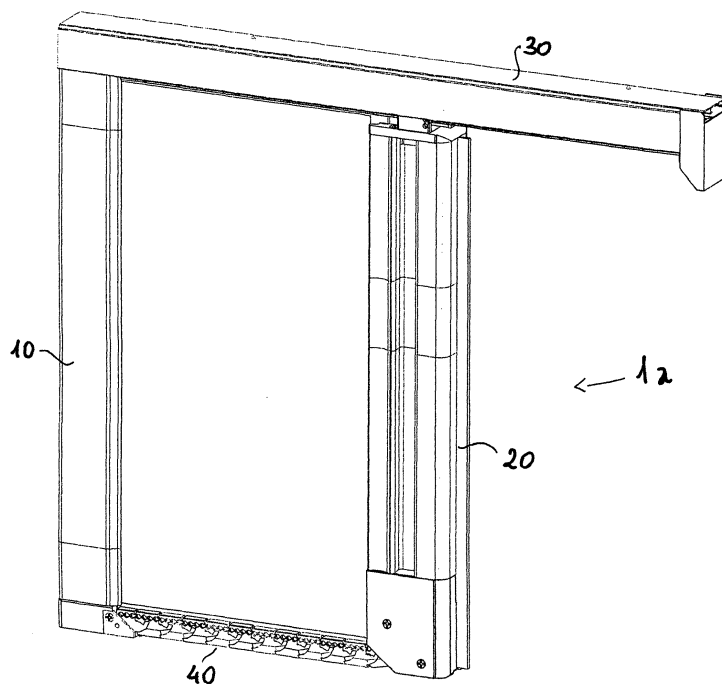

FIG. 1

EP 2 085 562 A2

Description

[0001] The subject of this invention is a mosquito-net with rollaway net-guiding chain for net with horizontal sliding.

Domain

[0002] The invention, finds particular even if not exclusive application in the field of mosquito-nets suitable for preventing insects from entering conventionally inhabited places, for example houses and offices.

[0003] The mosquito-nets can be put into two categories. A first, so-called made-to-measure, that is a type of mosquito-net realised according to sizes received from the client, to be delivered to the final recipient allowing for the installation by specialist staff; a second, indicated as mosquito-net in assembly kits, is that much more common on the market.

[0004] In both said categories of mosquito-nets, there are common realization elements; which can be explicated by the roller shutter box, of the type generally given by a profile or extruded aluminium bar, on the inside of which is coaxially inserted the mosquito-net roller. In the non-motorized version, the roller may also include one corresponding preloaded return spring. Concerning the ends of the roller shutter box, they are normally closed by suitable plates, or better heads, which are supplied in two versions, fixed or with counter-plates or caps which are adjustable. The roller shutter box combines in the installation with one or more guides or slide-ways, inside of which the end of the handlebar and the corresponding side edge of the net slides in and out.

[0005] There are also known variations, which however are very similar to the described solutions and are recurrent, as much in the mosquito-nets, as in rolling curtains and, finally, in the shade curtains. One of these, for example, regards less valuable mosquito-nets, without the preloaded spring inside. These are differentiated from the first ones, because they require manual operations, both for unwinding the curtain from the roll and for rewinding it. In one case, for example, a closed circuit chain is used, which engaging, from one side, a wheel or pulley keyed to the relative roller, housed in a roller shutter box, determines the winding, or unwinding of the mosquito-net in a controlled way.

[0006] These mosquito-net solutions, which slide the net horizontally or vertically, are therefore composed as such:

- a) a roller shutter box, closed at the ends by corresponding heads;
- b) a roller, inside said roller shutter box, supported at the ends by a couple of heads, which are engaged at the end of the roller shutter box;
- c) a possible helicoidal torsion spring placed coaxially, cooperating with said roller;
- d) a net, anchored on one side to said roller and at

the other joined to a handlebar;

e) and finally, in the solution with vertically sliding net, two parallel slide-ways, inside of which are slideable ends of said handlebar and the side flaps of the net. For the horizontally sliding net, the slide-ways act as guides, and usually are placed, respectively, a first one along the lintel of the opening to be closed and a second one along the lower plane.

10 Prior art

[0007] In EP753642 (Metaco) a shielding device for a horizontally sliding screen is described, comprising a foldable shield that is pleated, having a base side, a left-hand side and a right-hand side, the shield extending longitudinally between a left-hand frame element extending upwards and a right-hand frame element extending upwards, longitudinally movable the one with respect to the other in order to open the foldable shield, the apparatus including moreover a top guide element extending longitudinally and an base guide element extending longitudinally, each guide element being flexible and bent in a cross direction adjacently to one of the left-hand and right-hand frame elements so as to present a free end that moves downwards and upwards as regards one of said left-hand and right-hand frame elements when the shield is opened or closed, each guide element having flexing elasticity determining an elastic return force, characterised in that the free ends of each guide element slides along one of said left-hand or right-hand frame elements, in that the other end of each guide element is fixed to the other one of the left-hand and right-hand frame elements, and in that the left-hand frame element, the right-hand frame element, the top guide element and the base guide element form a frame.

[0008] EP 999335 (Metaco) describes a shielding device including:

- a couple of assembly frames of the shield respectively opposite, at least one of which is sliding;
- a shield mounted between said assembly frames of the shield in order to allow for its opening and closing;
- a sliding guide frame situated close to a side of said shield not connected to the shield assembly frame, at least one end of which is an insertable free end and is extractable from inside of one of said shield assembly frames.

Said guide frame is formed by a number of interconnected rigid units, each of which presents a couple of side-walls respectively opposite and a connecting portion that interconnects said side-walls, adjacent rigid units being turnable between each other so that the sliding guide frame is foldable; stopping means associated to said rigid units, said stopping means preserving the straightness of an extracted portion of the sliding guide frame when the sliding guide frame is extracted from the assembly frame of the shield at the sliding of the assembly frame

of the sliding shield.

[0009] Guides made up with rigid units consecutively interconnected are known. In JP 53-51648 the guide is pointed out, formed by rigid units consecutively hinged, a section of which extends in parallel to the edges of the screen. An end of the structure formed by the concatenated portions is received and extracted from the inside of the screen assembly frame, represented by the box or roller shutter box. In JP 06-158961, one can gather that it proposes the use of folding guide structures made up of consecutively interconnected rigid units, extending along the opposite edges of a curtain and presenting end segments to be extracted and inserted in one of the stanchions of the framework. It clearly relates to a shielding device having a curtain extending between a fixed stanchion and a movable stanchion. Along each of the opposite horizontal edges of the curtain, there is a flexible guide structure made up of a number of rigid units pivotably connected one after another by means of pins. The guide structure, engaged in a slidable way along a fixed section, presents an end fixed on the movable stanchion and an end section sliding and guided along a shaped prolongation of the section. The guide structure therefore maintains a rectilinear development in the section extracted from the fixed stanchion, and flexes at the input opening in the stanchion to be housed and extracted from the same in accordance with the opening and closing movements of the curtain.

In conclusion, it is also reasonable to consider known:

- a) a shielding body that includes a base, two sides and a top;
- b) two longitudinally movable vertical stanchions;
- c) an upper guide element and a lower guide element which are flexible and folded along one of the stanchions with a free end that moves downwards and upwards;
- d) the end opposite to the free one of the upper and lower guide elements is engaged along the stanchion;
- e) the stanchions and the upper and lower guide elements form a frame.

Furthermore:

- a) a couple of stanchions, shield or screen assembly frame, at least one sliding;
- b) a screen;
- c) a sliding guide element, not connected to the couple of stanchions, with an end free to slide in one of said stanchions;
- d) the sliding guide element is formed by adjacent rigid interconnected units, each with a couple of parallel side-walls and a connecting portion that joins the walls, and in which the rigid units turn so that the guide element is foldable;
- e) stopping means that preserve the straightness of the guide element portion when it is extracted from

the stanchion.

Drawbacks

5 **[0010]** From the functional point of view, the represented screen solutions all aim to contain, if not apparently eliminate, the visual impact of horizontal and parallel guides that are usually placed along the horizontal levels that delimit, on the upper and lower part the architectonic opening to be closed with said protective screen. However, the represented solutions are not able to minimize the sizes of guides where present, with an aesthetic aspect that results in conclusion little acceptable. Furthermore, as regards the solutions both with guides and without guides, the mechanisms are not particularly efficient in allowing for manageable, that is smooth, screen movement, without stick-slip-motions, thus not guaranteeing linear sliding and the correct tension of the net. In addition, the illustrated solutions seem constructively complex, not easily manufacturable also due to the presence of a large number of codes that complicate warehouse management.

[0011] From these introductory considerations, identifying alternative solutions is certainly preeminent.

25 **[0012]** The aim of this invention is also to avoid the above-mentioned drawbacks.

Summary of the invention

30 **[0013]** This and other aims are reached by the present invention according to the characteristics as in the included claims solving the arising problems by means of a mosquito-net with rollaway net-guiding chain for net with horizontal sliding, made up of:

- a) a vertical roller shutter box, lateral as regards a horizontal and fixed upper guide, containing the net roller; said net is joined with a first end to the roller;
- b) a horizontal and fixed upper guide, joined with an end at the upper end of the vertical roller shutter box;
- c) a vertical handlebar to which the second end of the net is joined; the handlebar being with the upper end constrained to the fixed guide and mobile longitudinally as to said fixed guide;
- d) a net-guiding chain with seat containing the lower edge of the net; the net-guiding chain consisting of modular elements which are interconnected, where said net-guiding chain is with a first end engaged to the lower end of the roller shutter box, while the second end slides inside the handlebar;
- e) a driving device of the net-guiding chain, comprised at least of a rope, chain, and relative transmission means placed at least inside the handlebar and the roller shutter box.

Aims and advantages

[0014] In this way, by the considerable creative contri-

bution the effect of which constitutes immediate technical progress, multiple advantages are achieved.

[0015] A first and unquestionable value, as regards the conventional mosquito-nets, consists in the fact that the mosquito-net does not have a lower guide, and in any case, for particularly wide openings, can provide also a thin and rectilinear line but that however has an extremely contained thickness (less than 3mm with a tolerance of $\pm 0.2\text{mm}$). Moreover, said thin line has no guide function for facilitating the rectilinear sliding of the handlebar, but is only a means for containing the side oscillation of the net-guiding chain. Under the practical profile, when the mosquito-net is not pulled out, that is, the net is wound on the corresponding roller, it is not visible or significantly visible, along the lower plane of the architectonic opening to be closed, any element that can be little aesthetically acceptable and obstacle to the free transit of people and things.

[0016] Compared to the previous solutions, the provision of the roller, inside the roller shutter box, allows for a persistent yet light tension on the net, which, when pulled out offers greater guarantee of effectiveness against intruding insects, and simultaneously the tensesness remains uniform and particularly resisting to the deformations also with insistent pressure on the surface of same, e.g. because of a faster air circulation or usual gusts of wind.

[0017] Moreover, because of the particular driving device, the movement of the handlebar is smooth and easy, whether the net is pulled out or wound up, requiring only slight effort from the user.

[0018] One more aim is that the assembly and vice-versa of the mosquito-net is more effective and noticeably comfortable, the roller shutter box is contained dimensionally, favouring housing in the narrow seats and as a whole with less visual impact.

[0019] These and other advantages will appear from the following detailed description of at least one preferred solution with the aid of enclosed schematic drawings whose details are not to be considered limitative but only illustrative.

Content of drawings

[0020]

Figure 1, represents the mosquito-net mounted with horizontally sliding net, in a first solution without line.

Figure 2, represents the mosquito-net mounted with horizontally sliding net, in a second solution, with side oscillation containing line.

Figure 3 is the mosquito-net of Figure 1 in an exploded view;

Figure 4 is the mosquito-net of Figure 2 in an exploded view;

Finally, figure 5 is an exploded view of main components of the mosquito-net of Figure 1 and 2, respectively; handlebar, roller, driving device, and net-guid-

ing chain.

Practical realization of the invention

[0021] With reference to figures 1 and 2 the mosquito-net 1a, 1 b, includes at least: a side and vertical roller shutter box 10 that contains a roller 100 of the net or screen 200, a ; handlebar 20, a fixed upper guide 30 and a lower net-guiding chain 40.

[0022] Inside the roller shutter box 10, made up of a box-like element, metallic, closed by a base 11 and a head 12, the roller 100 (figs. 3, 4) is longitudinally housed, with the related net or screen 200. The net or screen 200 is with a first end joined to said roller 100 around which it is wound, then turned exiting sideways from the roller shutter box 10 by means of the coming and going movement, along the horizontal axis of the handlebar 20 to which said net 200 is vertically joined with the second end. The upper end 21 of the handlebar 20 is driven by the upper guide 30, horizontal, that is fixed at the lintel of the architectonic opening, while the lower end 22 is configured so as to lay down, with the participation of the driving device, the net-guiding chain 40 that also slides inside and along the handlebar 20. The function of the net-guiding chain 40 is particularly to hold and drive during its distending, after the movement of the handlebar 20, the lower border 201 of the net 200, while the top edge 202 of the net 200 slides and remains inside the upper guide 30.

[0023] The roller 100 that is vertically contained inside the roller shutter box 10, comprises (figures 3, 4 and 5) of a cylindrical pipe, on the surface of which it clamps the first end of the net 200. Inside the pipe there is a spiral spring 102, coaxial to a sleeve 103, this spiral spring 102 on one side is joined to a key 104 that is attached along the inside wall of the cylindrical pipe, on the other exiting from the sleeve 103, engaging a shaft 105, with a gear-wheel 106 keyed on the top. The roller 100, is thus introduced inside the roller shutter box 10 and is held in vertical position by means of the base 11 and head 12 (figure 3) that close the two ends, respectively lower and upper, of the roller shutter box 10.

[0024] The base 11, besides closing the lower end of the roller shutter box 10, allowing pivoting by means of the pin 110 of the roller 100 closed by the head 107, is provided with two side appendixes 111 (figure 3 and 4) to the which the first end 400 of the net-guiding chain 40 (figure 5) is engaged . The head 12 (figure 3 and 4) that is applied on the upper part of the roller shutter box 10 is shaped with a recess 120 inside of which the gear-wheel 106 is housed that is connected with the spiral spring 102.

[0025] The driving device (figure 5) of the net-guiding chain 40 includes the gear-wheel 106, which engages the chain 50 made up at least for a part by a number of balls one after another with the first end 51 that is engaged at the upper end 21 of the handlebar 20. The chain 50 that originates from the handlebar 20 runs along and

inside the upper guide 30, carries out a geared first turn around the gear-wheel 106, and then by means of a pulley 60 hinged in the upper end 21 of the handlebar 20 is transmitted towards the lower end 22 of the handlebar 20. At the lower end 22 of the handlebar 20 the pulley 61 is hinged around which the rope portion of the chain 50 rotates to be forced upwards to turn around the pulley 62 that is hinged to the head module 41 of the net-guiding chain 40, then again transmitted downwards in such a way that the second end 52 fixes at the lower end 22 of the handlebar 20. In this case, the net-guiding chain 40 consists of a series of modules 41, one hinged to another, in such a way as to result reciprocally concatenated, and slides longitudinally guided inside the handlebar 20 that is hollow. A rope 70 is placed along the fixed upper guide 30 with a first end 71 engaged at the end 301 of the fixed upper guide 30 and with the second end 72 transmitted by means of the pulley 63 hinged on the top 21 of the handlebar 20 downwards, to be engaged to the head module 41 of the net-guiding chain 40.

[0026] The handlebar 20 at the lower end 22 is shaped to provide a curved guide 220 accessible through the removal of a cover 221 along which the net-guiding chain 40 is transmitted to scroll along the handlebar 20.

[0027] In the solution of figure 1 and 3, the mosquito-net 1a is shown only with the lower net-guiding chain 40 that is de-placed on the lower plane of the architectonic opening, holding only the lower edge 201 of the net 200, each module 41 on the upper part being configured in such a way as to provide a continuous seat 410 inside of which said lower edge 201 of the net 200 is longitudinally housed. As regards, the solution of figures 2 and 4, the mosquito-net 1 b suitable for a mosquito-net of particular width, provides the combination of a thin rectilinear line 80, applied along the plane of the architectonic opening, along which lays the net-guiding chain 40, whose thickness is less than 3mm, in this case with a tolerance of $\pm 0.2\text{mm}$. In this case the function of the net-guiding chain 40 is also to prevent the possible side oscillation of said net 200 and of the net-guiding chain 40, each module 41 being provided with a lower corresponding seat, in such a way as to obtain a continuous seat 411, that develops for the whole length of the net-guiding chain 40. The seat 411 then substantially straddles the thin line 80 with the parallel walls 412, at the longitudinal edges of the thin line 80. In this way the alignment of the net-guiding chain 40 is also assured, simplified by the possible presence of a sliding guide placed at the lower end 22 of the handlebar 20.

Reference

[0028]

1 a, 1 b, mosquito-net
10 side and vertical roller shutter box
100 roller
102 spiral spring

103 sleeve
104 key
105 shaft
106 gear-wheel
200 net or screen
201 lower edge
202 upper edge
20 handlebar
21 upper end
22 lower end
220 curved guide
221 cover
300 fixed upper guide
301 end
40 lower net-guiding chain
41 head module
400 first end
410 continuous upper seat
411 continuous lower seat
412 parallel walls
11 base
110 pin
111 side appendixes
12 head
120 recess
107 head
50 chain
51 first end
52 second end
60 pulley
61 pulley
62 pulley
63 pulley
70 rope
71 first end
72 second end
80 thin line

40 Claims

1. Mosquito-net with rollaway net-guiding chain for net with horizontal sliding, **characterised in that** it consists of:

- a) a vertical roller shutter box 100, lateral as compared to a horizontal and fixed upper guide 30, containing the roller 100 of the net 200; the net 200 is joined with a first end to the roller 100;
b) a horizontal and fixed upper guide 30 joined with one end at the upper end of the vertical roller shutter box 100;
c) a vertical handlebar 20 to which the second end of the net 200 is joined; the handlebar 20 being with the upper end 21 constrained to the fixed guide 30 and mobile longitudinally as to the said fixed guide 30;
d) a net-guiding chain 40 with containing seat

- 410 of the lower border 201 of the net 200; the net-guiding chain 40 consisting of modular elements 41 reciprocally interconnected, where said net-guiding chain 40 is with a first end 400 engaged at the lower end of the roller shutter box 100, while the second end slides inside the handlebar 20;
- e) a driving device of the net-guiding chain 40, comprising at least a rope 70, chain 50, and relative transmission means placed at least at the handlebar 20 and the roller shutter box 10.
2. Mosquito-net with rollaway net-guiding chain for net with horizontal sliding, according to claim 1, **characterised in that** the net-guiding chain 40 consisting of a series of modules 41 one hinged to the other in a removable manner, resulting reciprocally concatenated, that slides longitudinally guided inside the hollow handlebar 20, is provided with upper seat 410 inside of which the lower border 201 of the net 200 is housed in an engaged manner.
 3. Mosquito-net with rollaway net-guiding chain for net with horizontal sliding, according to claim 1, **characterised in that** the roller 100 of the net 200 contained in the roller shutter box 10 includes a charging spring 102, and a gear-wheel 106.
 4. Mosquito-net with rollaway net-guiding chain for net with horizontal sliding, according to claims 1 and 2, **characterised in that** the driving device of the net-guiding chain 40 is composed of:
 - gear-wheel 106 that engages the chain 50 with the first end 51 engaged at the upper end 21 of the handlebar 20; the chain 50 that originates from the handlebar 20 runs along and inside the upper guide 30, carries out a first turn geared around the gear-wheel 106, and by means of a pulley 60 hinged in the upper end 21 of the handlebar 20 is transmitted towards the lower end 22 of the handlebar 20 where the pulley 61 is hinged around which the rope portion of the chain 50 rotates to be forced upwards to turn around the pulley 62 that is hinged to the head module 41 of the net-guiding chain 40, then again transmitted downwards in such a way that the second end 52 fixes at the lower end 22 of the handlebar 20;
 - rope 70 situated along the fixed upper guide 30, with a first end 71 engaged at the end 301 of the fixed upper guide 30 and with the second end 72 transmitted by means of the pulley 63 hinged on the top 21 of the handlebar 20 downwards, fixed to the head module 41 of the net-guiding chain 40.
 5. Mosquito-net with rollaway net-guiding chain for net with horizontal sliding, according to the previous claims, **characterised in that** the base 11 shuts the lower ends of the roller shutter box 10, and by means of the pin 110, hinges the roller 100 closed by the head 107; said base 11 provided with two side appendixes 111 to which the first end 400 of the net-guiding chain 40 is engaged.
 6. Mosquito-net with rollaway net-guiding chain for net with horizontal sliding, according to the previous claims, **characterised in that** the head 12 is shaped with a recess 120 inside of which the gear-wheel 106 is housed that is connected with the spiral spring 102.
 7. Mosquito-net with rollaway net-guiding chain for net with horizontal sliding, according to the previous claims, **characterised in that** it requires the thin line 80, applied along the plane of the architectonic opening, along which the net-guiding chain 40 is situated, said thin line 80 being between 1 mm and 3mm thick, with a tolerance of $\pm 0.2\text{mm}$.
 8. Mosquito-net with rollaway net-guiding chain for net with horizontal sliding, according to the previous claims, **characterised in that** each module 41 of the net-guiding chain 40 has below one corresponding seat, in such a way as to obtain a continuous seat 411, that develops for the whole length of the net-guiding chain 40, said seat 411 substantially straddling the thin line 80 with the parallel walls 412, at the longitudinal edges of the thin line 80.

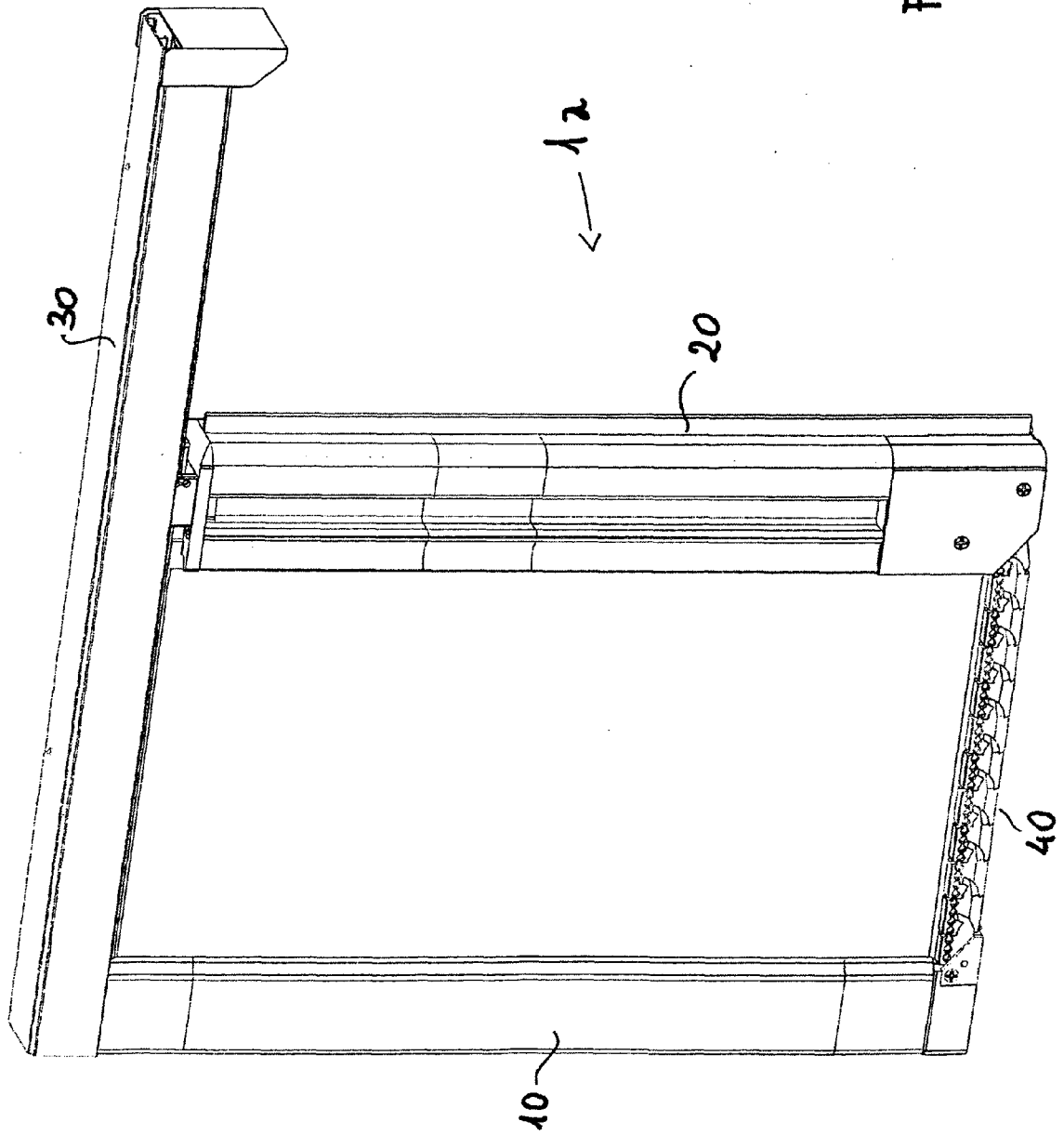
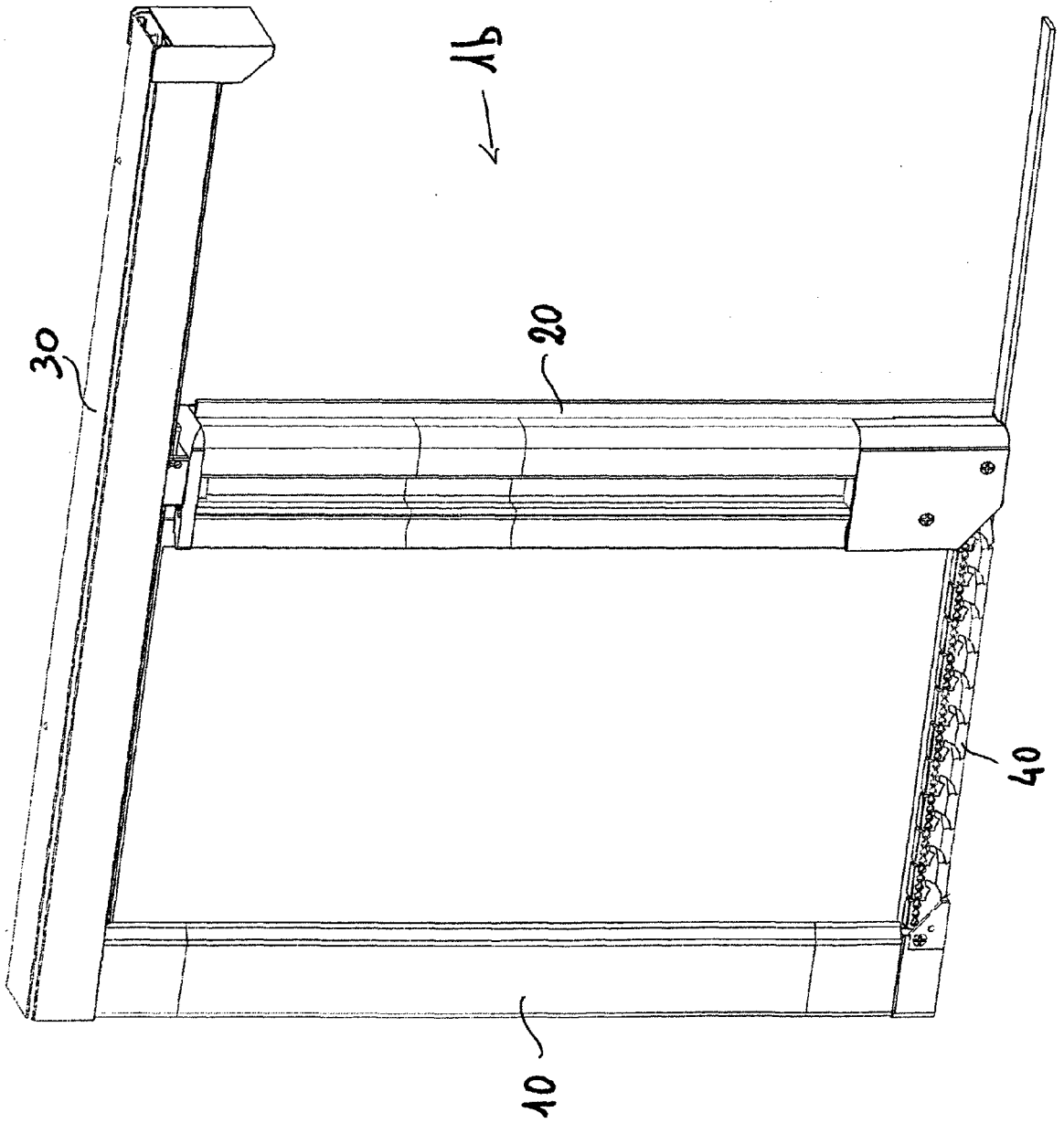
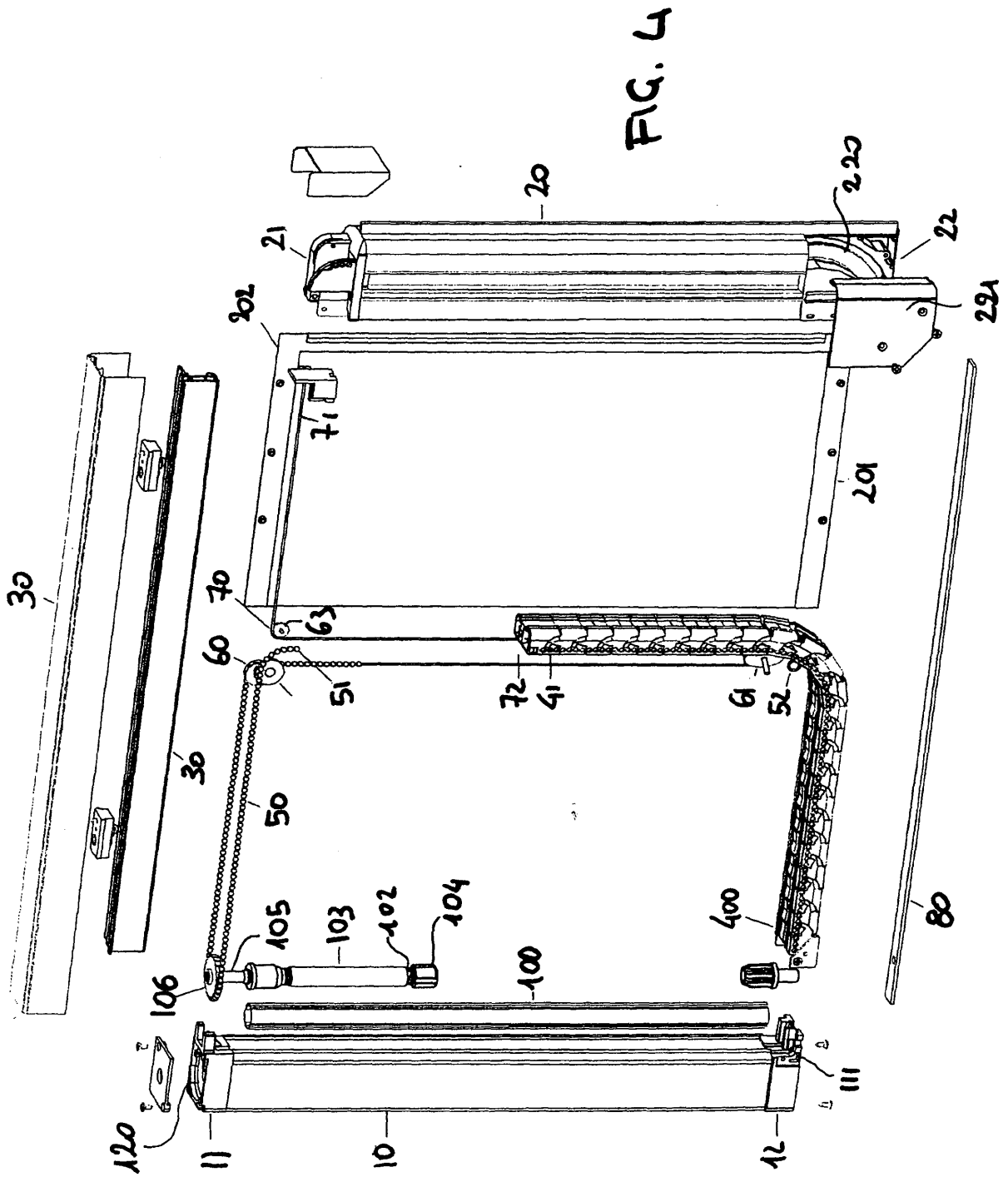

Fig. 1





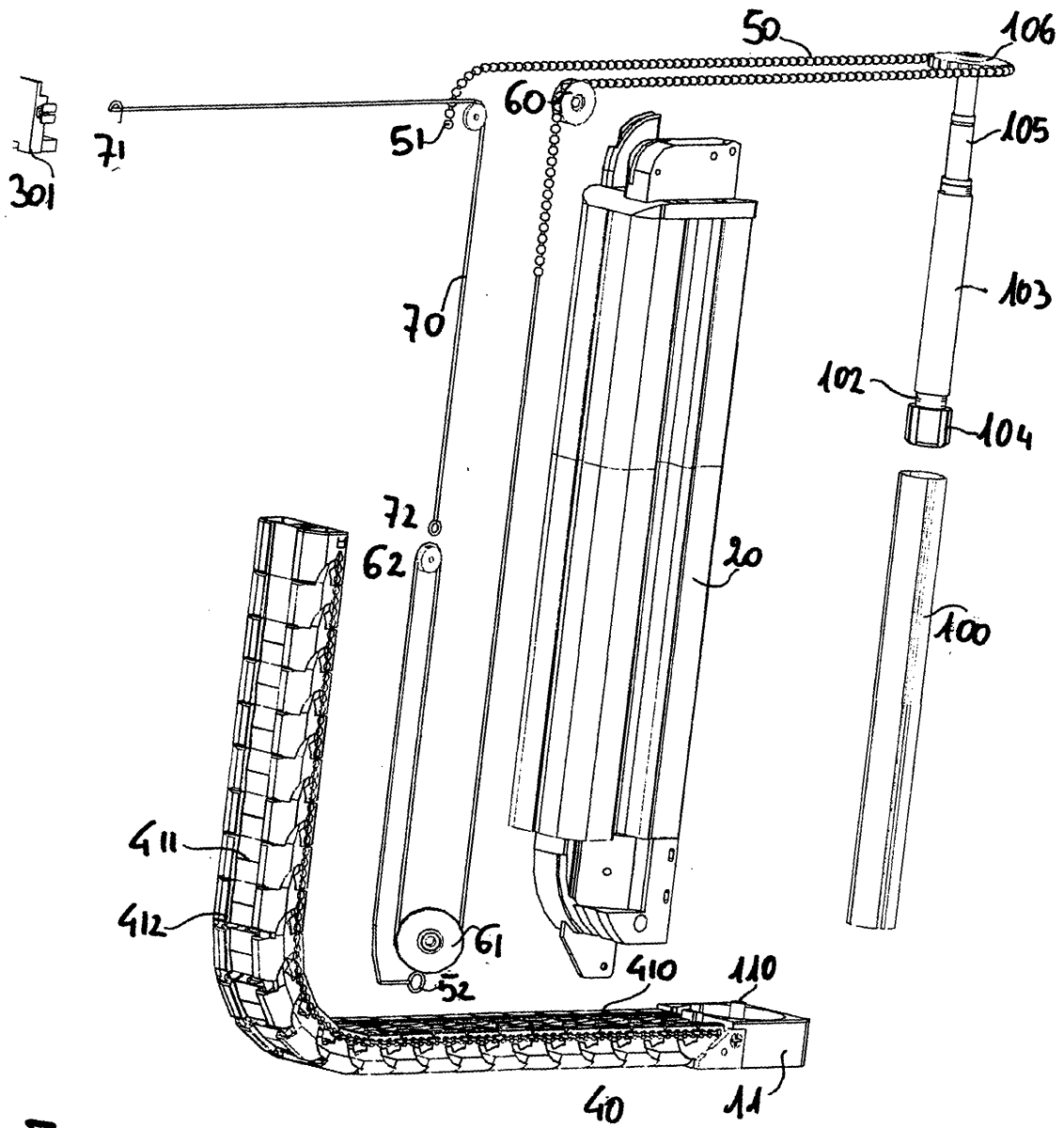

FIG. 5

REFERENCES CITED IN THE DESCRIPTION

This list of references cited by the applicant is for the reader's convenience only. It does not form part of the European patent document. Even though great care has been taken in compiling the references, errors or omissions cannot be excluded and the EPO disclaims all liability in this regard.

Patent documents cited in the description

- EP 753642 A [0007]
- EP 999335 A [0008]
- JP 53051648 A [0009]
- JP 6158961 A [0009]