

S. W. FISH.
SAFE OR VAULT.
APPLICATION FILED JAN. 12, 1910.

997,784.

Patented July 11, 1911.

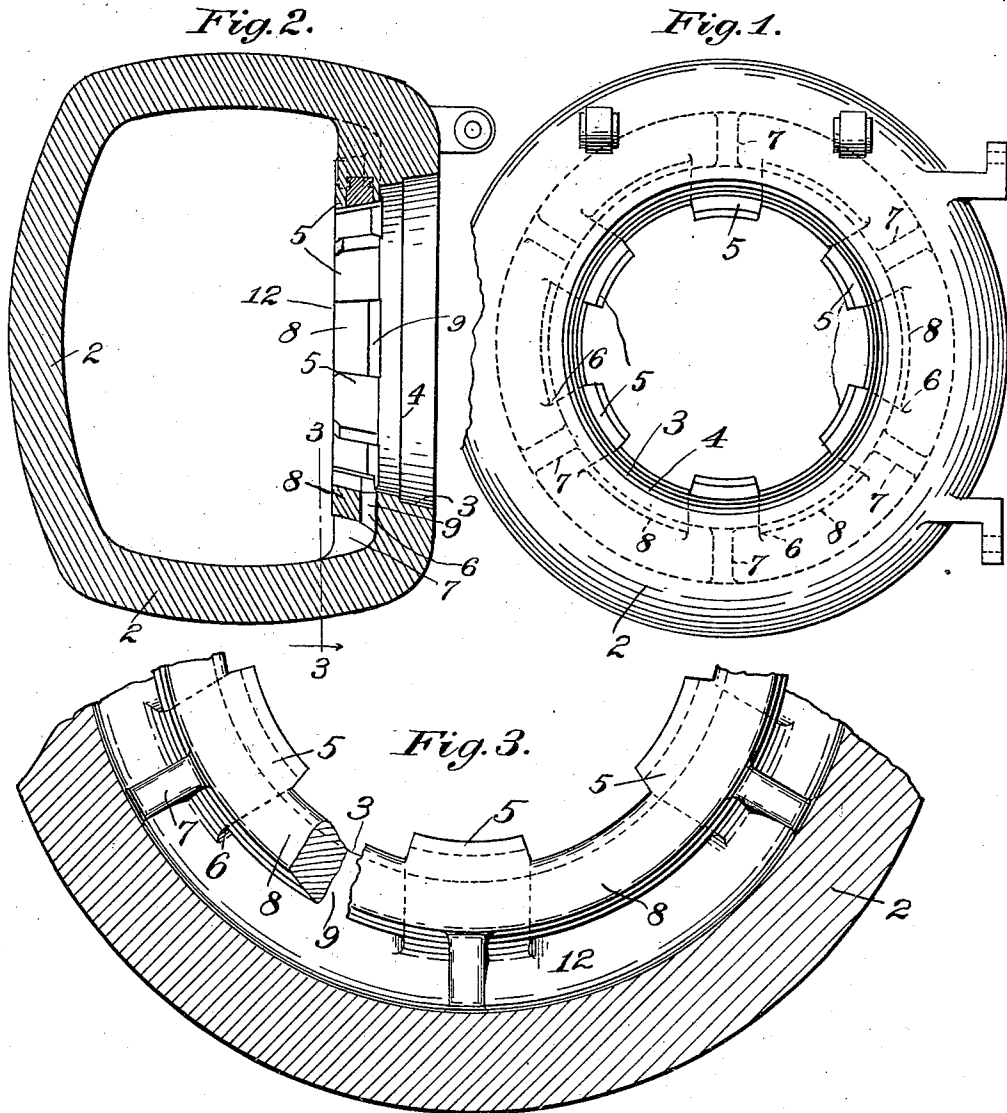

Witnesses:
W. H. Pullman
F. E. Boyce

Inventor
Samuel W. Fish.
By his Attorney
C. J. Neal

UNITED STATES PATENT OFFICE.

SAMUEL W. FISH, OF PLAINFIELD, NEW JERSEY, ASSIGNOR TO TAYLOR IRON & STEEL COMPANY, OF HIGH BRIDGE, NEW JERSEY, A CORPORATION OF NEW JERSEY.

SAFE OR VAULT.

997,784.

Specification of Letters Patent. Patented July 11, 1911.

Application filed January 12, 1910. Serial No. 537,645.

To all whom it may concern:

Be it known that I, SAMUEL W. FISH, a citizen of the United States, residing at Plainfield, in the county of Union and State of New Jersey, have invented certain new and useful Improvements in Safes or Vaults, of which the following is a specification.

This invention relates to safe or vault bodies, the object of the invention being to provide a new type of safe jamb in which the locking lugs for securing the door in position will be reinforced in a substantial manner, and reference is hereby made to my contemporaneously pending allowed applications Serial Nos. 548,487 and 548,489, filed March 10, 1910, in which different forms of the present improvement are shown.

In the drawings accompanying and forming part of this specification, Figure 1 is a front view of the safe illustrated in the present instance as turned on its side; Fig. 2 is a vertical cross-sectional view thereof; and Fig. 3 is a detail enlarged, partly sectional, view of a portion of the jamb, taken on line 3—3, Fig. 2, looking in the direction of the arrow.

Similar characters of reference indicate corresponding parts throughout the drawings.

Heretofore it has been the practice to provide a safe body with a relatively long jamb, obtained by an inwardly extending flange having a recess between it and the side wall of the body adjacent to such flange thereby to provide a substantially uniform thickness of metal around the jamb and facilitate the heat treatment of the metal. In the present instance, in order to do away with the necessity of providing this flange, the body is provided with a series of lugs spaced apart but so united with the body that it would be impracticable to separate such lugs from the body by the use of explosives or other means, while at the same time the uniformity of the metal at the jamb is maintained and the heat treatment of the structure, when made of unmachineable metal such for instance as manganese steel, not interfered with.

The safe body 2, usually cast as an integral structure and preferably of unmachineable metal such as manganese steel, is provided with a door seat 3 having a shoulder 4. Carried at the inner end of the jamb or

door seat is a series of door locking or holding lugs 5, each integral with the body and connected therewith, as at 6, by a suitable rib 7. To prevent displacement, or distortion, or separation of the lugs by explosive charges, each pair of lugs is connected by a web of metal 8 separated from the body and therefore spaced apart therefrom by an opening or channel 9, these webs together with the lugs forming an annular member entirely around the door seat.

The door locking or holding lugs may be made of various forms, as may be desired in practice.

From the foregoing it will be observed that each lug is supported at its sides by webs of metal extending to adjacent lugs and at its underside by a rib, the whole forming an integral structure with the safe body, while the uniformity of the metal around the jamb is maintained by reason of the channels or spaces 9 between the webs and the inner face 12 of the body front as well as by reason of the space between such lugs and webs and the side walls of the body, so that the passage of a suitable quenching liquid, such as water, around the lugs and the webs is not interfered with when the safe is heat treated in this manner.

I claim as my invention:

1. A safe or vault body having a plurality of integral door locking lugs, the lugs being united with each other by webs spaced apart from the body.

2. A safe or vault body having a plurality of integral door locking lugs, the lugs being united with each other by webs spaced apart from the front wall of the body.

3. A safe or vault body having a plurality of door locking lugs each united with the body by a rib and the lugs being united by webs.

4. A safe or vault body having a plurality of door locking lugs each united with the body by a rib and the lugs being united by webs spaced apart from the body to form channels therebetween.

5. A safe or vault body having a tapered door seat terminating in a series of door locking lugs integral with the body, and webs integrally uniting said lugs at the sides thereof.

6. A safe or vault body having a tapered door seat terminating in a series of door

- locking lugs integral with the body, and webs integrally uniting said lugs at the sides thereof and spaced apart from the metal of the body to form channels.
- 5 7. A safe or vault body having a tapered door seat terminating in a series of door locking lugs integral with the body, webs integrally uniting said lugs at the sides thereof and spaced apart from the metal of the body to form channels, and ribs integrally uniting the lugs with the body.
- 10 8. A safe or vault body having a tapered and shouldered door seat, and a series of lugs located around the inner terminus of the door seat and connected with each other by webs spaced apart from the metal of the body and also connected with the body by ribs located between the underside of the lugs and the body.
- 15 9. A safe or vault body having a circular door seat provided with a series of door locking lugs integrally connected with the metal of the body, and webs integrally uniting the lugs at the sides thereof and spaced apart from the body.
- 20 10. A safe or vault body having a circular door seat provided with a series of door locking lugs, ribs integrally connecting the lugs with the body, and webs integrally uniting the lugs at the sides thereof and spaced apart from the body.
- 25 11. A safe or vault body having a circular and tapered door seat or jamb, and a series of web-connected integral lugs located around such jamb, said webs being located in rear of the front wall of the body.
- 30 12. A safe or vault body having a circular and tapered door seat or jamb, and a series of web-connected and ribbed door locking lugs located in rear of such jamb.
- 35 13. A safe or vault body having a circular and tapered door seat or jamb, and a series of web-connected and ribbed door locking lugs located around such jamb, with the webs spaced apart from the metal of the body to form passages therebetween.
- 40 14. A safe or vault body provided with a circular door opening having a tapered jamb, a plurality of radially arranged ribs integrally formed on the rear face of the jamb or body front and terminating in door holding lugs projecting into the door opening, and webs connecting said door holding lugs.
- 45 15. A safe or vault body provided with a circular door opening having a tapered jamb, a plurality of radially arranged ribs integrally formed on the rear face of the jamb or body front and terminating in door holding lugs projecting into the door opening, and webs connecting said door holding lugs and spaced apart from the rear face of the jamb.
- 50 55 60

SAMUEL W. FISH.

Witnesses:

H. W. WYCKOFF,
E. NEIGHBOUR.