



Europäisches Patentamt
European Patent Office
Office européen des brevets



(11) **EP 0 894 871 B1**

(12) **EUROPEAN PATENT SPECIFICATION**

(45) Date of publication and mention
of the grant of the patent:
18.08.2004 Bulletin 2004/34

(51) Int Cl.7: **C13F 5/00**

(21) Application number: **98201721.2**

(22) Date of filing: **26.05.1998**

(54) **Apparatus for drying sugar cubes**

Einrichtung zur Trocknung von Zucker

Appareil pour le séchage du sucre

(84) Designated Contracting States:
BE DE DK ES FR GB IT NL SE

(30) Priority: **03.06.1997 NL 1006216**

(43) Date of publication of application:
03.02.1999 Bulletin 1999/05

(73) Proprietor: **Aquarius Group B.V.**
6006 RV Weert (NL)

(72) Inventors:
• **Derckx, Henricus Antonius Jacobus Maria**
3680 Maaseik (BE)
• **Torringa, Henderikus Menno**
6701 AW Wageningen (NL)

(74) Representative: **Ferguson, Alexander et al**
Octrooibureau Vriesendorp & Gaade,
P.O. Box 266
2501 AW Den Haag (NL)

(56) References cited:
EP-A- 0 036 241 **EP-A- 0 036 309**
DE-C- 924 860

- **DATABASE WPI Section Ch, Week 8716 Derwent Publications Ltd., London, GB; Class D17, AN 87-112898 XP002078731 -& JP 62 059000 A (ISHINO SEISAKUJO KK) , 14 March 1987**
- **KOHLRAUSH F.: "Praktische Physik, Vol. 2", 1985, B.G. TEUBNER, STUTTGART**

EP 0 894 871 B1

Note: Within nine months from the publication of the mention of the grant of the European patent, any person may give notice to the European Patent Office of opposition to the European patent granted. Notice of opposition shall be filed in a written reasoned statement. It shall not be deemed to have been filed until the opposition fee has been paid. (Art. 99(1) European Patent Convention).

Description

[0001] The present invention relates to an apparatus for drying sugar cubes as described in the preamble of claim 1. Such an apparatus is known from DE-C-924.860.

[0002] When producing sugar cubes, a mixture of sugar and water is pressed to the desired shape, size and weight in a press. Usually, the water content amounts to approximately 1.2% this being reduced to about 0.4% by drying in a drying device. During drying the cubes not only achieve the desired final humidity content but also the required hardness so that they can be packed in boxes. Known drying devices are hot air or infrared drying devices. Suchlike devices frequently have a high energy expenditure and are large in size; drying lines of 40 metres are no exception. If a breakdown occurs in such a known drying device, the latter will only cool down slowly after the drying device has been deactivated. As a result, not only do problems such as caramelization or discolouring of the sugar cubes arise, but in addition to that it takes longer before the failure can be put right.

[0003] It is an object of the invention to provide an apparatus for drying sugar cubes with a lower energy expenditure, in which the apparatus is also more compact and in which furthermore after deactivation, a faster cooling down of the apparatus can be realized.

[0004] For this purpose the present invention provides a device for drying sugar cubes containing a heating apparatus for heating and dehumidifying the sugar cubes, a conditioning apparatus for cooling off and possibly further dehumidifying the sugar cubes and a conveying apparatus for conveying the sugar cubes through the heating apparatus and the conditioning apparatus, in which the heating apparatus comprises a multimode microwave cavity and a number of microwave heads which are connected to the microwave cavity by their own wave-guide. Because drying the sugar cubes takes place by microwave energy generated by the microwave heads, compared to the known drying devices a homogenous heating of the whole sugar cube takes place in which most of the humidity in the sugar cube is released, thus saving between 30% and 50% of the energy. In addition, the length of the drying route can be reduced to approximately 15% compared to hot air and infrared drying. Especially because the microwave cavity is a multimode microwave cavity, that is that a number of microwave heads are provided, for instance up to 30 or more, it is possible to adjust the generated energy in an optimum manner to the sugar cubes in the microwave cavity. A further advantage of the multimode microwave cavity is that the distribution of field intensity over the width and length of the cavity can be very even, so that as a consequence all the cubes are supplied with the same amount of energy, as a result of which all the cubes have a same even temperature and humidity content at the end of the microwave cavity.

[0005] If each wave-guide is provided at the location of the microwave cavity with slots for coupling microwave energy in the microwave cavity, the field intensity can be optimally distributed in the microwave cavity, because of the size, the angle of canting and the mutual positioning of the grooves.

[0006] In an embodiment of the apparatus according to the invention each microwave head has a defined capacity, so that the field intensity in the microwave cavity can be varied accordingly.

[0007] A further embodiment of the invention according to the invention contains a sensor for detecting the number of rows of sugar cubes conveyed by the conveying apparatus into the microwave cavity, a field intensity meter for measuring the field intensity in the microwave cavity and a velocity meter for measuring the conveying velocity of the sugar cubes, as a result of which an exact adjustment and control of the drying process is obtained. A humidity sensor placed in the microwave cavity can further improve this control.

[0008] Some embodiments of a device according to the invention will, by way of example, be described on the basis of the drawing, in which

figure 1 shows a schematic side view of a device for producing and drying sugar cubes,

figure 2 shows a schematic side view of the heating apparatus according to the invention, and

figure 3 shows a schematic top view of the heating apparatus shown in figure 2.

[0009] In figure 1 a device for producing and drying sugar cubes is schematically shown in side view, which device is made in a usual line layout. Sugar and water are supplied in the usual way to a press 1, in which the sugar and the water are mixed and in which the sugar cubes are pressed into the correct shape, size and weight. From the press the sugar cubes are conveyed via a conveying apparatus 2 to the heating apparatus 3.

[0010] The heating apparatus 3 contains a multimode microwave cavity 19 (figure 2) and a number of microwave heads 10 (figure 3). The conveying apparatus 2 conveys the wet sugar cubes 13 through the microwave cavity 19, where the sugar cubes 13 are heated by microwave energy to a temperature of approximately 75°C and most of the humidity in the sugar cubes 13 is released. Because of this the sugar cubes 13 get enough latent energy to arrive at the desired final humidity content in a conditioning apparatus 4 (figure 1). After the sugar cubes have been conveyed through the conditioning apparatus 4, they are conveyed to a usual packaging apparatus 5 by the conveying apparatus 2, where the sugar cubes are packed in boxes or the like. The press 1, the conveying apparatus 2 and the packaging apparatus 5 are electrically driven in the known manner, the drives being adapted to one another.

[0011] In order that as little microwave energy as possible is lost in the microwave cavity, the conveying apparatus 2 is preferably a conveyor belt made of synthetic material, the dielectric characteristics of which being such, that the conveyor belt takes up as little energy as possible.

[0012] The heating apparatus 3 contains a number of microwave heads 10 which are connected to the microwave cavity by their own wave-guide 17 (figure 3). In the embodiment shown in the figures, the wave-guides are placed horizontally, transverse to the direction of conveyance, with the microwave heads at the ends of the wave-guides. Alternatively, the microwave heads can be placed directly under the stream of sugar cubes, the microwave heads being connected with vertical wave-guides to the microwave cavity. This last alternative embodiment provides a more compact construction form and a good heating of the sugar cubes, which is almost independent of the height of the sugar cubes. In addition, in the exemplary embodiment shown in the figures, the number of microwave heads is five, although in practice up to thirty or more heads can be used. The microwave heads are, for instance, are standard industrial heads with a capacity of 1.2 kW, for example.

[0013] Each wave-guide 17 is provided at the location of the microwave cavity with slots 18 for coupling the microwave energy in the microwave cavity. The size, position and mutual positioning of the slots 18 can be chosen to obtain a desired field intensity distribution in the microwave cavity. Furthermore, each microwave head has a defined capacity, or an independent capacity adjustment in order to further distribute the field intensity as desired.

[0014] Because the microwave heads are independently adjustable, the action of the inventive drying device is improved with regard to the known devices, namely in startup and stop situations. When starting up the inventive device, the microwave cavity will slowly be filled with sugar cubes. In order to obtain a uniform drying process, in accordance with this several microwave heads are switched on upon starting up or more capacity is generated by the microwave heads. An adjustment of this kind can be controlled by the sensor 12 at a known conveying velocity. In a stop situation, for instance when there is a breakdown, the energy supply to the microwave heads can be switched off immediately, as a result of which heating does not take place either. The microwave cavity then cools off immediately. Problems such as caramelization or discolouring do not therefore occur and repairs can be speedily carried out.

[0015] In the microwave cavity 19 there are means, for example one or more ventilators 14, for extracting from the microwave cavity air in which humidity is included which is already leaving the sugar cubes 13. In order to improve air circulation, the conveyor belt is provided with air passages.

[0016] A sensor 12 detects the number of rows of sugar cubes conveyed by the conveyor belt 2 into the mi-

crowave cavity, a field intensity meter 16 measures the field intensity in the microwave cavity 19 and, together with the velocity of the conveyor belt 2 measured by the velocity meter, the microwave heads are switched on or off so as to obtain a field intensity distribution desirable under the detected circumstances. The advantage of a multimode microwave cavity having suchlike adjustment, compared to using one large microwave source, is that an exact control of the drying process is obtained. A further improvement of the control of the drying process can be obtained by including a humidity sensor in the microwave cavity.

[0017] A further advantage of a multimode microwave cavity is that there is a uniform distribution of the field intensity over the width and length of the microwave cavity, which results in the supply to all sugar cubes of the same quantity of energy, so that at the end of the microwave cavity all the sugar cubes have an equal temperature and an equal humidity content. As a consequence, all the sugar cubes will eventually have the same residual humidity content and the same hardness, which is important for packaging and further storage of the sugar cubes.

[0018] In order to prevent undesired microwave energy from leaving the heating apparatus 3, the latter is provided with protective devices 15.

[0019] After the sugar cubes have passed through the microwave cavity, they are conveyed by the conveyor belt to and through the conditioning apparatus, where the sugar cubes are cooled by means of cooling means for generating air circulation. In addition, this air ensures the discharge of the humidity which may be leaving the sugar cubes. In that way the sugar cubes obtain the desired final humidity content and the desired hardness.

[0020] Given that the microwave heads are cooled by air, this air is heated. This heated air can be led to the microwave cavity of the heating apparatus by means of tubes. The thermal energy of this air is then used for additional heating of the sugar cubes, this heated air also discharging humidity released in the microwave cavity and preventing condensation in the microwave cavity.

[0021] With the drying device according to the invention a drying process which is 85% faster in comparison to known drying devices is obtained, with an energy saving of 30 to 50%. Moreover, the floor surface required by the device is considerably reduced.

50 Claims

1. Apparatus for producing and drying sugar cubes to the desired final humidity content comprising:

a press for producing the sugar cubes;
a heating apparatus (3) for heating and dehumidifying a plurality of sugar cubes, said heating apparatus being placed downstream of said

press;

a conditioning apparatus (4) for cooling said plurality of sugar cubes;

a conveying apparatus (2) for conveying said sugar cubes from said press and through said heating apparatus and said conditioning apparatus, **characterized in that** said heating apparatus (3) includes a multimode microwave cavity (19) and a plurality of microwave heads (10), each of said microwave heads connected to said same microwave cavity by its own waveguide (17), each microwave head being independently adjustable.

2. Apparatus for producing and drying sugar cubes according to claim 1, in which each wave-guide (17) is provided at the location of the microwave cavity with slots (18) for coupling microwave energy in the microwave cavity.
3. Apparatus for producing and drying sugar cubes according to claim 1 or 2, in which each microwave head has a defined capacity.
4. Apparatus for producing and drying sugar cubes according to claim 1, 2 or 3, in which the microwave cavity (19) contains means (14) for discharging air and moisture out of there.
5. Apparatus for producing and drying sugar cubes according to any one of the preceding claims, in which the device is provided with a sensor (12) for detecting the number of rows of sugar cubes conveyed by the conveying apparatus into the microwave cavity (19), a field intensity meter (16) for measuring the field intensity in the microwave cavity and a velocity meter for measuring the conveying velocity of the sugar cubes.
6. Apparatus for producing and drying sugar cubes according to any one of the preceding claims, in which the microwave cavity (19) is provided with a humidity sensor.
7. Apparatus for producing and drying sugar cubes according to any one of the preceding claims, in which the conditioning apparatus (4) is provided with cooling means for cooling the sugar cubes by means of air circulation.
8. Apparatus for producing and drying sugar cubes according to any one of the preceding claims, in which the conveying apparatus (2) is a conveying belt made of synthetic material which absorbs almost no microwave energy.
9. Apparatus for producing and drying sugar cubes according to claim 8, in which the conveyor belt (2) is

provided with air passages.

10. Apparatus according to any one of the preceding claims, wherein the microwave heads (10) are placed directly under the stream of sugar cubes, the microwave heads (10) being connected with vertical waveguides to the microwave cavity.

10 Patentansprüche

1. Vorrichtung zum Produzieren und Trocknen von Würfeln Zucker bis den gewünschten Endfeuchtigkeitsgehalt, umfassend:
 - eine Presse zum Produzieren der Würfel Zucker;
 - eine Heizvorrichtung (3) zum Erwärmen und Entfeuchten einer Vielzahl von Würfeln Zucker, wobei die Heizvorrichtung stromabwärts der Presse angeordnet ist;
 - eine Konditionierungsvorrichtung (4) zum Kühlen der Vielzahl von Würfeln Zucker;
 - eine Fördervorrichtung (2) zum Fördern der Würfel Zucker von der Presse und durch die Heizvorrichtung und die Konditionierungsvorrichtung, **dadurch gekennzeichnet, daß** die Heizvorrichtung (3) einen Mehrmoden Mikrowellenhohlraum (19) und eine Vielzahl von Mikrowellenköpfen (10) umfaßt, wobei jeder Mikrowellenkopf durch seinen eigenen Wellenleiter (17) auf demselben Mikrowellenhohlraum angeschlossen ist, wobei jeder Mikrowellenkopf unabhängig einstellbar ist.
2. Vorrichtung zum Produzieren und Trocknen von Würfeln Zucker nach Anspruch 1, wobei jeder Wellenleiter (17) an Ort und Stelle des Mikrowellenhohlraums mit Nuten (18) zum Koppeln von Mikrowellenenergie in dem Mikrowellenhohlraum versehen ist.
3. Vorrichtung zum Produzieren und Trocknen von Würfeln Zucker nach Anspruch 1 oder 2, wobei jeder Mikrowellenkopf eine bestimmte Kapazität hat.
4. Vorrichtung zum Produzieren und Trocknen von Würfeln Zucker nach Anspruch 1, 2 oder 3, wobei der Mikrowellenhohlraum (19) Mittel (14) zum Abführen von Luft und Feuchtigkeit daraus umfaßt.
5. Vorrichtung zum Produzieren und Trocknen von Würfeln Zucker nach einem der vorhergehenden Ansprüche, wobei die Vorrichtung mit einem Sensor (12) zum Detektieren der Anzahl von durch die Fördervorrichtung in den Mikrowellenhohlraum (19) geförderten Reihen von Würfeln Zucker, mit einem Feldintensitätsmesser (16) zum Messen der Feld-

stärke in dem Mikrowellenhohlraum und mit einem Geschwindigkeitsmesser zum Messen der Fördergeschwindigkeit der Würfel Zucker, versehen ist.

6. Vorrichtung zum Produzieren und Trocknen von Würfeln Zucker nach einem der vorhergehenden Ansprüche, wobei der Mikrowellenhohlraum (19) mit einem Feuchtigkeitssensor versehen ist. 5
7. Vorrichtung zum Produzieren und Trocknen von Würfeln Zucker nach einem der vorhergehenden Ansprüche, wobei die Konditionierungsvorrichtung (4) mit Kühlmitteln zum durch Luftzirkulation Kühlen der Würfel Zucker versehen ist. 10
8. Vorrichtung zum Produzieren und Trocknen von Würfeln Zucker nach einem der vorhergehenden Ansprüche, wobei die Fördervorrichtung (2) einen aus Kunststoffmaterial hergestellten Förderband ist, der fast keine Mikrowellenenergie absorbiert. 15
9. Vorrichtung zum Produzieren und Trocknen von Würfeln Zucker nach Anspruch 8, wobei der Förderband (2) mit Luftdurchlaßöffnungen versehen ist. 20
10. Vorrichtung nach einem der vorhergehenden Ansprüche, wobei die Mikrowellenköpfe (10) direkt unter dem Strom von Würfeln Zucker angeordnet sind, wobei die Mikrowellenköpfe (10) mit vertikalen Wellenleitern mit dem Mikrowellenhohlraum verbunden sind. 25

Revendications 30

1. Appareil pour produire des morceaux de sucre et les sécher jusqu'à obtention de la teneur finale en humidité souhaitée, comprenant: 35

une presse pour produire les morceaux de sucre;

un appareil de chauffage (3) pour chauffer et déshumidifier une pluralité de morceaux de sucre, ledit appareil de chauffage étant placé en aval de ladite presse; 40

un appareil de conditionnement (4) pour refroidir ladite pluralité de morceaux de sucre;

un appareil transporteur (2) pour transporter lesdits morceaux de sucre depuis ladite presse et leur faire traverser ledit appareil de chauffage et ledit appareil de conditionnement; 45

caractérisé en ce que ledit appareil de chauffage (3) comprend une cavité micro-ondes multimodale (19). et une pluralité de magnétrons (10), chacun desdits magnétrons étant relié à la même cavité micro-ondes par son propre guide d'on-

des (17) et chaque magnétron étant ajustable de façon indépendante.

2. Appareil pour produire des morceaux de sucre et les sécher selon la revendication 1, dans lequel chaque guide d'ondes (17) est pourvu à l'emplacement de la cavité micro-ondes de fentes (18) pour accoupler de l'énergie micro-onde dans la cavité micro-ondes.

3. Appareil pour produire des morceaux de sucre et les sécher selon la revendication 1 ou 2, dans lequel chaque magnétron a une capacité déterminée.

4. Appareil pour produire des morceaux de sucre et les sécher selon la revendication 1, 2 ou 3, dans lequel la cavité micro-ondes (19) est pourvue des moyens (14) pour en évacuer l'air et l'humidité. 15

5. Appareil pour produire des morceaux de sucre et les sécher selon l'une quelconque des revendications précédentes, dans lequel le dispositif est pourvu d'un capteur (12) pour détecter le nombre de rangées de morceaux de sucre transportées par l'appareil transporteur dans la cavité micro-ondes (19), un appareil de mesure de l'intensité du champ (16) pour mesurer l'intensité du champ dans la cavité micro-ondes et un vélocimètre pour mesurer la vitesse de transport des morceaux de sucre. 20

6. Appareil pour produire des morceaux de sucre et les sécher selon l'une quelconque des revendications précédentes, dans lequel la cavité micro-ondes (19) est pourvue d'un capteur d'humidité. 25

7. Appareil pour produire des morceaux de sucre et les sécher selon l'une quelconque des revendications précédentes, dans lequel l'appareil de conditionnement (4) est pourvu de moyens de refroidissement pour refroidir les morceaux de sucre au moyen d'une circulation d'air. 30

8. Appareil pour produire des morceaux de sucre et les sécher selon l'une quelconque des revendications précédentes, dans lequel l'appareil transporteur (2) est un tapis roulant fabriqué dans un matériau synthétique que n'absorbe presque pas d'énergie micro-ondes. 35

9. Appareil pour produire des morceaux de sucre et les sécher selon la revendication 8, dans lequel le tapis roulant (2) est pourvu de passages pour l'air. 40

10. Appareil pour produire des morceaux de sucre et les sécher selon l'une quelconque des revendications précédentes, dans lequel les magnétrons (10) sont placés directement sous l'écoulement des morceaux de sucre, les magnétrons (10) étant re-

liés à la cavité micro-ondes par des guides d'ondes
verticaux.

5

10

15

20

25

30

35

40

45

50

55

6

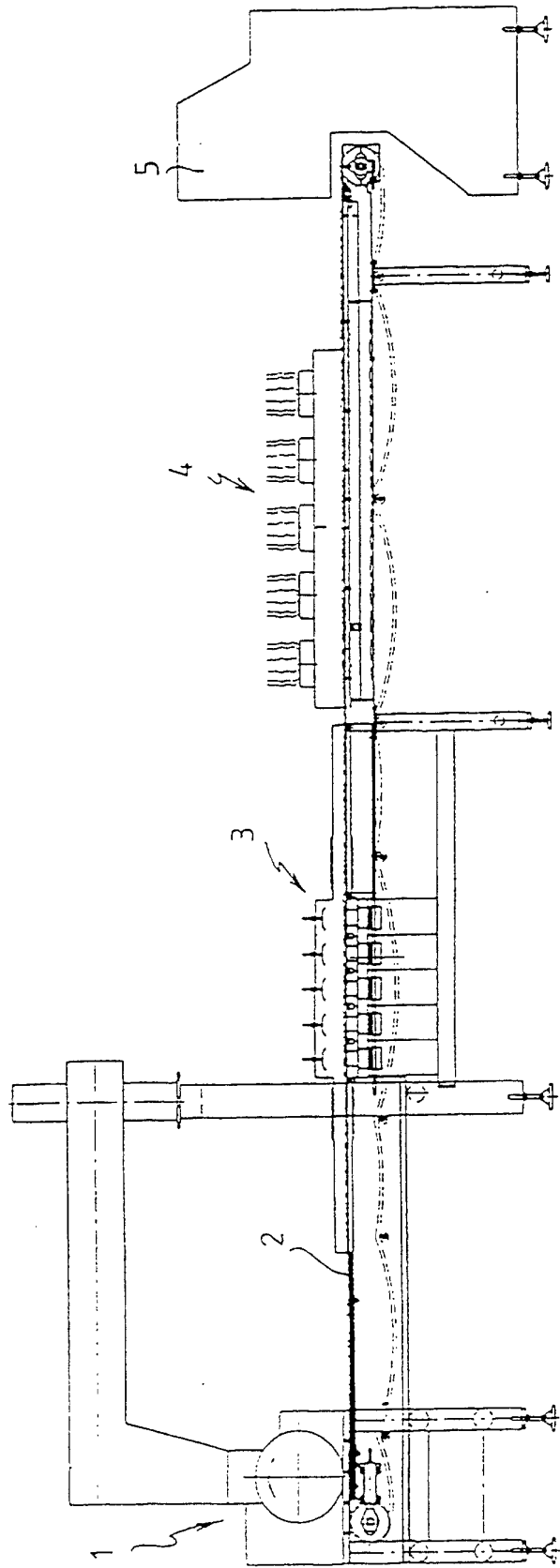

FIG. 1

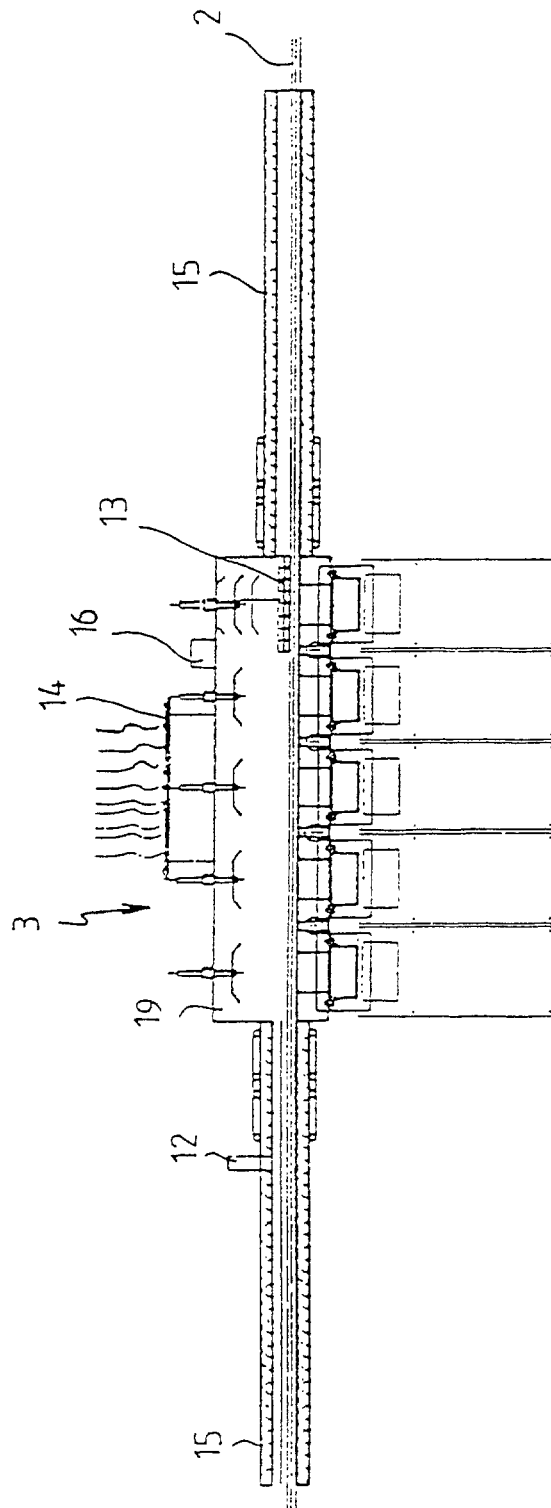

FIG. 2

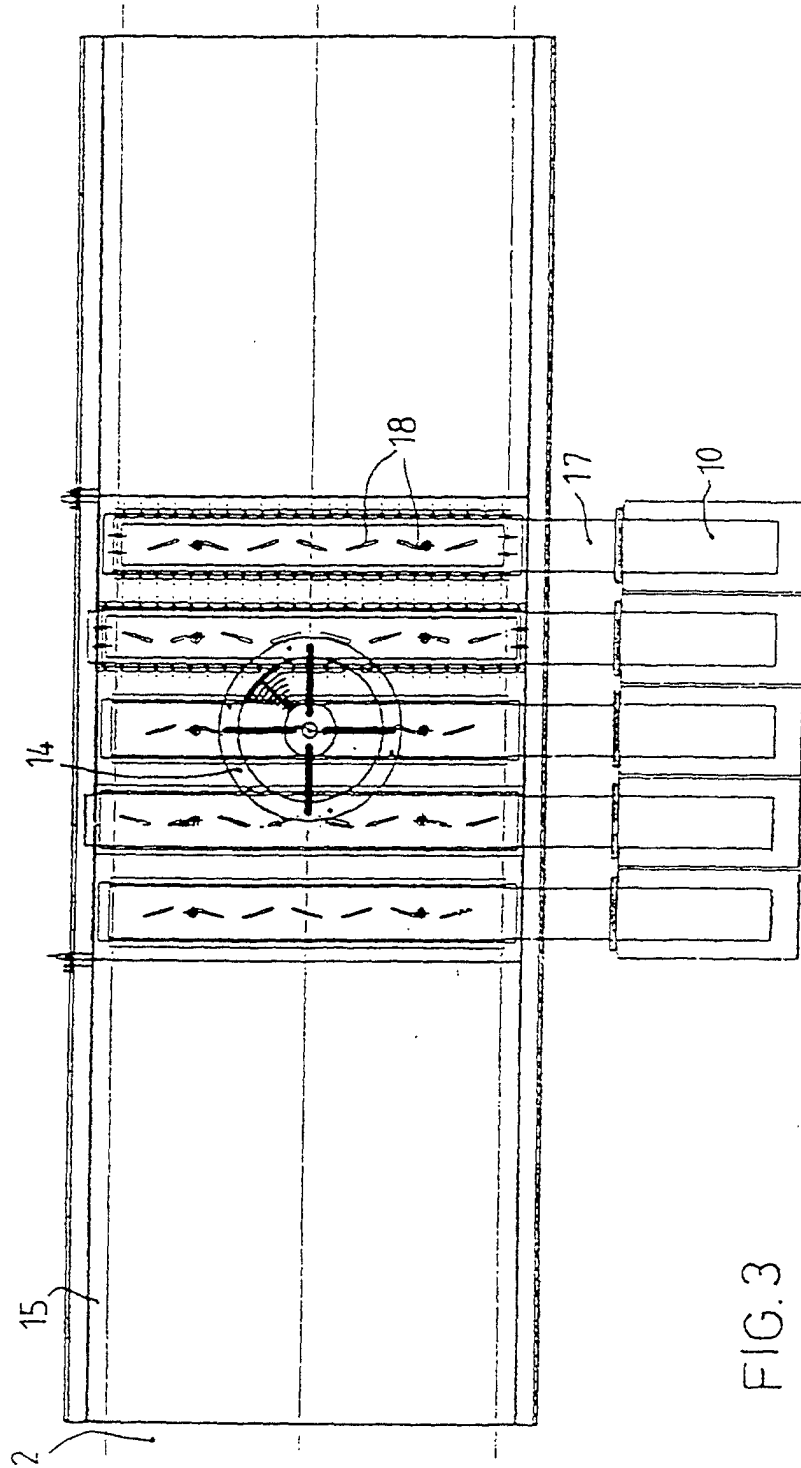

FIG.3