



- (51) International Patent Classification:  
A01F 15/08 (2006.01) A01B 61/02 (2006.01)
- (21) International Application Number:  
PCT/EP2014/057607
- (22) International Filing Date:  
15 April 2014 (15.04.2014)
- (25) Filing Language: English
- (26) Publication Language: English
- (30) Priority Data:  
BE2013/0272 15 April 2013 (15.04.2013) BE
- (71) Applicant (for all designated States except US): CNH INDUSTRIAL BELGIUM NV [BE/BE]; Leon Claeyssstraat 3A, B-8210 Zedelgem (BE).
- (71) Applicant (for US only): CNH INDUSTRIAL AMERICA LLC [US/US]; P.O. Box 1895, 500 Diller Avenue, New Holland, Pennsylvania 17557 (US).
- (72) Inventor: BONTE, Xavier; Wilhelminaweg 38, NL-4528 Et Sint Kruis (NL).
- (74) Agent: VAN BALLAER, Evi M.A.; CNH Industrial Belgium nv, Leon Claeyssstraat 3A, B-8210 Zedelgem (BE).

(81) Designated States (unless otherwise indicated, for every kind of national protection available): AE, AG, AL, AM, AO, AT, AU, AZ, BA, BB, BG, BH, BN, BR, BW, BY, BZ, CA, CH, CL, CN, CO, CR, CU, CZ, DE, DK, DM, DO, DZ, EC, EE, EG, ES, FI, GB, GD, GE, GH, GM, GT, HN, HR, HU, ID, IL, IN, IR, IS, JP, KE, KG, KN, KP, KR, KZ, LA, LC, LK, LR, LS, LT, LU, LY, MA, MD, ME, MG, MK, MN, MW, MX, MY, MZ, NA, NG, NI, NO, NZ, OM, PA, PE, PG, PH, PL, PT, QA, RO, RS, RU, RW, SA, SC, SD, SE, SG, SK, SL, SM, ST, SV, SY, TH, TJ, TM, TN, TR, TT, TZ, UA, UG, US, UZ, VC, VN, ZA, ZM, ZW.

(84) Designated States (unless otherwise indicated, for every kind of regional protection available): ARIPO (BW, GH, GM, KE, LR, LS, MW, MZ, NA, RW, SD, SL, SZ, TZ, UG, ZM, ZW), Eurasian (AM, AZ, BY, KG, KZ, RU, TJ, TM), European (AL, AT, BE, BG, CH, CY, CZ, DE, DK, EE, ES, FI, FR, GB, GR, HR, HU, IE, IS, IT, LT, LU, LV, MC, MK, MT, NL, NO, PL, PT, RO, RS, SE, SI, SK, SM, TR), OAPI (BF, BJ, CF, CG, CI, CM, GA, GN, GQ, GW, KM, ML, MR, NE, SN, TD, TG).

Published:  
— with international search report (Art. 21(3))

(54) Title: FLYWHEEL STARTUP SYSTEM.

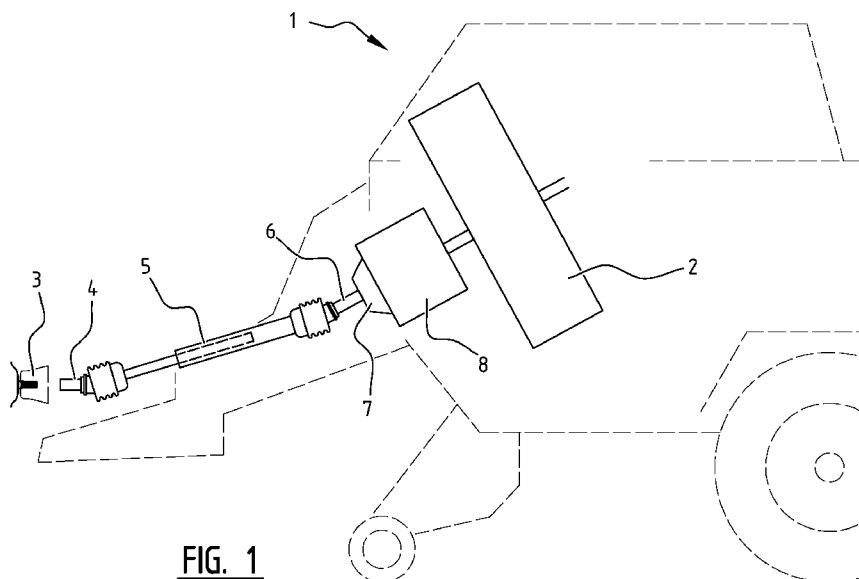

FIG. 1

(57) Abstract: An agricultural baler comprising a flywheel that is connected via a cardan coupling to a PTO of a tractor, the cardan coupling comprising a torque-limiter adapted for disengaging the flywheel from the PTO when a predetermined torque is exceeded, wherein the cardan coupling further comprises transmission means that are switchable between a startup state and a running state, in the startup state the transmission means being configured to only partially transmit rotational movement of the PTO to the flywheel while in the running state the transmission means being configured to fully transmit rotational movement of the PTO to the flywheel.

WO 2014/170318 A1

### Flywheel startup system

The present invention relates to an agricultural baler. More particularly, the present invention relates to an improved cardan coupling for an agricultural baler.

Agricultural balers typically comprise a flywheel. A flywheel is provided as a buffer between the continuous power supply of the tractor and the pulsed power consumption of the baler mechanics. Over the years, balers have become more and more powerful, meaning that larger bales can be compressed to a higher density. This requires a large amount of power to be transmitted from the tractor to the mechanics. Therefore, modern balers tend to have large and heavy flywheels.

A drawback from large and heavy flywheels is that it requires a lot of energy to accelerate the flywheel from a standing still state to a working state. Typically a flywheel rotates at about 1000 rpm (rotations per minute) in a conventional working state. The flywheel is typically connected to a PTO (power take off) of a tractor via a cardan coupling. Although the latest generation tractors might be constructed to be able to startup a heavy large flywheel, most older tractors don't. When such large and heavy flywheel is connected to a tractor that is not adapted to handle such flywheel, the tractor is stalled and the flywheel can not be started.

Suggestions have been made in the prior art to rotate a flywheel via a hydraulic system. However, such hydraulic systems are costly and complex in use.

It is an object of the present invention to provide an agricultural baler that is adapted to transmit high

powers from PTO to the baler mechanics while preventing stalling of the tractor during startup.

To this end, the agricultural baler according to  
5 the invention comprises a flywheel that is connected via a  
cardan coupling connector that is provided to connected to a  
PTO of a tractor, so that the flywheel can be driven by the  
PTO, the cardan coupling comprising a torque-limiter adapted  
for at least partially disengaging the flywheel from the PTO  
10 when a predetermined torque is exceeded, characterized in  
that the cardan coupling further comprises transmission  
means that are switchable between a startup state and a  
running state, in the startup state the transmission means  
being configured to only partially transmit rotational  
15 movement of the PTO to the flywheel while in the running  
state transmission means are configured to fully transmit  
rotational movement of the PTO to the flywheel. In the  
invention, the cardan coupling comprises, besides a torque-  
limiter, a transmission means that is switchable between the  
20 startup state and a running state. The torque-limiter is  
added for security purposes to disengage when the torque  
transmitted through the cardan coupling exceeds a  
predetermined torque. The predetermined torque is chosen so  
that the different element in the cardan coupling are  
25 protected against overload. The transmission means are  
switchable between a startup state and a running state. In  
the running state, the transmission means fully transmit  
rotational movement of the PTO to the flywheel. Thereby in  
the running state, the transmission means is comparable to a  
30 conventional axle. In the startup state, the transmission  
means only partially transmit rotational movement of the PTO  
to the flywheel. As a result, the PTO can have a higher  
rotational speed than the flywheel. Since the PTO is  
conventionally connected to a combustion engine of the  
35 tractor, the PTO typically requires a minimum rotational  
speed to be able to exert a significant torque. When the

transmission means are in the startup state, the PTO is allowed to have a higher rotational speed than the flywheel. As a result, the tractor is not stalled since the rotational speed can be maintained above the minimum rotational speed of the tractor. According to the invention, no expensive hydraulic systems are required for starting or powering the flywheel. Yet because of the transmission means, a flywheel can be provided in the baler that is too heavy and/or big to start via a direct connection.

10

Preferably the transmission means are formed as a gearbox. A gearbox typically has an input and an output shaft. The gearbox is thereby provided to adapt the rotational speed between the input and output shafts. Gearboxes can have multiple gears and can shift between the multiple gears to change the rotational speed ratio between input and output shafts.

15

Preferably the gearbox is a planetary gearbox. Planetary gearboxes are available in the market and are known to be reliable. Furthermore, using a planetary gearbox has as an advantage that the input shaft axis coincides with the output shaft axis so that the gearbox can be easily mounted in a cardan coupling.

25

Preferably, in the running state, the gearbox transmits the rotation from PTO to flywheel in a one-to-one ratio while in the startup state, the gearbox transmits the rotation from PTO to flywheel in a N-to-one ratio, whereby N is larger than 1. Thereby, the gearbox has two gears, the first gear is used in the running state and directly transmits the rotational movement of the input to the output. In the other gear, which is used in the startup state, the flywheel rotational speed is decreased with respect to the PTO rotational speed. As a result, a leverage is created for starting up and accelerating the flywheel.

35

Alternatively, according to another embodiment, the transmission means are formed as a clutch. A clutch has three operating stages, a disengaged state, a slipping stage, and an engaged stage. During the startup of the flywheel, the clutch can be held in the slipping stage so that the rotational movement of the PTO is only partially transmitted to the flywheel (due to the slip). In the running state, the clutch can be set in the engaged state so that the rotational movement is fully transmitted to the clutch. In this manner, the flywheel can be accelerated without the flywheel stalling the tractor.

Preferably, the clutch is fluid cooled. Particularly when accelerating heavy and big flywheels, the energy that is transmitted through the clutch is high. When the clutch is slipping during startup of the flywheel, a significant amount of heat is generated. By cooling the clutch using fluid, the heat can be efficiently abducted.

Preferably the clutch is a friction clutch. A friction clutch is known to be able to transmit high powers.

Preferably the clutch comprises multiple discs. In a multiple disc clutch, the energy that is transmitted through the clutch is divided over the multiple discs. Therefore such multiple disc clutch is advantageous when high powers are transmitted through the clutch.

Preferably in the running state, the clutch is adapted to be fully engaged so that rotation from PTO to flywheel is fully transmitted, while in the startup state the clutch is adapted to be partially engaged (allowing slipping) so that the rotation from PTO to flywheel is only partially transmitted. Via the slipping of the clutch, the tractor can be prevented from stalling.

Preferably, the torque-limiter is integrally formed within the transmission means. In the case of a gearbox, a shearing bolt can be provided in or at the gearbox that is used as a torque-limiter. In the case of a clutch, the torque-limiter can be formed by the disengaged stage of the clutch, where the PTO is disconnected from the flywheel.

Preferably, the flywheel has a predetermined rotational speed when the baler is in operation and wherein the transmission means are configured to be in the startup state when the flywheel is rotating from 0 to 30% from the predetermined rotational speed. Preferably, the transmission means are configured to be in the startup state when the flywheel is rotating from 0 to 50% of the predetermined rotational speed. Tests have shown that the tractor only tends to stall when the rotating speed is low (0 to 20%, 0 to 30%, or 0 to 40% of the normal rotational speed). By configuring the transmission means to be in the startup state while the rotational speed of the flywheel is low (from the point of view of the tractor), stalling of the tractor is prevented.

Preferably the transmission means are controlled by a controller that is operationally connected to the tractor. Thereby, tractor conditions and settings can be used to control the state of the transmission means. For example, when stalling of the tractor is detected (in an early stage), the transmission means can be switched to the startup state to prevent further stalling of the tractor.

Preferably the controller is provided to instruct the transmission means to switch states. Thereby, the controller can control the transmission means.

The invention will now be described in more details with respect to the figures illustrating some preferred embodiments of the invention. In the figures:

Figure 1 shows a schematic representation of a baler having a flywheel and a cardan coupling for connecting the flywheel to the PTO of a tractor;

Figure 2 shows a clutch that can be used as transmission means;

Figure 3 shows a gearbox that can be used as transmission means;

Figure 4 shows a graph showing the startup rotation speed of PTO and flywheel with a gearbox as transmission means; and

Figure 5 shows a graph showing the startup rotation speed of PTO and flywheel when a clutch is used as transmission means.

In the figures a same reference number has been allocated to a same or analogous element.

Figure 1 shows a baler 1 having a flywheel 2. The flywheel 2 is connectable to the PTO 3 of a tractor. Thereby, the flywheel 2 can be driven by the PTO 3 of the tractor. To this end, the flywheel 2 is connected via a cardan coupling to the PTO 3. The cardan coupling comprises a connector 4 which is adapted to be connected to the PTO 3. Cardan coupling further comprises primary shaft 5 and a secondary shaft 6 which are mounted under an angle with respect to one another, and whereby the primary shaft is typically telescopic. The cardan coupling furthermore comprises a torque-limiter 7. The torque-limiter 7 can be formed by a shear bolt mechanism, a clutch mechanism or another torque-limiting mechanism. The cardan coupling furthermore comprises a transmission means 8 which will be further described in more detail.

The transmission means 8 are adapted to facilitate starting up the flywheel 2. In operation of the agricultural baler, the flywheel rotates at a speed of around 1000 rpm (rotations per minute). It will be clear that other rotational speeds of the baler 1 are also possible. The flywheel 2 has a high inertia. The flywheel is intended to have a high inertia for the purpose of providing the huge energy peak for the plunger & flattening out the pulsed power consumption of baler mechanisms. However, in the startup procedure of the baler, accelerating the flywheel with high inertia requires a lot of energy. In practice, when the flywheel is standing still or at very low speed, some tractors do not have the power to accelerate the flywheel 2 via a direct connection. The transmission means are provided to switch between a startup state and a running state. In the startup state, the rotation is not directly connected from PTO to flywheel. As a result, the PTO can rotate at a higher rotational speed than the flywheel 2, thereby facilitating the acceleration of the flywheel and preventing stalling of the tractor. In the running state, the transmission means do directly transmit the rotational speed from the PTO to the flywheel 2 so that a conventional operation is possible once the flywheel has been accelerated.

25

Figure 2 shows an example of a transmission means. Figure 2 shows a fluid cooled multiple disc clutch. The clutch is mounted in a housing 9, and shows an input shaft 11 and an output shaft 12. The output shaft 12 is connected to the flywheel 2, while the input shaft 11 is connected to the PTO 3. The clutch comprises multiple discs 10, half of the discs being connected to the input shaft 11 and the other half of the discs being connected to the output shaft 12. Thereby, the discs 10 can be compressed together by an actuator so that the discs frictionally engage with one another thereby engaging the input shaft and the output

35

shaft 11, 12. When the actuator is released, the discs 10 disengage from one another so that the connection between the input shaft 11 and the output shaft 12 is disengaged (there is no connection). Besides the fully engaged and fully disengaged state, the clutch has a slipping state wherein the actuator partly compresses the plates 10 to one another. In the slipping state, the input shaft 11 and output shaft 12 do not rotate at the same speed and yet a torque can be transmitted from the input shaft 11 to the output shaft 12. This torque is transmitted by friction between the discs. In such slipping state, a lot of heat is generated, and therefore, the clutch is preferably fluid cooled, for example by oil. Fluid cooled multiple disc clutches are known in the art, and are therefore not further described in more detail. It will be clear to the skilled person that a dry friction clutch can also be used as transmission means, and that the invention is not limited to the clutch details.

Figure 3 shows a gearbox that can be used as transmission means 8. The gearbox shows a housing 9 which is preferably mounted to the baler in a fixed position. The gearbox further comprises an input shaft 11 and an output shaft 12. According to the example shown in figure 3, the input shaft 11 is connected to the center wheel (sun gear) 13 of the planetary gearbox. The output shaft 12 is connected to the carrier of planet wheels 14 of the planetary gearbox. Planetary gearbox further comprises a ring gear 15. The planetary gearbox further comprises shift clutch for direct connection 16 and shift clutch for reduced speed 17. The shift clutch for direct connection is situated between the center wheel and the planetary wheels, to block their relative position thereby directly transmitting a rotation from the center wheel (connected to the input shaft 11) to the carrier of planet wheels 14 (which is connected to the output shaft 12), thereby directly transmitting the

rotation from input shaft 11 to output shaft 12. The shift clutch for reduced speed is situated between the ring wheel 15 and the housing 9. When this shift clutch is engaged, the ring wheel stands still with respect to the housing 9, and thereby rotation of the center wheel 13 of a first rotational speed will have as a result that the carrier of planet wheels 14 will rotate at another rotational speed (which in this example is reduced with respect to the center wheel rotational speed). Thereby, rotation is transmitted at a reduced speed from input shaft 11 to output shaft 12. In the running state, the shift clutch for direct connection is engaged so that the rotational movement is transmitted from the input shaft 11 to the output shaft 12 in a one-to-one ratio. In the startup state, the rotational movement is transmitted from the input shaft 11 to the output shaft 12 in a N-to-one ratio. Thereby, the gearbox is preferably constructed so that N is situated between 1.5 and 4, more preferably between 2 and 3. It will be clear to a skilled person that although a planetary gearbox is shown in figure 3, other gearboxes can be used as transmission means.

Figure 4 shows a graph wherein the rotational speed of PTO and flywheel are shown during startup of the flywheel when a gearbox is used as transmission means. The figure shows a first section where (at the left hand side of the graph) the PTO rotational speed increases N times more than the flywheel rotational speed. This allows the PTO to quickly pick up speed so that stalling of the tractor can be prevented. Furthermore, acceleration of the flywheel is made more easy in the first stage because of the reduction effect of the gearbox. In a second stage, the gearbox shifts to a direct connection, and the flywheel and PTO show the same rotational speed. A direct connection at this point of the startup procedure typically does not negatively affect the tractor because the PTO rotational speed is brought back to the operational rotational speed divided by N (in this

example around 500 rpm). At this rotational speed, the tractor already generates a significant high torque force, thereby being able to further accelerate the flywheel until it reaches the operational rotational speed (in this example  
5 1000 rpm).

Figure 5 shows a similar graph showing PTO and flywheel rotational speeds during startup when a clutch is used as transmission means. The clutch is preferably so  
10 controlled that the PTO in a first stage rotates at a rotational speed that is about constant. Thereby, the rotational speed of the PTO is chosen to be a rotational speed where the tractor generates a significantly high torque force (that is higher than the flywheel rotational  
15 speed). Thereby, the clutch slips and thereby transmits the torque to the flywheel so that the flywheel can accelerate. In a second stage of the startup procedure, particularly when the flywheel reaches the predetermined rotational speed at which the PTO is maintained in the first stage, the  
20 clutch engages thereby directly transmitting the rotational movement from the PTO to the flywheel so that the flywheel can be accelerated along with the PTO rotational speed.

Preferably the torque-limiter is integrated into  
25 the transmission means. In case of the clutch, the torque-limiting function can be fulfilled by slip of the discs or by disengaging the discs of the clutch so that the input shaft 11 is disengaged from the output shaft 12. In the case of the gearbox, both the shift clutch for direct connection  
30 and shift clutch for reduced speed can slip or be opened to disengage the input shaft 11 from the output shaft 12. Thereby the torque-limiting function can be integrated into the gearbox.

35 The transmission means (gearbox or clutch) are preferably controlled by a controller (not shown) which is

operationally connected to the tractor. This allows the startup procedure to be automated to require a minimum of attention from the operator.

**CLAIMS**

1. An agricultural baler (1) comprising a flywheel (2) that is connected via a cardan coupling to a connector (4) that is provided to be connected to a PTO (3) of a tractor, so that the flywheel (2) can be driven by the PTO (3), the cardan coupling comprising a torque-limiter (7) adapted for at least partially disengaging the flywheel (2) from the PTO (3) when a predetermined torque is exceeded, characterized in that the cardan coupling further comprises transmission means (8) that are switchable between a startup state and a running state, in the startup state the transmission means being configured to only partially transmit rotational movement of the PTO (3) to the flywheel (2) while in the running state the transmission means being configured to fully transmit rotational movement of the PTO (3) to the flywheel (2).

2. The agricultural baler (1) according to claim 1, wherein the transmission means (8) are formed as a gearbox.

3. The agricultural baler (1) of claim 2, wherein the gearbox is a planetary gearbox.

4. The agricultural baler (1) of claim 2 or 3, wherein in the running state, the gearbox transmits the rotation from PTO (3) to flywheel (2) in a 1 to 1 ratio while in the startup state, the gearbox transmits the rotation from PTO (3) to flywheel (2) in a N to 1 ratio, whereby N is larger than 1.

5. The agricultural baler (1) according to claim 1, wherein the transmission means (8) are formed as a clutch.

6. The agricultural baler (1) according to claim 5, wherein the clutch is fluid cooled.

7. The agricultural baler (1) according to claim 5 or 6, wherein the baler is a friction clutch.

8. The agricultural baler (1) according to any one of the claims 5-7, wherein the clutch comprises multiple disks (10).

9. The agricultural baler (1) according to any one of the claims 5-8, wherein in the running state, the clutch is adapted to be fully engaged so that the rotation from PTO (3) to flywheel (2) is fully transmitted, while in the startup state, the clutch is adapted to be engaged while allowing slipping so that the rotation from PTO (3) to flywheel (2) is only partially transmitted.

15

10. The agricultural baler (1) according to any one of the previous claims, wherein the torque-limiter (7) is integrally formed with the transmission means (8).

20

11. The agricultural baler (1) according to any one of the previous claims, wherein the flywheel (2) has a predetermined rotational speed when the baler is in operation, and wherein the transmission means (8) are configured to be in the startup state when the flywheel is rotating from 0 to 30% from the predetermined rotational speed.

25

12. The agricultural baler (1) according to any one of the previous claims, wherein the transmission means (8) is controlled by a controller that is operationally connected to the tractor.

30

13. The agricultural baler (1) according to claim 12, wherein the controller is provided to instruct the transmission means (8) to switch states.

35

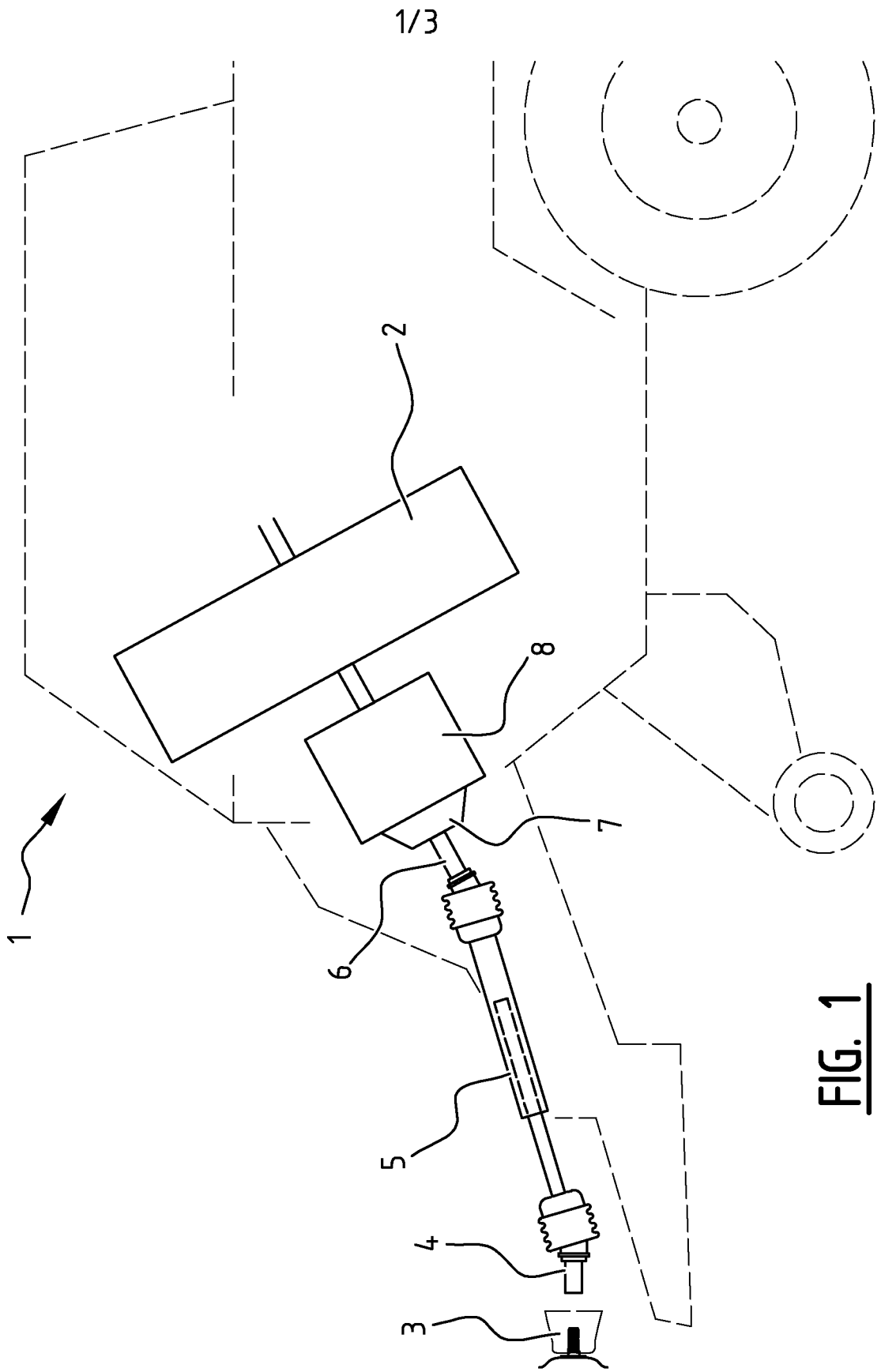

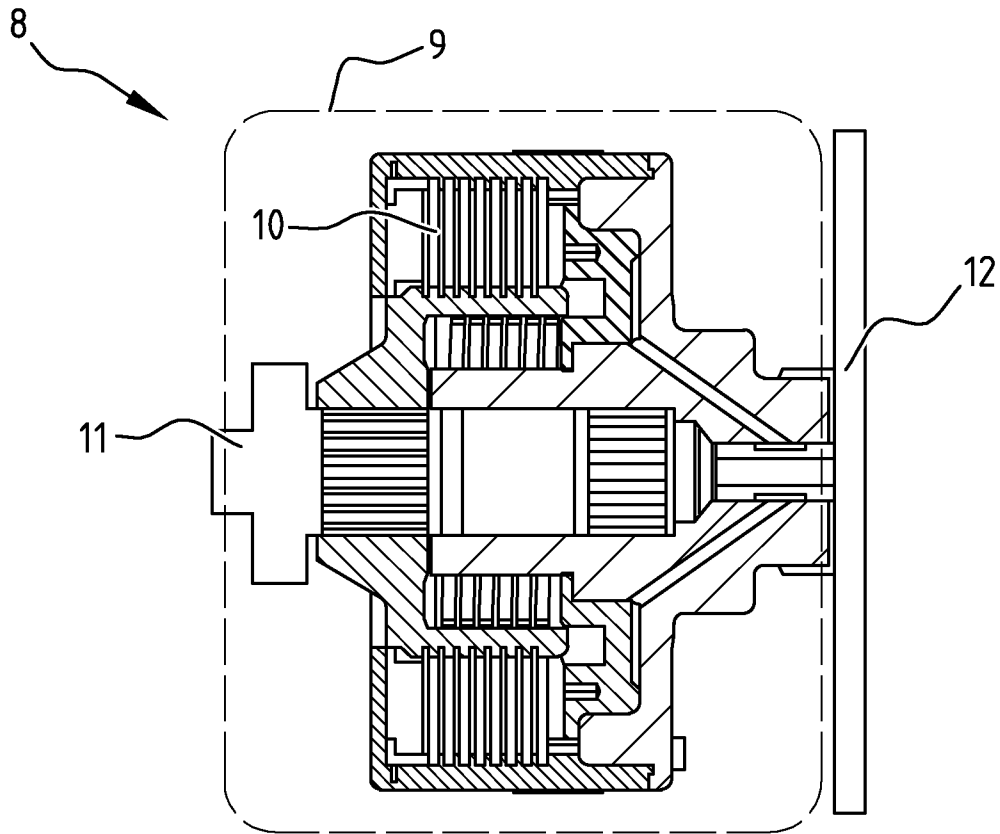

**FIG. 2**

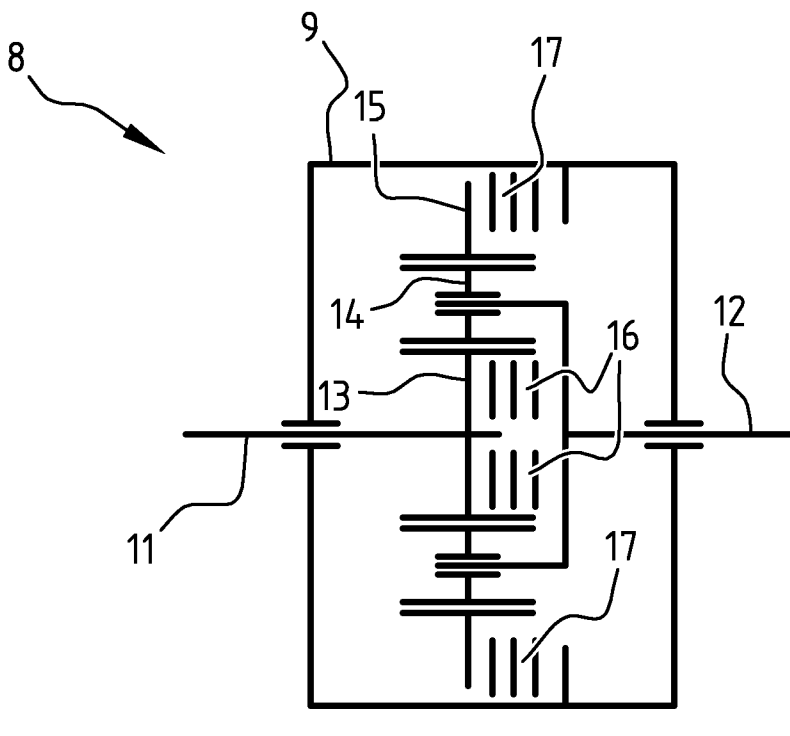

**FIG. 3**

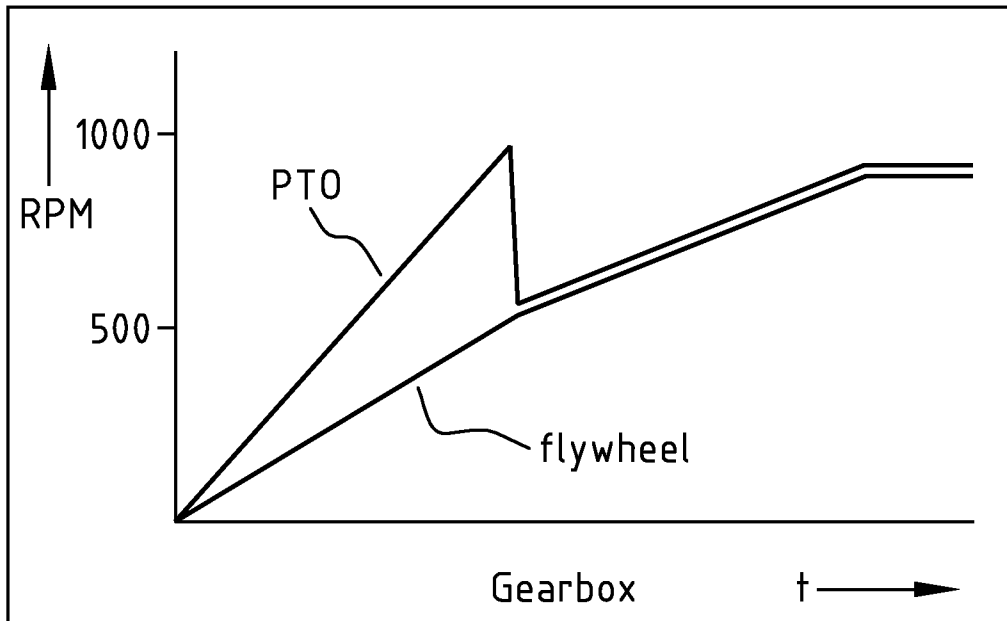

FIG. 4

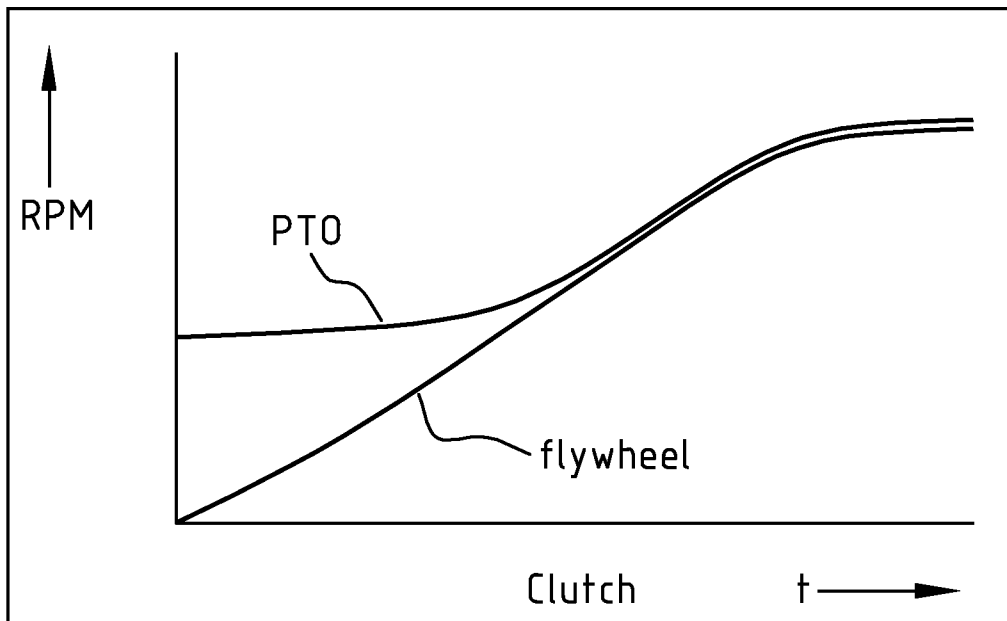

FIG. 5

INTERNATIONAL SEARCH REPORT

International application No  
PCT/EP2014/057607

A. CLASSIFICATION OF SUBJECT MATTER  
INV. A01F15/08 A01B61/02  
ADD.  
According to International Patent Classification (IPC) or to both national classification and IPC

B. FIELDS SEARCHED  
Minimum documentation searched (classification system followed by classification symbols)  
A01F A01B B30B  
Documentation searched other than minimum documentation to the extent that such documents are included in the fields searched

Electronic data base consulted during the international search (name of data base and, where practicable, search terms used)  
EPO-Internal, WPI Data

C. DOCUMENTS CONSIDERED TO BE RELEVANT		
Category*	Citation of document, with indication, where appropriate, of the relevant passages	Relevant to claim No.
X	US 5 894 718 A (HAWLAS MARTIN [DE] ET AL) 20 April 1999 (1999-04-20)	1-4,11
A	page 2, line 37 - line 62 page 4, line 38 - line 52 page 5, line 30 - line 53 figures 1, 2, 5, 6	12,13
Y	----- US 2003/167939 A1 (ROTH DARIN LEDRU [US]) 11 September 2003 (2003-09-11) paragraph [0019]	1,5-9, 11-13
Y	----- US 4 241 654 A (DER LELY CORNELIS VAN [CH]) 30 December 1980 (1980-12-30) column 4, line 32 - line 50	1,5-9, 11-13
A	----- US 2012/310491 A1 (VERMEULEN ANTOON [BE]) 6 December 2012 (2012-12-06) paragraph [0027]	1,2,4, 11-13
	----- -/--	

Further documents are listed in the continuation of Box C.

See patent family annex.

\* Special categories of cited documents :

- "A" document defining the general state of the art which is not considered to be of particular relevance
- "E" earlier application or patent but published on or after the international filing date
- "L" document which may throw doubts on priority claim(s) or which is cited to establish the publication date of another citation or other special reason (as specified)
- "O" document referring to an oral disclosure, use, exhibition or other means
- "P" document published prior to the international filing date but later than the priority date claimed

- "T" later document published after the international filing date or priority date and not in conflict with the application but cited to understand the principle or theory underlying the invention
- "X" document of particular relevance; the claimed invention cannot be considered novel or cannot be considered to involve an inventive step when the document is taken alone
- "Y" document of particular relevance; the claimed invention cannot be considered to involve an inventive step when the document is combined with one or more other such documents, such combination being obvious to a person skilled in the art
- "&" document member of the same patent family

Date of the actual completion of the international search  11 July 2014	Date of mailing of the international search report  22/07/2014
Name and mailing address of the ISA/ European Patent Office, P.B. 5818 Patentlaan 2 NL - 2280 HV Rijswijk Tel. (+31-70) 340-2040, Fax: (+31-70) 340-3016	Authorized officer  Baltanás y Jorge, R

## INTERNATIONAL SEARCH REPORT

International application No  
PCT/EP2014/057607

C(Continuation). DOCUMENTS CONSIDERED TO BE RELEVANT		
Category*	Citation of document, with indication, where appropriate, of the relevant passages	Relevant to claim No.
A	EP 1 974 601 A1 (KRONE BERNARD MASCHF GMBH [DE]) 1 October 2008 (2008-10-01) paragraphs [0017], [0020], [0021] -----	1
A	DE 92 11 256 U1 (MASCHINENFABRIKEN BERNARD KRONE GMBH) 5 November 1992 (1992-11-05) page 13, line 23 - page 15, line 3 figure 3 -----	1,2

# INTERNATIONAL SEARCH REPORT

Information on patent family members

International application No PCT/EP2014/057607
---

Patent document cited in search report	Publication date	Patent family member(s)	Publication date
US 5894718	A	20-04-1999	DE 19628604 A1 22-01-1998 EP 0819374 A1 21-01-1998 US 5894718 A 20-04-1999
-----			
US 2003167939	A1	11-09-2003	NONE
-----			
US 4241654	A	30-12-1980	DE 2819330 A1 16-11-1978 FR 2389798 A1 01-12-1978 GB 1599799 A 07-10-1981 NL 7704935 A 07-11-1978 US 4241654 A 30-12-1980
-----			
US 2012310491	A1	06-12-2012	BE 1019006 A3 06-12-2011 CN 102638966 A 15-08-2012 EP 2501216 A1 26-09-2012 US 2012310491 A1 06-12-2012 WO 2011060995 A1 26-05-2011
-----			
EP 1974601	A1	01-10-2008	AT 502521 T 15-04-2011 DE 102007015649 A1 02-10-2008 EP 1974601 A1 01-10-2008
-----			
DE 9211256	U1	05-11-1992	NONE
-----			