

C. W. WEISS.
ELECTRIC GAS LIGHTER.

No. 314,088.

Patented Mar. 17, 1885.

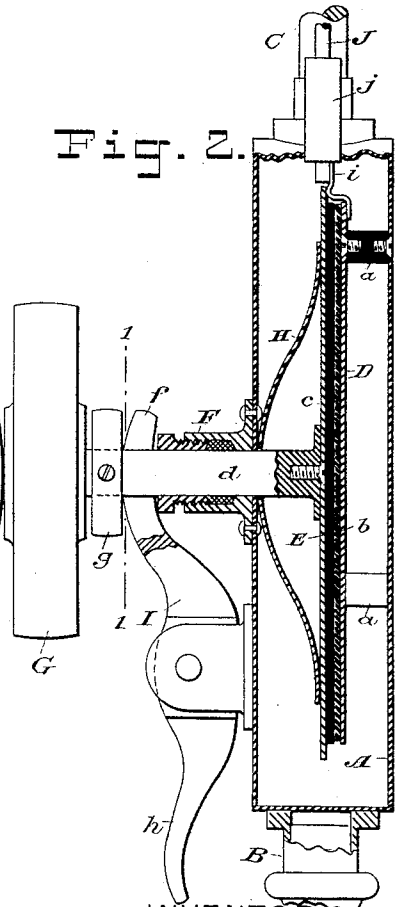
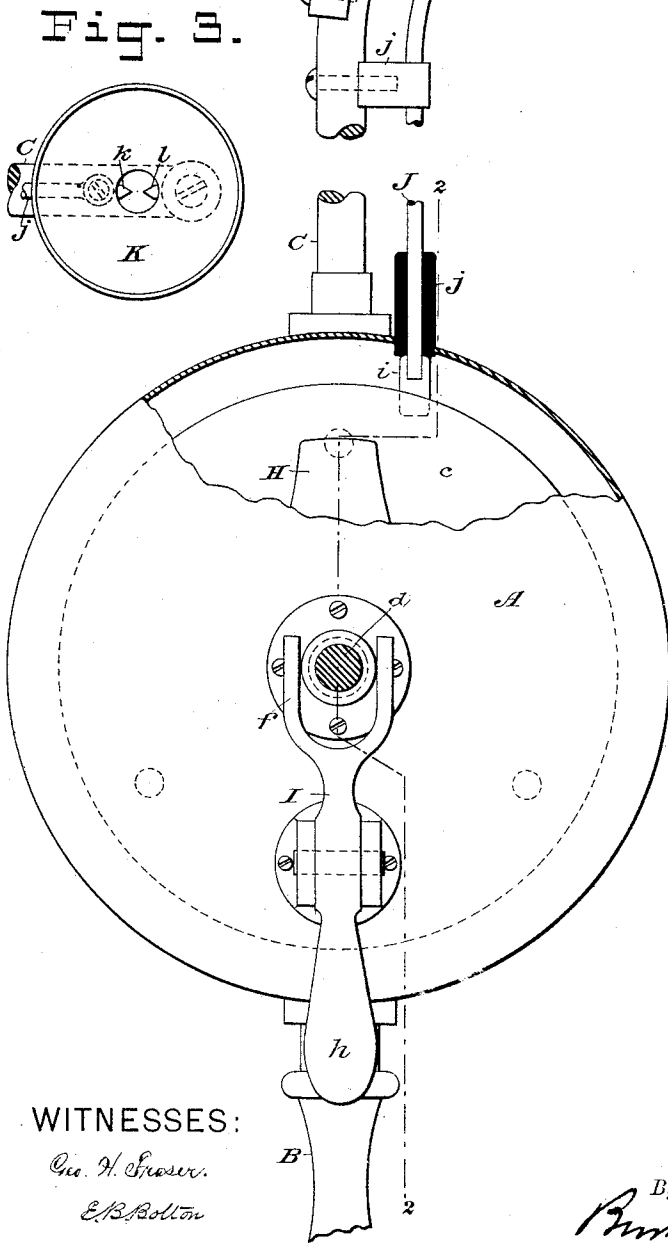
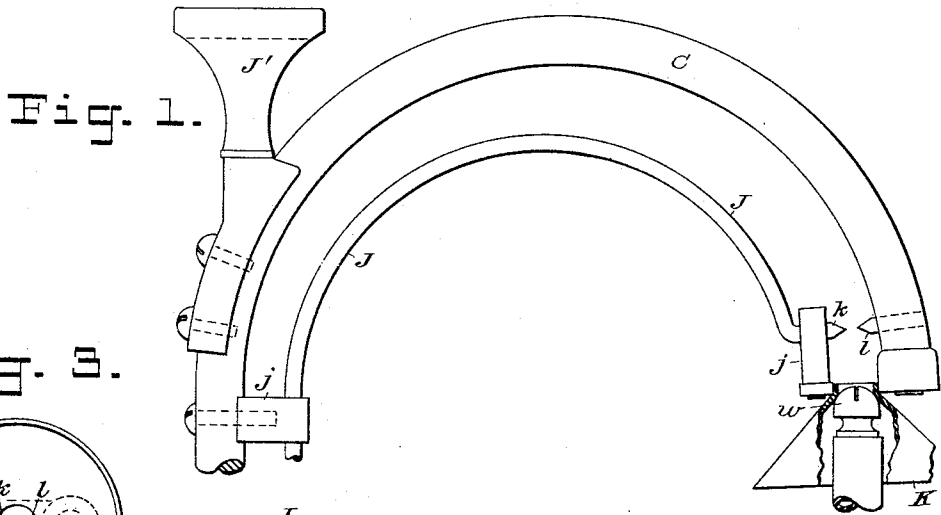

WITNESSES:

Geo. H. Grosver.
E. B. Bolton

INVENTOR:

Charles W. Weiss
By his Attorneys,
Arthur, Isaac Hornum

UNITED STATES PATENT OFFICE.

CHARLES W. WEISS, OF BROOKLYN, NEW YORK, ASSIGNOR, BY DIRECT AND MESNE ASSIGNMENTS, TO THE WEISS MANUFACTURING COMPANY, OF NEW YORK.

ELECTRIC GAS-LIGHTER.

SPECIFICATION forming part of Letters Patent No. 314,088, dated March 17, 1885.

Application filed April 13, 1883. (No model.)

To all whom it may concern:

Be it known that I, CHARLES W. WEISS, a citizen of the United States, and a resident of Brooklyn, Kings county, New York, have invented an Improved Electric Gas-Lighter, of which the following is a specification.

My invention relates to an electrophorus, or device for producing an electric spark, and is designed, primarily, for lighting gas. It is capable, however, of being employed for other purposes where an electric spark is required.

The characteristic features of my invention are these: The generating-plates are inclosed in a hermetic case, whereby they are protected from moisture, yet are capable of being separated, in order to produce the spark. The metallic or positive plate is mounted fixedly, and provided with a stiff or rigid conductor. The spark is produced by the mere separation of the plates and without the necessity of a special contact. The means for moving the resinous or negative plate are simple and convenient.

In the drawings which serve to illustrate my invention, Figure 1 is a side elevation of the apparatus adapted as a portable torch for lighting gas, partly in section on line 1 1 in Fig. 2, and the case partly broken away. Fig. 2 is a section taken substantially on line 2 2 in Fig. 1. Fig. 3 is a detached front view of the funnel-like tip of the torch or lighter. Figs. 4 and 5 are views illustrating the application of my invention to a cigar-lighter, the former being an elevation, partly in section, and the latter a plan.

A represents a hermetically-closed box for the electrophorus. This I usually make of metal, in a circular form; but this is not essential. This case is provided with a suitable handle, B, and a branch, C, preferably curved to enable one to reach the jet when in a globe. It might be straight, however. This branch may be of any length. I have broken it off in Fig. 1 for lack of room.

Within case A is arranged the electrophorus, which I will now describe with reference to Fig. 2.

D is a metal plate mounted on insulating-posts *a a* on the back of the case. The face of this plate D is covered with some soft material, *b*, preferably kid or other soft leather.

E is the resinous plate, which I usually make of hard rubber. This plate is mounted on a metal plate, *c*, which forms a backing. To the center of plate *c* is fixed a cylindrical stem, *d*, which passes out of the case A through a stuffing-box, F, and is provided with a suitable knob or cross-handle, G, whereby the plate E may be turned.

H is a spring of any kind, arranged within the case, and adapted to keep the plate E pressed up to the soft material *b* on plate D; and I is a thumb-lever fulcrumed on the case A, and provided with a forked extremity, *f*, which embraces the stem *d* and takes under a collar, *g*, or other projecting part of same. By means of this lever I the operator is enabled to lift the plate E by pressing on the thumb-piece *h*.

On the insulated metal plate D is a metallic contact-piece, *i*, which is arranged to contact with the plate *c* when the two plates are brought together, as in Fig. 2. This contact-piece is attached to a metallic conductor, J, which may be a wire, and which is led through insulated bearings *j j* along the branch C, where it terminates in a point, *k*, opposite to a point, *l*, on branch C. This branch C is usually a tube, and the conductor J might pass through it.

Having described the construction thus far, I will now describe the operation of the device.

When it is desired to produce a spark, the handle B is grasped by one hand and the resinous plate E given a partial rotation by means of the knob or handle G. This excites the plate through frictional contact with the soft material *b* on plate D. The operator now depresses the lever I with his thumb, and this lifts the resinous plate E from plate D, breaks the contact of *i* with plate *c*, and leaves plate E negatively charged; but when plate E has moved far enough from D, which is positively charged, the latter plate will be discharged from point *k* to point *l*, producing at this interval the desired spark.

To insure the proper excitation of the plate E, I prefer to rotate it by the handle G while it is in contact with *b*, and before lifting it; but this need not be repeated at every operation. The friction caused by the mere lifting

of the plate will ordinarily produce a spark. I have produced many sparks, one after the other, by simply raising and lowering plate E.

In order to steady the torch while igniting the gas from a jet, I usually provide the branch C with a funnel-like tip, K, which takes over the burner-tip *w*, as indicated in Fig. 1, where the tip K is broken away. The curve in C enables me to bring the tip K down over the burner-tip properly.

I make the resinous plate movable, in order that the plate which is charged and discharged may be maintained stationary. This is important, as the conductor J is mounted in fixed insulated bearings, and the plate D is fixedly attached thereto.

The plates E and *c* may be considered as one, the latter being merely a metallic backing, and the soft material *b* may be considered a part of plate D. As will be seen, the point *l* is electrically connected with the plate E through the various parts C, A, F, *d*, and *e*, and to the earth through the body of the operator. The point *k* is electrically connected with the insulated plate D through the conductor J and contact-piece *i*.

I prefer to japan or varnish the conductor J, or to provide it with some other insulating-covering.

J' is a device in the nature of a key for turning on the gas. This possesses no novel features.

Referring now to Figs. 4 and 5, the case A is mounted horizontally on a base, L, which may be of wood. The inner parts, comprising the electrophorus, are the same as shown in Fig. 2. Mounted on the case A is a gas-burner, M, with a tip, *w*, which may be supplied through a flexible tube, *m*. The ordinary gas-cock, *n*, is provided with a lever, *o*, the end of which engages a circumferential groove in the collar *g* on the stem *d*. The points *k* and *l* are arranged over the tip *w*, as clearly shown.

When the thumb-piece *h* on lever I is depressed, the stem *d* is raised; but the engagement of lever *o* with the groove in *g* causes said lever to turn on the gas an instant before the spark is produced, whereby one operation of lever I serves to turn on the gas and ignite it.

If it is desired to leave the gas turned on and ignited, this may be effected by inserting a pin through a hole, *p*, in the fulcrum-bearing of lever I, with which a hole in the lever registers when the parts stand as in Fig. 4. The spring H in case A serves as a retracting-spring to shut off the gas.

The lever I is only a convenience, as is also the spring H. The plate E *c* might be raised and lowered by the knob or handle G.

It is not essential that the contact-piece *i* be employed as the connection between plate D and the conductor J. The latter may be connected with the plate independently of *i*.

I am aware that it is not new to inclose ma-

chines for generating static electricity in hermetic cases; but I am not aware of an electrophorus such as I have herein described having ever been so inclosed.

I am also aware that it has been proposed to connect the movable plate of an electrophorus with the conducting-point by means of a chain or long helical spring. My construction is the reverse of this. I mount the metal plate fixedly in the hermetic case and connect it inside the case with a stiff conductor. By this construction I avoid the use of a yielding chain or spring, which is exposed and liable to be injured or broken. It is also very difficult to obtain perfect conductivity by means of such conductors.

Having thus described my invention, I claim—

1. In an instrument for producing an electric spark, an electrophorus inclosed within a hermetic casing, and the movable plate of the same provided with an operating-stem arranged to pass out from said case through a packed or air-tight passage, the said movable plate being so constructed, substantially as described, that it may be moved toward and from the fixed plate as well as rotated, substantially as and for the purposes set forth.

2. In a portable apparatus for producing an electric spark, an electrophorus inclosed within a hermetic casing, and the movable plate of the same provided with an operating-stem arranged to pass out from said case through a packed or air-tight passage, the said movable plate being so constructed, substantially as described, that it may be moved toward and from the fixed plate as well as rotated, substantially as and for the purposes set forth.

3. In an electric gas lighter, the combination, with the hermetically-sealed case, of the fixed and movable generating-surfaces D E, the conductor J, and mechanism operating from the outside of the case to lift and rotate the plate E, substantially as and for the purpose described.

4. In an electric gas-lighter, the combination, with the hermetically-sealed case, of a fixed metallic plate, an electrical conductor rigidly attached thereto, and means, substantially as described, for electrifying the plate and discharging the same, as set forth.

5. The combination of a hermetically-sealed case of an electrical gas-lighting apparatus with two generating-surfaces inclosed in said case, one of said surfaces constructed and arranged to be separated from the other or turned on its axis at will, substantially as described.

6. In an electric gas-lighter, a thumb-lever having its fulcrum attached to one side of the case, and having its forked end arranged under a collar upon the stem to which the movable generating-surface is attached for the purpose of lifting and lowering said generating-surface, substantially as described.

7. In an electric gas-lighter, the combina-

tion of the fixed and movable generating-surfaces with the thumb-piece and rotating lever, substantially as described.

8. The combination of a hermetically-sealed case of an electrical gas-lighting apparatus with two generating-surfaces inclosed in said case, one of said surfaces being constructed and arranged to be separated from and brought into contact with the other by an axial movement on its stem, substantially as described.

9. The combination of a hermetically-sealed case of an electrical gas-lighting apparatus with two generating-surfaces inclosed in said case, one of said surfaces being constructed and arranged to move from the other and remain parallel to its normal position, substantially as described.

10. In an instrument for producing an electric spark, an electrophorus inclosed within a hermetic casing, and the movable plate of the same provided with an operating-stem arranged to pass out from said casing through an air-tight passage, said plate being provided with a spring to hold it in contact with the fixed plate, and so constructed, substantially as described, that it may be moved toward and from the fixed plate through the medium of its stem and spring, substantially as set forth.

11. An electrophorus wherein the metal plate is fixed in position and insulated and the resinous plate is made movable to and from the metal plate, the whole being inclosed in a hermetic case, substantially as herein set forth.

12. An electrophorus comprising a metal plate to be excited, mounted fixedly in a hermetic case and insulated from the said hermetic case, a conductor of substantially the character described attached to said fixed plate and terminating in a point, a resinous plate mounted movably in said hermetic case, a metallic

contact-piece for connecting the fixed plate electrically with the metal backing of the resinous plate, means, substantially as described, for moving the resinous plate toward and from the fixed plate, and a conductor terminating in a point, connected electrically at all times with the resinous plate through the medium of metallic parts, substantially as and for the purposes set forth.

13. The combination of the hermetic case provided with a stuffing-box, the lever I, the movable plate E c, provided with a stem and a collar, g, or other projecting part, a spring in the case to press the movable plate up to the fixed plate, the insulated fixed plate, the contact-piece, the conductor J, provided with a point, k, and a branch, C, with a point, l, all arranged to operate substantially as set forth.

14. An electrophorus inclosed within a case, and its movable plate provided with a stem which projects out from said case, and means, substantially as described, for raising said movable plate from the outside of the inclosing-case, substantially as described.

15. In an instrument for producing an electric spark, an electrophorus inclosed within a hermetic casing, and the movable plate of the same provided with an operating-stem arranged to pass out from said case through a packed or air-tight passage, the said movable plate being so constructed, substantially as described, that it may be moved toward and from the fixed plate, substantially as and for the purposes set forth.

In witness whereof I have hereunto signed my name in the presence of two subscribing witnesses.

CHARLES W. WEISS.

Witnesses:

HENRY CONNETT,
ARTHUR C. FRASER.