

(19) **DANMARK**

(10) **DK/EP 3582601 T3**



(12) **Oversættelse af
europæisk patentskrift**

Patent- og
Varemærkestyrelsen

-
- (51) Int.Cl.: **A 01 C 1/04 (2006.01)** **A 01 G 9/029 (2018.01)** **A 01 G 24/44 (2018.01)**
- (45) Oversættelsen bekendtgjort den: **2020-09-07**
- (80) Dato for Den Europæiske Patentmyndigheds bekendtgørelse om meddelelse af patentet: **2020-08-05**
- (86) Europæisk ansøgning nr.: **18707102.2**
- (86) Europæisk indleveringsdag: **2018-02-09**
- (87) Den europæiske ansøgnings publiceringsdag: **2019-12-25**
- (86) International ansøgning nr.: **FR2018050318**
- (87) Internationalt publikationsnr.: **WO2018150127**
- (30) Prioritet: **2017-02-17 FR 1751274**
- (84) Designerede stater: **AL AT BE BG CH CY CZ DE DK EE ES FI GB GR HR HU IE IS IT LI LT LU LV MC MK MT NL NO PL PT RO RS SE SI SK SM TR**
- (73) Patenthaver: **Veritable, 19 avenue du Bois Laville, 07000 Lyas, Frankrig**
- (72) Opfinder: **GEHIN, Nicolas, 4 rue Pierre Bourgeois, 69300 Caluire-et-Cuire, Frankrig**
VERNEUIL, Chloé, 4 rue Pierre Bourgeois, 69300 Caluire-et-Cuire, Frankrig
- (74) Fuldmægtig i Danmark: **Plougmann Vingtoft A/S, Strandvejen 70, 2900 Hellerup, Danmark**
- (54) Benævnelse: **ELEMENT TIL DYRKNING AF MINDST EN PLANTE OG FREMGANGSMÅDE TIL FREMSTILLING AF ELEMENTET**
- (56) Fremdragne publikationer:
EP-A1- 3 100 602
WO-A1-2012/001130
DE-U1-202014 101 486
FR-A1- 2 171 020
US-A- 4 586 288

ELEMENT FOR CULTIVATING AT LEAST ONE PLANT
AND METHOD FOR PRODUCING THE ELEMENT

5 The present invention relates to an element intended to be placed in a receptacle for the cultivation of at least one plant. The invention also relates to a system for cultivating at least one plant comprising such an element, and a method for making such an element.

There is a growing demand for indoor potager gardens which enable the cultivation of fruits, vegetables, and aromatic herbs at home, all year round, in a simple manner.

10 Conventionally, such a potager garden is a plant cultivation system which comprises a tank containing water, as well as receptacles placed in the tank and designed to enable the rise of water by capillarity. Each of the receptacles receives an element comprising a body including a substrate, and at least one seed disposed on the body.

15 The elements consist of consumables that the user buys, uses and then replaces at their convenience. It is essential that the seeds are well held on the body during the transport and the storage of the element so that they remain present, of course, but also so that their positioning on the substrate remains unchanged. Indeed, this positioning is generally predetermined to enable satisfactory germination of the seeds. Thus, it is known to provide a device for holding seeds in the receiving zone, in particular in the document
20 FR-A-2171020.

A first known solution consists in providing a lid covering any seeds, the lid having a sticky portion to be affixed on the body of the element, and a non-sticky portion opposite the seeds. The user just has to remove the lid before placing the element in the receptacle. This solution therefore requires an additional operation to be performed by
25 the user and generates waste.

According to a second known solution, any seeds are deposited in a recessed housing formed in the body, and a substrate is deposited over the seeds, by filling the housing. Here again, a sticky lid can be provided, as previously described. Therefore, the same drawbacks as those mentioned above are encountered.

30 A third known solution consists in depositing a drop of a composition containing water and food glue on any seeds. The seeds are thus glued onto the body, which ensures their holding. However, this solution raises a number of problems. In particular, it does not ensure sufficient holding of large-sized seeds, and does not enable satisfactory

management of the moisture content in the vicinity of the seed. Furthermore, while the glue ensures holding of the seeds, in any case small-sized seeds, however, it offers very little protection against external aggression. Moreover, the use of food glue may confer an unnatural appearance likely to discourage the user.

5 The invention aims at providing an element in which the seeds are held in a satisfactory manner, and which solves all or part of the above-mentioned problems.

For this purpose, and according to a first aspect, the invention relates to an element intended to be placed in a receptacle for the cultivation of at least one plant, the element comprising:

10 - a substantially solid body including a substrate capable of allowing said plant to develop;

- at least one seed of said plant disposed on the body in at least one seed receiving area;

- a layer for holding the seeds in said receiving area;

15 characterized in that said holding layer comprises a dried mineral powder forming a deposition configured to securely fix the seed on the body.

The term "substantially solid" means that the element has a defined shape, and that when it is manipulated during its normal use (transportation, installation in the cultivation system), it keeps this shape. This does not exclude a local deformation of the element – for example the creation of a notch by a user's fingernail. Of course, substantial deformation of the element is still possible under efforts greater than those exerted for the intended use of the element.

Moreover, it is specified that the fact that the seed is disposed on the body means that the seed is not pressed into the body itself, but deposited on a surface of the body of the element. This does not exclude the seed being placed in a cavity of the body which is open to the outside of the body, the seed then remaining visible and accessible from outside of the body.

The invention provides that the holding layer comprises a dried mineral powder, i.e. a mineral powder which, initially wet or scattered in an aqueous solution, has dried. In other words, water has been removed, for example by simple air drying and/or by water absorption in the body, typically in the substrate. Thus, on the ready-to-use element, the holding layer is dry, i.e. substantially not impregnated with liquid.

The presence of a holding layer comprising a dried mineral powder has many advantages.

In addition to the simplicity of manufacture, this solution ensures a high reliability of holding of the seeds in the body, whether these are small or large seeds, as well as
5 significant resistance to shocks and vibrations.

The effectiveness of the solution according to the invention appears at the time of transportation, since the dried mineral powder makes it possible to secure the seed on the body, but also at the time of storage and germination. Indeed, the use of a mineral powder enables faster drying than with food glue, which results in reducing the exposure
10 time of the seed to moisture. This results in a better germination rate after conservation since the seed has not remained for any length of time in a moist environment, which could have had the effect of triggering the germination process and compromising the quality of the seed later on. Moreover, at the time of use of the element, the mineral powder provides essential nutrients for the development of the plant.

Another significant advantage of the invention is to provide an element having a
15 natural appearance, which is generally an important factor for the user of such cultivation systems.

According to a possible embodiment, the holding layer covers and encompasses any seeds in the receiving area. The fact of coating the seeds – as opposed to a simple film
20 deposition as is the case with food glue – makes it possible to protect the seeds from external aggressions, but also to provide greater moisture content around the seed at the time of use of the element.

It can be provided that the receiving area comprises a recessed housing formed in the body and upwardly open, in the use position of the element, the seeds being disposed
25 at the bottom of the housing. In this case, the holding layer can at least partially cover the inner surface of the housing, and not only the seeds. Thus, even better protection of the seed is obtained.

The mineral powder can be a natural mineral powder. For example, it can contain silicates.

According to a possible embodiment, the mineral powder is selected from the
30 group including: clay, talc, pumice stone.

The mineral powder can have a grain-size between 5 and 200 μm , preferably between 20 and 100 μm , more preferably between 30 and 60 μm , for example in the range of 45 μm .

Moreover, the holding layer can comprise at least one compound selected from: a
5 fungicide, a germination promoter agent.

According to a second aspect, the invention relates to a system for cultivating at least one plant, comprising:

- a vat including a bottom, a peripheral wall and an upper opening, said vat being intended to contain water;
- 10 - a tray disposed at the level of the upper opening of the vat, including at least one aperture;
- at least one mast supporting at least one light source;
- at least one element such as described above;
- at least one receptacle comprising a bottom and a peripheral wall, the receptacle
15 receiving said element and being placed in the vat and received in an aperture of the tray.

According to a third aspect, the invention relates to a method for making an element intended to be placed in a receptacle for the cultivation of at least one plant, the element comprising a substantially solid body including a substrate capable of allowing said plant to develop, and at least one seed of said plant disposed on the body in a seed
20 receiving area, the method comprising the deposition of a holding composition on the seeds previously disposed on the body, in order to hold the seeds in said receiving area. According to the invention, the method comprises the deposition of a holding composition which includes a mineral powder suspended in water.

Concretely, the substrate contained in the body or forming the body quickly
25 absorbs the liquid, leaving a clay deposition (and possible additives) on the surface of the body, this deposition covering and encompassing the seeds. The drying of the substrate then makes it possible to dehydrate the clay layer and securely hold the seeds at the required location. In practice, it is possible to proceed with natural drying, by keeping the element in a standard indoor environment (conventional humidity and temperature) for
30 a drying phase of about twelve hours, before the final conditioning.

In addition to the advantages obtained on the ready-to-use element, as previously described, the method according to the invention also has advantages, in particular great simplicity of implementation. Moreover, the method according to the invention makes it

possible to adapt the composition easily according to the seeds, in particular the amount of mineral powder according to the size of the seeds, and/or possible additives according to the required properties (germination time, protection against diseases, fungi, etc.).

5 The mineral powder can be a natural mineral powder, that can for example contain silicates. The mineral powder can be selected from the group comprising: clay, talc, pumice stone.

According to a possible embodiment, the holding composition comprises from 15 to 25% by weight, for example in the range of 20% by weight, of mineral powder. This mineral powder can have a grain-size between 5 and 200 μm , preferably between 20 and 100 μm , more preferably between 30 and 60 μm , for example in the range of 45 μm . In 10 particular it can consist of a clay powder having a grain-size close to 45 μm .

The method can include mixing the holding composition prior to its deposition over the seeds. As such mixing aims to prevent the mineral powder from depositing or amalgamating, and to homogenize the holding composition, it is preferably carried out 15 immediately before the deposition of the holding composition over the seeds.

The deposition of the holding composition can be carried out by means of a pump system. Alternatively, it can be carried out manually, for example with a pipette.

Moreover, the holding composition can comprise at least one compound selected from: a fungicide, a germination promoter agent.

20 When the receiving area comprises a recessed housing formed in the body and upwardly open, in the use position of the element, the seeds being disposed at the bottom of the housing, the method can comprise the deposition of a holding composition in sufficient amount to substantially fill the housing.

Now described, as non-limiting example, is a possible embodiment of the invention, 25 with reference to the appended figures:

FIG. 1 is an exploded perspective view of a system for cultivating at least one plant according to the invention;

FIG. 2 is a perspective view of an element according to the invention, ready to be placed in a receptacle of the system;

30 FIG. 3 is a schematic view of an element illustrating the deposition of seeds and a composition for holding the seeds on the element;

FIGS. 4a to 4d schematically illustrate steps of the method for depositing a holding composition on an element;

FIG. 5 is a schematic representation of a possible embodiment of the method according to the invention.

FIG. 1 represents a system 100 for cultivating at least one plant, which is particularly suited to enable cultivation inside a building.

5 The system 100 comprises a vat 1 which includes a bottom 2, generally planar, a peripheral wall 3 and an upper opening 4. The vat 1 is for example substantially parallelepipedal. A sealed receiving space, intended to contain water or another appropriate liquid, is thus defined inside the vat 1, to enable the cultivation of the plants.

10 The vertical direction Z, orthogonal to the bottom 2 when the vat 1 is placed on a support such as a table or a worktop, is defined. The horizontal direction X, parallel to the long sides of the vat 1, and the horizontal direction Y, parallel to the short sides of the vat 1, are also defined. In the following description, the different parts or components will be described in the position they occupy in operation.

A support 5 projects from the bottom 2 of the vat 1, in the Z direction and upwards.

15 One or more masts 6 (two masts in the example shown) are fitted onto or in the support 5. Each mast 6 carries a plurality of light sources 7, for example light-emitting diodes (LEDs), providing the luminous energy necessary for the growth of the plants.

The system 100 further comprises a tray 10 disposed at the level of the upper opening 4 of the vat. The tray 10 can for example be removably fastened to the upper
20 edge 9 of the peripheral wall 3 of the vat 1.

The tray 10 comprises at least one aperture 11 intended to receive a receptacle 20 containing the plants, the aperture 11 preferably having a shape complementary to that of the receptacle 20. In the embodiment shown as example, the tray 10 comprises four apertures 11. Furthermore, the apertures 11 are substantially rectangular, with the long
25 side oriented parallel to Y, this being not limiting. The tray 10 further comprises holes 12 for the passage of the masts 6, and a hole 13 enabling the user to pour water at the bottom of the vat 1 without having to remove the tray 10.

A receptacle 20 is intended to be placed in the vat 1, in each of the apertures 11 of the tray 10. The receptacle 20 can be made of plastic material, for example by moulding.
30 The receptacle 20 comprises a bottom 22 and a peripheral wall 23, and has an upper opening 24. Here it is substantially parallelepipedal, this not being limiting.

The receptacle 20 can be provided with legs 27 extending down from the bottom 22, to enable support on the bottom 2 of the tank 1 and holding away from the bottom 2

of the vat 1. It can be provided that, in mounted position, the receptacle 20 is substantially flush with the tray 10.

Moreover, the receptacle 20 comprises a chimney 31 which extends substantially vertically down from the bottom 22, over a height smaller than or equal to that of the legs 27, and which opens into the bottom 22. In the chimney 31 is disposed a capillary liquid transport member, such as a wick. For this member to be in contact, in its lower part, with the water present in the vat 1, it is possible for the member to extend beyond the lower end of the chimney 31, and/or that the chimney 31 includes an orifice 34, at its lower part, through which water can penetrate so as to reach the member.

Moreover, the system 100 comprises at least one element 50 which is intended to be placed in a receptacle 20, as schematically illustrated in FIG. 2. The element 50, which constitutes a ready-to-use refill, has a substantially solid body 52, whose dimensions enable it to be inserted into a receptacle 20. The element 50 can thus generally have a parallelepiped shape. As example, its dimensions can be the following: $dx = 140$ mm, $dy = 40$ mm, $dz = 80$ mm.

The body 52 includes a substrate capable of allowing the plant to develop. The substrate can for example include one or more cellulosic materials, in the form of fibres and/or powder, such as coconut fibres, bamboo fibres, coconut powder. The body 52 can also comprise a fertilizer.

The element 50 further comprises at least one seed 51, and in practice several seeds 51 (see FIG. 3). The seeds 51 are disposed on the body 52 in at least one seed receiving area. For example, as illustrated in FIGS. 2 and 3, the receiving area comprises a recessed housing 53 formed in the body 52 and upwardly open, in the use position of the element 50. The seeds 51 are then disposed at the bottom of the housing 53, as shown in particular in FIG. 4a. In the embodiment shown as example, the body 52 of the element 50 has five housings 53 aligned in the Y direction, and regularly spaced, this not being limiting.

In order to ensure holding of the seeds 51 on the body 52 of the element 50, in the position which has been predetermined to ensure efficient germination and growth, it is planned to produce a seed holding layer in the seed receiving area 51.

Next, the description will be given for the case where the seed receiving area is formed in the housing 53.

As illustrated in FIGS. 3 and 4a, one or more seeds 51 are placed at the bottom of each housing 53. Then, a holding composition 60 is disposed on the seeds 51.

According to the invention, the holding composition 60 comprises a mineral powder suspended in water.

5 For example, this mineral powder can consist of clay, preferably relatively fine, for example having a grain-size between 30 and 60 μm , in the range of 45 μm . The holding composition 60 can comprise from 15 to 25% by weight of clay, for example in the range of 20% by weight. Other mineral powders can be used, like for example talc or pumice stone. These choices are advantageous in that they provide natural solutions, unlike food
10 glue.

The holding composition 60 can also comprise a fungicide 20 and/or a germination promoter agent.

The holding composition 60 is deposited in an appropriate amount to allow for a satisfactory holding of the seeds 51. Concretely, one or more drops 61 of the holding
15 composition 60 can be deposited, for example to substantially fill the housing 53, as shown in FIG. 4b.

The deposition can be carried out manually. Alternatively, it can be carried out using a mechanical, electrical and/or hydraulic system, by means of a pump 40 and tubes 41, as illustrated in FIG. 5.

20 In order to ensure proper homogeneity of the holding composition 60 which will be deposited over the seeds 51, this holding composition 60 is preferably continuously mixed before its deposition, thereby keeping the clay powder in suspension. Obtaining a homogeneous liquid is particularly easy as the used clay is in the form of a very fine powder. In FIG. 5, as example, the holding composition 60 intended to be sucked by the
25 pump 40 is placed in a receptacle 42 on a magnetic stirring system 43. Other solutions can nevertheless be envisaged (mechanical stirring, etc.).

The water contained in the holding composition 60 deposited in the housing 53 will then be absorbed by the body 52, typically by the substrate, and may also be partially evaporated, as shown in FIG. 4c, then in FIG. 4d.

30 Tests have shown that the period during which the mineral powder remains very wet is about 1 minute (this corresponds to the time of absorption of water by the substrate). This time is relatively short, compared with the solution consisting in depositing food glue where the wet period can be close to 10 minutes. The method

according to the invention is thus more advantageous because as the seed is less exposed to moisture before use of the element 50, it is not altered and has an enhanced germination capacity after conservation. Then comes the evaporation drying phase.

5 The dried mineral powder – here the clay – is then deposited on the surface of the body 52 to form a holding layer 62, shown in FIG. 4d. The holding layer 62, which thus comprises the dried mineral powder, covers and encompasses the seeds 51 in the receiving area, here formed by the housing 53. The holding layer 62 can also at least partially cover the inner surface 54 of the housing 53.

10 As shown by comparing FIGS. 4b and 4d, the holding layer 62 has a much smaller volume than the drops of the holding composition that have been deposited in the housing 53. In particular, the holding layer 62, which is then dry, does not fill the entire housing 53. As example, the thickness of the holding layer 62 can be between 0.2 and 2 mm according to the clay concentration in the holding composition 60, and the amount of deposited holding composition 60.

15 The element 50 thus made, containing the seeds 51 securely fixed on the body 50 thanks to the holding layer 62, can be transported and stored without risk for the seeds 51, until use by the consumer.

20 Concretely, the user has only to place an element 50 in a receptacle 20. By capillarity, the substrate will be rehydrated, and bring moisture to the holding layer 62 and to the seeds 51. Compared with the solutions of the prior art, and in particular to the use of food glue, the use of a mineral powder is advantageous because it makes it possible, in operation, to form a wetter environment for the seed 51, which is helpful to its development.

25 Another significant advantage of the invention lies in the fact that the holding composition 60 can be easily adapted to the different types of seeds 51, in order to ensure appropriate holding on the body 50 and satisfactory protection.

30 Thus, on the one hand, the holding composition 60 can be adapted to the size of the seeds 51. Indeed, there are small-sized seeds, generally spherical or having a substantially rounded shape, which can be easily fixed. But there are also larger seeds, such as tomato and pepper seeds (quite-flat disc shaped) or chive seeds (striated half-moon shaped), as well as coated seeds, which are heavy and generally spherical with a diameter ranging from 2 to 5 mm. These larger seeds are very difficult to hold on the body with the solutions of the prior art. The invention makes it possible, on the contrary, to

ensure effective holding of these seeds, thanks to the use of dried mineral powder. In addition, by increasing the concentration of mineral powder in the holding composition (up to about 30%, for example), a thicker dried powder deposition is obtained, and this thicker holding layer enables better holding of the large seeds.

5 On the other hand, the holding composition 60 can be adapted to the nature of the seeds, the substrate and/or the environmental conditions, in particular, by the presence of additives selected to improve the germination time, to protect against diseases or fungi, etc.

10 Thus, the invention brings a decisive improvement to the prior art, by providing an element which can be transported, stored and used without risk of loss or alteration of the seeds.

 Of course, the invention is not limited to the embodiment described above as example, but it comprises all the technical equivalents and variants of the described means as well as their combinations, as described in the appended claims.

Patentkrav

- 1.** Element beregnet til at blive placeret i en beholder (20) til dyrkningen af mindst en plante, hvilket element (50) omfatter:
- et i alt væsentligt fast legeme (52) som omfatter et substrat, som er egnet til at lade planten udvikle sig;
 - mindst et frø (51) fra planten anbragt på legemet (52) i mindst et frømodtagelsesområde (53);
 - et fastholdelseslag (62) til at holde frøet eller frøene (51) i modtagelsesområdet (53);
- 10 **kendetegnet ved, at** fastholdelseslaget (62) omfatter et tørret mineralpulver, som danner en aflejring konfigureret til fastholde frøet på legemet.
- 2.** Element ifølge krav 1, **kendetegnet ved, at** fastholdelseslaget (62) dækker og omslutter frøet eller frøene (51) i modtagelsesområdet (53).
- 15
- 3.** Element ifølge krav 1 eller 2, **kendetegnet ved, at** modtagelsesområdet (53) omfatter en hul fordybning dannet i legemet (52) og åben foroven, i elementets (50) anvendelsesposition, hvor frøet eller frøene (51) er anbragt i bunden af fordybningen (53).
- 20
- 4.** Element ifølge krav 3, **kendetegnet ved, at** fastholdelseslaget (62) mindst delvist dækker fordybningens (53) indvendige overflade.
- 5.** Element ifølge et af kravene 1 til 4, **kendetegnet ved, at** mineralpulveret er et naturligt mineralpulver, som for eksempel kan indeholde silikater.
- 25
- 6.** Element ifølge et af kravene 1 til 5, **kendetegnet ved, at** mineralpulveret er valgt fra gruppen omfattende: ler, talk, pimpsten.
- 7.** Element ifølge et af kravene 1 til 5, **kendetegnet ved, at** mineralpulveret har en kornstørrelse omfattet mellem 5 og 200 μm , fortrinsvis mellem 20 og 100 μm , mere fortrinsvis mellem 30 og 60 μm .
- 30
- 8.** System til dyrkning af mindst en plante, omfattende:

- et kar (1) som omfatter en bund (2), en periferisk væg (3) og en øvre åbning (4), hvilket kar (4) er beregnet til at indeholde vand;
- en bakke (10) anbragt ved niveauet af den øvre åbning (4) af karret (1), som omfatter mindst et vindue (11);
- 5 - mindst en stang (6), som bærer mindst en lyskilde (7);
- mindst et element (50) ifølge et af kravene 1 til 7;
- mindst en beholder (20), som omfatter en bund (22) og en periferisk væg (23), hvilken beholder (20) modtager elementet (50) og er anbragt i karret (1) og modtaget i et vindue (11) i bakken (10).

10

9. Fremgangsmåde til fremstilling af et element (50) beregnet til at blive placeret i en beholder (20) til dyrkningen af mindst en plante, hvilket element (50) omfatter et i alt væsentligt fast legeme (52), som omfatter et substrat, som er egnet til at lade planten udvikle sig, og mindst et frø (51) af planten anbragt på

15 legemet (52) i et frømodtagelsesområde (53), hvilken fremgangsmåde omfatter aflejringen af en fastholdelsessammensætning (60) på frøet eller frøene (51) tidligere anbragt på legemet (52), for at holde frøet eller frøene (51) i modtagelsesområdet (53), **kendetegnet ved, at** fremgangsmåden omfatter

20 mineralpulver opslæmmet i vand.

10. Fremgangsmåde ifølge krav 9, **kendetegnet ved, at** fastholdelsessammensætningen (60) omfatter fra 15 til 25 vægtprocent, for eksempel omkring 20 vægtprocent, ler, som har en kornstørrelse omfattet mellem

25 30 og 60 μm , for eksempel omkring 45 μm .

11. Fremgangsmåde ifølge krav 9 eller 10, **kendetegnet ved, at** den omfatter omrøring af fastholdelsessammensætningen (60) forud for dens aflejring på frøet eller frøene (51).

30

12. Fremgangsmåde ifølge et af kravene 9 til 11, **kendetegnet ved, at** fastholdelsessammensætningen (60) yderligere omfatter mindst en forbindelse valgt fra: et svampemiddel, et spiringsfremmende middel.

13. Fremgangsmåde ifølge et af kravene 9 til 12, hvor modtagelsesområdet (53) omfatter en hul fordybning dannet i legemet (52) og åben foroven, i elementets (50) anvendelsesposition, hvor frøet eller frøene (51) er anbragt i bunden af fordybningen (53), **kendetegnet ved, at** der anbringes en fastholdelses-
5 sammensætning (60) i en mængde, som er tilstrækkelig til i alt væsentligt at fylde fordybningen (53).

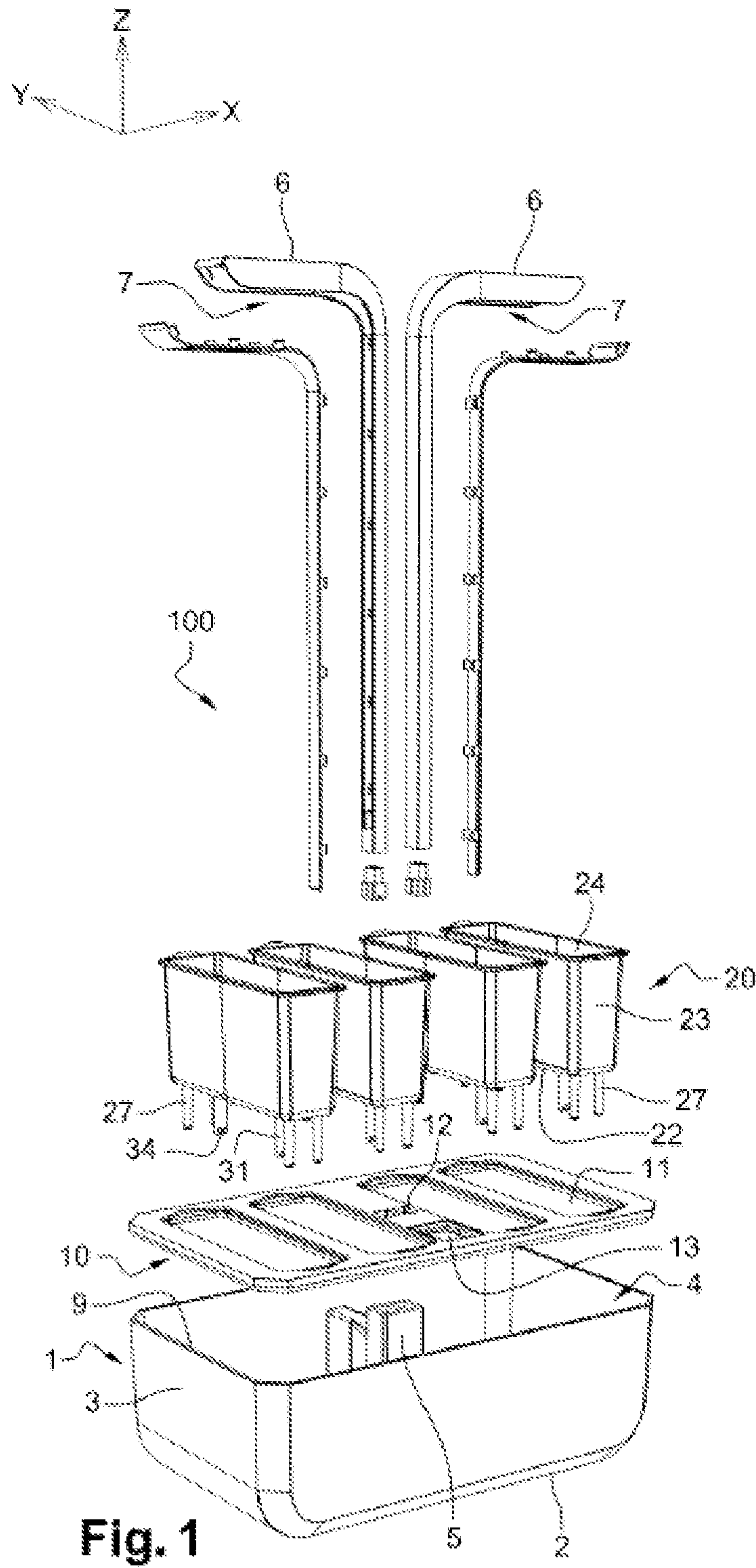

Fig. 1

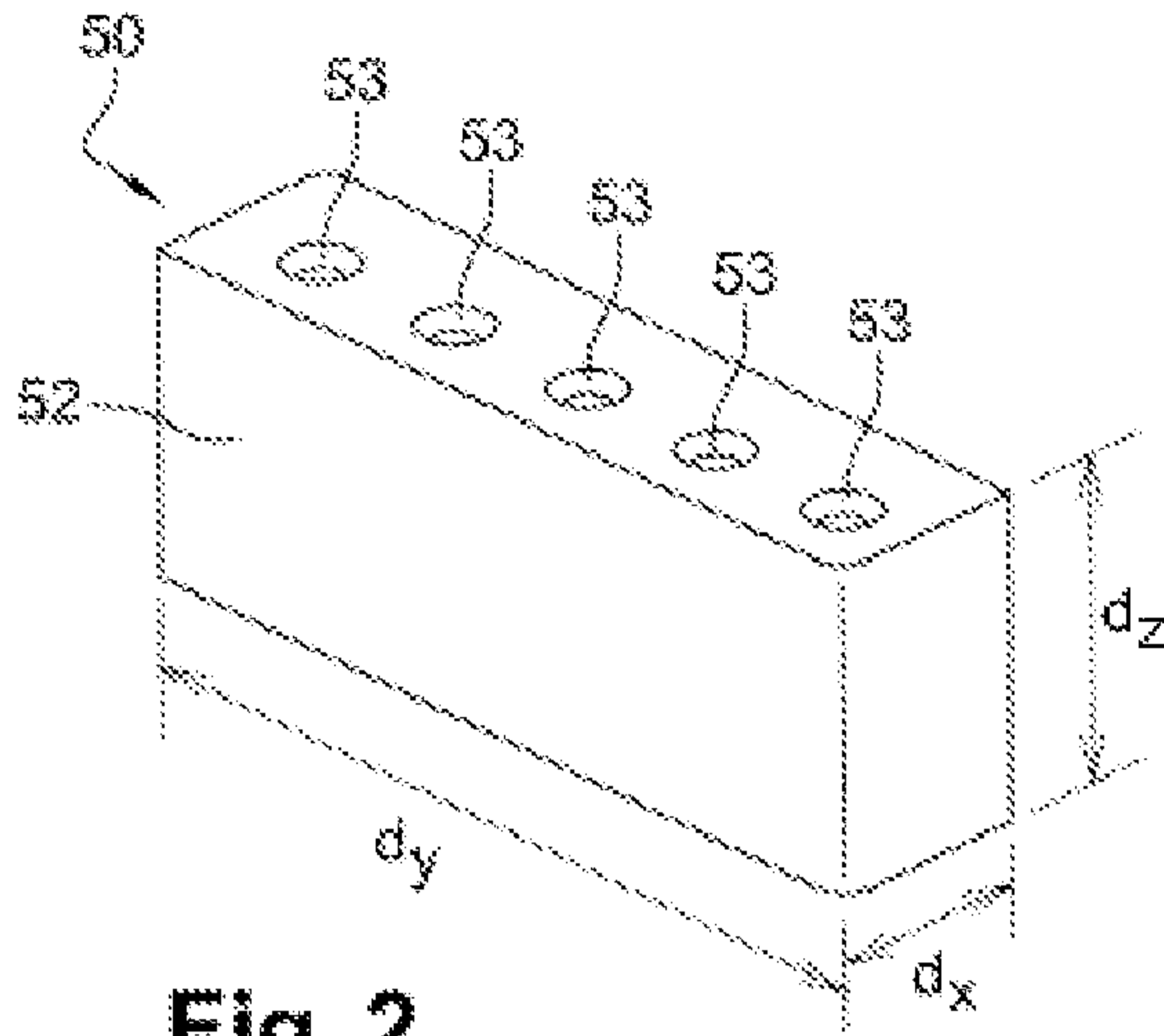

Fig. 2

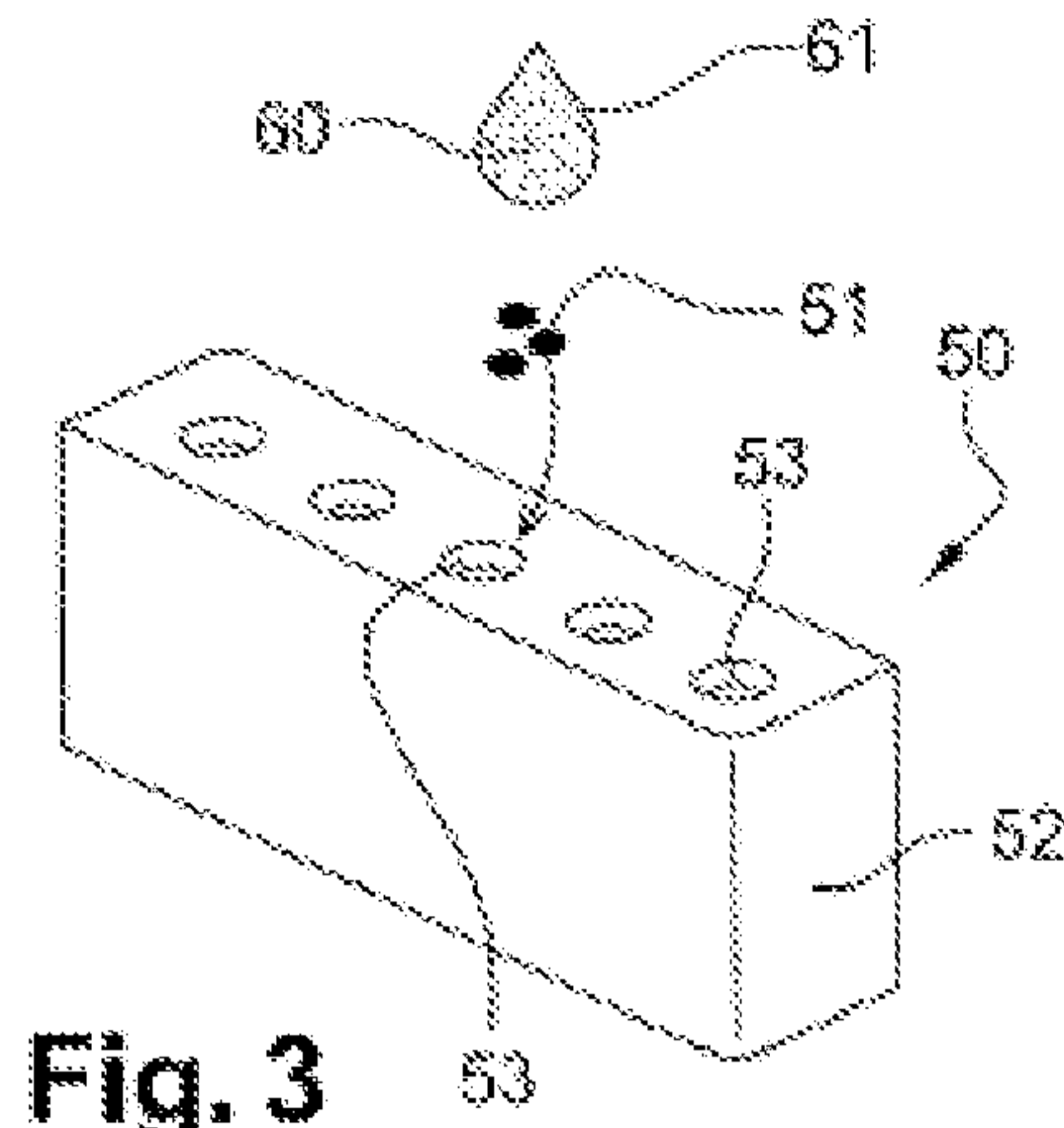

Fig. 3

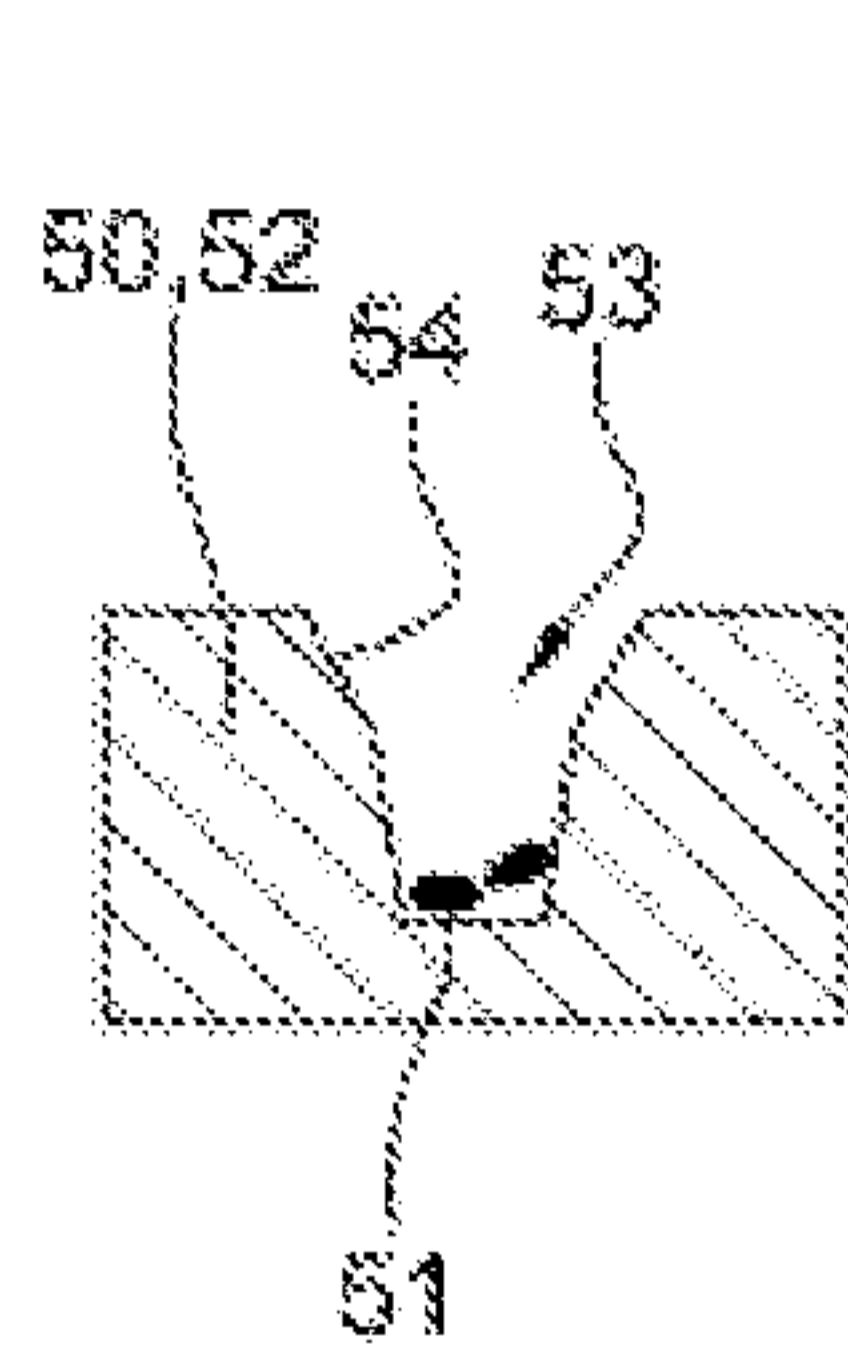

Fig. 4a

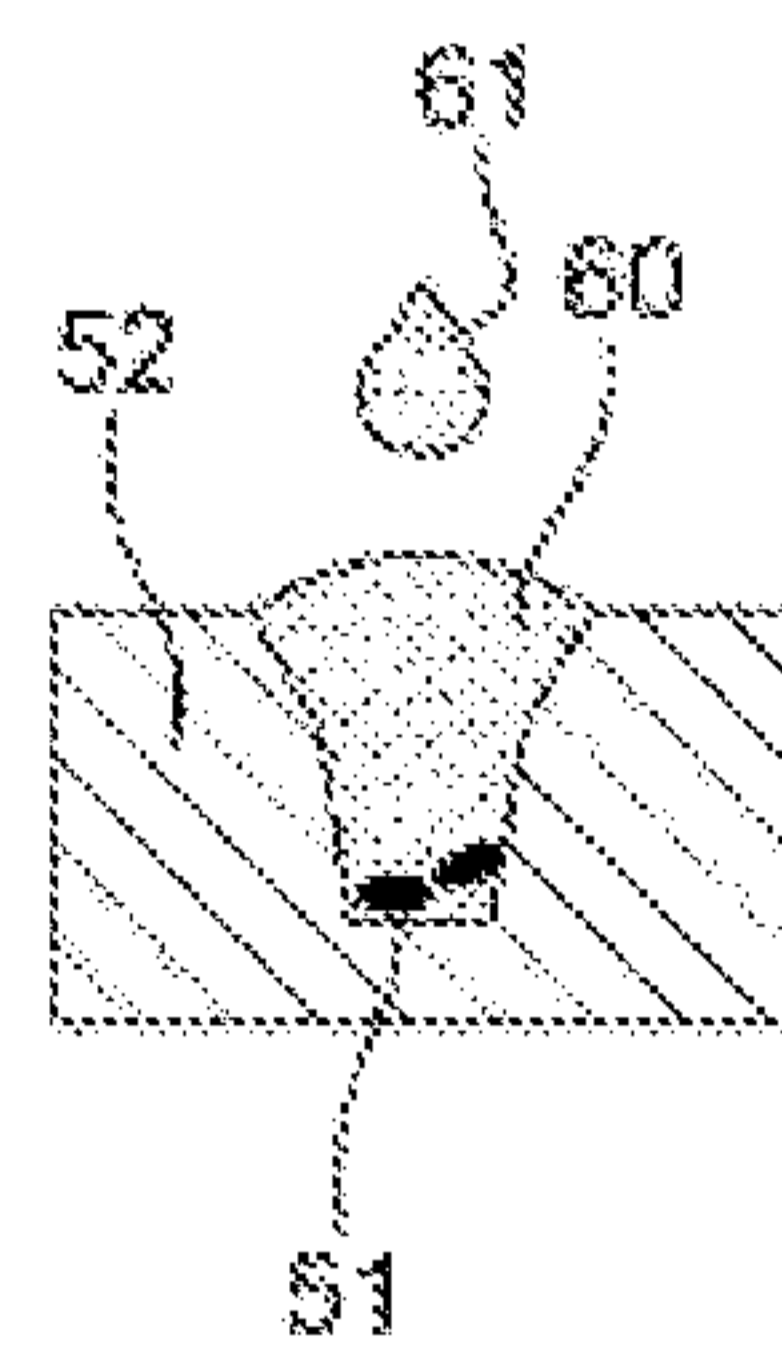

Fig. 4b

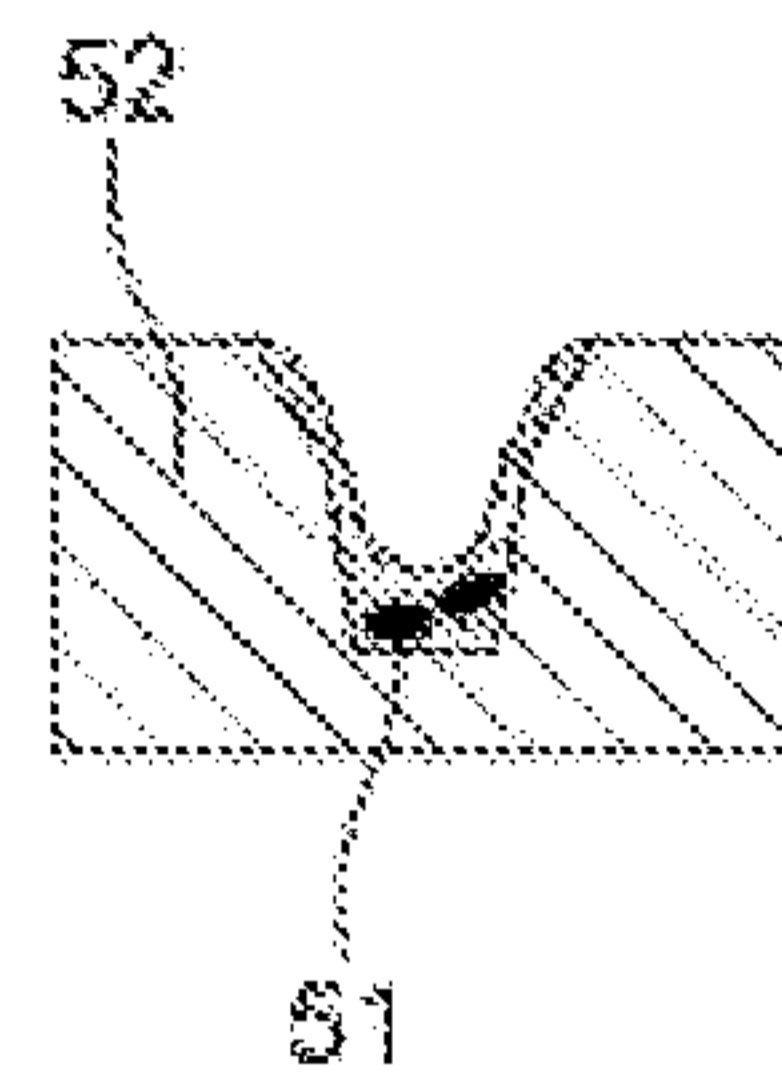

Fig. 4c

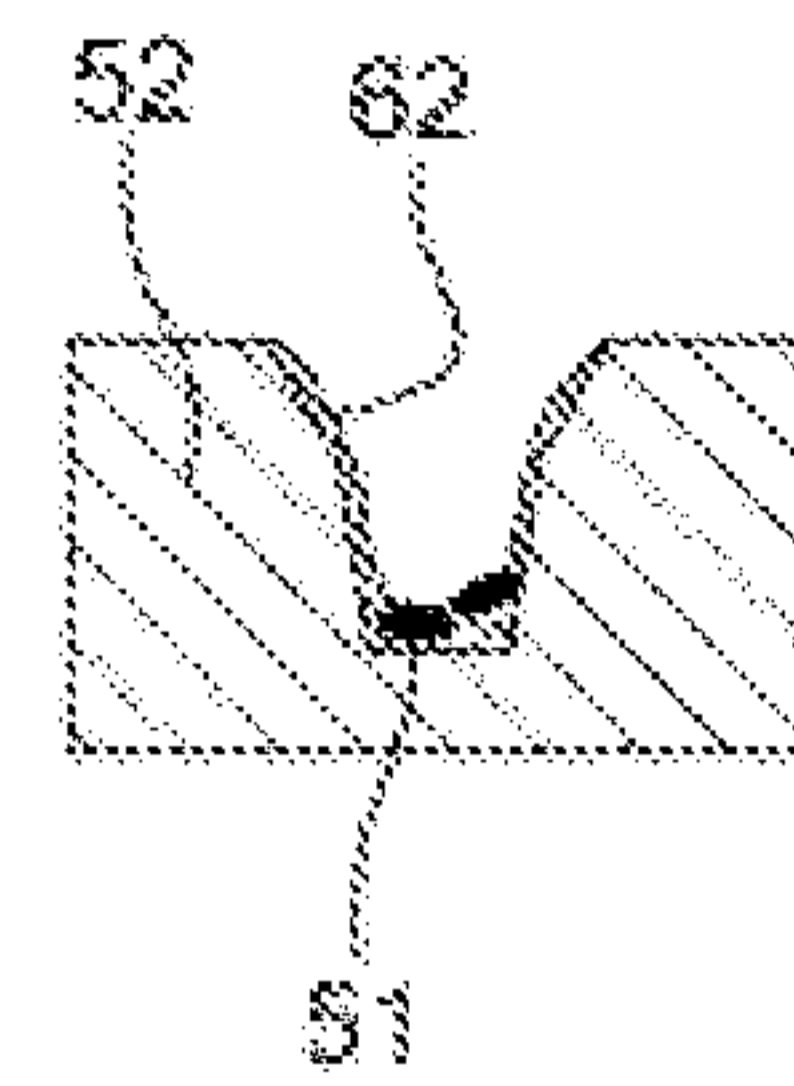

Fig. 4d

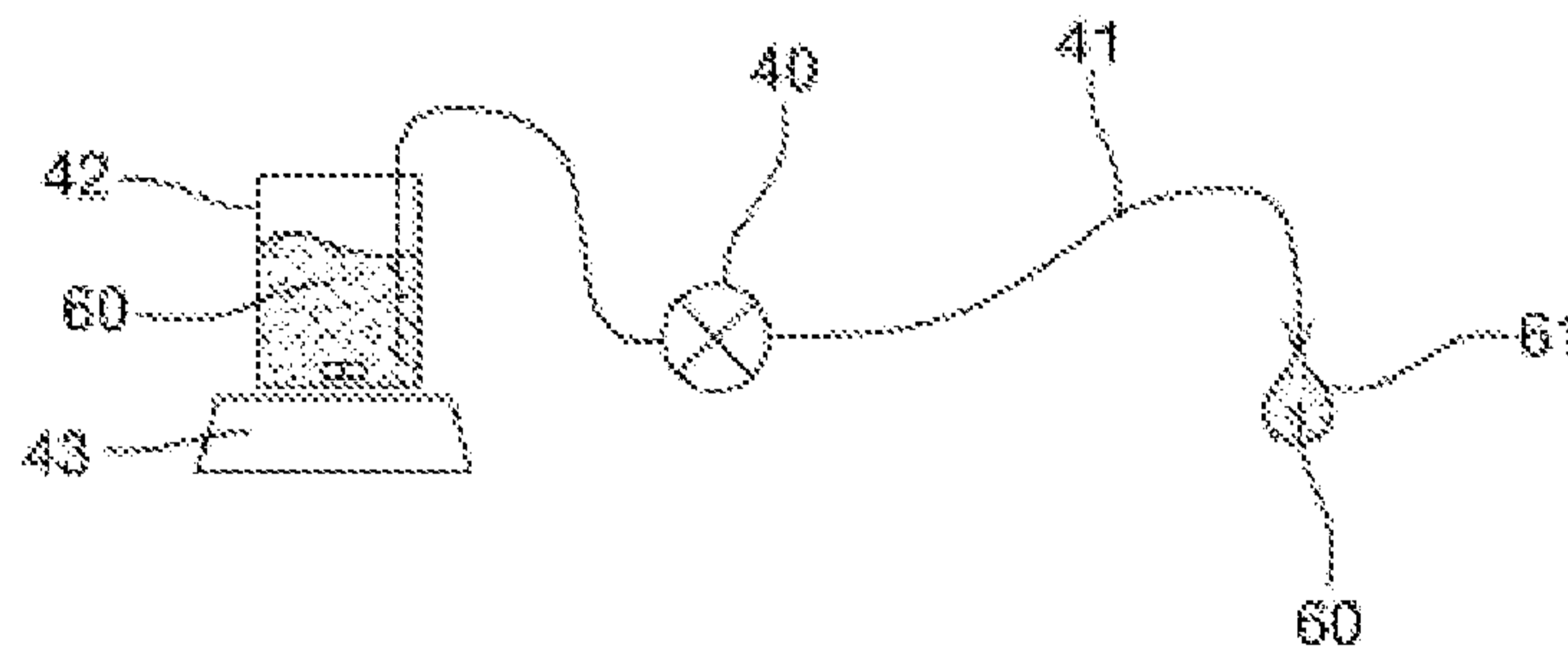

Fig. 5