

E. MEYER.

VIBRATORY APPARATUS FOR EAR TREATMENT.

APPLICATION FILED DEC. 24, 1906.

2 SHEETS—SHEET 1.

Fig. 1.

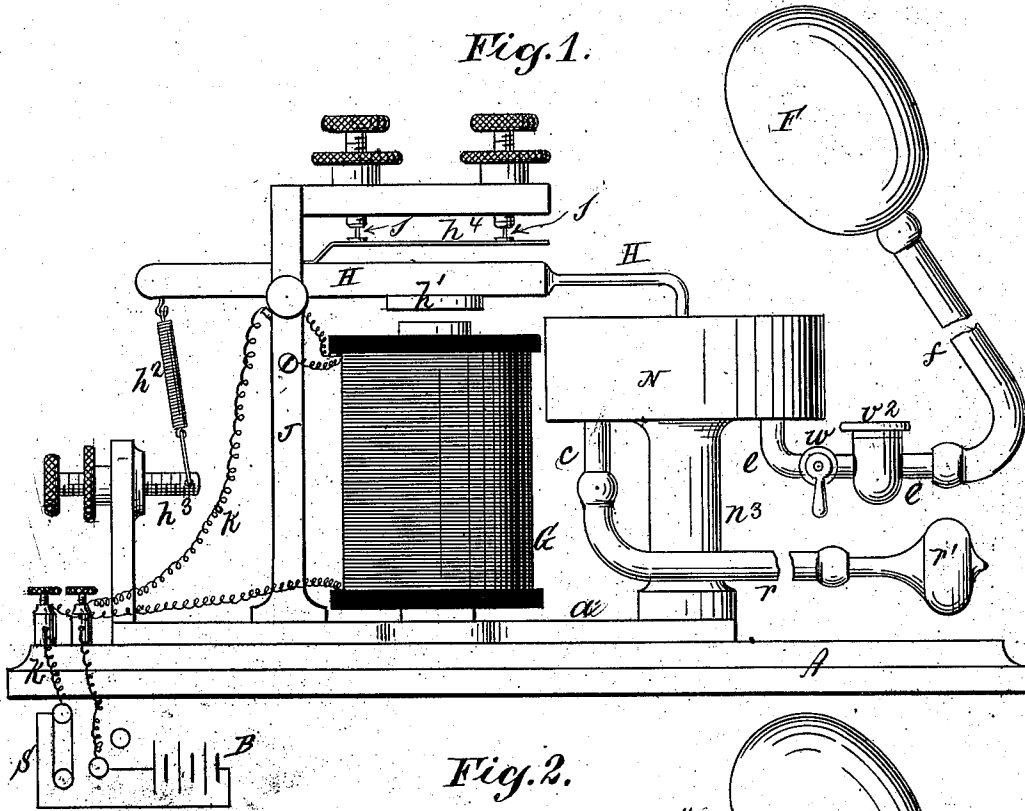
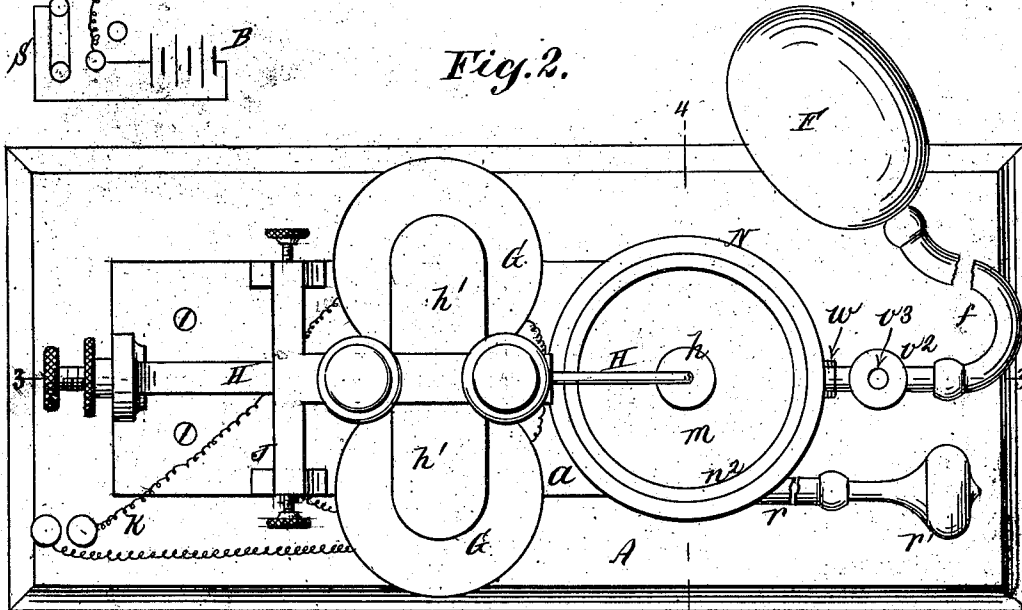

Fig. 2.



Witnesses
 D. W. Gardner
 G. Licks

Inventor:
 Eugene Meyer
 By his Attorney
 Geo. M. Meath

E. MEYER.
VIBRATORY APPARATUS FOR EAR TREATMENT.

APPLICATION FILED DEC. 24, 1906.

2 SHEETS—SHEET 2.

Fig. 3.

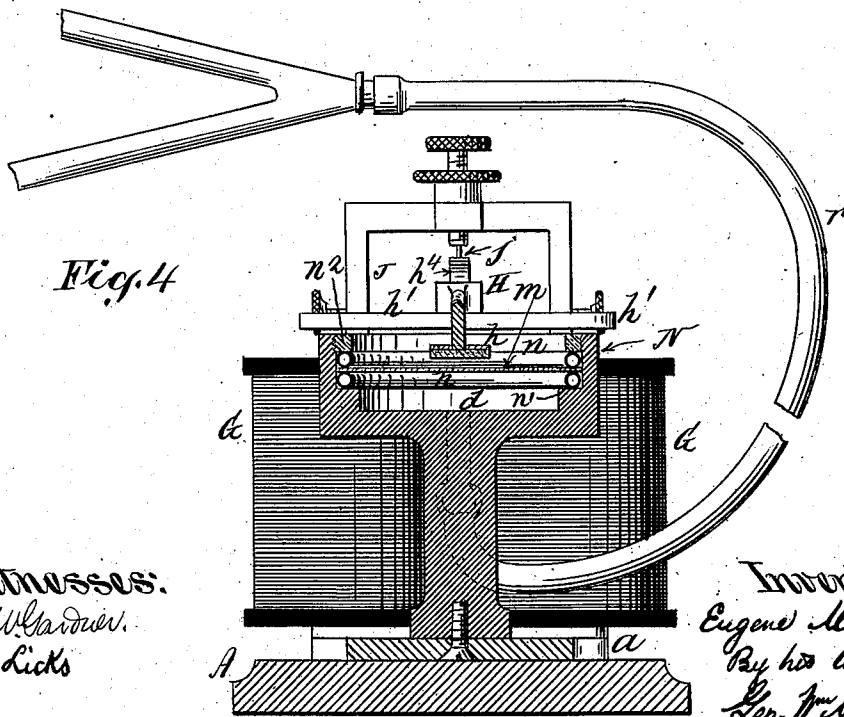
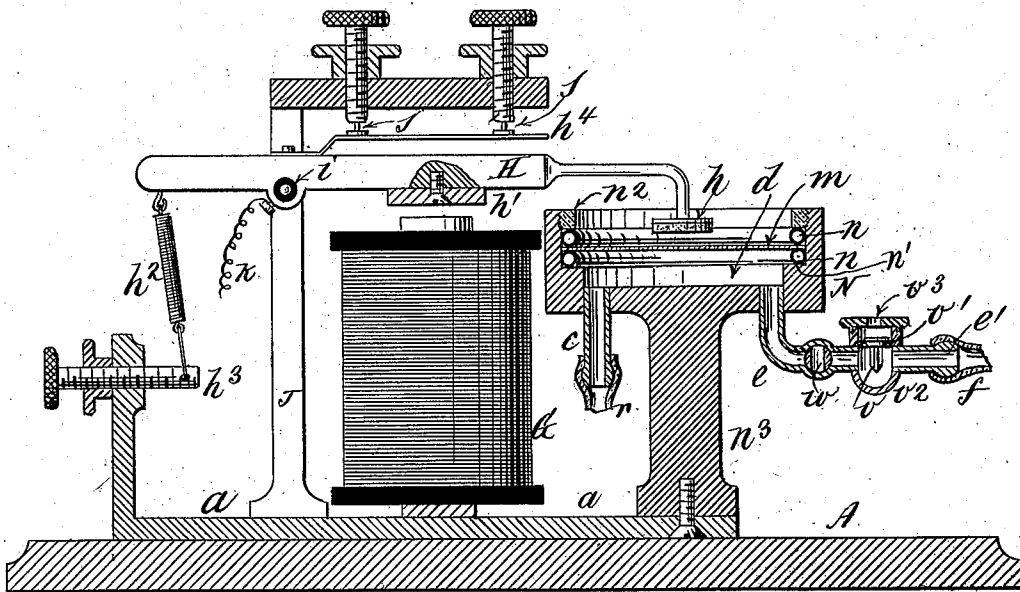

Witnesses:
W. L. Gardner.
G. Licks

Inventor:
Eugene Meyer
 By his attorney
Geo. W. Minto

BEST AVAILABLE COPY

UNITED STATES PATENT OFFICE.

EUGENE MEYER, OF NEW YORK, N. Y.

VIBRATORY APPARATUS FOR EAR TREATMENT.

No. 853,645.

Specification of Letters Patent.

Patented May 14, 1907.

Application filed December 24, 1906. Serial No. 349,312.

To all whom it may concern:

Be it known that I, EUGENE MEYER, a citizen of the United States, residing in the borough of Manhattan, city, county, and State of New York, have invented certain new and useful Improvements in Vibratory Apparatus for Ear Treatment, of which the following is a specification.

My improvements relate to apparatus for treating the tympanum of the ear to air pulsations or vibrations for remedial purposes and the invention consists in the special arrangement and combination of parts herein described and claimed.

In the accompanying drawings, Figure 1, is a side elevation of my apparatus; Fig. 2, is a plan of the same; Fig. 3, a central longitudinal sectional elevation upon plane of line 3—3—Fig. 2; Fig. 4, is a section upon plane of line 4—4—Fig. 2;

The diaphragm *m*, is preferably, though not necessarily, made of mica on account of its resilience, durability and unchangeability under changes of temperature and atmospheric conditions. It is preferably of circular form and its edges are supported by and between annular gaskets *n*, *n*, which may consist of rubber tubing as indicated in Figs. 3 and 4,—the lower gasket resting upon an annular shoulder *n'*, in the air chamber *d*, and the upper gasket being confined by an annular peripherally threaded ring *n²*, screwing into the upper edge of the air cup *N* in which the air or diaphragm chamber *d*, is formed. The air cup *N* is shown as supported upon a standard *n³*, attached to the plate *a*, which is in turn rigidly secured to the base *A*.

c, is a pipe or nipple extending through the bottom of the air cup *N* and communicating with the air chamber *d*. To this nipple *c*, is attached a rubber tube *r*, or equivalent for conveying the air pulsations created by the vibration of the diaphragm *m*, to the ear or ears, or nostril or nostrils of the patient, as the case may require. Obviously the outer end of this tube *r*, may be bifurcated, and it may be provided with a nozzle or nozzles *r'*, for direct and air tight contact with the ear or nasal passages. Another tube *e*, protrudes from the bottom of the air cup *N*, communicating with the diaphragm cham-

ber *d*, therein, as shown in Fig. 3, and in this tube *e*, and between the air cup *N* and the nipple *e'*, of the tube *e*, is interposed a small puppet valve *v*, resting normally on a seat *v'*, in the casing *v²*, and movable between said seat *v'*, and the aperture *v³*, in the top of the casing *v²*. A stop cock *w*, is interposed in the pipe *e*, between the air cup *N* and the valve *v*, so that the latter may be cut out when desired. Attached to the nipple *e'*, is a flexible tube *f*, upon the other end of which is a rubber bulb or equivalent *F*. It will be seen that the valve *v*, may be designed as a double acting since it performs the double function of a relief and a check valve.

As shown in the drawings the hammer *h*, is made to reciprocate by electromagnetism,—said hammer being attached to the free end of a lever *H* carrying an armature *h'*, opposed to the cores of two electro-magnets *G*, *G*. The rear end of the armature lever *H* is connected with a spring *h²*, which is in turn connected with an adjusting screw *h³*, by which the tension of the spring may be regulated. The lever *H* is insulated from its fulcrum by a sleeve or bushing of insulating material *i*, shown in Fig. 3, and carries a contact breaker *h⁴*, of any desired or well known construction.

B is a battery or other source of electrical energy controlled by a switch *S*. The current, when turned on passes through the coils of the electro-magnets *G*, *G*, to the standard *J* and through the latter to the contacts *j*, *j*, and through them to the contact breaker *h⁴*, and lever *H* from which the circuit is completed through the connection *k*,—the current being alternately opened and closed by the action of the electro-magnets in the usual and well known manner. As a result the air within the chamber *d*, is alternately compressed and relaxed and the pulsations or variations in density or pressure are transmitted through tubing *r*, to the nozzle or nozzles *r'*, the cock *w*, being preferably closed.

When it is desired to vary the pressure above or below normal or atmospheric pressure, the cock *w*, is opened, so as to render the valve *v'*, available. Under these conditions, if the bulb *F* is collapsed slowly the excess of air will raise the valve *v*, slightly from its seat *v'*, and allow such excess to escape

without perceptibly affecting the air in the diaphragm chamber *d*. If now the bulb be released its automatic expansion will cause suction which will hold the valve *v*, on its seat *v'*; and create a partial vacuum within the air chamber *d* which of course, creates suction in the tube *r*. If, on the contrary, it is desired to create an excess of pressure within the diaphragm chamber *d*, and tube *r*, the bulb *F* is compressed forcibly and rapidly, immediately driving the valve *v*, upward, closing the aperture *v''*, and forcing an excess of air into said diaphragm chamber *d* and tubing *r*. By these various manipulations I am enabled to adapt and modify the action of my apparatus to the special requirements of patients under treatment. Thus if the ear drum is collapsed or drawn inward, the partial vacuum or suction treatment is resorted to through the external ear passages, whereas if the tympanum is distended outward for any reason an excess of pressure is utilized in like manner. Or the reverse treatment may be resorted to in like cases where the treatment is administered through the nasal passages and eustachian ducts.

I have found by actual experience that my apparatus may be effectually used to relieve tinnitus aurium or "head noises," to exercise and strengthen the tympanum and remedy or correct its position &c. It has been found efficient in returning and even curing partial and prolonged deafness; and may be used advantageously in loosening waxy deposits within the inner ear. In fact, owing to the elasticity and resilience of the air it may be thus used where resort to more positive rigid means would be inexpedient or dangerous.

My apparatus is especially advantageous and useful in substituting elastic fluid air in lieu of liquids in the treatment of the ear, since the practically incompressible liquids are apt to cause inflammation or even rupture unless skilfully used, and in cases where the eustachian tube is wholly or partially closed my apparatus furnishes the only available means of effective treatment.

What I claim as my invention and desire to secure by Letters Patent is,

1. In apparatus of the character designated, the combination of an air chamber, a diaphragm therein, means for forcing air under pressure into said air chamber, means for vibrating said diaphragm consisting of a vibratory hammer lever provided with an armature actuated by electro magnetism, and means for transmitting the resultant vibrations of air to a patient, substantially in the manner and for the purpose described.

2. In apparatus of the character designated, the combination of an air chamber, a diaphragm therein, means for withdrawing air from said air chamber for the purpose of

reducing the tension in said chamber below atmospheric pressure, means for vibrating said diaphragm consisting of a vibratory hammer lever provided with an armature actuated by electro magnetism, and means for transmitting the resultant vibrations of rarefied air to a patient, substantially as set forth.

3. In apparatus of the character designated, the combination of an air chamber, a collapsible bulb connected with said air chamber, a relief and check valve interposed between said air chamber and said bulb, a diaphragm in said air chamber means for vibrating said diaphragm consisting of a vibratory hammer lever provided with an armature actuated by electro-magnetism, and means for transmitting the resultant vibrations of air to a patient, substantially in the manner and for the purpose described.

4. In apparatus of the character designated, the combination of an air chamber, means for exhausting air therefrom, a relief and check valve interposed between said air chamber and said means of exhaust, a diaphragm in said air-chamber, means for vibrating said diaphragm consisting of a vibratory hammer lever provided with an armature actuated by electro-magnetism, and means for transmitting the resultant vibrations of air to a patient, substantially in the manner and for the purpose described.

5. In apparatus of the character designated, the combination of an air chamber, a diaphragm therein, means for vibrating said diaphragm consisting of a vibratory hammer lever provided with an armature actuated by electro-magnetism, and means for transmitting resultant vibrations of air to a patient, substantially in the manner and for the purpose described.

6. In apparatus of the character designated, the combination of an air chamber, a collapsible bulb connected with said air chamber, a check valve interposed between said air chamber and said bulb, a stop cock interposed between said air chamber and said check valve, means for vibrating said diaphragm and means for transmitting the resultant vibrations of air to a patient, substantially in the manner and for the purpose described.

7. In apparatus of the character designated, the combination of an air chamber, means for exhausting air therefrom, a relief valve interposed between said air chamber and said means of exhaust, a stop cock interposed between said air chamber and said relief valve, a diaphragm in said air chamber, means for vibrating said diaphragm, and means for transmitting the resultant vibrations of air to a patient, substantially in the manner and for the purpose described.

8. In apparatus of the character designated, the combination of an air chamber

means for exhausting air therefrom, a check
valve interposed between said air chamber
and said means of exhaust, a stop cock inter-
posed between said air chamber and said
5 check valve, a diaphragm in said air cham-
ber, means for vibrating said diaphragm, and
means for transmitting the resultant vibra-

tions of air to a patient, substantially in the
manner and for the purpose described.

EUGENE MEYER.

Witnesses:

D. W. GARDNER,
GEO. WM. MIATT.