

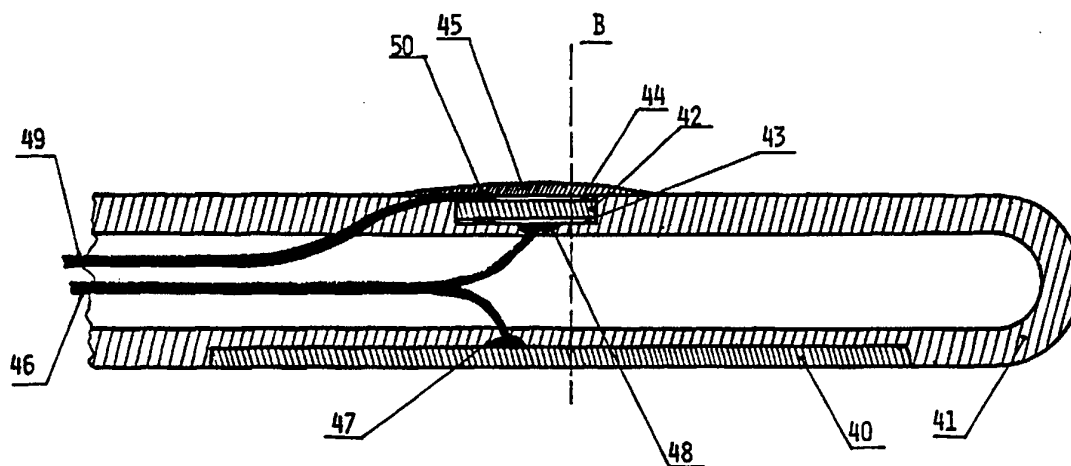

INTERNATIONAL APPLICATION PUBLISHED UNDER THE PATENT COOPERATION TREATY (PCT)

<p>(51) International Patent Classification ⁶ : A61B 17/39, 8/12</p>	<p>A1</p>	<p>(11) International Publication Number: WO 95/17131</p> <p>(43) International Publication Date: 29 June 1995 (29.06.95)</p>
<p>(21) International Application Number: PCT/EP94/04252</p> <p>(22) International Filing Date: 21 December 1994 (21.12.94)</p> <p>(30) Priority Data: P 931513 A 22 December 1993 (22.12.93) HR P 931514 A 22 December 1993 (22.12.93) HR</p> <p>(71) Applicant (for all designated States except US): MONAMED MEDIZINTECHNIK GMBH [DE/DE]; Raiffeisenallee 6, D-82033 München (DE).</p> <p>(71)(72) Applicants and Inventors: FERЕК-PETRIC, Bozidar [HR/HR]; Sovenic 17, 41000 Zagreb (HR). BREYER, Branko [HR/HR]; Prilaz G. Dezelica 79, 41000 Zagreb (HR). CIKES, Ivo [HR/HR]; Novakova 17, 41000 Zagreb (HR).</p> <p>(74) Agent: BLUMBACH WESER BERGEN KRAMER ZWIRNER HOFFMANN HERDEN KOEPE; Radeckestrasse 43, D-81245 München (DE).</p>		<p>(81) Designated States: JP, US, European patent (AT, BE, CH, DE, DK, ES, FR, GB, GR, IE, IT, LU, MC, NL, PT, SE).</p> <p>Published <i>With international search report. Before the expiration of the time limit for amending the claims and to be republished in the event of the receipt of amendments.</i></p>

(54) Title: ULTRASONIC MARKED CARDIAC ABLATION CATHETER



(57) Abstract

An elongated catheter body (41) for implantation in the human heart comprises an ablation electrode (40) adapted to be connected to the heart and an ultrasonic transducer assembly (42) at a location adjacent to said ablation electrode. Said transducer assembly is adapted to produce a directional acoustic ultrasonic field when supplied with a high frequency electrical signal and said ablation electrode is adapted to produce a directional electric ablation field when supplied with an ablation signal. The ablation energy source can be controlled in such a way as to deliver the energy only if the ablation electrode is in an intimate contact with the tissue.

FOR THE PURPOSES OF INFORMATION ONLY

Codes used to identify States party to the PCT on the front pages of pamphlets publishing international applications under the PCT.

AT	Austria	GB	United Kingdom	MR	Mauritania
AU	Australia	GE	Georgia	MW	Malawi
BB	Barbados	GN	Guinea	NE	Niger
BE	Belgium	GR	Greece	NL	Netherlands
BF	Burkina Faso	HU	Hungary	NO	Norway
BG	Bulgaria	IE	Ireland	NZ	New Zealand
BJ	Benin	IT	Italy	PL	Poland
BR	Brazil	JP	Japan	PT	Portugal
BY	Belarus	KE	Kenya	RO	Romania
CA	Canada	KG	Kyrgystan	RU	Russian Federation
CF	Central African Republic	KP	Democratic People's Republic of Korea	SD	Sudan
CG	Congo	KR	Republic of Korea	SE	Sweden
CH	Switzerland	KZ	Kazakhstan	SI	Slovenia
CI	Côte d'Ivoire	LI	Liechtenstein	SK	Slovakia
CM	Cameroon	LK	Sri Lanka	SN	Senegal
CN	China	LU	Luxembourg	TD	Chad
CS	Czechoslovakia	LV	Latvia	TG	Togo
CZ	Czech Republic	MC	Monaco	TJ	Tajikistan
DE	Germany	MD	Republic of Moldova	TT	Trinidad and Tobago
DK	Denmark	MG	Madagascar	UA	Ukraine
ES	Spain	ML	Mali	US	United States of America
FI	Finland	MN	Mongolia	UZ	Uzbekistan
FR	France			VN	Viet Nam
GA	Gabon				

ULTRASONIC MARKED CARDIAC ABLATION CATHETER

Technical Field

5

This invention relates to the therapy of cardiac arrhythmias particularly to the system for ablation of the cardiac conduction tissue for the objective of cessation of the cardiac arrhythmia. More particularly, the invention pertains to the system for ablation by means of directional electric field as well as for the orientation of the ablation electrode within the heart. This invention also relates to monitoring of the contact between the ablation electrode and the cardiac tissue.

10

Background and Prior Art

Tachycardia is the condition of the accelerated pulse rate. Natural tachycardia occurs in physical exercise and emotional stress because of the sympathetic nervous tone and increase of the circulatory catecholamines concentration. The most important quality of the natural tachycardia is the increase of the cardiac output. Pathologic tachycardia is the one which impedes the hemodynamics of the heart i.e. decrease of the cardiac output occurs. The electrophysiology discriminates two major classes of tachycardia: supraventricular and ventricular, as well as two major classes of etiology: ectopic focuses and reentry phenomena. The therapy of tachycardia is in principle either the suppression of ectopic focuses or interruption of the reentry pathway. The first access is always the pharmacotherapy. Despite of the recent advances in electropharmacology, every antiarrhythmic drug is not effective in every patient. Drugs also provoke the side effects which can be hazardous to the patient. Therefore more invasive modes of therapy must be encountered like surgical treatment and permanent implantation of an electrotherapy device. The method of choice is the ablation which is a semi-invasive interventional method.

20

25

Transvenous catheter ablation of cardiac conduction tissue is a low risk alternative to

30

surgical ablation to achieve a goal to control refractory supraventricular tachyarrhythmias. Some positive results have been also acquired in the treatment of ventricular tachycardia. The principal energy source for catheter ablations is a DC energy pulse from a standard defibrillator. In order to minimize the energy for the purpose of safety, numerous
5 modifications in design of the energy source as well as of the catheter have been realized. In order to achieve the controllability of the lesion size as well as to avoid hazardous shock wave, the radiofrequency energy source has been introduced. For the same reason, the laser ablation fiberoptic catheters have been developed. The application of microwave energy is an alternative method, as well as the ablation by means of the chemical agents.

10

One of the problems in ablation is the exact positioning of the ablation electrode within the heart. The procedure is normally controlled by means of the radiographic imaging. Recent investigations proved that X-ray radiation exposure is significant and may be hazardous (H.Calkins et al.: "Radiation Exposure During Radiofrequency Catheter Ablation of
15 Accessory Atrioventricular Connections." *Circulation* 1991;84:2376-2382.). Disadvantage of X-ray methods is the poor imaging of soft tissues, i.e. papillary muscle, interventricular septa, and so forth. As an alternative, ultrasonic imaging is well suited for imaging of soft tissues, but has the disadvantage of imaging in one plane tomographically. The ultrasonically marked catheters and cardiac pacing leads have been described in the
20 U.S.Pat.No. 4,697,595 and in the U.S.Pat.No. 4,706,681 respectively. Such systems enable the echocardiographic guidance of the procedure as well as the exact localization of the lead tip. If the ablation electrode is marked by an ultrasonic transducer, the exact position of the ablation electrode can be identified. As far as it is known to the inventors, none of the systems enables the radial orientation of the catheter.

25

The majority of ablation catheters comprise ring electrodes producing the axial symmetric field. Therefore dissipation of the ablation energy occurs in the vicinity of the electrode, and only a small portion of the electric field penetrating towards the tissue is efficient. Platelet electrodes mounted on the one side of the catheter body produce directional
30 electric field, but the problem of radial orientation of the catheter occurs. Position of the

electrode cannot be monitored by means of the X-ray imaging. It is therefore important to obtain the method of confirmation of directional electric field orientation towards the tissue.

5 In order to use the maximal amount of ablation electric field, the ablation electrode must have an intimate contact with the cardiac tissue. Because of the cardiac contractions, dislodgement of the electrode from desired position occurs. Electrophysiologists usually monitor the intracardiac potentials to confirm the proper position as well as the proper contact of the electrode with the endocardium. However, the intracardiac potential is
10 discontinuous being characterized with intrinsic deflection which is repetitive at the frequency of the heart beats. Distinct ST elevation caused by the injury current confirms the pressure of the electrode to the cardiac muscle. However, dislodgement may also occur anywhere within the cardiac cycle while there is no intracardiac signal. There is a system available on the market (Made by Dr.Osypka GmbH) which monitors the impedance of the
15 ablation electrode as an indirect parameter for contact monitoring. As far as it is known to the inventors, none of the available systems enables the continuous monitoring of the distance between the electrode and the endocardial cardiac tissue.

Summary of the Invention

20

It is a principle object of this invention to provide a system for ablation procedure with the ultrasonically marked catheter comprising means for determination of radial orientation as well as the means for directional field ablation.

25

It is a particular object of this invention to provide means for determination of the ablation field direction within the heart by means of ultrasonic imaging.

30

In accordance with a first aspect of the invention, the ablation catheter comprises an ablation electrode producing directional electric field as well as an ultrasonic marking transducer mounted fixedly in the vicinity of the ablation electrode having directional

ultrasonic sensitivity characteristics either in the same direction as the ablation field or in some another direction determined by a certain defined angle relatively to the direction of the ablation field.

- 5 It is a further object of the invention to provide means for measuring distance of the ablation electrode from the cardiac tissue and means for modulation of the ablation energy source in such a way as to deliver the energy only if the electrode is in the intimate contact with the tissue.
- 10 In accordance with further aspect of the invention, an ultrasonic apparatus comprises the electronic circuits capable to measure the distance of the ablation electrode from the tissue as well as to switch on the ablation energy source whenever the electrode is sufficiently close to the tissue. An energy control means may be provided for changing the power of the ablation in response to an output from the proximity measurement means. Further
- 15 objects, features and advantages of the invention will become apparent upon consideration of the following detailed description in conjunction with the drawings, in which:

Fig. 1 is a perspective view of an ultrasonically marked ablation catheter providing opposite directions of ultrasonic and electric fields.

20

Fig. 2 is a schematic disclosure of application of the catheter from previous figure within the heart.

Fig. 3 is a radial plane cross-section of the same catheter at the site of the electrode and ultrasonic transducer.

25

Fig. 4 is an axial cross-section of the same catheter at the same site.

Fig. 5 is a perspective view of an ultrasonically marked ablation catheter providing identical direction of electric and ultrasonic fields.

30

- Fig. 6 is a schematic disclosure of application of the catheter from previous figure within the heart.
- Fig. 7 is a perspective view of an ultrasonically marked ablation catheter providing omnidirectional ultrasonic and directional electric field.
- Fig. 8 is a cross-section of the catheter from previous figure at the site of the ultrasonic transducer.
- Fig. 9 is a view on the omnidirectional ultrasonic transducer assembly and ablation electrode surface.
- Fig. 10 is an axial cross-section of the catheter at the site of the ultrasonic transducer attachment.
- Fig. 11 shows the waveforms of the A-mode ultrasonic signal, the ECG and the ablation power, disclosing the principle of the proximity monitoring and power modulation.

Description of the Preferred Embodiment

Referring to figure 1 there is shown a distal part of a catheter comprising a plastic body 10. Adjacent to the catheter tip 11 there is an ablation electrode 12. The ablation electrode 12 is a plate having the maximal width of approximately the quarter of the catheter body circumference. Such an electrode generates directional electric field which penetrates to the side where the electrode is mounted fixedly. It is disclosed that the electrode 12 is embedded within the catheter body 10, but it may be also fixed on the body surface. Disclosed electrode mounting mode is preferable because of the ease of catheter insertion within the blood vessel. At the opposite side to the electrode, an ultrasonic marking transducer assembly 13 is mounted fixed in such a way as to generate the ultrasonic field

which is opposite to the electric field for the ablation.

Referring to figure 2 there is disclosed a schematic cross-section through the left posterior heart. The left atrial cavity 20 and the left atrial posterior wall 21 are disclosed as well as the left ventricular cavity 23 and the left posterior ventricular wall 25. Between the atrial cavity 20 and the ventricular cavity 23, there is a fibrous annulus 24 of the mitral valve (not shown), the coronary sinus 22 being posteriorly. The oesophagus 26 is in the intimate contact with the left atrial posterior wall 21. The transoesophageal echocardiography probe 27 is inserted within the oesophagus 26. An ultrasonically marked catheter 28, such as described in previous figure, is implanted within the coronary sinus 22. The catheter 28 generates the ultrasonic field 29 as well as the ablation electric field 30. Disclosed arrangement illustrates the correct position of the ablation catheter such as to obtain the mark on the echocardiographic image by means of the transoesophageal probe 27 and directional ultrasonic field 29. At the opposite side of the catheter, the ablation field 30 is directed towards the fibrous annulus 24 wherein the accessory pathway should be ablated for treatment of supraventricular tachycardia. Radial twisting of the catheter can change direction of both fields and, by means of the transoesophageal echocardiography imaging, the ablation field can be directed towards preferred cardiac tissue volume. Another ablation catheter 31 is implanted within the left ventricle for the treatment of ventricular tachycardia. Catheter 31 generates an ultrasonic marking field 32 directed anteriorly as well as an ablation electric field 33 directed towards the left ventricular posterior wall 25. By means of the radial twisting of the catheter 31 and two dimensional transthoracic echocardiographic imaging, the ablation field 33 can be directed towards preferred volume of the ventricular wall 25.

Referring to figure 3, the radial cross-section of the catheter from figure 1 is disclosed without necessary electrical connections. The ablation electrode 34 is a metal plate embedded within the contours of the hollow plastic catheter body 35. An ultrasonic marking transducer 36 is mounted fixedly at the opposite side to the electrode 34. Transducer 36 is disclosed to be a piezoelectric platelet comprising metallized layers 37 and 38 which are the transducer electrodes. An ultrasonically matched layer 39 covers the

transducer 36 for the purpose of electric insulation as well as mechanical and chemical isolation. Dashed line A designates the axial cross-section of the next figure.

Referring to figure 4, there is disclosed an axial cross-section of the distal part of a catheter from previous figures, as defined by dashed line A in figure 3. Dashed line B designates the radial cross-section disclosed in previous figure 3. The ablation electrode 40 is mounted fixedly embedded within the plastic hollow catheter body 41. Piezoelectric platelet 42 comprises metallized layers 43 and 44 being the ultrasonic transducer electrodes. Transducer 42 is mounted fixedly within the catheter body 41 and is covered by an ultrasonically matched insulation layer 45. Electric wire 46 is bifurcated at its distal end and soldered to the electrode 40 by means of the soldering joint 47 as well as to the transducer electrode 43 by means of the soldering joint 48. Electric wire 49 is soldered to the transducer electrode 44 by means of the soldering joint 50. In disclosed electric connection, the ultrasonic signal is led through wires 46 and 49, while the ablation energy is delivered through the wire 46. Instead of the soldering joints, the conductive gluing is also applicable. Disclosed ablation catheter assembly is the illustration of the one possible embodiment. There is no limitation to use the same principle in multiluminal catheter tubes. For the purpose of either radiofrequency or microwave energy ablation, the catheter wires will be specially designed to be coaxial in order to prevent the energy losses and dissipation within the catheter as well as to prevent the interference between ultrasonic circuit and ablation circuit.

Referring to figure 5, there is disclosed a distal portion of an ablation catheter capable to generate directional ultrasonic marking field as well as directional ablation field directed to the same direction. The catheter comprises a metal plate 55 being the ablation electrode, mounted fixed at the tip 56 of the catheter body 57. Adjacent to the electrode 55, there is a marking transducer assembly 58.

Referring to figure 6, there is disclosed a schematic illustration of the application of the catheter similar to that disclosed in figure 5. The catheter 60 is implanted at the cardiac

muscle wall 61. For the purpose of illustration of another possible arrangement of that in figure 5, the marking transducer assembly 62 is mounted fixedly adjacent to the catheter tip 63. Ablation electrode 64 is mounted fixedly proximate to the marking transducer assembly 62. Unidirectional fields are generated: the ultrasonic one 65 for the purpose of marking as well as the electric one 66 for the purpose of tissue ablation within the myocardial wall 61.

Referring to figure 7, there is disclosed a distal portion of an ablation catheter capable to generate omnidirectional as well as directional fields for ultrasonic marking, and a directional electric field for ablation. An ablation electrode 70 being a metal plate is mounted fixedly embedded within the catheter plastic body 71. The marking transducer assembly 72 is mounted fixedly at the tip 73 of the catheter.

Referring to figure 8, the radial cross-section of the marking transducer assembly is disclosed. Transducer assembly consists of the four piezoelectric segments 75, 76, 77 and 78 mounted fixedly by means of the soldering joint 79 to the reinforcement tube 80. Piezoelectric segments are disclosed to be cut from the tubiform piezoelectric transducer. In another possible embodiment (not shown), it is also convenient to use the four piezoelectric platelets. Piezoelectric transducers comprise their electrodes which are the metallized layers: transducer 75 has electrodes 81 and 82, transducer 76 has electrodes 83 and 84, transducer 77 has electrodes 85 and 86, and transducer 78 has electrodes 87 and 88. The transducer segments are fixed to the metal reinforcement tube 80 actually with their electrodes 81, 83, 85 and 87, being soldered by means of the soldering joint 79. Therefore the reinforcement tube 80 is also the common electric connection for all four transducer segments. Transducer assembly is covered by means of an insulating ultrasonically matched thin layer 89.

Referring to figure 9, there is disclosed how the reinforcement tube 90 (designated by 80 in previous figure) mechanically connects the tip 91 of the catheter with the proximal part 92 of the catheter. The metal plate electrode 93 for ablation is mounted fixedly adjacent

to the marking transducer assembly which is disclosed without the ultrasonically matched insulative layer to illustrate the details of the mounting rig. In this projection, only three transducer segments can be disclosed comprising piezoelectric segment 94 with its external transducer electrode 95, piezoelectric segment 96 with its external transducer electrode 97, as well as the transducer electrode 98 of the third piezoelectric segment which cannot be disclosed from this angle of view. Insulated wire 99 is conducted through the hole 100 (drilled on the reinforcement tube 90), and soldered to the transducer electrode 98 by means of the soldering joint 101. Another wire 102, emanating through the reinforcement tube 90, is soldered to the transducer electrode 95 by means of the soldering joint 103. The third wire 104, emanating through the reinforcement tube 90, is soldered to the transducer electrode 97 by means of the soldering joint 105. The dashed line of cross-section for the next figure is designated by C.

Referring to figure 10, there is disclosed the axial cross-section through the reinforcement tube 110 (designated with 90 in figure 9 and with 80 in figure 8). The marking transducer segments are not mounted in order to illustrate the preparation of electric connections and conduction of wires through the reinforcement tube. The distal part 111 of the catheter body, which is actually close to the catheter tip, is mechanically fixed to the reinforcement tube 110 by means of the adhesive layer 112. The proximal part 113 of the catheter body is mechanically fixed to the reinforcement tube 110 by means of the adhesive layer 114. The ablation electrode 115 is mounted fixedly on the hollow plastic body 113. An uninsulated wire 116, bifurcated at its distal end is electrically connected to the reinforcing tube 110 by means of the soldering joint 117, as well as to the electrode 115 by means of the soldering joint 118. Insulated wire 120 is prepared for the soldering with its uninsulated end 121 to the external transducer electrode of one piezoelectric segment (not shown), and is conducted through the hole 122 in the reinforcement tube 110. Insulated wire 123 is prepared for the soldering with its uninsulated end 124 to the external transducer electrode of one piezoelectric segment (not shown), and is conducted through the hole 125 in the reinforcement tube 110. Insulated wire 126 is prepared for the soldering with its uninsulated end (not shown) to the external transducer electrode of one

piezoelectric segment (not shown), and is conducted through the hole 127 in the reinforcement tube 110. The fifth wire is not shown in this projection.

In disclosed embodiment of figures 7, 8, 9 and 10, the marking transducer segments may
5 be separately connected to the ultrasonic marking circuits by means of the common wire 116 and special four wires connected to the external transducer electrodes. If all four segments are connected to the marking circuits simultaneously, the omnidirectional ultrasonic field assures the proper marker for the purpose of implantation guidance. If one
10 of the segments is connected to the marking circuits, directional ultrasonic field enables the marker for the purpose of determination of the radial orientation of the electrode. Moreover, switching different single segment enables four different marker radial positions: at the ablation electrode, opposite to the ablation electrode, and two positions at
15 90 degrees to the ablation electrode. For example, if the wire 99 and reinforcement tube 90 (disclosed in figure 9) are connected to the ultrasonic marking circuit, the marker occurs when the ablation electrode 93 is orientated towards the scanner probe. It is understood that other modes of electrical connections are possible, specially in multiluminal catheter bodies and by means of the coaxial cables. However, the principle remains always the same as disclosed herein.

20 Referring to figure 11, there is disclosed the principle of the proximity modulation of the radiofrequency ablation power. The ultrasonic field 65 produced by transducer 63, as designated in figure 6, may be used for monitoring of the distance between transducer 63 and myocardial wall 61. This distance actually represents also the distance between
25 ablation electrode 64 and myocardial wall 61.

It is known in the art that the electric field strength decreases with the square of the distance. Therefore every ablation electrode dislodgement i.e. increase of the distance between ablation electrode and cardiac tissue, causes significant losses of ablation energy, as well as dissipation in the surrounding blood and tissue which may cause blood
30 coagulation and thromboembolic incident.

Directional marking transducer may be connected to the echocardiographic scanner for instance with passive system for marking purpose in 2D image and ultrasonically guided implantation of the catheter. Within the A-mode echographic circuits, the signal may be obtained as disclosed on diagram of figure 11. First echo signal peak 150 is the echo from the myocardial wall wherein exists the tissue intended for ablation. Second echo signal peak 151 is the signal of the marker transducer. This second signal peak is rhythmically shifted in the left-right manner, as the cardiac contraction provokes the catheter tip movement and consequent microdislodgement. The signal peak 151 is disclosed in the moment of maximal distance of the marker transducer from the myocardium. Dashed contour 152 represents the position of the echo signal peak 151 in the moment when the marking transducer remains in the intimate contact with the myocardium. Dashed lines 153 represent the magnitude of the electrode dislodgement. Catheter dislodgement is rhythmic i.e. the movements of the catheter within the heart are synchronous with certain mechanical event within the cardiac cycle. Catheter may move either during the cardiac contraction, or during the cardiac relaxation. The mode of catheter movement is a consequence of unforeseen events, but it is usually synchronous with ECG signal. Therefore the waveform of the proximity 155 as a function of time of the marking transducer relatively to the myocardial wall is shown in timing correlation with ECG waveform 154. Dotted line 156 depicts the trigger level for the proximity switch of the radiofrequency ablation energy source. The waveform 157 of the radiofrequency power (designated by "RFP") as a function of time (designated by "T") is disclosed in exact timing correlation with the proximity waveform 155. Whenever the proximity value between the marking transducer and the myocardial wall falls below the trigger level determined by line 156, the radiofrequency power is switched-on (158). Whenever the proximity value between the marking transducer and the myocardial wall raises above the trigger level determined by line 156, the radiofrequency power is switched-off (159). In this mode of operation, the radiofrequency energy source generates a periodic waveform of the power which is synchronous with the cardiac mechanical events.

If a DC shock is used for ablation procedure, the same principle may be used for firing the

defibrillator pulse synchronously with the QRS complex but in connection with the proximity switch i.e. during the period when the proximity value is small. Actually this means that the QRS detector signal (having logical "1" during the QRS duration) and proximity detector (having logical "1" when function 155 is bellow trigger level 156) signal must be processed by means of the Boolean AND gate in order to get the logical "1" to fire the defibrillator pulse.

While specific embodiments of present invention have been described, it should be understood that these embodiments are described for purposes of illustration only. The foregoing description is not intended in any way to limit the scope of the present invention. Rather is the intention that the scope of the invention be limited only as defined in the appended claims.

Claims

1. A cardiac ablation device comprising
 - an elongated catheter body (10, 28, 31, 35, 41, 57, 60, 71) for implantation in the human heart, having an ablation electrode (12,34, 40, 55, 64, 70) adapted to be
5 connected to the heart;
 - said catheter body including an ultrasonic transducer assembly (13, 36, 42, 58, 62, 72) at a location adjacent to said ablation electrode;
 - said catheter body comprising two conductors (46, 49) which are provided with terminals at the proximal end of the catheter and adapted to transmit the high
10 frequency electrical signal to said transducer assembly (42) and vice versa, whereby one of said conductors (46) is adapted to transmit the ablation signal to said electrode (40);
 - said transducer assembly (13, 36, 42, 58, 62, 72) being adapted to produce a directional acoustic ultrasonic field (29, 32, 65) when supplied with said high frequency electrical signal and said ablation electrode (12, 34, 40, 55, 64, 70) being adapted to
15 produce a directional electric ablation field (30, 33, 66) when supplied with said ablation signal;
 - said transducer assembly and said ablation electrode being arranged in a predetermined mutual positional relationship so that the direction of said electric ablation field is exactly determined relative to the direction of said acoustic ultrasonic field.
20
2. Device according to claim 1, wherein direction of said electric ablation field (30) can be determined within the structures of the heart whenever direction of said acoustic field (29) within the structures of the heart is determined by means of processing of said electrical signal from said ultrasonic field, said processing providing the marker
25 within an echocardiographic image pointing the direction of said acoustic field towards the echocardiographic scanner probe (27).
3. Device according to claim 1 or 2, wherein said ablation electrode (12, 34, 40, 55, 64, 70) is a plate of a maximum width of one quarter of the circumference of said
30 catheter body.

4. Device according to any of claims 1 to 3, wherein said transducer assembly (13, 36, 42, 58, 62) comprises a platelet of a width of approximately one quarter of the circumference of said catheter body, and which is made of piezoelectric material having two metallized layers (37/38, 43/44) being the transducer electrodes polarizing said transducer in radial direction relatively to said catheter body.

5. Device according to any of claims 1 to 4, having said electrode and said transducer assembly positioned near the tip of said catheter body (11, 56, 63, 73).

10

6. Device according to any of claims 1 to 5, wherein the mutual distance between the said ablation electrode and the said ultrasonic transducer assembly is less than half of the length of said transducer assembly.

15

7. Device according to any of claims 1 to 6, wherein the axis of the directivity of said electric ablation field (66) and the axis of the directivity of said acoustic ultrasonic field (65) coincide.

8. Device according to any of claims 1 to 6, wherein the axis of the directivity of said electric ablation field (30, 33) and the axis of the directivity of said acoustic ultrasonic field (29, 32) are at any fixed azimuthal angle including 180 degrees.

20

9. Device according to any of claims 4 to 8, wherein said transducer assembly is a platelet having width and length such as to generate a directive characteristic (29, 32, 65) at its operation frequencies, the directivity of the main lobe not exceeding 60 degrees.

25

10. Device according to any of claims 4 to 9, wherein said piezoelectric platelet (36, 42) is covered on the outer side by an insulating and isolating layer (39, 45).

30

11. Device according to any of claims 1 to 10, wherein said electrode and said

transducer assembly do not protrude unessentially from the outside profile of said catheter body.

12. Device according to any of claims 1 to 11, wherein said transducer
5 assembly comprises a cylindrical array of piezoelectric transducers (75, 76, 77, 78) facing in all azimuthal directions.

13. Device according to claim 12, wherein each of said piezoelectric
transducers (75, 76, 77, 78) comprises two metallized layers (81/82, 83/84, 85/86, 87/88)
10 being the transducer electrodes polarizing said transducers in radial direction relatively to said catheter body.

14. Device according to claim 12 or 13, wherein said transducers (75, 76, 77,
78) are fixed onto a reinforcement tubelet or rig of other form (80, 90) by means of the
15 conductive adhesive joint (79) which electrically connects the inner array of said transducer electrodes (81, 83, 85, 87) with said reinforcement (80, 90).

15. Device according to any of claims 12 to 14, wherein said transducers of
said array are connected to the proximal end of said catheter body via lengthwise
20 conductors (99, 102, 104) running along and inside of the said catheter body and being connected to outer array of said transducer electrodes (98, 95, 97) by means of joints (101, 103, 105), said conductors being adapted to transmit high frequency ultrasonics signals to said transducer array and vice versa, in such a way as that the signal of each single transducer of said transducer array is provided between said reinforcement and each
25 single of said lengthwise conductors respectively.

16. Device according to any of claims 1 and 15 further comprising
an electronic circuit means connectable or connected to said ablation electrode
and to said transducer assembly, capable of transmitting signals into and receiving signals
30 from said transducer assembly and said ablation electrode, in order to utilize said signals

from said transducer for ranging and position assessment relative to outside and internal bodily structures.

17. Device according to claim 16, wherein said electronic circuit means are
5 utilized for ablation procedure steering and measurement, in particular steering of the moment of the release of the ablation energy.

18. Device according to claim 16 or 17, wherein said electronic circuits means
10 within an outside ultrasonic scanner connected to ablation energy generator are capable to localise an area in the ultrasonic echographic image only within which the release of ablation energy is required.

19. Device according to any of claims 16 to 18, wherein said piezoelectric
15 transducer assembly is connected to said electronic circuits means via the said lengthwise conductors whereby said electronic circuits means being capable of detecting incoming electrical signals received from said piezoelectric transducer assembly and representing ultrasonic pulses.

20. Device according to claim 16, wherein said piezoelectric transducer
20 assembly connected to said electronic circuits means via said lengthwise conductors whereby said electronic circuits means being capable of transmitting electrical signals to said transducer assembly for producing ultrasonic pulses.

21. Device according to claims 19 and 20, wherein said electronic circuits
25 means being capable of utilising said transmitted and received electrical signals for localisation of the position of said ablation electrode by means of A mode ranging.

22. Device according to claims 19 and 20, wherein said electronic circuits
30 means being capable of utilising said transmitted and received electrical signals for localisation of the position of said ablation electrode by means of M mode distance

measurement.

23. Device according to claims 19 and 20, wherein said electronic circuits means being capable of utilising said transmitted and received electrical signals for localisation of the position of said ablation electrode by means of introduction into B mode two dimensional image.

24. Device according to claims 19 and 20, wherein said electronic circuits means being capable of utilising said transmitted and received electrical signals for localisation of the position of said ablation electrode by means of Doppler velocity measurement.

25. Device according to any of claims 21 to 24, wherein said electronic circuits means being capable of utilising said transmitted and received electrical signals for localisation of the position of said ablation electrode by means of being capable of detection of coincidence of a predetermined position in either A, B, or M mode or velocity as measured by said circuits in conjunction with outside ultrasonic scanner with the operators request for delivery of the ablation energy being satisfied only in case of such a coincidence.

20

26. Device according to claim 25, wherein said electronic circuits means being capable to generate electrical signals for producing ultrasound pulses and to detect echoes (150, 151, 152) from heart structures by means of transmission and reception of electrical signals representing ultrasonic pulses.

25

27. Device according to claim 25, wherein said electronic circuits means being capable to measure the distance (153) between said transducer (62) and the heart tissue (61).

30

28. Device according to claim 25, wherein said electronic circuits means being

capable to detect the QRS complex of the electrocardiogram (154).

29. Device according to claim 27, wherein said electronic circuits means being capable to generate a proximity function (155), characterising the variation of said distance
5 (153) in time.

30. Device according to claim 29, wherein said electronic circuits means being capable of identifying crossing of said proximity function (155) over a preset and adjustable levels (156) within the measured distance (153).
10

31. Device according to claim 30, wherein said electronic circuits means being capable to modulate the power (157) of said ablation signal in such a way as to said power to appear only within a time interval between the time points (158, 159) wherein said proximity function (155) crosses the predetermined trigger level (156).
15

32. Device according to claim 31, wherein said power of said ablation signal is delivered to said ablation electrode only when said transducer assembly is in proximity to said heart tissue.

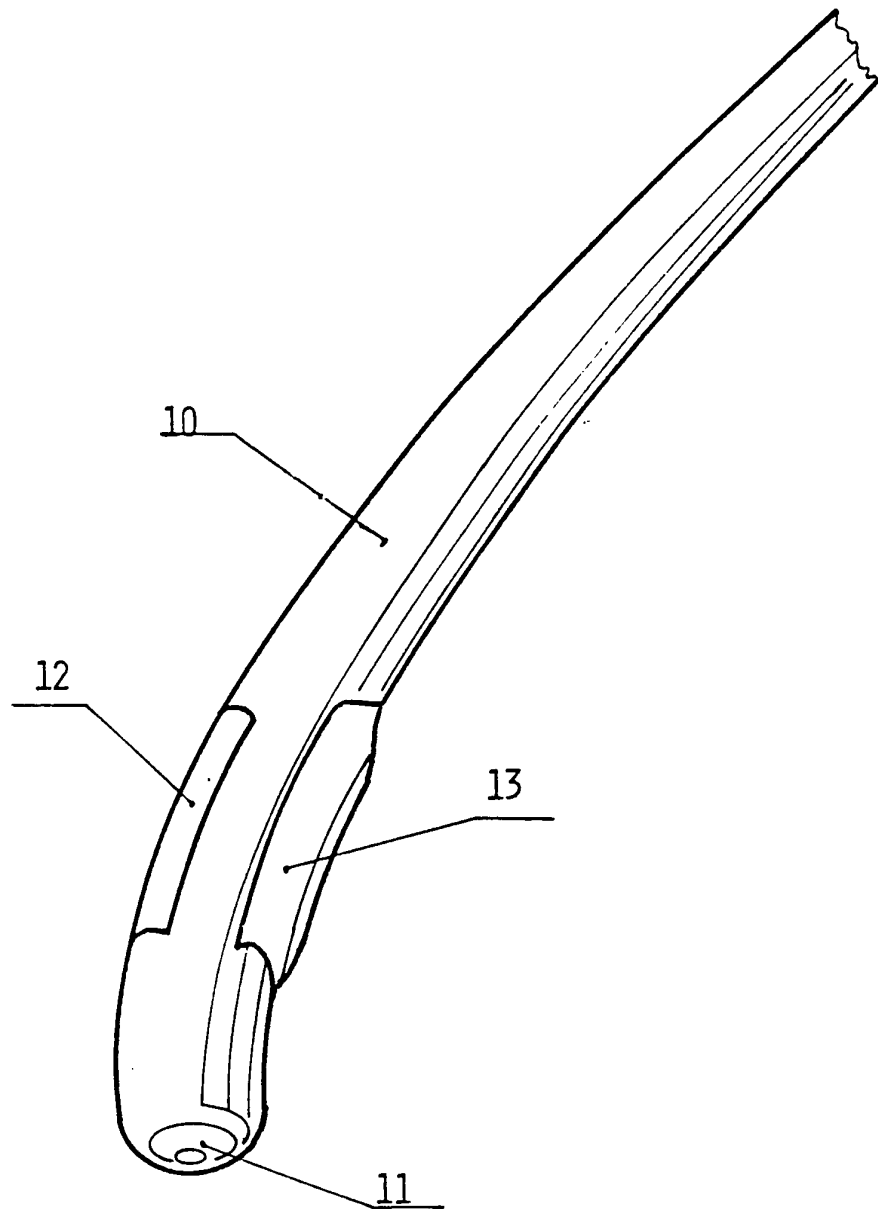

FIGURE 1

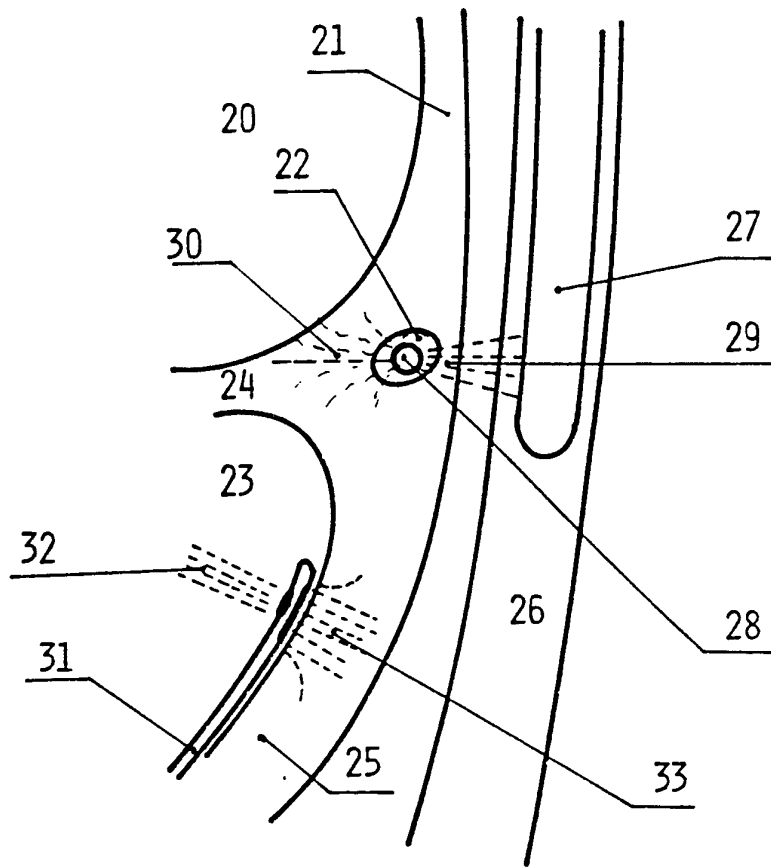

FIGURE 2

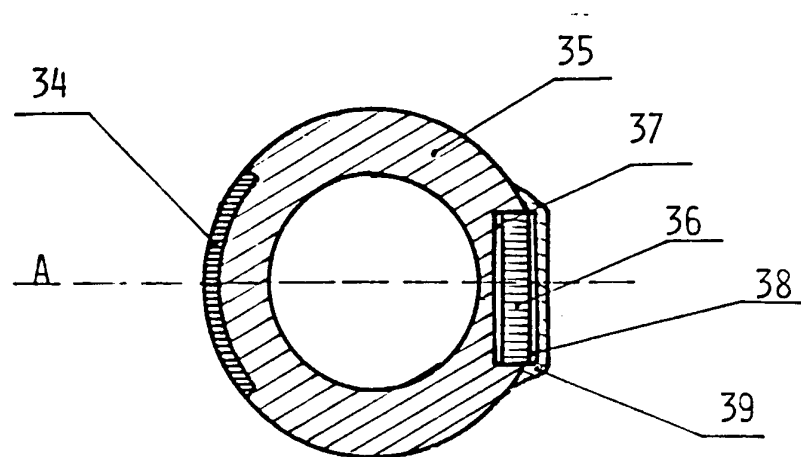

FIGURE 3

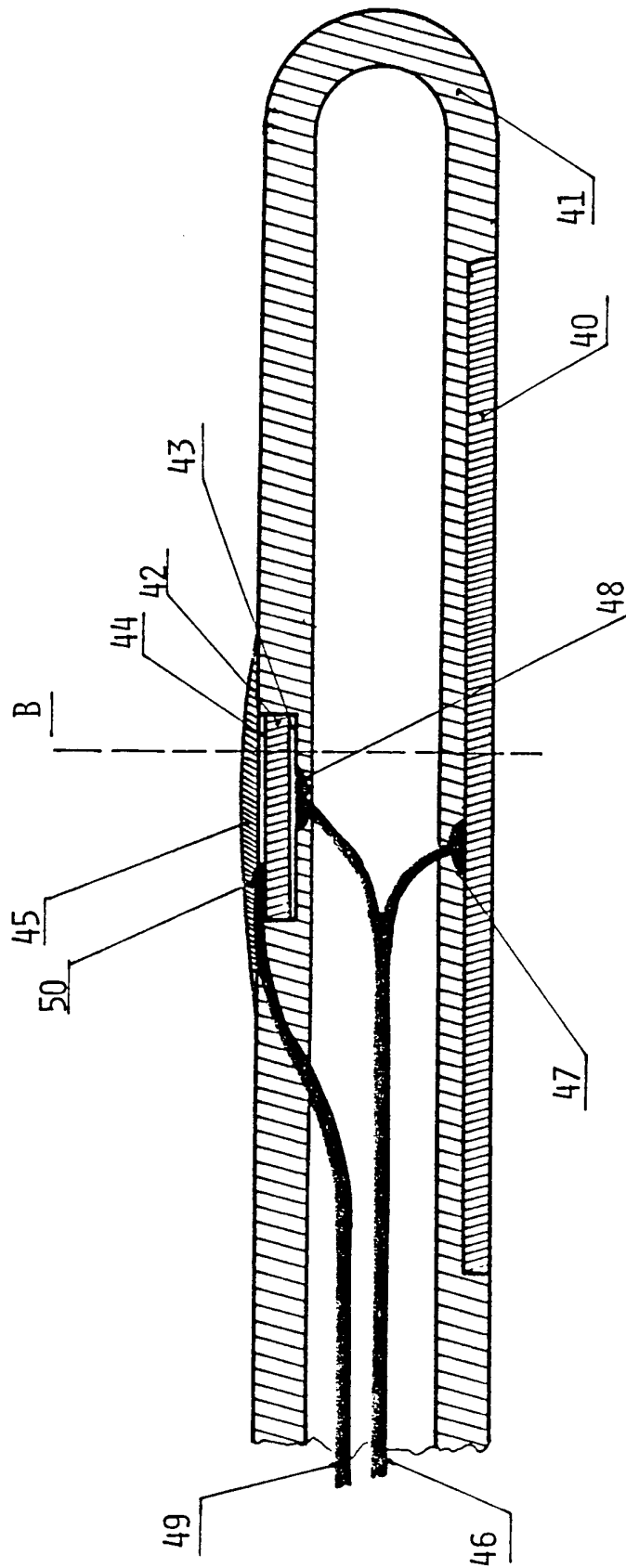

FIGURE 4

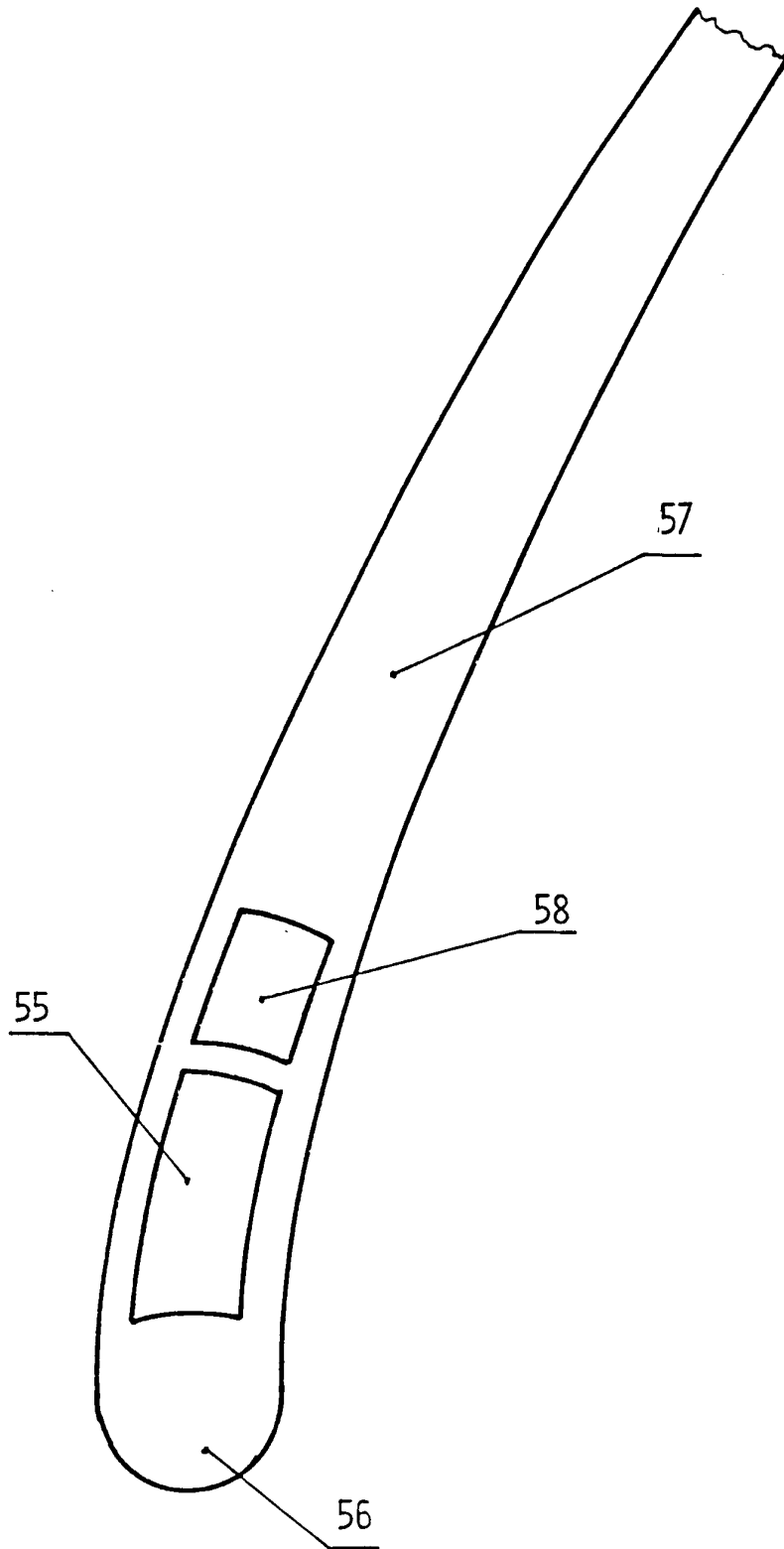

FIGURE 5

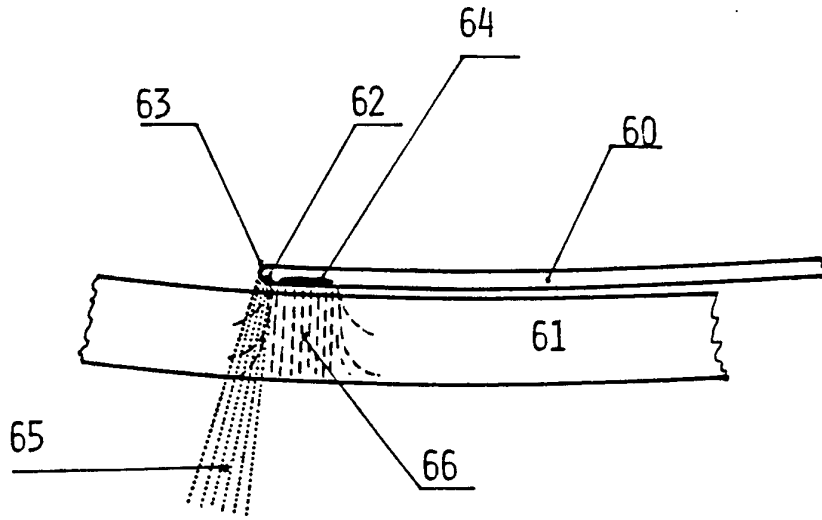

FIGURE 6

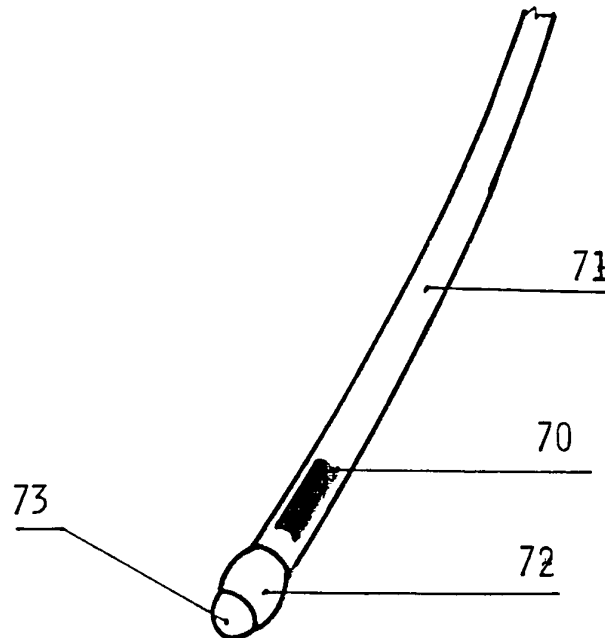

FIGURE 7

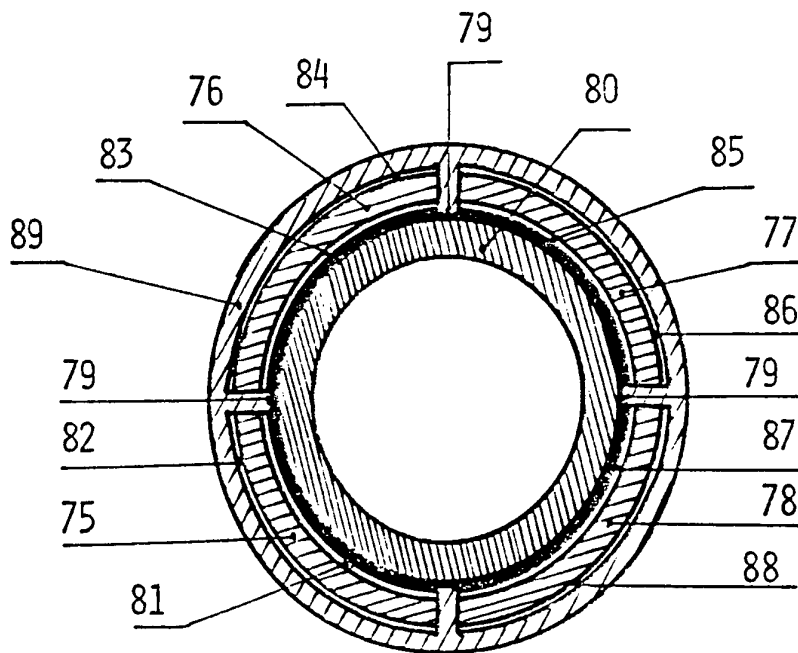

FIGURE 8

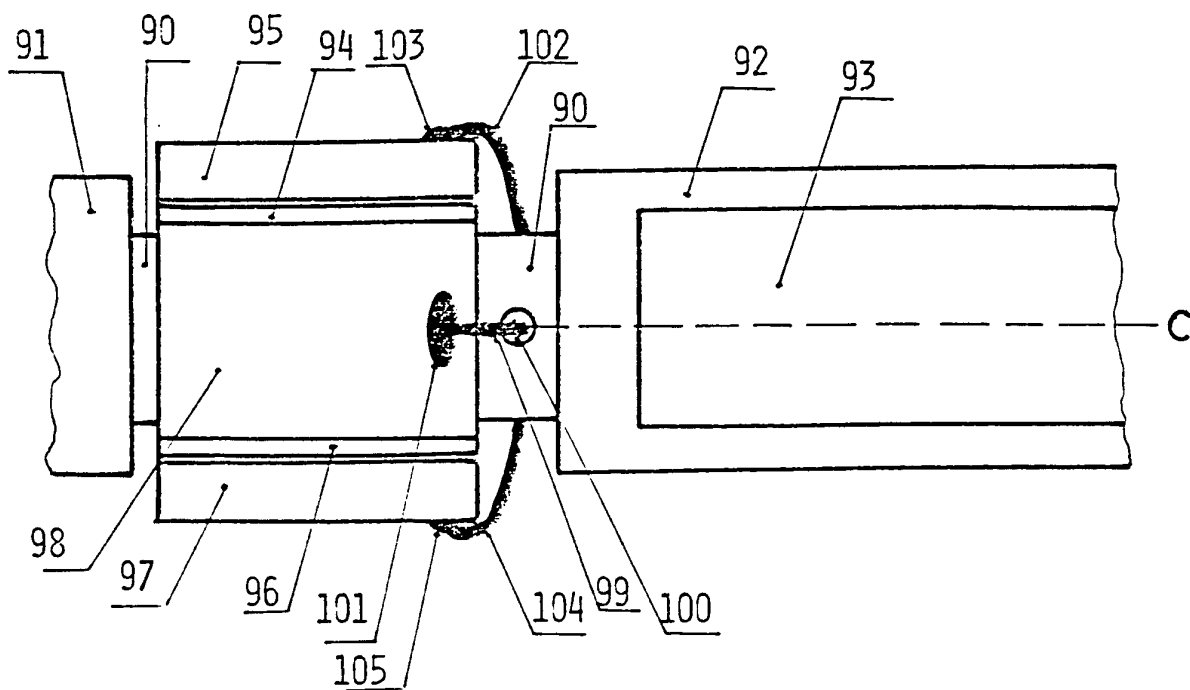

FIGURE 9

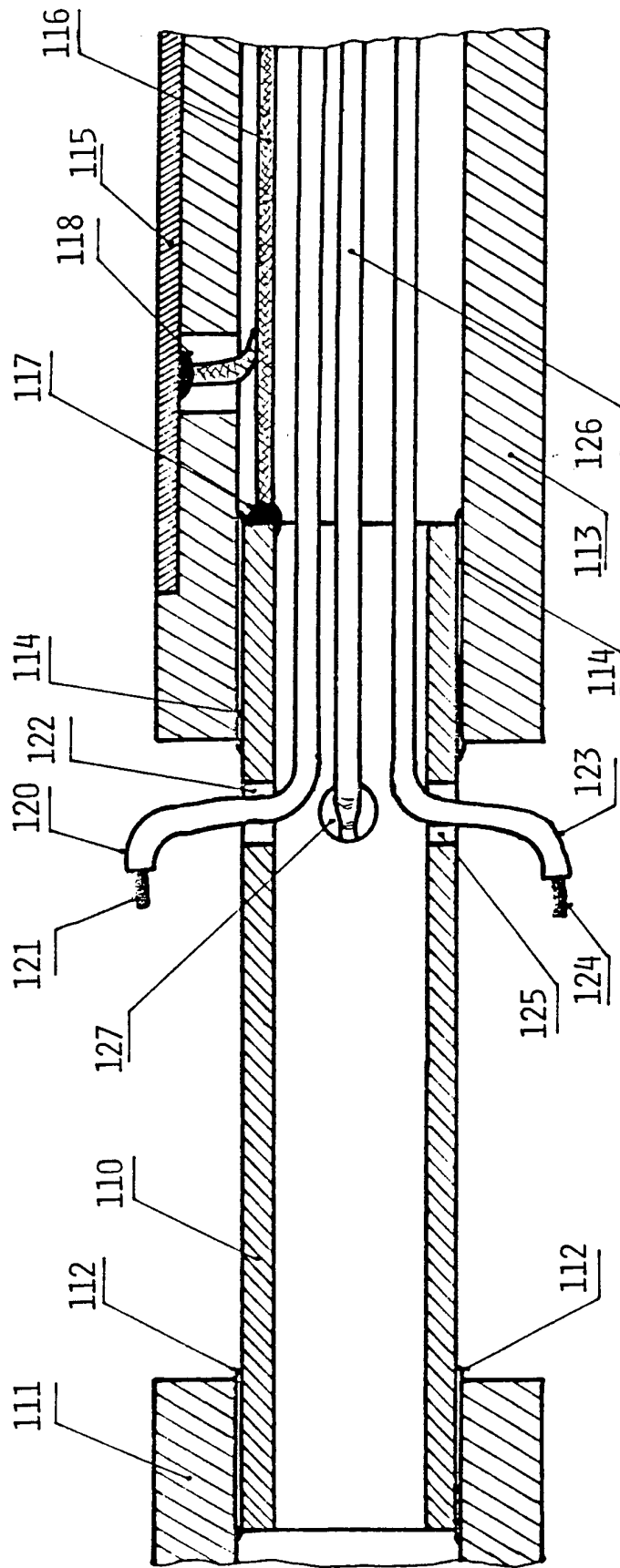

FIGURE 10

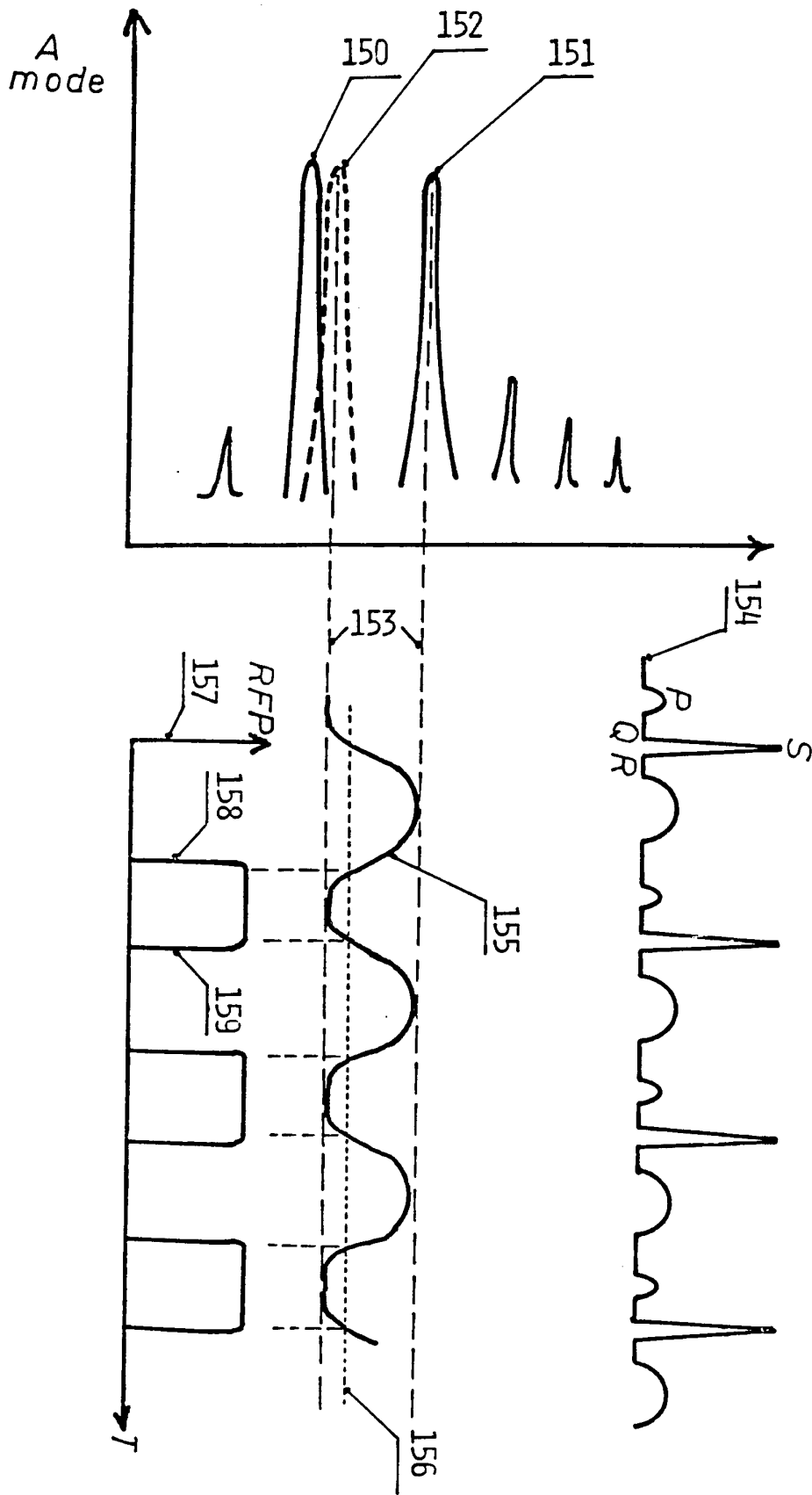

FIGURE 11

INTERNATIONAL SEARCH REPORT

Int. l. Application No

PCT/EP 94/04252

A. CLASSIFICATION OF SUBJECT MATTER
 IPC 6 A61B17/39 A61B8/12

According to International Patent Classification (IPC) or to both national classification and IPC

B. FIELDS SEARCHED

Minimum documentation searched (classification system followed by classification symbols)
 IPC 6 A61B

Documentation searched other than minimum documentation to the extent that such documents are included in the fields searched

Electronic data base consulted during the international search (name of data base and, where practical, search terms used)

C. DOCUMENTS CONSIDERED TO BE RELEVANT

Category °	Citation of document, with indication, where appropriate, of the relevant passages	Relevant to claim No.
X	US,A,4 936 281 (P STASZ) 26 June 1990 see column 3, line 34 - column 4, line 2 see column 4, line 26 - line 59 see column 5, line 43 - column 6, line 35 see figures 2-6 ---	1
X	WO,A,93 08738 (MAYO FOUNDATION) 13 May 1993 see page 7, line 2 - line 30 see page 16, line 3 - line 18 see page 17, line 25 - page 18, line 23 see figures 2,6,7 ---	1,5-7
A	GB,A,2 267 035 (ARIZONA BOARD OF REGENTS INC) 24 November 1993 see page 5, line 18 - page 6, line 16 see figures --- -/--	

Further documents are listed in the continuation of box C.

Patent family members are listed in annex.

° Special categories of cited documents :

- 'A' document defining the general state of the art which is not considered to be of particular relevance
- 'E' earlier document but published on or after the international filing date
- 'L' document which may throw doubts on priority claim(s) or which is cited to establish the publication date of another citation or other special reason (as specified)
- 'O' document referring to an oral disclosure, use, exhibition or other means
- 'P' document published prior to the international filing date but later than the priority date claimed

- 'T' later document published after the international filing date or priority date and not in conflict with the application but cited to understand the principle or theory underlying the invention
- 'X' document of particular relevance; the claimed invention cannot be considered novel or cannot be considered to involve an inventive step when the document is taken alone
- 'Y' document of particular relevance; the claimed invention cannot be considered to involve an inventive step when the document is combined with one or more other such documents, such combination being obvious to a person skilled in the art.
- '&' document member of the same patent family

Date of the actual completion of the international search

Date of mailing of the international search report

10 April 1995

21.04.95

Name and mailing address of the ISA

European Patent Office, P.B. 5818 Patentlaan 2
 NL - 2280 HV Rijswijk
 Tel. (+ 31-70) 340-2040, Tx. 31 651 epo nl,
 Fax (+ 31-70) 340-3016

Authorized officer

Vereecke, A

INTERNATIONAL SEARCH REPORT

Int. l. Application No
PCT/EP 94/04252

C.(Continuation) DOCUMENTS CONSIDERED TO BE RELEVANT		
Category *	Citation of document, with indication, where appropriate, of the relevant passages	Relevant to claim No.
A	FR,A,2 594 322 (J VAN CLEEF) 21 August 1987 ---	
A	WO,A,89 06934 (INTRA-SONIX INC.) 10 August 1989 -----	

1

INTERNATIONAL SEARCH REPORT
 information on patent family members

International Application No
PCT/EP 94/04252

Patent document cited in search report	Publication date	Patent family member(s)	Publication date
US-A-4936281	26-06-90	NONE	
WO-A-9308738	13-05-93	US-A- 5325860 CA-A- 2121353 EP-A- 0611292 US-A- 5345940	05-07-94 13-05-93 24-08-94 13-09-94
GB-A-2267035	24-11-93	US-A- 5295484 DE-A- 4316298 FR-A- 2696099 JP-A- 7000411	22-03-94 03-02-94 01-04-94 06-01-95
FR-A-2594322	21-08-87	NONE	
WO-A-8906934	10-08-89	US-A- 4862893 AU-A- 2928889 US-A- 5002058 US-A- 4977655	05-09-89 25-08-89 26-03-91 18-12-90