

677639

SPRUSON & FERGUSON

Australia

Patents Act 1990

NOTICE OF ENTITLEMENT

I, Gary L. Griswold, of Minnesota Mining and Manufacturing Company  
of 3M Center, P.O. Box 33427, Saint Paul, Minnesota, 55133-3427, United  
States of America

being authorised by the Applicant(s)/Nominated Person(s) in respect of  
Application No 61396/94 state the following:-

The Applicant(s)/Nominated Person(s) has/have entitlement from the actual  
inventor(s) as follows:-

Minnesota Mining and Manufacturing Company is the assignee of the actual  
inventor Johannes A. Ritter.

The Applicant(s)/Nominated Person(s) is/are entitled to rely on the  
application(s) listed in the Declaration under Article 8 of the PCT as follows:

Johannes A. Ritter made the basic application as the actual inventor of  
the invention and assigned his rights in the invention including the  
priority rights accruing from the said basic application to Minnesota  
Mining and Manufacturing Company.

The basic application(s) listed on the Declaration under Article 8 of the PCT  
is/are the first application(s) made in a Convention country in respect of the  
invention.

DATED this 24<sup>th</sup> day of September 1995

.....  
(Signature) Gary L. Griswold  
Chief Intellectual Property Counsel  
.....  
(Name & Title)

IRN: 310160

INSTR CODE: 53947

eab:2583T



AU9461396

**(12) PATENT ABRIDGMENT (11) Document No. AU-B-61396/94**  
**(19) AUSTRALIAN PATENT OFFICE (10) Acceptance No. 677639**

- (54) Title  
METHOD AND APPARATUS FOR APPLYING A COATING MATERIAL TO SHEETS
- International Patent Classification(s)  
(51)<sup>5</sup> C09J 007/02
- (21) Application No. : 61396/94 (22) Application Date : 15.02.94
- (87) ICT Publication Number : WO94/19419
- (30) Priority Data
- |             |           |              |
|-------------|-----------|--------------|
| (31) Number | (32) Date | (33) Country |
| 4305081     | 19.02.93  | DE GERMANY   |
- (43) Publication Date : 14.09.94
- (44) Publication Date of Accepted Application : 01.05.97
- (71) Applicant(s)  
MINNESOTA MINING AND MANUFACTURING COMPANY
- (72) Inventor(s)  
JOHANNES A. RITTER
- (74) Attorney or Agent  
SPRUSON & FERGUSON , GPO Box 3898, SYDNEY NSW 2001
- (56) Prior Art Documents  
GB 2166717
- (57) Claim

1. An apparatus for applying a coating material to a plurality of sheets as the sheets are conveyed past the apparatus, comprising:

a) means for overlapping a plurality of sheets, such that a first minor portion of each sheet overlies a portion of a first adjacent sheet and a second minor portion of each sheet underlies a portion of a second adjacent sheet wherein the first and second portions of each sheet are opposed portions of the sheet;

b) a coating station comprising (i) means for receiving coating material from a supply of such material, (ii) means for at least partially drying the coating material on the receiving means and (iii) means for transferring the coating material from the receiving means to at least a portion of a first major surface of the overlapped sheets as the sheets are conveyed past the coating station to form coated sheets; and

c) means for collecting the coated sheets.

15. An apparatus comprising:

a) a sheet dispensing station effective for dispensing a plurality of sheets in an overlapping configuration such that a first end of each sheet

(11) AU-B-61396/94  
(10) 677639

-2-

overlies a portion of a first adjacent sheet and a second end of each sheet underlies a portion of a second adjacent sheet so as to form a continuous array of overlapped sheets; and

- b) a first coating station effective for continuously applying an at least partially dried coating material to at least a portion of a first major surface of the overlapped sheets as the sheets move through the coating station.



AU9461396

INTE.

(51) International Patent Classification <sup>5</sup> :  
C09J 7/02

A1

(11) International Publication Number: WO 94/19419

(43) International Publication Date: 1 September 1994 (01.09.94)

(21) International Application Number: PCT/EP94/00421

(22) International Filing Date: 15 February 1994 (15.02.94)

(30) Priority Data:  
P 43 05 081.6 19 February 1993 (19.02.93) DE

(81) Designated States: AU, BB, BG, BR, BY, CA, CN, CZ, FI, HU, JP, KP, KR, KZ, LK, LV, MG, MN, MW, NO, NZ, PL, RO, RU, SD, SK, UA, UZ, VN, European patent (AT, BE, CH, DE, DK, ES, FR, GB, GR, IE, IT, LU, MC, NL, PT, SE), OAPI patent (BF, BJ, CF, CG, CI, CM, GA, GN, ML, MR, NE, SN, TD, TG).

Published  
With international search report.

~~(71)~~ (72) Applicant and Inventor: RITTER, Johannes, A. [DE/DE];  
Frankensteiner Strasse 44, D-64342 Seeheim-Jugenheim (DE).

(74) Agent: ZINNGREBE, Horst; Saalbaustrasse 11, D-64283 Darmstadt (DE).

677639

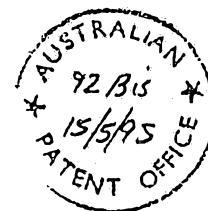

see  
folio

4  
(71) MINNESOTA MINING and  
MANUFACTURING COMPANY  
3M Center  
P.O. Box 33427  
Saint Paul, MN 55133-3427  
United States of America

(54) Title: METHOD AND APPARATUS FOR APPLYING A COATING MATERIAL TO SHEETS

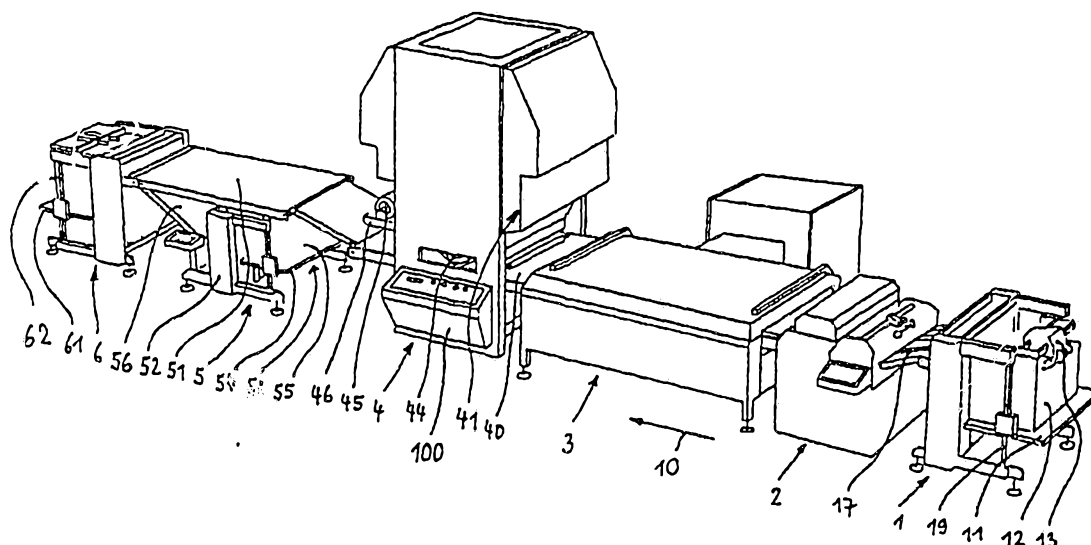

(57) Abstract

A method and apparatus for applying pressure sensitive adhesive to a substrate, in which the adhesive is deposited on a transfer surface, such as a circulating transfer belt, dried, and subsequently transferred to a plurality of overlapping sheets. The sheets are preferably coated with a primer or a low adhesion backsize, or both, prior to application of the adhesive.

METHOD AND APPARATUS  
FOR APPLYING A COATING MATERIAL TO SHEETS

TECHNICAL FIELD

The invention relates to a method and apparatus for the application of a coating material such as pressure sensitive adhesive, to individual sheets, such as sheets of paper.

BACKGROUND OF THE INVENTION

It is desirable in some fields to apply pressure sensitive adhesive to a paper substrate and several methods are known for performing this process. German patent application 36 06 199, for example, discloses a method and apparatus for applying pressure sensitive adhesive on a continuous web of paper. The web is coated with a primer, or adhesion promoter and dried in a first drying station. Next, an optional low adhesion backsize, or release layer, may be coated onto the opposite surface of the web and dried at a second drying station. Finally, a circulating intermediate carrier applies the pressure sensitive adhesive, which has been partially dried while on the intermediate carrier, over the primer layer. The paper web may then be collected and further processed as desired.

The various drying steps disclosed in the '199 patent (drying the primer layer, drying the low adhesion backsize layer, and drying the adhesive layer while on the intermediate carrier) remove moisture from the

aqueous primer, backsize and adhesive materials, to prevent the paper web from curling or wrinkling. However, the sequential application and drying of the primer and low adhesion backsize layers typically result in some curling of the paper web, which is undesirable. The curling problem would be more pronounced in the context of the application of a primer, low adhesion backsize, and adhesive to individual paper sheets rather than a paper web, because the web is typically in tension whereas the individual sheets are not. Thus, the method and apparatus of the '199 patent typically is not suitable for use with individual paper sheets.

It is an object of the present invention to substantially overcome or at least ameliorate prior art deficiencies.

#### SUMMARY OF THE INVENTION

Accordingly, in a first aspect, the present invention discloses an apparatus for applying a coating material to a plurality of sheets as the sheets are conveyed past the apparatus, comprising:

a) means for overlapping a plurality of sheets, such that a first minor portion of each sheet overlies a portion of a first adjacent sheet and a second minor portion of each sheet underlies a portion of a second adjacent sheet wherein the first and second portions of each sheet are opposed portions of the sheet;

b) a coating station comprising (i) means for receiving coating material from a supply of such material, (ii) means for at least partially drying the coating material on the receiving means and (iii) means for transferring the coating material from the receiving means to at least a portion of a first major surface of the overlapped sheets as the sheets are conveyed past the coating station to form coated sheets; and

c) means for collecting the coated sheets.

In a second aspect, the present invention discloses an apparatus comprising:

(a) a sheet dispensing station effective for dispensing a plurality of sheets in an overlapping configuration such that a first end of each sheet overlies a portion of



a first adjacent sheet and a second end of each sheet underlies a portion of a second adjacent sheet so as to form a continuous array of overlapped sheets; and

(b) a first coating station effective for continuously applying an at least partially dried coating material to at least a portion of a first major surface of the overlapped sheets as the sheets move through the coating station.

Preferably, the apparatus further comprises means for conveying the sheets, said conveying means comprising at least one vacuum belt connected to a source of low pressure for maintaining the position of the overlapping sheets on the belt.

10 BRIEF DESCRIPTION OF THE DRAWINGS

The present invention will be further explained with reference to the appended figures, wherein like structure is referred to by like numerals throughout the several views, and wherein:

Figure 1 is a schematic perspective view of an apparatus according to the present invention;

Figures 2 to 4 are a schematic side view of the stations of the apparatus of Figure 1;



Figure 5 is a top view of the apparatus according to Fig. 2;

Figure 6 is a perspective view of several overlapping sheets having a coating material applied thereto in accordance with the present invention; and

Figure 7 is a schematic diagram of a detail of the apparatus according to the invention.

#### DETAILED DESCRIPTION OF THE INVENTION

The present invention is preferably directed to the application of primer, low adhesion backsize, and pressure sensitive adhesive to a plurality of individual sheets of paper, and will be described primarily in that context. However, the present invention also has a broader applicability to the deposition of coating materials onto individual sheets of any type, and should be so understood.

In the illustrated embodiment, a preferred apparatus according to the present invention consists of six stations, arranged one after the other so that the sheets are conveyed through the respective stations, in a transporting direction indicated by the arrow 10 in Fig. 1. The stations include a sheet supplying station 1, a double coating station 2, a sheet conveying station with high frequency dryer 3, a coating station 4, a sheet inserting station 5 and a sheet stacking station 6, which are described in further detail below. These stations each have separate drive mechanisms, which are controlled by a central computer 100 to synchronize the respective drive mechanisms.

Sheet supplying station 1 has a table 11 for receiving a stack 12 of individual paper sheets. The sheets are preferably all of equal size and weight - 50cm by 70 cm (19.7 in by 27.6 in) and 80g/cm<sup>2</sup>, for example. A sheet lifter 13, mounted atop sheet supplying station 1, has a vacuum head 15 the suction orifice of which depends down to the uppermost sheet of stack 12. For removing the uppermost sheet from the stack 12 the suction orifice gets into contact with the rim area of that sheet which adjoins vertical outer surface 114 of the stack 12. When the head 15 rises, the outer end of the uppermost sheet is lifted. A stream of air is injected between the lifted portion of the uppermost sheet and the next sheet of stack 12 by a nozzle 110 mounted on the end of a flexible hose 112 which is coupled to a source of pressurized air through sheet lifter 13. By the injected airstream the uppermost sheet is lifted in its entirety from the stack 12 while being held at the suction head 15 by the suction force of the vacuum. Suction head 15 then is moved towards an entrance 14 of a conveyor 17 whose entrance has the form of a slot between two opposing rollers 16 and 18. The rollers 16, 18, extend transversely to the transport direction (arrow 10) and are in frictional contact with each other. One of the rollers, say lower roller 16, is driven to rotate about its axis by a not shown drive mechanism. Idle roller 18 follows the rotation of roller 16 and is supported in bearings such that it may yield upwardly for opening entrance 14 when a leading edge of a sheet is to be inserted.

When the leading edge of the lifted uppermost sheet is grasped by rollers 16, 18, it is driven through the entrance 14 along belt conveyor 17 with a speed that corresponds to the circumferential speed of roller 16.

Then the next sheet of stack 12 is lifted and fed into the entrance 14 between rollers 16 and 18. Such lifting and feeding is synchronized under control of computer 100 with the drive speed of the previous sheet such that the leading edge of the succeeding sheet enters entrance 14 when approximately one third of the length of the previous sheet is still outside entrance 14. Thus, all sheets of stack 12 are conveyed by conveyor 17 one after the other in an overlapped condition according to which approximately the trailing third of the length (taken in transport direction 10) of a sheet overlaps the leading section of the succeeding sheet.

When a number of sheets of the stack 12 one after the other are removed the height of the stack 12 will diminish and consequently the vacuum head will be lowered from sheet lifter to a greater extent. Sheet lifter 13 includes a control mechanism which detects an extent of lowering the suction head 15 beyond a given value. The control mechanism then activates a lift 116 to which table 11 is coupled, to run upwardly along opposing columns 19 for raising table 11. A sheet supplying station 1 as described above may be obtained by MABEG Maschinenbau GmbH, Offenbach, Germany, with the machine identification no. 41988.

According to another embodiment of the invention the

stack 12 and the related components and control may be arranged in a manner which allows an overlapping arrangement of the succeeding sheets in such a way that the leading section of each sheet overlies the trailing section of each preceding sheet.

The overlapped sheets that emerge from the sheet supplying station 1 are supplied by belt conveyor 17 to the entrance 24 of a registering portion 20 of double coating station 2. Within this registering portion, the transport speed of the overlapped sheets is raised to approximately threefold the speed of the sheets which are delivered by the belt conveyor 17, and the overlapping of succeeding sheets is reduced.

In detail, the registering portion 20 includes close to the entrance 24 a first pair of opposing rollers 21a, 21b, the axis of which extend parallel to those of rollers 16, 18. Roller 21a is arranged below the path 22 of the incoming overlapped sheets and is driven by a not shown drive mechanism controlled by the computer 100. Idle roller 21b is above path 22 and in frictional contact with roller 21a. Roller 21a is driven with the same speed as roller 16. Downstream of rollers 21a, 21b stop means 200 are provided in the path 22 which include a number of fingers which extend upwardly into path 22 and which are mounted on a common pivot axis below path 22. All fingers are aligned transversely to the transport direction 10. Upon a stop means inactivating command, all fingers may swung downwardly out of path 22 to allow the continuation of the run of

the sheets towards another pair of rollers 23a, 23b. In the absence of such command (or if an inverted command is received), all fingers rock upwardly into path 22 for stopping further progress of an incoming sheet by abutment of the leading edge thereof against the raised fingers. Roller 23a, being arranged below path 22 is driven approximately three times faster than roller 21a whereas idle roller 23b above path 22 frictionally contacting roller 23a follows the speed of roller 23a.

When the leading edge of the first incoming sheet is escaping rollers 21a, 21b it may pass the inactivated stop means 200 and will be grasped in between rollers 23a, 23b. That sheet then will be accelerated corresponding to the higher speed of rollers 23a, 23b. Stop means 200 is activated timely such that the succeeding sheet will abut stop means 200. Under control of computer 100, stop means 200 is inactivated (i.e. the fingers are swung down out of path 22) at a time the overlapping of the first sheet and the succeeding sheet has reduced to approximately 1.0 to 2.0 cm (0.4 to 0.8 in). After the leading edge of the succeeding sheet (together with the trailing edge of the first sheet) has been grasped between rollers 23a and 23b stop means 200 is again activated for stopping the next sheet. Again, the computer 100 commands inactivating the stop means 200 at a time the overlapping of second sheet and third sheet has reduced to approximately the aforementioned extent.

The overlapping for 1.0 to 2.0 cm of succeeding sheets

AMENDED SHEET



is maintained by strict control of the speeds of the drive mechanisms within the following portion of double coating station 2 and stations 3 and 4. The stop means 200 of the registering portion 20 also serves to properly align all incoming sheets before further processing thereof.

The accelerated overlapped sheets emerging the registering portion 20 are fed by assistance of guide rollers 28a, 28b into the coating portion 26 of double coating station 2 along the horizontally continuing path 22. Downstream of rollers 28a, 28b a first coating roller 25 is arranged above path 22 and a second roller 29 is arranged below path 22.

The first coating roller 25 cooperates with a metering roller 27. A trough 210 for receiving a first liquid is formed by a portion of the circumference of the metering roller 27 adjacent a slot 212 between the metering roller 27 and the first coating roller 25, a portion of the circumference of the first coating roller 25 adjacent slot 212 and two opposing side walls 214, 216 each of which is held in circumferential grooves 218, 220 and 222, 224, respectively of the metering roller 27 and the first coating roller 25. As can best be seen from fig. 3, those circumferential grooves 218, 220, 224, 226 are spaced apart along the axis of rollers 25, 27 and provided close to the opposing end surfaces thereof. The width of slot 212 between metering roller 27 and first coating roller 25 may be adjusted for instance by moving metering roller

27 towards to or away from first coating roller 25. Thereby the amount of liquid which finds its way out of trough 210 through slot 212 upon the upper surface of the sheets passing underneath first coating roller 25 may be controlled. A sheet stripper (not shown) is abutting the periphery of the first coating roller downstream the contact thereof with the sheets to prevent a sheet from wrapping around the first coating roller 25.

The first liquid, in an embodiment of the invention, is a primer, which is an aqueous solution of an organic binding agent and a cleaved mineral pigment. Specifically, that solution is obtained by mixing approximately 5% by volume of a binding agent (available under the trademark MOVIOL from Hoechst AG, Frankfurt/Main, Germany) and approximately 5% by volume of pigment (available under the trademark AEROSIL from Degussa AG, Frankfurt/Main, Germany) with approximately 90% by volume of water.

Thus, by rotating first coating roller 25 and metering roller 27 a continuous layer of primer is laid down on the web-like overlapped sheets across their width when they are passed underneath the first coating roller 25.

Above trough 210 a pump 228 is provided, the outlet pipe 230 of which opens above trough 210. The inlet port of pump 228 is connected to a suitable hose or pipe (not shown) to a source of the first liquid (primer). Moreover, trough 210 is provided with an overflow line 232 which returns to said source.

AMENDED SHEET



Below path 22 and vertically below first coating roller 25 a second coating roller 29 is provided which rotates with the same speed as the first coating roller 25 which corresponds to the accelerated transport speed of the overlapped sheets. A tank 240 for receiving a second liquid is held below second coating roller 29. A baling roller 260 is provided underneath and in contact and parallel to second coating roller 29 which, when tank 240 by not shown means is filled with that second liquid, dips into that liquid (fig. 2, 7). When second coating roller 29 and baling roller 260 are driven to rotate about their axes, liquid out of tank 240 is entrained with baling roller 260 and transferred to the periphery of second coating roller 29, which applies that liquid to the lower surface of the sheets passing between first and second coating rollers 25, 29. The circumferential surface of the second coating roller 29 in the direction of the axis of that roller is for about 1.0 to 2.0 cm (0.4 to 0.8 in) shorter than the width of the sheets to be coated to prevent the liquid coated upon the upper surface of the sheets from floating over the edges of the sheets and to mix with the liquid on the second coating roller 29. In the event the width of the sheets of another batch is smaller, the second coating roller 29 has to be replaced by a correspondingly shorter coating roller. By adjusting the pressure of the baling roller 260 against the second coating roller a desired thickness of the layer coated on the underside of the sheets by the second coating roller 29 may be obtained. A not shown sheet stripper is positioned to abut the second

coating roller 29 downstream of the contact area of the second coating roller 29 with the sheets to prevent the sheets from wrapping around the second coating roller.

The second liquid, in an embodiment of the invention, is a low adhesion backsize, which is an aqueous solution of an organic binding agent and an adhesive rejecting agent. Specifically, that solution may be made by mixing approximately 2% by volume of FINFIX BDA distributed by Nordmann and Rassmann, Hamburg, Germany, as binder, and approximately 10% by volume of TEGO-GLIDE 410 distributed by Tego-Chemie GmbH, Essen, Germany, as rejecting agent, and approximately 13% by volume of ethanol with approximately 75% by volume of water.

The above identified figures for percentages of ingredients may vary dependent from the characteristics of the used paper sheets.

Because the aqueous primer and the aqueous low adhesion backsize are applied to the sheets simultaneously and at the same position along the path 22 by first coating roller 25 and second coating roller 29 respectively, the forces that would otherwise lead to curling or cockling of the sheets substantially counteract against each other, so that the sheets retain their smooth, even form.

In a preferred embodiment, at least one, and preferably both of the coating rollers 25 and 29 are

interchangeable with coating rollers of different length suitable for use with more narrow and wider sheets, respectively.

The quantity of the aqueous solution of the primer deposited on the upper surface of the sheets may be controlled by the width of slot 212 such that approximately  $2\text{g/m}^2$  are deposited continuously upon the sheets. Similarly, the aqueous solution of low adhesion backsize deposited upon the undersurface of the sheets may range approximately to  $2\text{g/m}^2$  continuously along the total width of the sheets.

As a safety feature, a photo cell positioned ahead the coating rollers 25, 29 may monitor the presence of sheets along the path 22 within coating portion 26. In case the photo cell does not detect a sheet, the output signal thereof may cause lifting of the first coating roller 25 away from second coating roller 29, or in the alternative, may cause lowering second coating roller 29 with respect to first coating roller 25 in order to prevent contact of both rollers in the absence of sheets therebetween.

The overlapping arrangement of the sheets, and the reduced length of the low adhesion backsize roller both tend to prevent intermingling of the primer and the low adhesion backsize materials.

The sheet transport station 3 (Fig. 3) includes a frame 31, within which an endless vacuum belt 36 winds around

rollers 33, 35, 37, 39, which are transverse to the transport direction 10. At least one of said rollers is driven under control of the computer 100 such, that the endless vacuum belt 36 advances through the sheet transport station 3 with exactly the same speed as the speed of the sheets emerging from the double coating station 2. Thereby, the overlapped condition of 1.0 to 2.0 cm is maintained during passage of the sheets through station 3 above the portion of belt 36 between rollers 35 and 37. The overlapped sheets when advancing through station 3 upon belt 36 between rollers 35 and 37 are exposed to drying means for removing moisture from the primer solution and from the low adhesion backsize solution. In the illustrated embodiment, the drying means is shown as high frequency radiation source 38, which is powered by generator 30, located adjacent frame 31. In a preferred embodiment, one or more high frequency radiation sources are provided to dry the sheets. The frequency of the radiation emitted by the source 38 may be in the range of approximately 27 MHz. Importantly, the radiation does not interact with the material of the sheets, but deposits its energy within the primer layer and the low adhesion backsize layer to dry those layers. Stated differently, the sheets should preferably be radiation transparent with respect to the high frequency radiation, but the primer and low adhesion backsize should be radiation opaque with respect to that radiation.

For removing the moisture evaporated from the primer layer and the low adhesion backsize layer, the interior

AMENDED SHEET



of the frame may be ventilated by a continuous stream of dry air which may be introduced into the frame 31 above belt 36 and may escape from the frame through its bottom. In this way the water in the primer layer and low adhesion backsize layer is finally removed, so that the sheets are substantially dry as they exit the transport station 3 at roller 37.

The primer and low adhesion backsize layers should be dried at rates sufficient to prevent the sheets from curling. In a preferred embodiment the primer and low adhesion backsize are applied simultaneously, and are dried simultaneously at a uniform rate, so that the sheets do not curl or wrinkle. However, the primer and low adhesion backsize layers could be applied sequentially, or could be dried at differential rates, or both, as necessary to attenuate or prevent curling and wrinkling of the sheets.

Coating station 4 applies a pressure sensitive adhesive to the sheets on the same surface where the primer was applied by double coating station 2, by contacting the sheets with an adhesive coated transfer belt 42. In the illustrated embodiment, coating station 4 includes a table 40 upon which an endless vacuum transport belt 49 is advanced in transport direction 10. The speed of the belt 49 is controlled by computer 100 and is the same as the transport speed in station 3. Above table 40 a raised dome 41 is provided within which runs the endless transfer belt 42. Transfer belt 42 winds around roller 43a and application roller 45 and around rollers

43a, 43b, 43c, 43d, and transfer roller 44, at least one of which is driven. Transfer belt 42 may be made of, for example, silicon rubber.

Application roller 45 preferably comprises a peripheral cylindrical surface having a plurality of cavities, or intaglio cells, for receiving pressure sensitive adhesive from a supply of such adhesive contained within tube 46. The adhesive may be formulated according to US patent 4,495,318 to Howard or, in the alternative, according to US patent 3,691,140 to Silver, the contents of each of which are incorporated herein. Application roller 45 is interchangeable with other types of application rollers, so that pressure sensitive adhesive may be applied to transfer belt 42 in different patterns, at different coating weights, and at different line speeds. In the disclosed embodiment of the invention, the intaglio cells may extend completely around the periphery of application roller 45 in spaced rings for obtaining spaced and lengthwise adhesive strips 58 on sheets 56 (Fig. 6). Application roller 45 preferably rotates such that the peripheral surface of the application roller moves in the opposite direction of transfer belt 42, as shown in fig. 4. A doctor blade may also be provided between tube 46 and transfer belt 42, to doctor off excess adhesive from the application roller so that only the adhesive within the intaglio cells is applied to the transfer belt 42.

Transfer belt 42 is entrained over rollers 43a, 43b,

43c and 43d, and the adhesive carried on the transfer belt is exposed to a first heating device 47, and subsequently to a second heating device 48. Heating devices 47 and 48 are preferably infrared heating devices, although other heating devices, such as high frequency heaters, are also contemplated. Also, more or less heating devices and those shown may be provided. When a section of transfer belt 42 that has been coated with adhesive has passed first and second heating devices 47 and 48, the adhesive on transfer belt 42 is substantially dry, and can be applied to the overlapped sheets by transfer roller 44. One or more optional temperature feedback sensors (not shown) may be positioned adjacent the heating devices, to measure the temperature of the adhesive layer and to adjust the amount of heat applied by the heating devices to dry the adhesive sufficiently.

The adhesive is transferred from the transfer belt 42 to the overlapping sheets at an application interface between transfer roller 44 and opposed roller 44a. Opposed roller 44a supports the sheets against the transfer roller 44, and after the adhesive has been applied to the sheets, the coated sheets are conveyed toward sheet inserting station 5 by vacuum belt 49 for further processing.

The pattern of adhesive disposed on the sheets depends on the pattern of adhesive applied by application roller 45 to transfer belt 42. In one embodiment, application roller 45 includes a plurality of intaglio

cells arranged in two bands spaced along the application roller. Thus, two continuous bands of adhesive are applied to the transfer belt 42, and subsequently to the overlapped sheets. The sheets so produced are illustrated in figure 6, wherein sheets 56 include spaced bands of adhesive 58. After sheets 56 have been stacked in the manner described below with respect to stacking station 6 to form master pads, the master pads may be guillotined into individual pads of repositionable notes. The location, coating weight, and other characteristics of the pressure sensitive adhesive layer applied to the sheets may be changed by changing the application roller, or by altering the operating parameters such as line speed, adhesive properties, and the like.

The overlapped sheets that emerge from coating station 4 on vacuum belt 49 are conveyed to sheet inserting station 5, which draws the sheets with a slightly higher speed. Thereby, the overlapping of succeeding sheets is removed so that a leading edge of a sheet follows a trailing edge of the preceding sheet. In station 5 a sheet may be injected between coated sheets at desired intervalls. The injected sheets preferably are different from the coated sheets (a different color or material, for example), although they may instead be similar to the coated sheets. Preferably, the injected sheets are uncoated, and form the bottom sheet of a master pad of repositionable notes.

Sheet inserting station 5 contains a substantially

horizontal transport floor 51 having transport belts (not shown). Frame 52 supports transport floor 51, below which is a sheet stacker 53. Sheet stacker 53 has a stack 55 of uncoated sheets that are deposited on plate 54. Further, the sheet inserting station may include a counter (not shown) that counts the sheets delivered from coating station 4. After a predetermined number of coating sheets are counted, the counter signals the sheet inserting station 5 to inject an uncoated sheet from stack 55 between the coated sheets, via a ramp rising from stack 55 to transport floor 51.

The sheet inserting station 5 is coupled to the exit side with a sheet stacking station 6, in which the sheets received from the sheet inserting station 5 are collected and are aligned with each other. The aligned, coated sheets are then deposited in the form of stack 62 on plate 61. The stacks of sheets may then be compressed to form master pads of repositionable notes, removed, and guillotined as known in the art to form individual pads of repositionable notes. Depending on the adhesive formulation coated onto the sheets, it may be desirable to allow the coated sheets to age (12 hours, for example) prior to guillotining, to allow the adhesion strength to increase as the adhesive dries more completely.

The above described machine may be run such that an output of approximately 4000 coated sheets per hour is obtained.

The advantages of the described apparatus are numerous. For example, the coating of supplied sheets of paper or similar material with pressure sensitive adhesive stripes is achieved in such a way that the sheets typically do not show any waviness, curling or other deviation from flatness. Also, the inventive apparatus permits sheets of various sizes to be coated, limited only by the width of the transport mechanism that conveys the sheets through the apparatus. Thus, aside from the installation of suitable coating and transfer rollers, no other changes in machine parts are needed when the size of the sheets which are to be coated is changed.

Other benefits include the ability to provide sheets having different printed messages, different cutters, different materials (recycled or virgin paper, for example), or different textures, for example, within a single batch or stack of sheets. For example, a calendar (having different printed information on each sheet) could be easily produced by the method of the present invention if the stack of sheets were organized in the proper order. Another advantage is that the coating materials used with the present invention are preferably water based, and thus potentially harmful organic solvents may be eliminated from the coating process.

The present invention has now been described with reference to several embodiments thereof. It will be apparent to those skilled in the art that many changes

can be made in the embodiments described without the departing from the scope of the invention. Thus, the scope of the present invention should not be limited to the structures described herein, but rather by the structures by the language of the claims, and the equivalents of those structures.

The claims defining the invention are as follows:

1. An apparatus for applying a coating material to a plurality of sheets as the sheets are conveyed past the apparatus, comprising:

a) means for overlapping a plurality of sheets, such that a first minor  
5 portion of each sheet overlies a portion of a first adjacent sheet and a second minor portion of each sheet underlies a portion of a second adjacent sheet wherein the first and second portions of each sheet are opposed portions of the sheet;

b) a coating station comprising (i) means for receiving coating material from a supply of such material, (ii) means for at least partially drying the coating  
10 material on the receiving means and (iii) means for transferring the coating material from the receiving means to at least a portion of a first major surface of the overlapped sheets as the sheets are conveyed past the coating station to form coated sheets; and

c) means for collecting the coated sheets.

15 2. The apparatus of claim 1, wherein the coating station is a station effective for coating the sheets with a pressure-sensitive adhesive.

3. The apparatus of claim 1, wherein the apparatus is effective for applying a coating material to paper sheets.

4. The apparatus of claim 1, wherein the coating material receiving and  
20 applying means comprises an endless transfer belt that receives the coating material and applies the coating material to the overlapping sheets.



5. The apparatus of claim 1, further comprising a coating material application means comprising a rotating cylinder that receives the coating material from a supply from such material and applies the coating material to the receiving means.

6. The apparatus of claim 1, wherein the drying means comprises a high frequency dryer.

7. The apparatus of claim 1, wherein the apparatus further comprises a second coating station between the overlapping means and the first coating station for applying a primer layer to the first major surface of each sheet, and a low adhesion backsize to a second major surface of each sheet, prior to application of the coating material.

8. The apparatus of claim 7, wherein the second coating station consists of first and second opposed rollers between which the sheets are conveyed, whereby the first roller applies the primer to the first major surface of the sheet, and the second roller applies the low adhesion backsize to the second major surface of the sheet.

9. The apparatus of claim 7, wherein said second coating station further comprises means for drying the primer and means for drying the low adhesion backsize.

10. The apparatus of claim 1, wherein said coating station further comprises means for continuously applying at least one longitudinally extending area of coating material to and across the overlapping sheets.



11. The apparatus of claim 1, wherein the coating material is applied to the receiving and applying means by a cylindrical gravure roller.

12. The apparatus of claim 1, wherein the collecting means comprises a stacking station for aligning and stacking the coated sheets with respect to each other.

13. The apparatus of claim 1, wherein the apparatus further comprises a sheet injection station positioned between the coating station and the collection means for periodically injecting a sheet between the coated sheets prior to collection of the sheets by the collecting means.

14. The apparatus of claim 1, wherein the apparatus further comprises means for conveying the overlapped sheets past the coating station and into the collecting means, said conveying means comprising at least one vacuum belt connected to a source of low pressure for removing the overlapped sheets and coating material from the transferring means.

15. An apparatus comprising:

- a) a sheet dispensing station effective for dispensing a plurality of sheets in an overlapping configuration such that a first end of each sheet overlies a portion of a first adjacent sheet and a second end of each sheet underlies a portion of a second adjacent sheet so as to form a continuous array of overlapped sheets; and
- b) a first coating station effective for continuously applying an at least partially dried coating material to at least a portion of a first major surface of the overlapped sheets as the sheets move through the coating station.



16. The apparatus of claim 15, wherein the first coating station is a station effective for coating the sheets with a pressure-sensitive adhesive.

17. The apparatus of claim 15, wherein the apparatus is effective for applying a coating material to paper sheets.

5 18. The apparatus of claim 15, wherein the coating station comprises (i) an endless transfer belt, (ii) an applicator which applies coating material to the transfer belt, (iii) a first mechanism for drying the coating material on the transfer belt, and (iv) a means for transferring the at least partially dried coating material from the transfer belt to the sheets.

10 19. The apparatus of claim 15, wherein the apparatus further comprises a second coating station between the sheet dispensing station and the first coating station for applying a primer layer to the first major surface of each sheet, an a low adhesion backsize to a second major surface of each sheet, prior to application of the coating material.

15 20. The apparatus of claim 19, wherein the apparatus further comprises a mechanism for drying the primer and low adhesion backsize applied to the sheets which is positioned between the second coating station and the first coating station.

20 21. An apparatus for applying a coating material to a plurality of sheets as the sheets are conveyed past the apparatus substantially as hereinbefore described with reference to the accompanying drawings.

DATED this Twentieth Day of January 1997

**Minnesota Mining and Manufacturing Company**

Patent Attorneys for the Applicant

**SPRUSON & FERGUSON**



SUBSTITUTE SHEET (RULE 26)

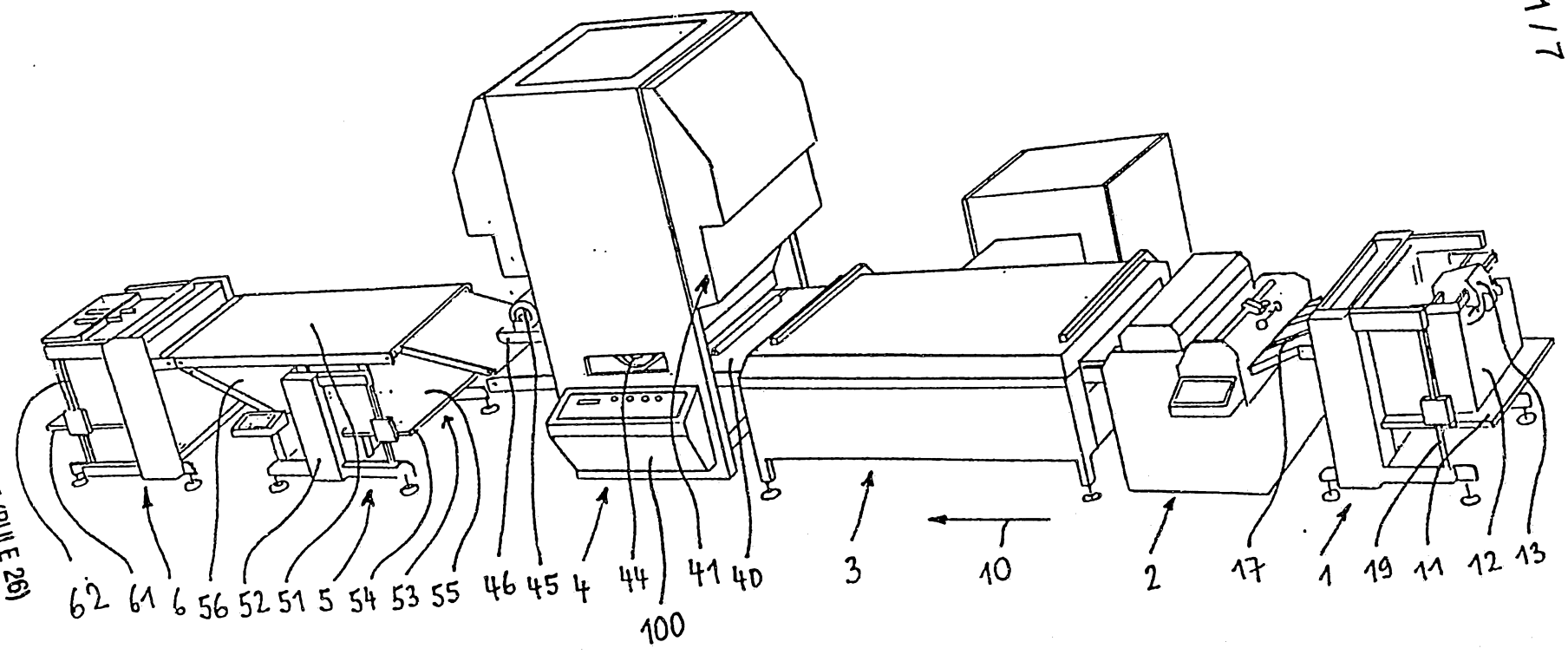
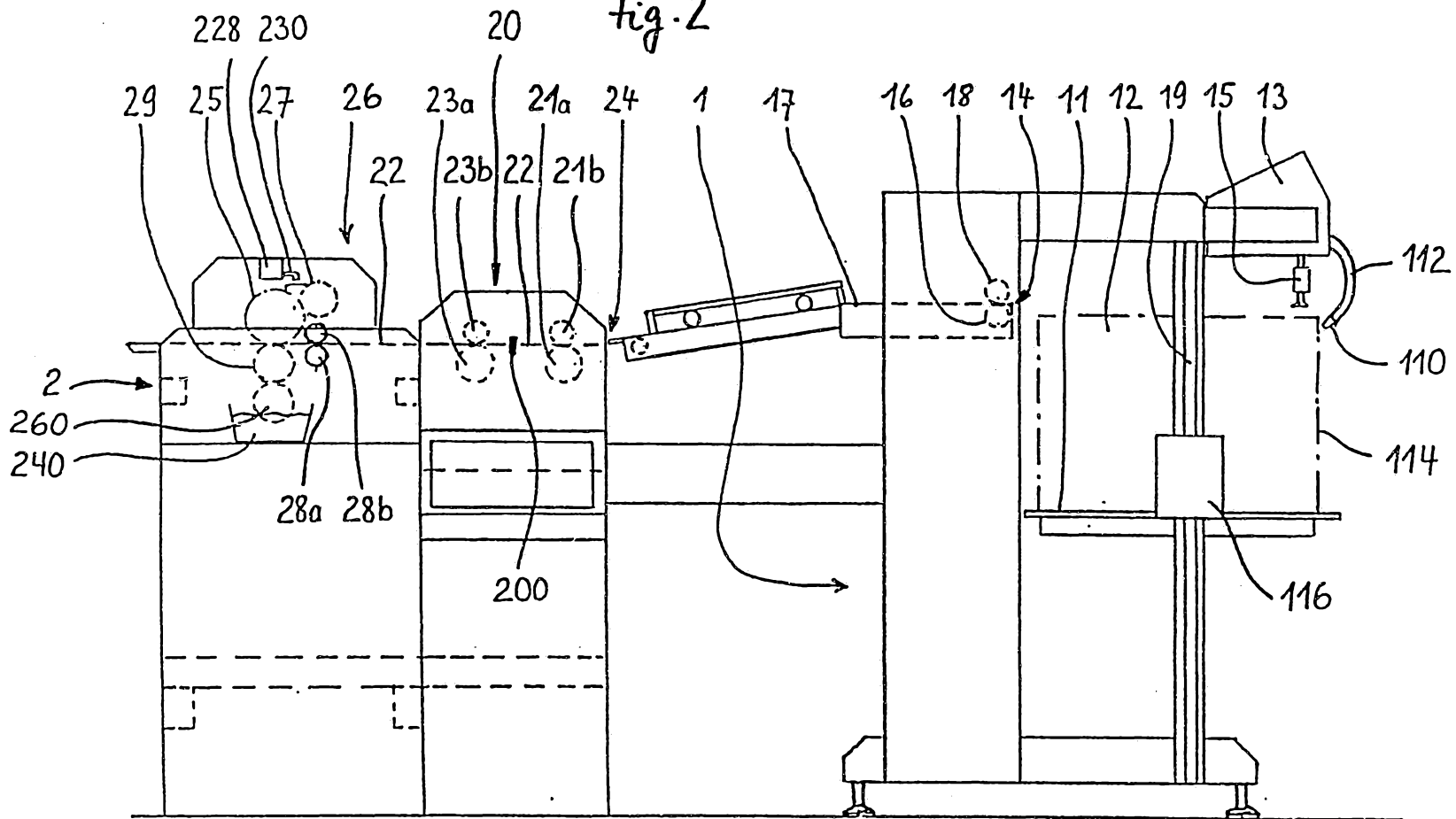
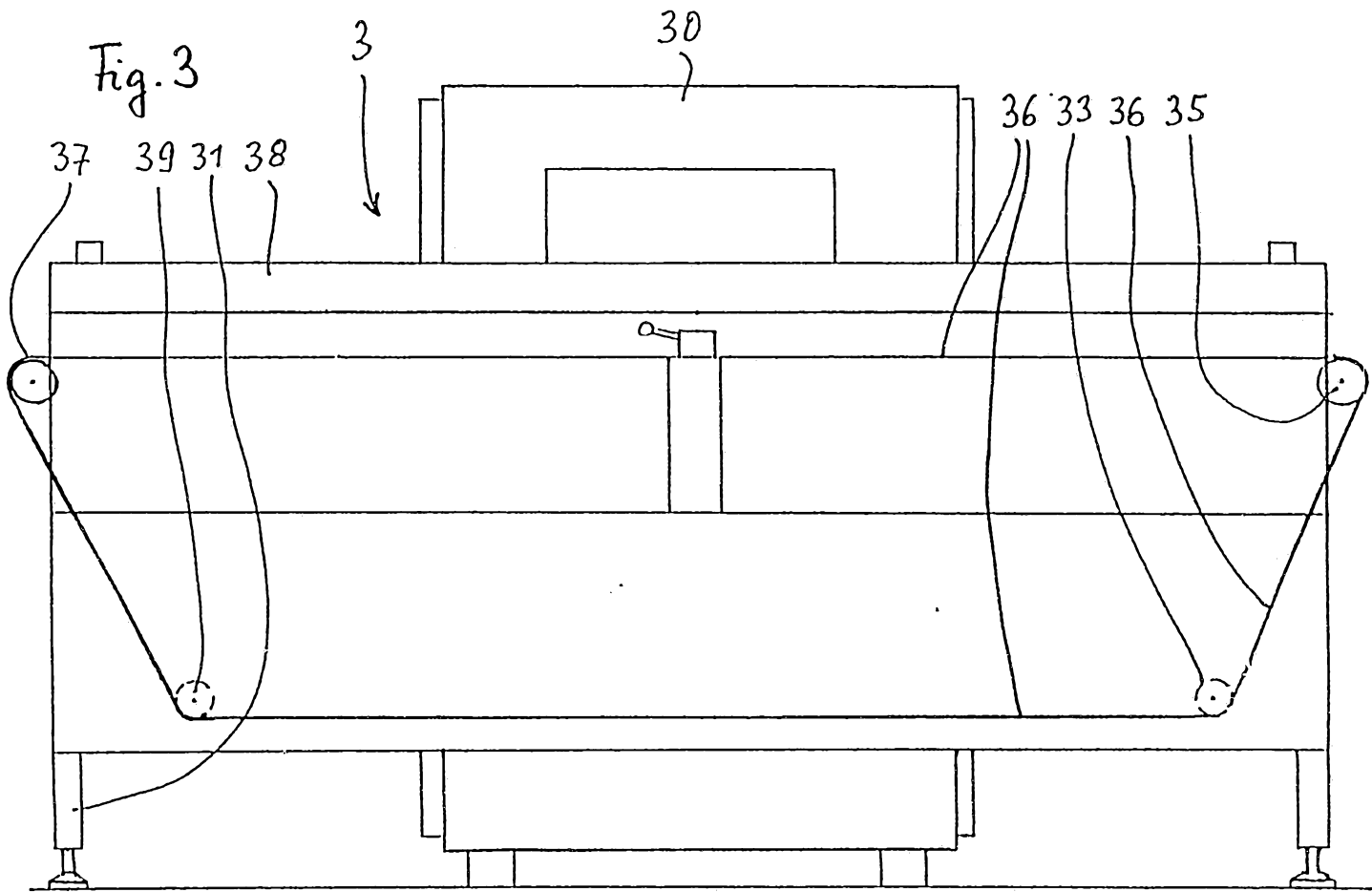

Fig. 1

Fig. 2



SUBSTITUTE SHEET (RULE 26)



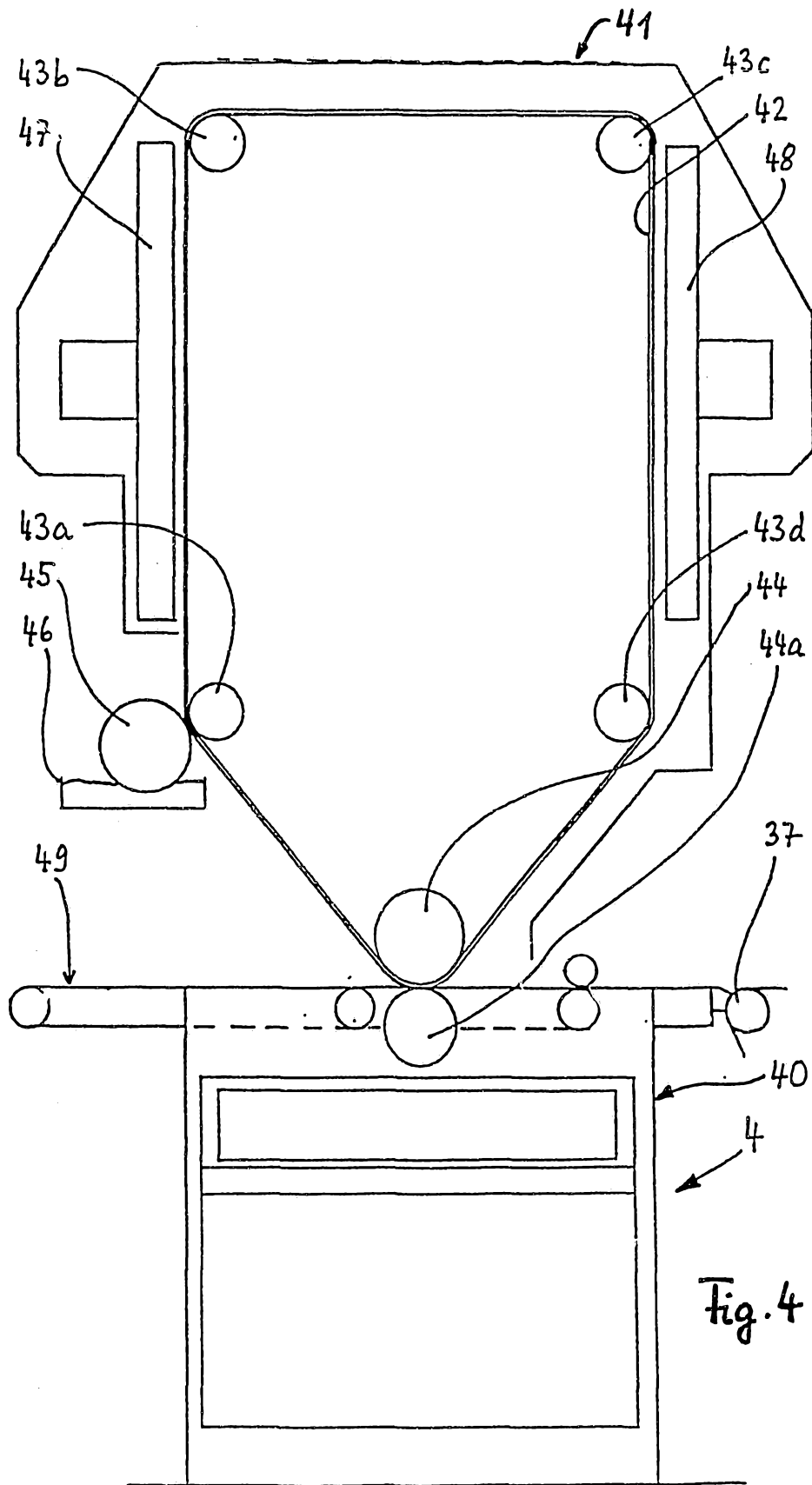
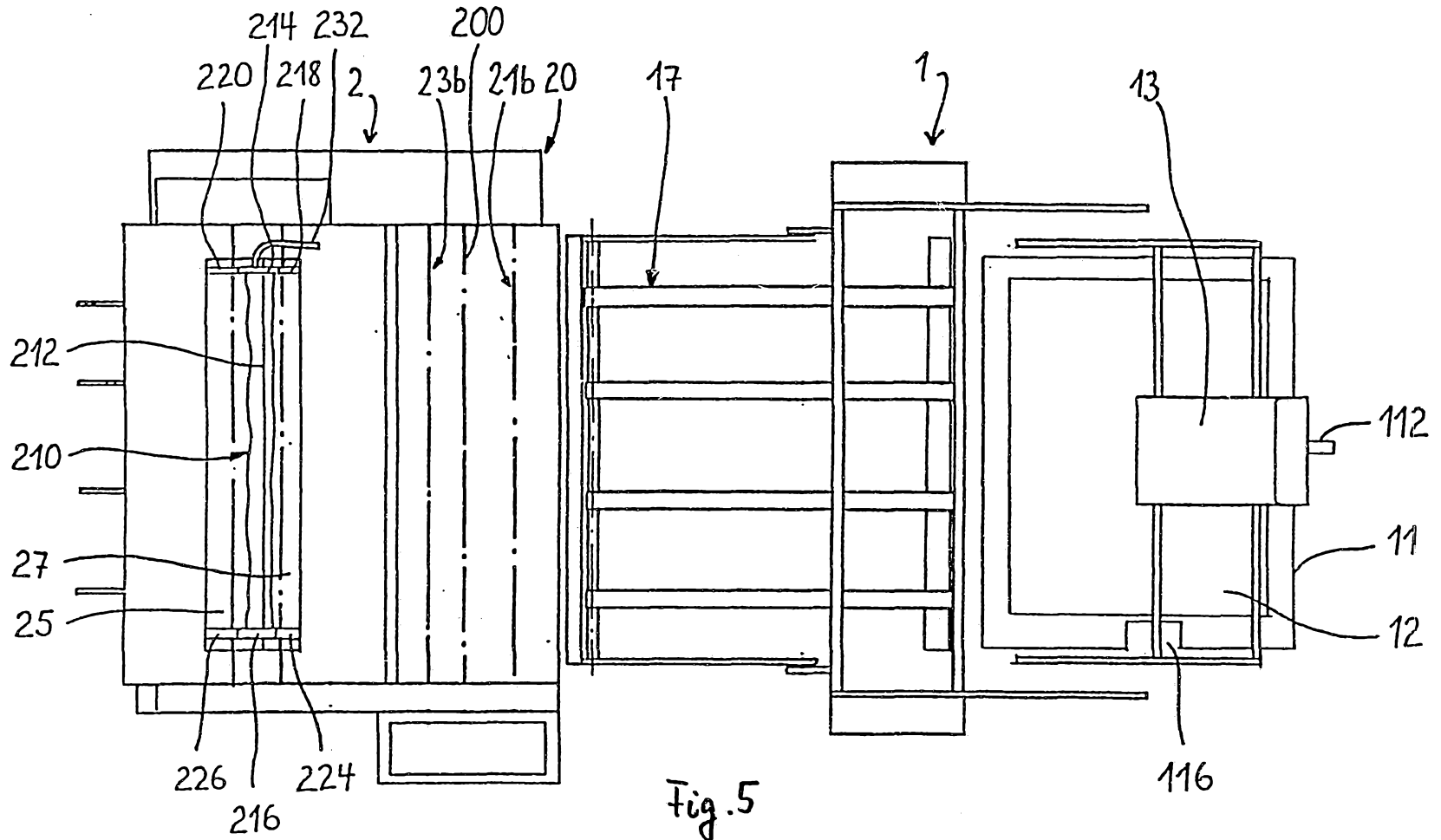

Fig. 4

SUBSTITUTE SHEET (RULE 26)



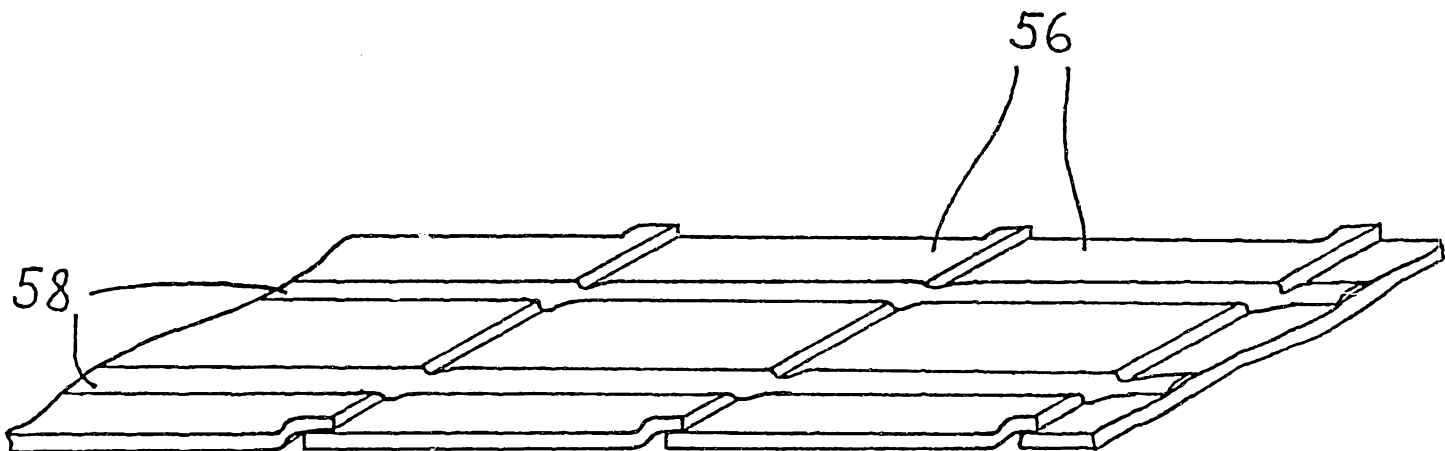
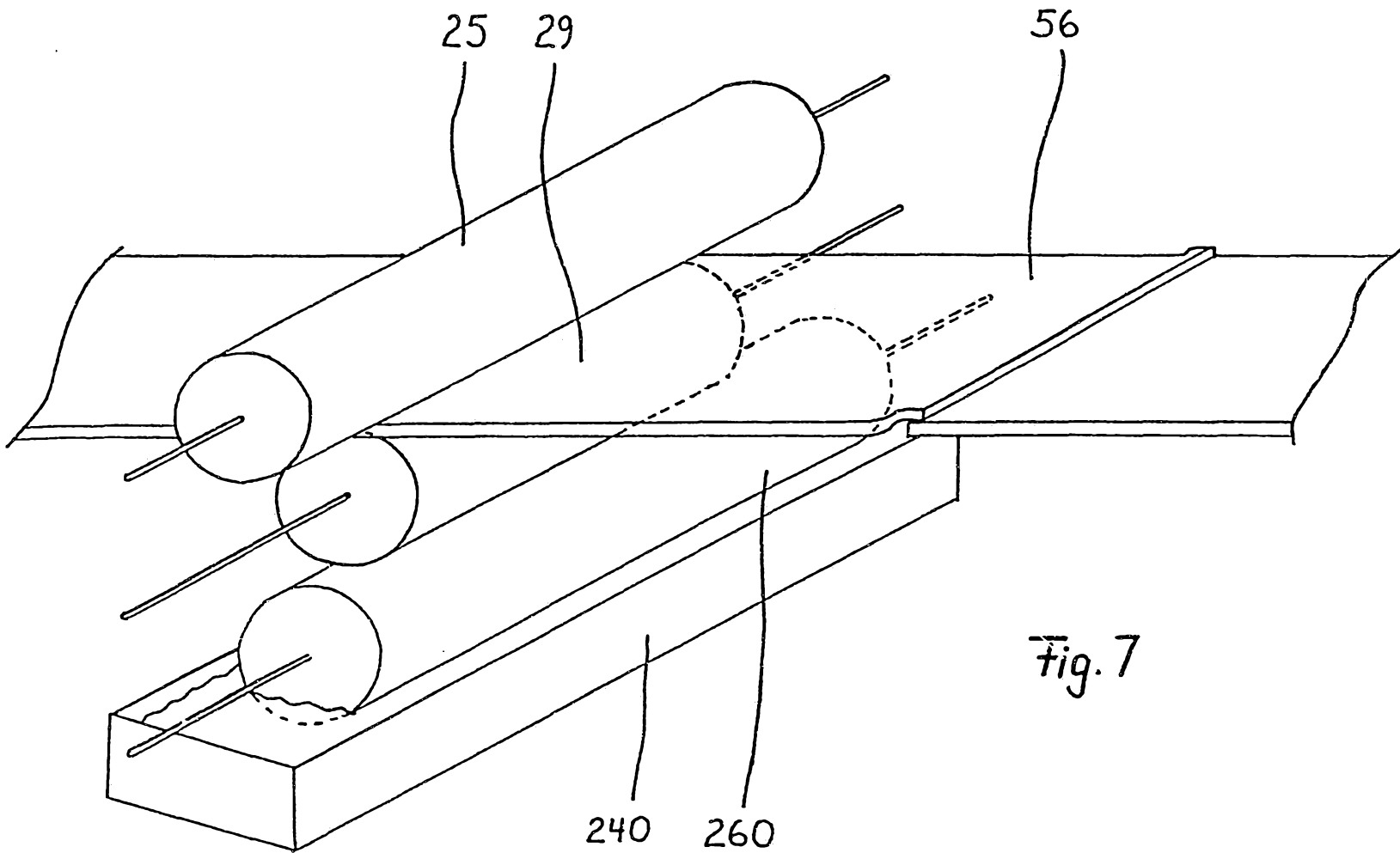

Fig. 6



SUBSTITUTE SHEET (RULE 26)

INTERNATIONAL SEARCH REPORT

International Application No

PCT/EP 94/00421

A. CLASSIFICATION OF SUBJECT MATTER  
IPC 5 C09J7/02

According to International Patent Classification (IPC) or to both national classification and IPC

B. FIELDS SEARCHED

Minimum documentation searched (classification system followed by classification symbols)  
IPC 5 C09J

Documentation searched other than minimum documentation to the extent that such documents are included in the fields searched

Electronic data base consulted during the international search (name of data base and, where practical, search terms used)

C. DOCUMENTS CONSIDERED TO BE RELEVANT

Category *	Citation of document, with indication, where appropriate, of the relevant passages	Relevant to claim No.
A	DE,A,36 06 199 (PAGENDARM) 27 August 1987 see page 2, line 26 - page 5, line 55; claims	1
A	GB,A,2 166 717 (RODWELL-HTR) 14 May 1986 see claims; figures 1,2	1

Further documents are listed in the continuation of box C.

Patent family members are listed in annex.

\* Special categories of cited documents :

- \*A\* document defining the general state of the art which is not considered to be of particular relevance
- \*E\* earlier document but published on or after the international filing date
- \*L\* document which may throw doubts on priority claim(s) or which is cited to establish the publication date of another citation or other special reason (as specified)
- \*O\* document referring to an oral disclosure, use, exhibition or other means
- \*P\* document published prior to the international filing date but later than the priority date claimed

- \*T\* later document published after the international filing date or priority date and not in conflict with the application but cited to understand the principle or theory underlying the invention
- \*X\* document of particular relevance; the claimed invention cannot be considered novel or cannot be considered to involve an inventive step when the document is taken alone
- \*Y\* document of particular relevance; the claimed invention cannot be considered to involve an inventive step when the document is combined with one or more other such documents, such combination being obvious to a person skilled in the art.
- \*&\* document member of the same patent family

Date of the actual completion of the international search

3 June 1994

Date of mailing of the international search report

17. 06. 94

Name and mailing address of the ISA  
European Patent Office, P.B. 5818 Patentlaan 2  
NL - 2280 HV Rijswijk  
Tel. (+31-70) 340-2040, Tx. 31 651 epo nl,  
Fax: (+31-70) 340-3016

Authorized officer

Bourgonje, A

# INTERNATIONAL SEARCH REPORT

Information on patent family members

Int. Patent Application No

PCT/EP 94/00421

Patent document cited in search report	Publication date	Patent family member(s)	Publication date
DE-A-3606199	27-08-87	WO-A- 8705315 EP-A- 0258353 JP-T- 63502514	11-09-87 09-03-88 22-03-88
GB-A-2166717	14-05-86	NONE	