

No. 760,085.

PATENTED MAY 17, 1904.

J. W. STOCKETT.
BREECH MECHANISM FOR ORDNANCE.

APPLICATION FILED FEB. 1, 1902.

NO MODEL.

2 SHEETS—SHEET 1.

Fig. 1.

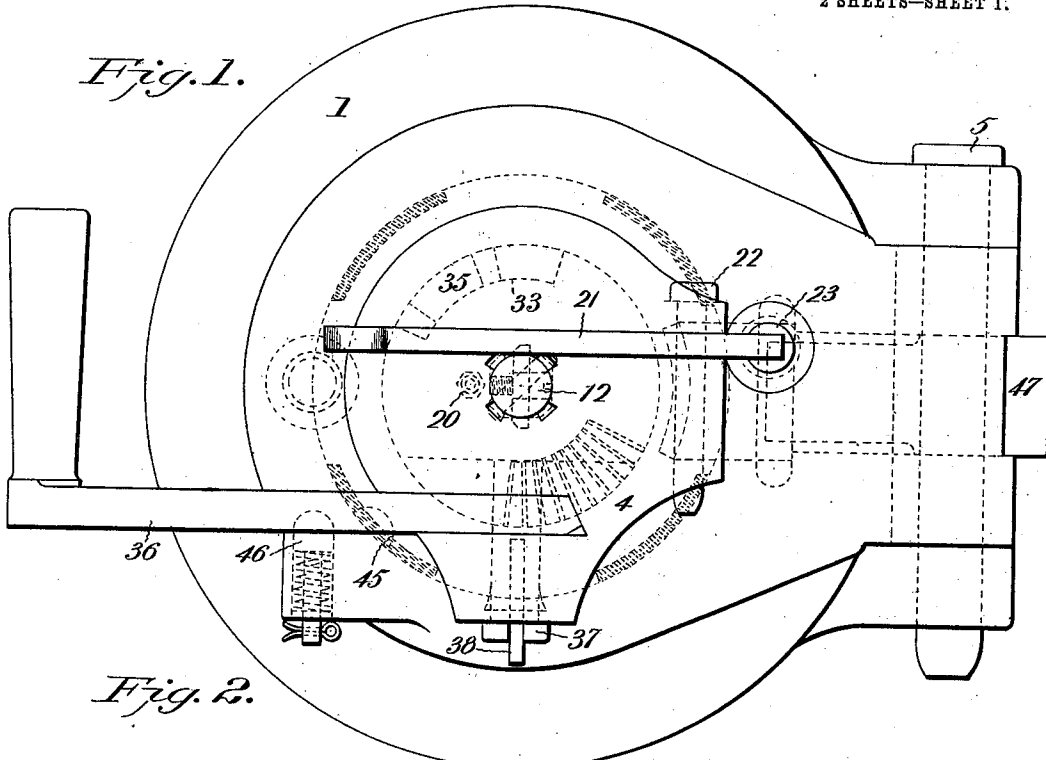
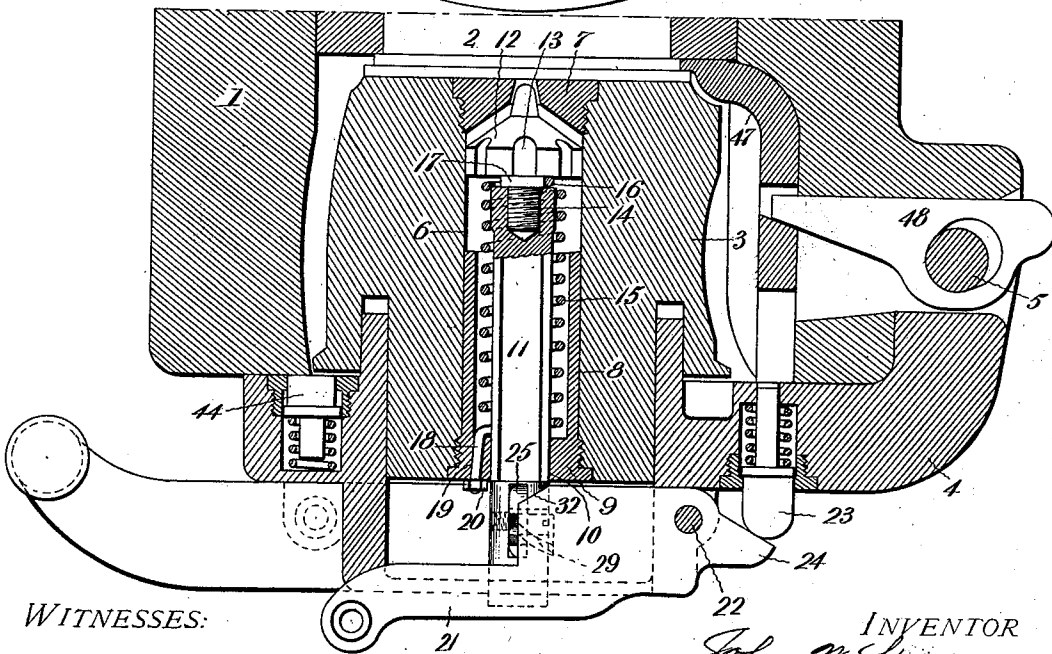

Fig. 2.



WITNESSES:

C. Walker
Adal. Briggs

INVENTOR
John W. Stockett
by *W. M. Finckel*
Attorney

No. 760,085.

PATENTED MAY 17, 1904.

J. W. STOCKETT.
BREECH MECHANISM FOR ORDNANCE.

APPLICATION FILED FEB. 1, 1902.

NO MODEL.

2 SHEETS—SHEET 2.

Fig. 3.

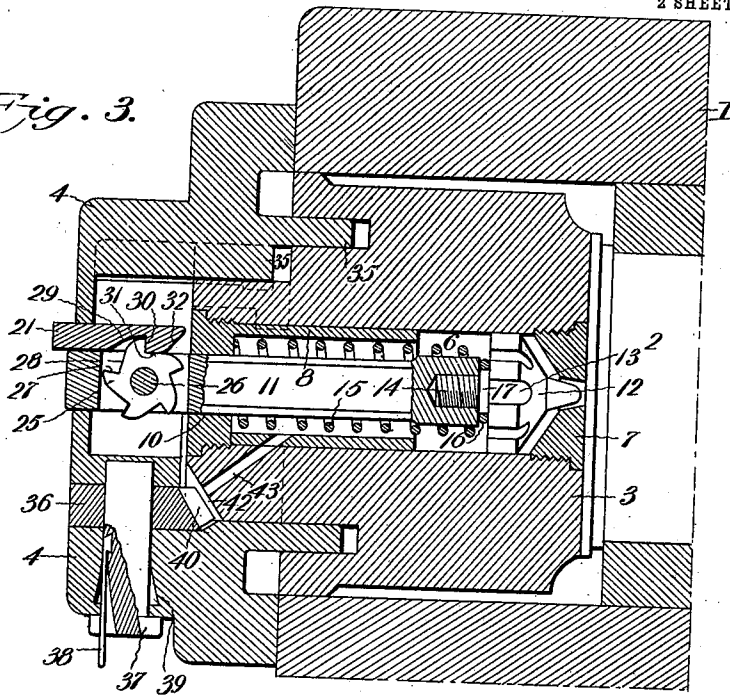

Fig. 8.

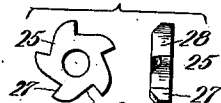

Fig. 4.

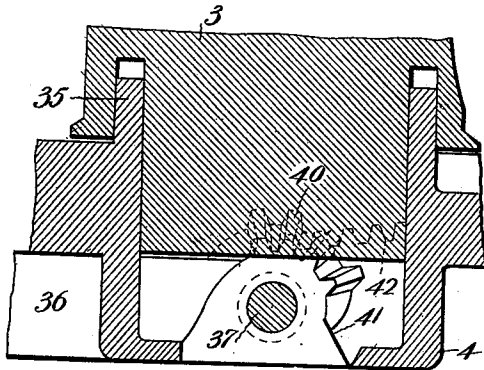
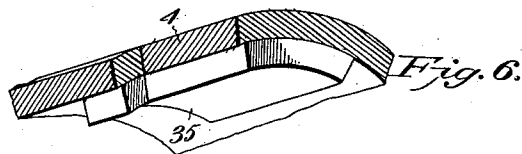
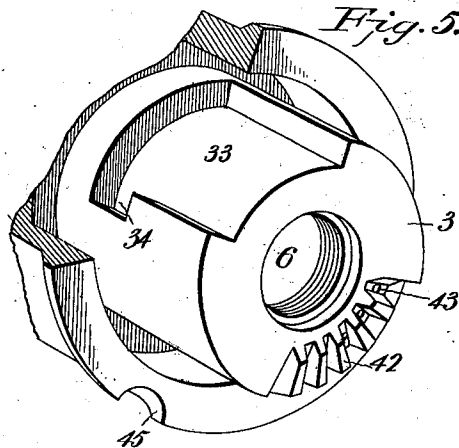

Fig. 5.



WITNESSES:

C. H. Walker,
Adala Briggs.

Fig. 7.



INVENTOR

John W. Stockett
by *Wm. F. Linnell*
Attorney

UNITED STATES PATENT OFFICE.

JOHN W. STOCKETT, OF WASHINGTON, DISTRICT OF COLUMBIA.

BREECH MECHANISM FOR ORDNANCE.

SPECIFICATION forming part of Letters Patent No. 760,085, dated May 17, 1904.

Application filed February 1, 1902. Serial No. 92,179. (No model.)

To all whom it may concern:

Be it known that I, JOHN W. STOCKETT, a citizen of the United States, residing at Washington, in the District of Columbia, have invented a certain new and useful Improvement in Breech Mechanism for Ordnance, of which the following is a full, clear, and exact description.

This invention relates to a breech mechanism for that class of breech-loading ordnance in which fixed ammunition is used; and the object of the invention is, stated very generally, to provide a simple and accurate firing mechanism with safety provisions against accidental discharge, and especially against premature action when the breech mechanism is not in completely-closed position, and as well to provide a mechanism that can be readily dismantled by hand when the breech is either opened or closed and at the same time having all the parts protected from dirt and dust. In carrying out this object and related objects of the invention, as will hereinafter more fully appear, I use a sleeve within the firing-pin chamber, which serves as a stop for the firing-pin. The breech-block carrier is hinged vertically and so as to be capable of lateral motion for opening and closing the breech and has a breech-block of the interrupted-screw variety, in which is arranged a novel spring firing-pin, between which firing-pin and the trigger is interposed a novel sear or cocking device. Between the carrier and the breech-block novel locking mechanisms are interposed to lock the block in its rotated position. The breech-operating lever and the breech-block are connected by a novel gearing, and the firing-pin chamber is vented through the breech-block and the gear-teeth cut thereon as well as through the rear face of the block around the firing-pin. The breech-lever also is provided with a novel detachable pivot-pin.

The several elements above mentioned and certain combinations thereof comprise the features of this invention, as I will proceed now more particularly to set forth and finally claim.

In the accompanying drawings, illustrating my invention, in the several figures of which

like parts are similarly designated, Figure 1 is a rear elevation. Fig. 2 is a horizontal section taken in a plane just above the trigger. Fig. 3 is a vertical section. Fig. 4 is a horizontal section just above the breech-block-operating lever. Fig. 5 is a perspective view of the rear end of the breech-block, showing especially the recess therein for cooperation with the stop and locking lug on the block-carrier, and Fig. 6 is a perspective view of the said stop-lug. Fig. 7 is a transverse section of the trigger through its notch. Fig. 8 shows in plan and edge views the sear or cocking device for the trigger.

1 represents the breech of the gun, the chamber of which is adapted to receive fixed ammunition, the rimmed head 2 only of which is shown in Figs. 2 and 3. The breech-block 3 is mounted in a block-carrier 4, pivoted upon a vertical pin 5 at the side of the gun in any usual manner. The breech-block is of the interrupted-screw variety, by preference, and it contains a chamber 6, the forward end of which is closed by a perforated anvil or cap 7, and the rearward portion of which is provided with a lining-tube 8, extending inwardly toward the front end and having a screw-head 9 tapped in the rear of the block, and having an angular opening 10 for the passage of the angular firing-pin 11, which is arranged in and supported thereby, so as to revolve with the breech-block. The firing-pin 11 has the firing-pin point 12 of a diameter substantially equal to the diameter of the bore in the breech-block and provided with peripheral notches 13 for the rearward escape of gases. This point 12 is provided with a screw-stem 14, by which it is secured to the firing-pin 11. The spring 15 has its end coil 16 of reduced diameter and encircling a collar 17 at the rear of the firing-pin point 12 and clamped between the body of said point and the end of the body of the firing-pin, while the other end 18 of said spring is passed through a hole 19 in the head 9 of the tube 8, and the rearward end of said spring is supplied with a nut 20 or other suitable device for securing and confining that end of the said spring. Thus the ends of the spring are readily accessible for renewal of the spring. The lining-tube 8 be-

ing readily removable permits the easy withdrawal of the firing-pin and its appurtenances and besides serves as a stop to limit the rearward movement of the firing-pin and spring when a blow-back occurs, thus preventing a complete compression of the spring and preserving its full elasticity and saving it from possible injury.

The trigger or firing-lever 21 is pivoted in a slot in the block-carrier on the vertically-arranged pin 22, which is secured in a portion of the said block-carrier, and the said trigger is moved into its normal position by means of a spring-pressed bolt 23, acting against a toe 24 at one end of the said trigger, and the trigger is designed to be cocked by a lanyard or other suitable device, hand-operated or otherwise. The trigger is arranged horizontally, so that when operated by a person standing to one side of the gun there will be no torsional or twisting strain imposed by the pull on the lanyard. The firing-pin carries in a slot therein a star-wheel 25 on a horizontally-arranged screw-stud 26 and upon which it is freely revoluble in one direction—forward. Each of the points or teeth of this wheel, as shown in Figs. 3 and 8, has a shoulder 27 in a substantially radial line and a base or root portion 28 in a substantially tangential line. The trigger is provided with a rearwardly and laterally curved notch 29, having a vertical face 30, and the shoulders 27 of the teeth of the wheel 25 cooperate successively with the vertical shoulder 30 of the notch in the closed position of parts, while the tangential portion 28 of said wheel cooperates with the parallel side 31 of the trigger, so that the said parallel side 31 serves as a stop which prevents any rotary motion to the rear of the wheel 25 on its pivot, so that when a pull is exerted on firing-trigger 21 the firing-pin and star-wheel as an entirety are drawn to the rear until the point of the firing-trigger is disengaged from the teeth on the wheel 25. This disengagement will occur when the trigger has been revolved around its pivot 22. The length of this rearward movement of the firing-pin can be regulated by the amount of overlap or engagement of the vertical face 30 of the trigger and the radial face 27 of the star-wheel.

The construction of the wheel 25 and the notch in the trigger 21 is such that when the trigger is drawn out in the act of cocking the firing-pin is drawn with it by virtue of the engagement of the wheel with the trigger until the trigger reaches a point in its arc of movement where the notch will free itself from the wheel, and thus the firing-pin will be released and be impelled forward by its spring. When the trigger comes back into position to reengage the wheel 25, the beveled leading end 32 of said trigger will first engage the teeth or points of the wheel and turn it upon its axial stud, and the curvature of the

notch 29 is so related to the arc of movement of the block carrying the firing-pin that there must be of necessity a proper relative positioning of the wheel and the trigger when the trigger comes to rest in its normal position. 70

The trigger, as already stated, is arranged to operate in a horizontal slot in the breech-carrier and is obviously carried by said breech-carrier, and by virtue of such arrangement and its relation to the firing-pin through the wheel it is to be noted that it is impossible for the firing-pin to be actuated prematurely, and especially before the full closing of the breech. 75

The breech-block is provided with a substantially L-shaped cavity 33, opening to the rear of the block and having an offset 34, and therewith cooperates a stop 35, of similar shape, on the block-carrier, and these two cooperating members serve to limit the rotation of the breech-block and as a hook and catch for holding the breech-block on the carrier when the mechanism is open. 80 85

The breech-lever 36 is pivoted in a slot in the breech-block carrier 4 upon a pin 37, and this pin 37 has a spring-latch 38, which engages an annular groove 39 in the pin-hole at any place of insertion, so as to retain said pin in position and at the same time permit the ready removal of the pin whenever it is desired to detach the lever. The pivot end of this lever is made with gear-teeth 40 and a shoulder 41, which shoulder serves as a stop to relieve the strain on the gear teeth in the open position of the block. The gear-teeth 40 mesh with gear-teeth 42 on the rear of the breech-block, and the arc on which the gear-teeth 42 are cut has a pitch forward equal to the pitch of the thread on the breech-block, so as to provide for the free backing out of the block in opening the breech. I utilize the space between the teeth 42 for the exit of gas through vent-holes 43, leading out of the firing-pin chamber in the breech-block. 90 95 100 105

In order to stop the further rotation of the breech-block in opening it, I provide an automatic spring-pressed bolt or buffer 44, having an annular collar and secured in the block-carrier against accidental displacement by a surrounding stop-bushing engaged by the collar and engaging a notch 45 in the edge of the block when in the rotation of said block the said notch comes opposite said bolt or buffer. In closing the breech this spring device 44 comes into contact with the rear face of the gun, and acting as a buffer obviates the ill effects upon the parts in slamming or violently closing the breech-block. 110 115 120

The operating-lever 36 may be locked in position by means of a spring-bolt 46.

47 is any ordinary ejector, combined with an ejector-lever 48, in this instance shown as having a loose engagement with the pin 5 of the breech-block carrier. 125

It will be observed that in the unlocked or open position of the gun the wheel 25, along 130

with the firing-pin, partakes of the rotary motion of the block and is moved from its normal vertical position of engagement with the trigger into an oblique position in order to throw the parts out of gear, and thus render it impossible for the gun to be fired when the block is unlocked or open. The normal operative position and the abnormal inoperative position of the wheel are respectively indicated by vertical and oblique lines in Fig. 1. In order to prevent the engagement of the wheel 25 with the notch in the trigger, the corners of the wheel are beveled, so that in the revolved position of the block the firing-trigger cannot engage the notch of the wheel and cause a premature discharge.

It will be observed that while the firing-pin has an angular portion (preferably square) in engagement with the block its outer end beyond the block and within the block-carrier and containing the star-wheel is cylindrical.

I have thus described the best mode in which at this time I have contemplated carrying out the principle of my invention, but wish to be understood as being aware that modifications of this principle are easily within the scope of the invention.

What I claim is—

1. In a breech mechanism for ordnance, a breech-block, a firing-pin mounted therein and revolving with it, a breech-block carrier, a trigger pivoted horizontally in said carrier independently of the breech-block, and means carried by the firing-pin to engage with said trigger.

2. In a breech mechanism for ordnance, a breech-block having a firing-pin chamber, and a lining-tube arranged in said chamber and extending forwardly into said chamber a distance sufficient to serve as a stop for the firing-pin when a blow-back occurs, combined with a spring arranged within said lining-tube, and a firing-pin encircled by said spring and having a head between which and the body of the pin the forward end of the spring is clamped and adapted to abut against the forward end of said lining-tube to prevent the complete compression of said spring.

3. In a breech mechanism for ordnance, a revoluble breech-block having a firing-pin chamber, a hinged breech-block carrier, and a firing-pin arranged in said chamber and having an angular connection with the breech-block so as to rotate therewith and a circular end projecting through the carrier rotatable independently thereof combined with a firing-trigger on the carrier, and means on the firing-pin for engaging said trigger, whereby the movement to unlock the block disengages the cocking means.

4. In a breech mechanism for ordnance, a breech-block containing a firing-pin chamber, a lining-tube therein, a firing-pin arranged in said tube and having a detachable shouldered

head, a spring for said firing-pin secured at one end to the lining-tube and having a coil of reduced diameter at its other end engaging the shoulder on the head and clamped between the front end of the firing-pin and the rear of the head.

5. In a breech mechanism for ordnance, a breech-block, a firing-pin, a detachable head for said pin, a lining-tube for the pin screwed into the breech-block, and a spring surrounding the pin within the lining-tube and clamped at one end between the head and the front end of the pin, and having its other end extending externally of the lining-tube and provided with a fastening device.

6. In a breech mechanism for ordnance, a longitudinally-movable firing-pin, a toothed cocking-wheel revolvably mounted upon said pin, and a notched trigger engaging said cocking-wheel and restraining it from revolving in the act of cocking the firing-pin.

7. In a breech mechanism for ordnance, a firing-pin, having a cocking-wheel constructed with a series of teeth each of which has a shouldered face and a flat root, combined with a block-carrier and a trigger positively guided in said carrier and having a shouldered notch with which and the side of the trigger the shoulder and root of the teeth of the cocking-wheel respectively engage.

8. In a breech mechanism for ordnance, a firing-pin carried by and rotating with the block, a toothed cocking-wheel having a beveled edge, a block-carrier and a trigger mounted upon said carrier and having a beveled and shouldered notch, whereby as the breech is opened, the trigger is rendered inoperative by disengagement from the said cocking-wheel consequent upon the rotation of the block carrying the cocking-wheel out of alignment with the trigger.

9. In a breech mechanism for ordnance, a block-carrier, a trigger mounted upon said carrier and having a beveled leading edge, and a shouldered notch in one face thereof, combined with a firing-pin mounted in the breech-block to rotate therewith, and a cocking device mounted upon the said firing-pin and consisting of a toothed wheel, the teeth of which are beveled on one side, and each tooth having a shoulder and a square root.

10. The combination with a breech-block having an L-shaped recess, of a correspondingly-shaped lug on the block-carrier adapted to engage said recess in the block for limiting the rotation of the breech-block and for holding the block on the carrier when the mechanism is open.

In testimony whereof I have hereunto set my hand this 31st day of January, A. D. 1902.

JOHN W. STOCKETT.

Witnesses:

WM. H. FINCKEL,

C. A. NEALE.