

(No Model.)

4 Sheets—Sheet 2.

J. SWITZER. FLAX THRESHING MACHINE.

No. 594,104.

Patented Nov. 23, 1897.

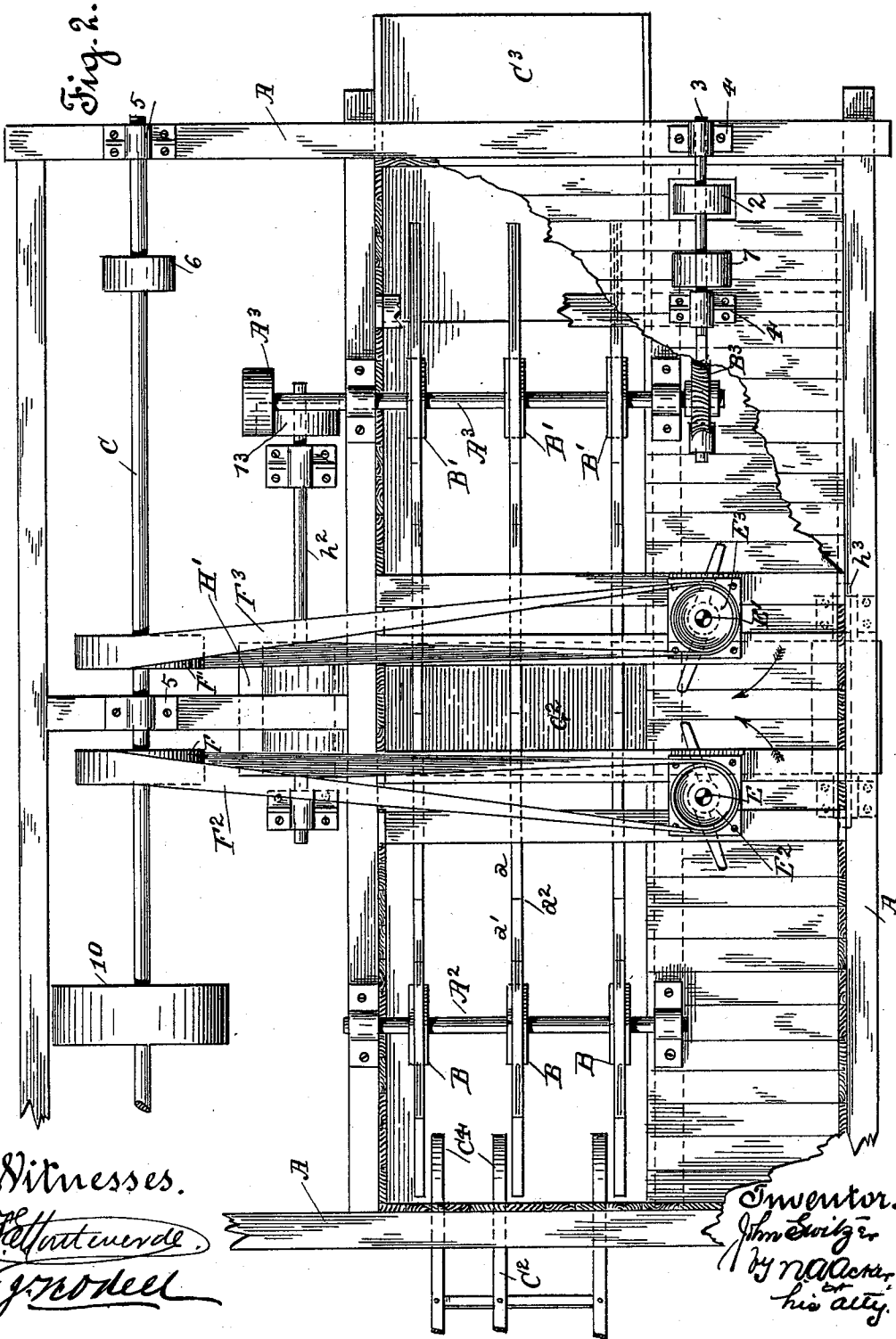

Witnesses.
W. Hartman
J. No. 104

Inventor.
John Switzer
 by *W. Hartman*
 his atty.

(No Model.)

4 Sheets—Sheet 3.

J. SWITZER.
FLAX THRESHING MACHINE.

No. 594,104.

Patented Nov. 23, 1897.

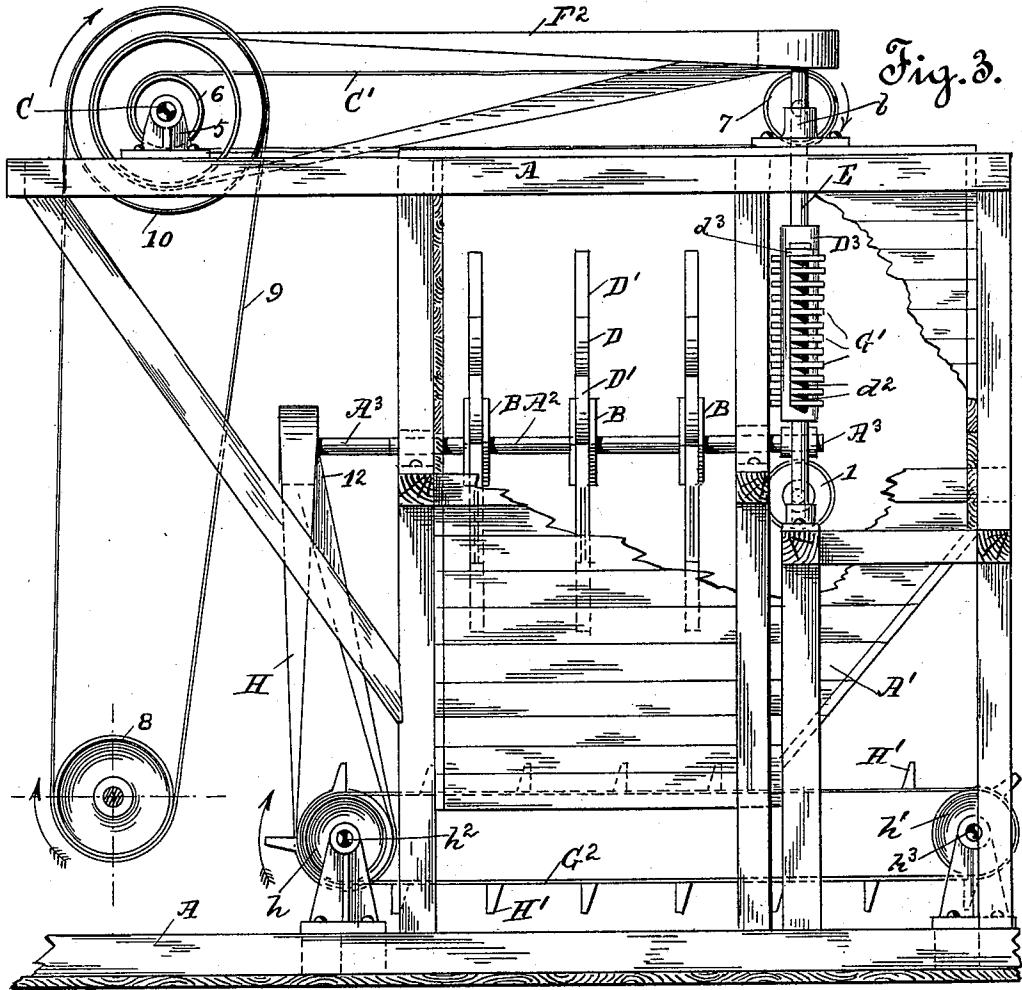

Fig. 3.

Fig. 8.

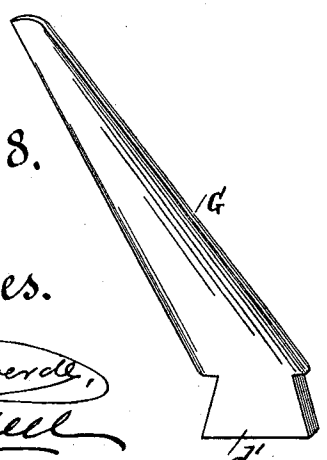
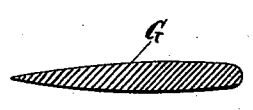

Fig. 9.



Fig. 10.



Witnesses.

J. Harteverde,
J. Modell

Inventor,
John Switzer
by *Naack*
his Atty.

J. SWITZER.
FLAX THRESHING MACHINE.

No. 594,104.

Patented Nov. 23, 1897.

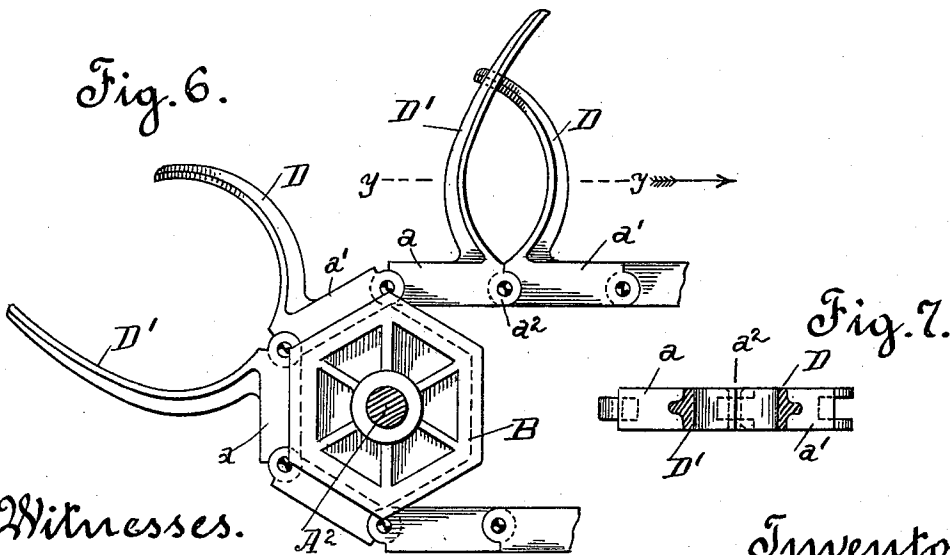
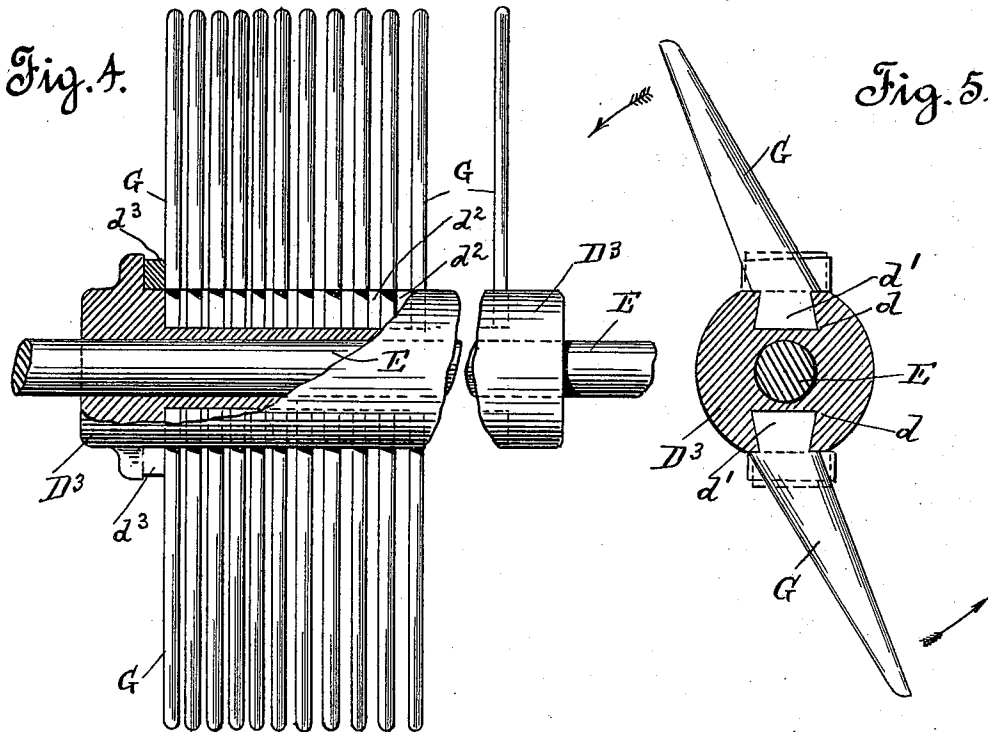

Witnesses.

J. Monteverde.
J. Modell

Inventor.
John Switzer
by *W. A. Carter*
His Atty

UNITED STATES PATENT OFFICE.

JOHN SWITZER, OF SAN FRANCISCO, CALIFORNIA.

FLAX-THRESHING MACHINE.

SPECIFICATION forming part of Letters Patent No. 594,104, dated November 23, 1897.

Application filed October 2, 1896. Serial No. 607,693. (No model.)

To all whom it may concern:

Be it known that I, JOHN SWITZER, a citizen of the United States, residing at San Francisco, in the county of San Francisco and State of California, have invented certain new and useful Improvements in Flax-Threshing Machines; and I do hereby declare that the following is a full, clear, and exact description thereof.

10 This invention relates to a certain new and useful flax threshing or separating machine which consists in the arrangement of parts and details of construction as will be hereinafter fully set forth in the drawings and described and pointed out in the specification.

15 The object of the invention is to provide a machine by means of which the seed of the flax may be separated from the straw without mutilating or damaging the straw, thus enabling the uninjured straw to be used in the manufacture of fiber.

20 In order to fully comprehend the invention, reference must be had to the accompanying sheets of drawings, forming a part of this application, wherein—

25 Figure 1 is a side view in elevation, partly broken away, of the machine. Fig. 2 is a top plan view of the mechanism illustrated in Fig. 1. Fig. 3 is an end view in elevation, partly broken, of the machine viewed from the feed end. Fig. 4 is a detail broken view of one of the comb-cylinders, the comb or separating fingers being shown in position. Fig. 5 is a cross-sectional top plan view of one of the comb-cylinders, the comb or separating fingers being in position. Fig. 6 is a broken detail view, in side elevation, showing one of the endless carriers for the flax, one of the drive-wheels, and two of the clamping-jaws secured to the endless carrier. Fig. 7 is a detail top plan cross-sectional view on line *y y*, Fig. 8 is a detail perspective view of one of the comb or separating fingers. Fig. 9 is a similar view of one of the blocks for holding the fingers apart, and Fig. 10 is a cross-sectional view of one of the comb or separating fingers.

30 In the drawings the letter A is used to designate any suitable frame or housing within which the separating or threshing mechanism for the flax is located, which frame or housing is provided with an inclined or sloping bottom

A'. Within the housing a short distance above its tapering bottom are secured in suitable bearings the cross-shafts A² A³, one near each end of the housing. Upon the shaft A² are secured the polygonal wheels B, three in number, and upon the cross-shaft A³ similar-shaped wheels B'. Over these wheels longitudinally travel the endless carriers for the bundles of flax from which the seed is to be separated, which carriers in the present case consist of three endless chains, each chain being composed of links or sections *a a'*, united by a rule-joint or hinge *a*².

35 On one end of the cross-shaft A³ is secured the worm gear-wheel B³, which meshes with the worm B⁴, secured upon the short longitudinal shaft B⁵, working in bearings within the housing A. This shaft has the belt-wheel 1 secured thereon and is driven by a belt (not shown) which passes over the belt-wheel 2 and belt-wheel 1. The belt-wheel 2 is fastened upon the shafting 3, working in bearing 4, secured to the top of the housing A, which shafting is driven by the longitudinal shaft C, working in bearing 5, through the medium of the belt C', which works over the belt-wheel 6, secured upon the shaft C near its rear end, and belt-wheel 7, secured upon the shaft 3 in advance of the belt-wheel 2. The shafting C is driven from the motor-wheel 8 by means of the endless belt 9, which works over the motor-wheel 8 and the belt-wheel 10, secured upon the shaft C, near its forward end.

40 The endless carriers have secured thereto a series of clamping-jaws which receive the bundles of flax from the feed trough or runway C² and convey the bundles past the separating devices for the flaxseed and deliver the bundles, with the seed removed, into a discharge-runway C³, which leads from the rear end of the housing. Each clamping-jaw is composed of two curved fingers or arms D D', the finger or arm D being secured to and upwardly projecting from the section or link *a'* of the endless carrier and the opposing finger or arm D' being secured to and upwardly projecting from the section or link *a* of the said carrier, which link or section is hinged to its opposing link or section *a'*. The fingers or arms being thus secured, it is obvious that they will move toward or from each

other in order to close or open the clamping-jaws as the endless carriers are carried over the drive-wheels B B'. The fingers or arms D' of each clamping-jaw are made somewhat longer than the opposing fingers or arms D in order that as the endless carriers travel over the drive-wheels B the said fingers or arms will extend or project upwardly into the lower curved end C⁴ of the feed-chute and remove the bundle or sheaf D⁵ of flax from within its seat in said chute.

Between the cross-shafts A² A³ or drive-wheels B B' are located, at one side of the endless carrier, the vertical cylinders D³ D⁴, which cylinders stand at a right angle to the horizontally-traveling endless carriers. These cylinders are secured upon the vertical shafts E E', which shafts work in bearings b b'. To the upper end of the vertical shaft E is secured the belt-wheel E², and to the upper end of the vertical shaft E' is secured the belt-wheel E³, which wheels are connected to the belt-wheels F F', respectively, secured upon the drive-shaft C, through the medium of the belts F² F³. These belts are crossed in order that the motion of the drive-shaft transmitted thereby will impart an opposite rotation to the vertical shafts E E', so that one of the cylinders D³ D⁴ will rotate in one direction while the opposing cylinder is rotated in an opposite direction.

Each cylinder is provided with two or more vertical dovetail grooves d, within which is fitted the dovetail inner end or butt d' of the comb or separating teeth G. These comb or separating teeth are formed at a gradual inclined taper in order that the outer end may stand at an angle to the inner end, Fig. 5. Between each tooth are inserted within the dovetail grooves of the vertical cylinders the separating-blocks d². The blocks d² may vary in thickness, so as to increase or decrease the distance between the comb or separating fingers or teeth in order to adapt the teeth to successfully act upon the various grades of the flax to be threshed or separated. When the teeth are in position, two rows or combs will be provided for each cylinder, Fig. 4. In building the rows of teeth a tooth is first inserted or forced down in the dovetail grooves of the cylinders and then a separating-block, and so on until the row of teeth has been constructed, when the teeth and separating-block of each row are secured in position by the key d³.

Within the inclined bottom of the housing or frame is arranged the transverse endless conveyer-belt G², which belt travels over drums h h', secured, respectively, upon the short shafts h² h³, located at each side of the housing. The motion of the cross-shaft A³ is transmitted to the shaft h² in order to drive the conveyer-belt through the medium of the endless belt H, which belt passes over a belt-wheel 12, secured upon one end of the cross-shaft A³, and over a belt-wheel 13, secured upon the shaft h². The conveyer-belt G² is

provided with a series of upwardly-projecting blades or plates H', located equidistant apart. The flax-seeds as separated from the flax fall upon this transverse conveyer-belt between the blades or plates H' and are carried by said belt to one side and deposited upon an elevator, (not shown,) which conveys the seed to any suitable place for further treatment.

Motion being imparted to the various shaftings in order to set in motion the different parts operated thereby, the separation of the seed from the flax will be as follows: The bundle or sheaf D⁵ of flax is fed into the machine by the runway or chute C², the lower bundle or sheaf resting in the curved end or seat C⁴ of the chute. As the endless carriers are carried around or over the polygonal drive-wheels B B' the clamping-jaws will approach the bundle or sheaf in an open position; and as the jaws move past the curved end of the runway the extended portion of the arm D' will pass beneath the lowermost bundle or sheaf of flax, raise the same from within its seat, and deposit it between the arms D D'. The hinged links or sections a a' of the endless carrier as moved over the faces of the driving-wheels gradually assume a straight line or come together, so as to close the arms of the clamping-jaws tightly or firmly around the sheaf or bundle of flax deposited therebetween. Inasmuch as the sections or links a a', composing the carriers, are united by a rule-joint or hinge it is obvious that, as the clamping-jaws move beyond the forward drive-wheels B, that portion of the carriers between the drive-wheels B B' will form a rigid bar. The bundle or sheaf being firmly clamped is carried past the first set of comb or separating fingers secured within the rotating vertical cylinder D³. As the bundle or sheaf moves past this cylinder, which we will suppose to be revolving from right to left, the vertical rows of teeth or fingers will enter between the heads of the flax and thresh or beat out the seeds from the straw or stalk, the teeth or arms, owing to their peculiar shape, striking the seed or grain at an angle. The bundle or sheaf being carried past the first set of comb or separating fingers is met by the second set mounted in the rotatable vertical cylinder D⁴. These teeth, as the cylinder D⁴ is revolved in an opposite direction to the cylinder D³, beat or move through the bundle opposite to the teeth of the cylinder D³, thus threshing out all seeds left by the fingers of the first cylinder. By the time the bundle of flax is moved or carried out of reach of the second set of teeth all seeds will have been threshed out of the straw or bundle. The seed as separated or threshed out fall into the inclined bottom of the housing and are deposited upon the endless conveyer G², by means of which it is conveyed to a suitable place of deposit. The links of the endless carriers as moved over the drive-wheels B' gradually turn downward or move

apart, so as to open the arms of the clamping-jaws and permit the threshed bundle of flax to roll therefrom into the discharge chute or runway C³, by means of which it is conveyed from within the housing of the machine. Of course it will be understood that the bundles or sheaves of flax are fed into the machine with the heads thereof toward the revolving comb or separating fingers.

While three endless carriers have been shown and three polygonal drive-wheels mounted upon each cross-shaft A² A³, it is obvious that only one endless carrier and only one drive wheel or cylinder for each cross-shaft need be employed.

By the use of this machine the straw of the flax during the operation of threshing or separating the seed is not damaged or injured and when discharged from the machine may be successfully utilized for the manufacture of fiber. Each sheaf or bundle during the travel of the endless carrier is automatically removed from within the feed-chute, clamped, and after being threshed or having the seeds removed is likewise discharged from the clamping-jaws.

Having thus described the invention, what is claimed as new, and desired to be protected by Letters Patent, is—

1. In a flax-threshing machine, the combination with the horizontally-traveling endless-chain carrier composed of a series of links united by a rule-joint, of the end wheels over which said carrier travels, of mechanism for driving one of said wheels, the automatically opening and closing clamping-jaws secured to and operated by the travel of the horizontally-traveling endless carrier over the end wheels, said jaws consisting of two curved fingers or arms which are secured to opposing links of the carrier, and of the vertically-arranged rotary threshing devices located between the end wheels, which devices thresh the bundles of sheaves as carried past by the endless carrier.

2. In a flax-threshing machine, the combination with the horizontally-traveling endless-chain carrier said carrier consisting of a series of links united by a rule-joint, of mechanism for driving the same, a series of clamping devices for receiving and holding the bundles secured to and carried and operated by the movement of the endless carrier, each clamping device consisting of two fingers or arms secured to opposing links of the carrier, and of vertically-arranged rotating devices for threshing the bundles or sheaves as carried by the endless carrier.

3. In a threshing-machine for flax, the combination with the horizontally-traveling endless-chain carrier, of the end wheels over which said endless-chain carrier travels, mechanism for driving one of said end wheels, a series of automatically-operated clamping devices for the bundles or sheaves secured to and carried and operated by the movement of the endless carrier, and of the vertically-arranged

rotary threshing devices arranged at a right angle to the endless carrier and which during their rotary movement separate the seed from the flax as the bundles are carried past the same, and of mechanism for rotating the threshing devices in opposite directions.

4. In a flax-threshing machine, the combination of an endless horizontally-traveling chain carrier composed of a series of links or sections united by a rule-joint, of the end wheels over which the said carrier travels, a series of clamping-jaws composed of two curved arms each arm being secured to an independent link or section of the endless carrier, mechanism for driving the endless carrier and causing the clamping-jaws to automatically close and open in order to clamp the bundles or sheaves and discharge the same, of devices rotating in a plane at an angle to the traveling carrier in order to separate the seed from the flax, and of mechanism for rotating the threshing device in opposite directions.

5. In a flax-threshing machine, the combination with the horizontally-traveling endless-chain carrier composed of a series of links united by a rule-joint, of the end wheels which support and over which the endless-chain carrier travels, a series of automatically opening and closing clamping devices for the bundles or sheaves secured to and carried and operated by the movement of the carrier, each clamping device consisting of a pair of fingers or arms which are secured to opposing links of the carrier, mechanism for driving the carrier, a cylinder arranged at an angle to the endless carrier, mechanism for imparting rotary movement to the cylinder, and of the comb or separating teeth or fingers removably secured to and carried by the said cylinder, which teeth or fingers as carried around engage the head of the bundles or sheaf of flax and remove or separate the seed therefrom.

6. In a flax-threshing machine, the combination with the endless horizontally-traveling chain carrier, of the end wheels which support and over which the endless carrier works, the clamping devices secured to and carried and operated by the movement of said carrier, mechanism for driving the said endless carrier, a pair of rotating comb-cylinders carrying comb teeth or fingers arranged at an angle to the endless carrier, the comb teeth or fingers of which cylinders engage with the head of the bundles held within the clamping devices and separate the seed therefrom, and of mechanism for communicating opposite rotation to the two comb-cylinders.

In testimony whereof I affix my signature, in presence of two witnesses, this 11th day of August, 1896.

JOHN SWITZER.

Witnesses:

LEE D. CRAIG,
N. A. ACKER.