

D. C. Cregier.

Dredging Machine.

N^o 79,448.

Patented Jan. 30, 1868.

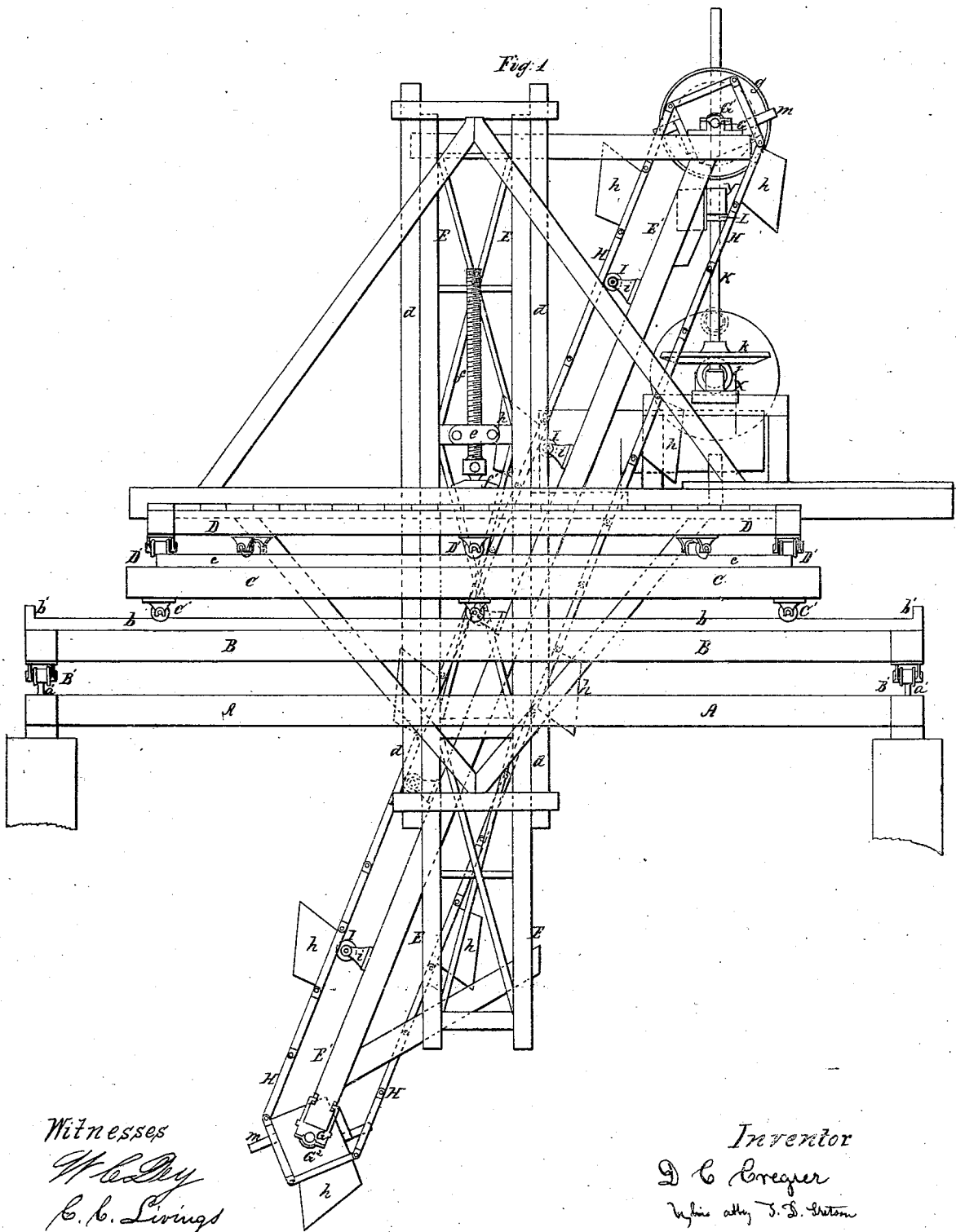

Witnesses
W. C. Day
C. C. Livings

Inventor
D. C. Cregier
Wm. C. Day, J. D. Weston

D. C. Cregier.

Dredging Machine.

No 79,448.

Patented Jan. 30, 1868.

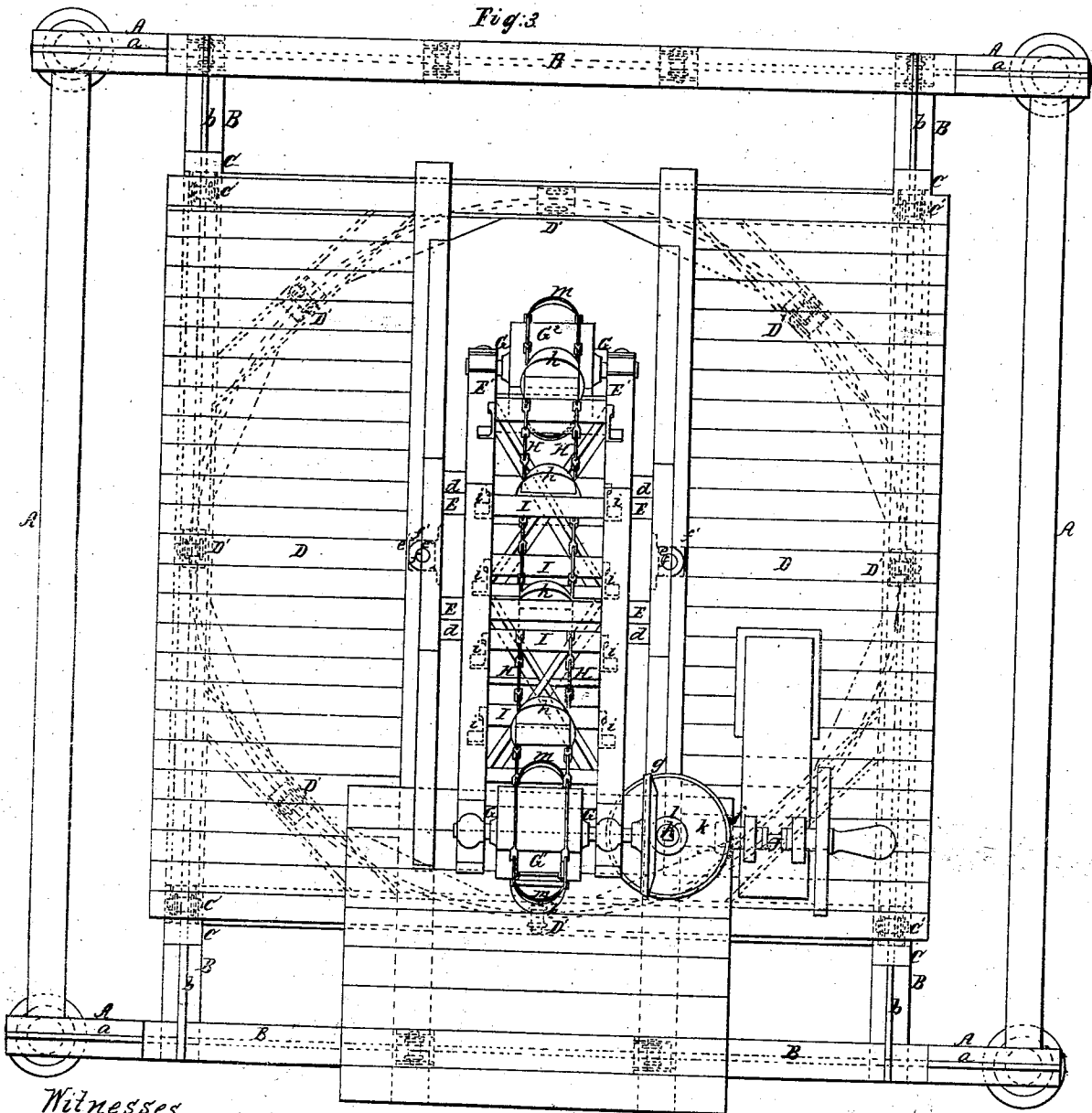

Witnesses
 W. C. Dey
 C. C. Loring

Inventor
 D. C. Cregier
 by his attorney, W. D. Stearns

UNITED STATES PATENT OFFICE.

D. C. CREGIER, OF CHICAGO, ILLINOIS.

IMPROVED DREDGING-MACHINE.

Specification forming part of Letters Patent No. 79,428, dated June 30, 1868.

To all whom it may concern:

Be it known that I, DEWITT C. CREGIER, of Chicago, in the county of Cook, in the State of Illinois, have invented certain new and useful Improvements in Dredging-Machines; and I do hereby declare that the following is a full and exact description thereof.

My improved dredger will serve for dredging bars, rivers, &c., like other dredging-machines, but is more especially adapted for dredging in contracted spaces and to definite points, as in preparing the foundations for piers for bridges, sinking shafts of any kind in a soft or diversified bottom, dredging in contracted angles of docks, and the like.

I will first describe what I consider the best means of carrying out my invention, and will afterwards designate the points which I believe to be new therein.

The accompanying drawings form a part of this specification.

Figure 1 is a side elevation of the entire machine supported on fixed posts or a fixed foundation, which represents the piling or other work around the space to be dredged. Fig. 2 is an end elevation of the same. Fig. 3 is a plan view of the same.

Similar letters of reference indicate like parts in all the figures.

Tints are used to aid in distinguishing parts, and do not indicate material. The material of the main portions of the frame-work is wood. The material of the chains, scoops, &c., and of most of the small work, friction-rollers, straps, &c., may be iron and steel.

A is a fixed frame-work, supporting rails or ways *a a*, having stops at each end, as indicated by *a'*.

B is a frame supported on rollers *B'*, which run on the rails *a'*. The frame B is adapted to traverse on the ways *a a*, and may be moved by rack and pinion, pulleys, or other ordinary mechanism. (Not represented.) The frame-work B carries rails or ways *b*, provided with stops at each end, as indicated by *b'*.

C is a frame supported on rollers *C'*, which run on the ways *b*. The frame C is adapted to traverse on the ways *b* in a direction transverse to the position of the ways *a*. It may be moved by rack and pinion or otherwise. The frame C carries a circular track, *c*.

D is a frame running on rollers *D'*, adapted to traverse on the circular track *c*. The frame

D and the parts supported thereon may be turned round on the circular track *c* by the aid of rack and pinion or other means. (Not represented.) The frame D carries upright guides *d*, firmly braced, as represented. The dredging mechanism proper is supported between these upright guides, and is adapted to rise and sink therein, while it may be turned round by the motion of the turning-frame D without stopping the operation of dredging. This may be carried to the right and left by the motion of the transverse frame C, and may be carried forward and back by the motion of the longitudinal frame B.

E is a vertical frame-work, and *E'* is an inclined frame-work, the whole being firmly connected and braced so as to operate as a single piece. It carries stout threaded brackets *e*, which are adapted to receive stout vertical screws *f f*, which screws are supported at their lower ends in sockets *f'* on the frame-work D. These screws may be turned by hand or otherwise, and thereby the entire frame-work *E E'* and its connections are raised and lowered by the ways or guides *d*.

Revolving shafts *G G* are mounted at the upper and lower ends of the inclined portion *E'* of the above-described frame-work. The upper shaft is provided with a bevel-gear wheel, *g*. The upper shaft carries a square drum or block, *G'*, and the lower shaft carries a corresponding square drum or block, *G''*. The length of the flat faces of these drums corresponds to the links of the stout endless pitch-chains *H*, which traverse around them and carry the buckets or shovels *h*, as represented. Anti-friction rollers *II* are mounted on brackets *i* on the upper inclined face of *E'*, which aid in supporting the weight of the pitch-chains *H H*, and their loaded buckets. The motion of these chains *H* and the action of the buckets *h* in excavating the earth which they meet in their revolution are analogous to the operation of corresponding parts in other dredging-machines. The means by which they are operated so as not to interfere with the various motions above provided is novel.

J is a shaft, rotated by a steam-engine or other suitable power carried on the platform or frame-work D. The small bevel-gear wheel *j*, fixed on this shaft J, meshes into a larger bevel-gear wheel, *k*, which is mounted on an upright square shaft, *K*, which latter is sup-

ported on the frame-work D by starting in a step, X, at the foot, and turning in a bracket, Y, above, as represented.

L is a sleeve, square on the inside and matching smoothly to the surface of the square shaft K. Its exterior is fitted in the bracket Y, so that it can turn around freely, but cannot move up or down. The upper end of this sleeve L carries a bevel-gear wheel, *l*, which meshes into the bevel-gear wheel *g*, above described. It follows that when the engine-shaft J is actively rotated it imparts a rotatory motion to the square shaft K, and thus, through the sleeve L and gear-wheel *g*, to the upper square drum, G'. This compels the chains H and the buckets *h* to traverse continually around, the buckets descending on the under side of the inclined frame, turning round the lower square block, G², and rising loaded on the upper side, bringing up whatever earth is taken in the shovels or buckets and pouring it into a suitable chute or other receptacle. (Not represented.)

The above-described mechanism allows my buckets *h* to excavate with very great precision at any desired depth, and to be traversed along as rapidly as may be required in either direction. It may also be presented in any direction—east, northeast, &c.—which may be found desirable in practice by turning the uppermost frame-work, D.

The parts G' G², which I have described as square blocks or drums, are not plane on all their faces. Two of the faces are provided with stout guides, formed and arranged as indicated by *m*, which are adapted to just fill the space between the two chains H H, and to keep the buckets very correctly in position. If there is a tendency to press the shovels *h* to one side from any cause—as the presence of hard earth on one side, or of bowlders, or some wooden or other obstruction—such tendency is resisted by the contact of the chains against the guides *m*. The arching form of the guides *m* effectually avoids any danger of the chains riding on the guides.

I can operate with some success in most situations by mounting the shafts G and the connected buckets, &c., on the upright frame E and omitting the inclined frame E'; but I greatly prefer to employ the inclined frame E', as otherwise much of the advantage properly due to the provisions for raising and lowering, turning and moving bodily in every direction, cannot be fully made available.

I have described the upright shaft K as square and the interior of the sleeve L as correspondingly formed. It may be preferable in ordinary practice to make the shaft K cylindrical and to make the interior of the sleeve L of a corresponding form, and to provide each with a spline or longitudinal groove carrying a feather or loose key which fits in each. This construction or any other I consider equivalent so long as it allows the sleeve L to move freely up and down on the shaft K while it is compelled to revolve therewith.

I have represented the screws *f* as adapted to be operated by hand. They may be operated by steam or other power through any suitable gearing or other connection; or the screws may be replaced by racks and pinions or other ordinary mechanical devices for raising and lowering. It is simply necessary to the success of this portion of my invention that the frame-work E E' and its connections be strongly and reliably supported by means which will allow its elevation to be adjusted at will.

All the movements of the several frames, B C, &c., may be effected by steam-power through the agency of ropes and windlasses, pulleys, or the like.

Having now fully described my invention, what I claim as new therein, and desire to secure by Letters Patent, is as follows:

1. The guides *d* and screws *f*, with the shaft K and bevel-pinion *k* and their connections, in combination with the vertical frame-work E and its connections, adapted to transmit the power at any elevation, as and for the purposes herein set forth.
2. The inclined frame-work E', mounted on the upright frame E, as represented, and adapted to be adjusted in the several directions, and operating the dredging mechanism H *h* in an inclined position, while the rising and lowering motion may be vertical, as and for the purposes herein specified.
3. The guides *m*, formed and arranged as represented, on the revolving parts G' G², and adapted to guide the pitch-chains H, and consequently to control very exactly the working-paths of the buckets *h*, or their equivalents, as and for the purposes herein specified.

D. C. CREGIER.

Witnesses:

ABIEL W. TINKHAM,
E. S. CHESBROUGH.