

S. R. BRYANT.

Improvement in Carriage-Wheels.

No. 130,621.

Patented Aug. 20, 1872.

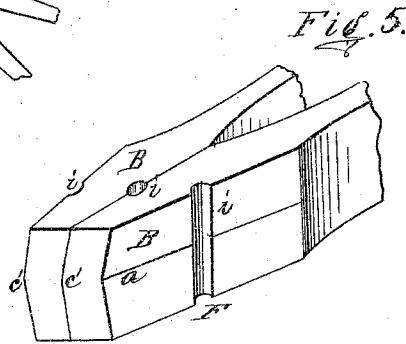
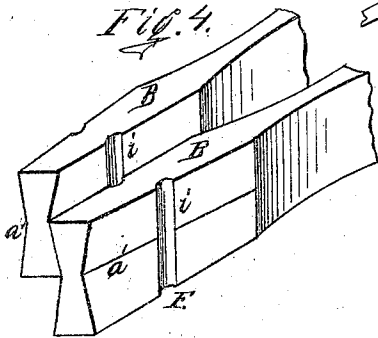
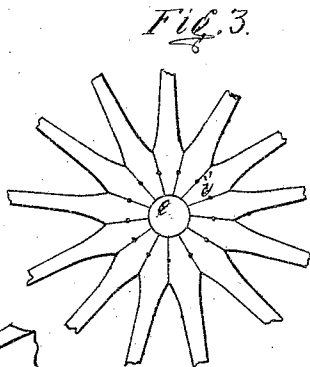
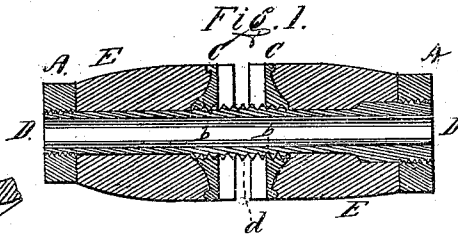
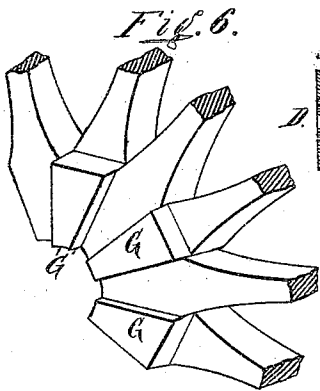
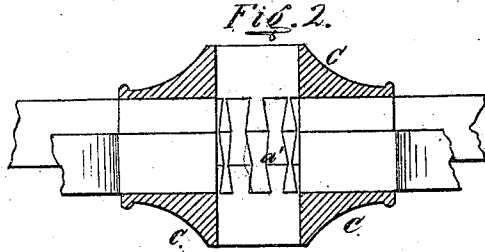

Witnesses.

J. W. Bowman
H. Smith

Inventor.

S. R. Bryant

UNITED STATES PATENT OFFICE.

SAMUEL R. BRYANT, OF WATERFORD, PENNSYLVANIA.

IMPROVEMENT IN CARRIAGE-WHEELS.

Specification forming part of Letters Patent No. 130,621, dated August 20, 1872.

Specification describing a new and Improved Carriage-Wheel, invented by SAMUEL R. BRYANT, of Waterford, in the county of Erie and State of Pennsylvania.

Figure 1 is a sectional elevation of the hub of my improved carriage-wheel. Fig. 2 is a horizontal section of the metal disks between which the spokes are clamped. Fig. 3 shows the spokes arranged to present a plain face or surface. Fig. 4 shows their form and arrangement when arranged zigzag. Fig. 5 shows the same mode of locking with the spokes arranged to present a plain face, as in Fig. 3. Fig. 6 shows the zigzag arrangement of spokes with wedges filling the spaces between them.

My invention relates to the mode of locking the spokes by means of grooves and wedges, and the mode of fitting the spokes and pipe-box together, as hereinafter described.

In the drawing, D represents the pipe-box; E E, the wooden portions of the hub; C C, the metal-ribbed disks, between which the spokes are secured; and A A, the nuts on the ends of the pipe-box, which serve to clamp the parts E between themselves and the disks C. The disks are screwed upon the pipe-box at *b*, and a preferably coarser thread is formed on the central portion *d* of the box, to adapt it to be screwed into the tubular opening formed by the converging ends of the spokes, as shown at *e*, Fig. 3. This mode of connecting the spokes and pipe-box may be employed with either a zigzag or plain-faced arrangement of the former, and the disks C C will, in either case, clamp the spokes between them.

To lock together the spoke tenons so that

lateral movement of one upon the other shall be prevented, I form longitudinal grooves in their contiguous surfaces. If the wheel is to be plain-faced, as in Fig. 3, I form a groove, *a*, in but one side of each spoke-tenon B, and form a corresponding rib or beveled projection, *a'*, on the other side. Thus the spokes fit together, as in Fig. 5. If the spokes are to be arranged zigzag, as in Fig. 6, I form a groove, *a*, in each side of the same, so that they fit or lock together, as in Fig. 4.

To prevent longitudinal movement of the spokes one upon another, transverse perforations may be formed, as shown at *i*, Figs. 3, 4, and 5, to receive locking-pins of any suitable material. This expedient has, however, been employed by others.

When the spokes are arranged zigzag, as in Figs. 4 and 6, spaces are formed between them and the inner sides of the disks C. I fill these spaces by wedges G, and thus still further lock the spokes together.

What I claim as new, and desire to secure by Letters Patent, is—

1. The combination of the pipe-box D, screw-threaded, as shown, the metallic disks C C, and spoke-tenons B, arranged as specified.
2. The mode of locking the spoke-tenons by means of longitudinal grooves and beveled shoulders, as specified.
3. The wedges G, arranged with the zigzag spokes.

SAMUEL R. BRYANT.

Witnesses:

JOHN BOWMAN,
HUNTER SMITH.