

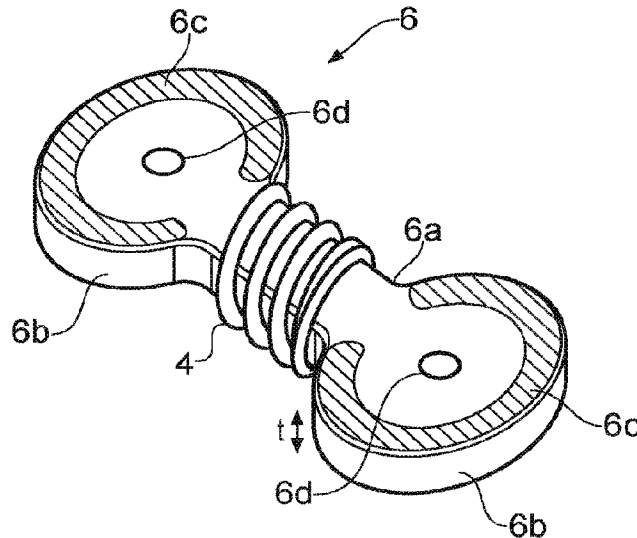

(86) Date de dépôt PCT/PCT Filing Date: 2019/01/23
 (87) Date publication PCT/PCT Publication Date: 2019/08/01
 (45) Date de délivrance/Issue Date: 2023/03/21
 (85) Entrée phase nationale/National Entry: 2020/07/21
 (86) N° demande PCT/PCT Application No.: GB 2019/050186
 (87) N° publication PCT/PCT Publication No.: 2019/145709
 (30) Priorité/Priority: 2018/01/24 (GB1801144.5)

(51) Cl.Int./Int.Cl. *A24F 47/00* (2020.01)
 (72) Inventeurs/Inventors:
 POTTER, MARK, GB;
 TIPTON, WADE, GB;
 HARRIS, WILLIAM, GB;
 ROWE, CHRISTOPHER, GB;
 DAVIES, JAMES, GB;
 BOONZAIER, JAMES, GB;
 DEVINE, CONOR, GB
 (73) Propriétaire/Owner:
 NICOVENTURES TRADING LIMITED, GB
 (74) Agent: BERESKIN & PARR LLP/S.E.N.C.R.L.,S.R.L.

(54) Titre : SOURCE D'AEROSOL POUR UN SYSTEME DE FOURNITURE DE VAPEUR
 (54) Title: AEROSOL SOURCE FOR A VAPOUR PROVISION SYSTEM



(57) **Abrégé/Abstract:**

An aerosol source for a vapour provision system comprises a vapour-generating element; a reservoir for holding source liquid, the reservoir being bounded by a wall having an opening therein; and a liquid transport element comprising a first portion arranged to receive liquid from the reservoir via the opening, a second portion peripheral to the first portion, and a third portion arranged to deliver liquid from the first portion to the vapour-generating element; wherein at least part of the second portion is compressed against a section of the wall around the opening, in use, to provide a sealing effect around at least part of the first portion to promote movement of liquid towards the vapour-generating element.

(12) INTERNATIONAL APPLICATION PUBLISHED UNDER THE PATENT COOPERATION TREATY (PCT)

(19) World Intellectual Property
Organization
International Bureau

(43) International Publication Date
01 August 2019 (01.08.2019)



(10) International Publication Number
WO 2019/145709 A1

(51) International Patent Classification:

A24F 47/00 (2006.01)

(21) International Application Number:

PCT/GB2019/050186

(22) International Filing Date:

23 January 2019 (23.01.2019)

(25) Filing Language:

English

(26) Publication Language:

English

(30) Priority Data:

1801144.5 24 January 2018 (24.01.2018) GB

(71) Applicant: NICOVENTURES TRADING LIMITED

[GB/GB]; Globe House, 1 Water Street, London WC2R 3LA (GB).

(72) Inventors: POTTER, Mark; c/o Nicoventures Trading

Limited, Globe House, 1 Water Street, London WC2R 3LA (GB). TIPTON, Wade; c/o Nicoventures Trading Limited, Globe House, 1 Water Street, London WC2R 3LA (GB). HARRIS, William; c/o Nicoventures Trading Limited, Globe House, 1 Water Street, London WC2R 3LA (GB). ROWE, Christopher; c/o Nicoventures Trading Limited,

Globe House, 1 Water Street, London WC2R 3LA (GB).

DAVIES, James; c/o Nicoventures Trading Limited, Globe House, 1 Water Street, London WC2R 3LA (GB). BOON-

ZAIER, James; c/o Nicoventures Trading Limited, Globe House, 1 Water Street, London WC2R 3LA (GB). DE-

VINE, Conor; c/o Nicoventures Trading Limited, Globe House, 1 Water Street, London WC2R 3LA (GB).

DAVIES, James; c/o Nicoventures Trading Limited, Globe House, 1 Water Street, London WC2R 3LA (GB).

DE-VINE, Conor; c/o Nicoventures Trading Limited, Globe House, 1 Water Street, London WC2R 3LA (GB).

DAVIES, James; c/o Nicoventures Trading Limited, Globe House, 1 Water Street, London WC2R 3LA (GB).

(74) Agent: MCGOWAN, Cathrine; c/o D Young & Co LLP,

120 Holborn, London EC1N 2DY (GB).

(81) Designated States (unless otherwise indicated, for every

kind of national protection available): AE, AG, AL, AM,

AO, AT, AU, AZ, BA, BB, BG, BH, BN, BR, BW, BY, BZ,

CA, CH, CL, CN, CO, CR, CU, CZ, DE, DJ, DK, DM, DO,

DZ, EC, EE, EG, ES, FI, GB, GD, GE, GH, GM, GT, HN,

HR, HU, ID, IL, IN, IR, IS, JO, JP, KE, KG, KH, KN, KP,

KR, KW, KZ, LA, LC, LK, LR, LS, LU, LY, MA, MD, ME,

MG, MK, MN, MW, MX, MY, MZ, NA, NG, NI, NO, NZ,

OM, PA, PE, PG, PH, PL, PT, QA, RO, RS, RU, RW, SA,

SC, SD, SE, SG, SK, SL, SM, ST, SV, SY, TH, TJ, TM, TN,

TR, TT, TZ, UA, UG, US, UZ, VC, VN, ZA, ZM, ZW.

(84) Designated States (unless otherwise indicated, for every

kind of regional protection available): ARIPO (BW, GH,

(54) Title: AEROSOL SOURCE FOR A VAPOUR PROVISION SYSTEM

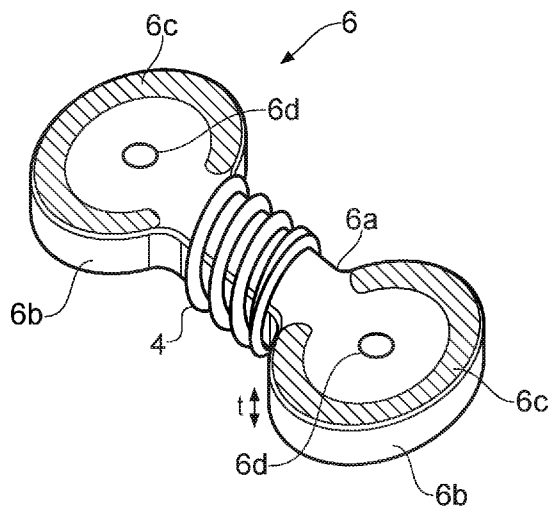

FIG. 3

(57) **Abstract:** An aerosol source for a vapour provision system comprises a vapour-generating element; a reservoir for holding source liquid, the reservoir being bounded by a wall having an opening therein; and a liquid transport element comprising a first portion arranged to receive liquid from the reservoir via the opening, a second portion peripheral to the first portion, and a third portion arranged to deliver liquid from the first portion to the vapour-generating element; wherein at least part of the second portion is compressed against a section of the wall around the opening, in use, to provide a sealing effect around at least part of the first portion to promote movement of liquid towards the vapour-generating element.



WO 2019/145709 A1

WO 2019/145709 A1 

GM, KE, LR, LS, MW, MZ, NA, RW, SD, SL, ST, SZ, TZ,
UG, ZM, ZW), Eurasian (AM, AZ, BY, KG, KZ, RU, TJ,
TM), European (AL, AT, BE, BG, CH, CY, CZ, DE, DK,
EE, ES, FI, FR, GB, GR, HR, HU, IE, IS, IT, LT, LU, LV,
MC, MK, MT, NL, NO, PL, PT, RO, RS, SE, SI, SK, SM,
TR), OAPI (BF, BJ, CF, CG, CI, CM, GA, GN, GQ, GW,
KM, ML, MR, NE, SN, TD, TG).

Published:

— *with international search report (Art. 21(3))*

AEROSOL SOURCE FOR A VAPOUR PROVISION SYSTEM

Technical Field

The present disclosure relates to an aerosol source for an electronic vapour provision system such as an e-cigarette.

Background

Many electronic vapour provision systems, such as e-cigarettes and other electronic nicotine delivery systems that deliver nicotine via vaporised liquids, and hybrid devices which additionally include a portion of tobacco or other flavour element through which vapour generated from a liquid is passed, are formed from two main components or sections, namely a cartomiser and a control unit (battery section). The cartomiser generally includes a reservoir of liquid and an atomiser for vaporising the liquid. These parts may collectively be designated as an aerosol source. The atomiser may be implemented as an electrical (resistive) heater, such as a wire formed into a coil or other shape, and a wicking element in proximity to the heater which transports liquid from the reservoir to the heater. The control unit generally includes a battery for supplying power to the atomiser. Electrical power from the battery is delivered to the heater, which heats up to vaporise a small amount of liquid delivered by the wicking element from the reservoir. The vaporised liquid is then inhaled by the user.

The reservoir has at least one opening by which liquid can leave the reservoir to flow along the wicking element. Leakage may occur at this opening. Also, sometimes the wicking element may absorb more liquid than the heater is able to vaporise, for example in the event of environmental pressure changes or physical shocks. This gives an excess of free liquid in the wicking element, which can result in leakage. Liquid may drip from the base of the atomiser, for example. Accordingly, approaches for reducing liquid leaks are of interest.

Summary

According to a first aspect of some embodiments described herein, there is provided an aerosol source for a vapour provision system comprising: a vapour-generating element; a reservoir for holding source liquid, the reservoir being bounded by a wall having an opening therein; and a liquid transport element comprising a first portion arranged to receive liquid from the reservoir via the opening, a second portion peripheral to the first portion, and a third portion arranged to deliver liquid from the first portion to the vapour-generating element; wherein at least part of the second portion is compressed against a section of the wall around the opening, in use, to provide a sealing effect around at least part of the first portion to promote movement of liquid towards the vapour-generating element.

According to a second aspect of some embodiments described herein, there is provided a vaporiser for a vapour provision system comprising a vapour-generating element for generating vapour from a liquid; and a liquid transport element comprising a first portion configured to receive liquid from a reservoir via an opening in a wall of the reservoir, a second portion peripheral to the first portion and configured for compression against a section of wall around the opening, and a third portion configured to deliver liquid from the first portion to the vapour-generating element.

According to a third aspect of some embodiments described herein, there is provided a liquid transport element for a vapour provision system comprising a first portion configured to receive liquid from a reservoir via an opening in a wall of the reservoir, a second portion peripheral to the first portion and configured for compression against a section of wall around the opening, and a third portion configured to deliver liquid from the first portion to a vapour generating element configured to generate vapour from the liquid.

According to a fourth aspect of some embodiments described herein, there is provided a cartomiser for a vapour provision system comprising an aerosol source according to the first aspect, a vaporiser according to the second aspect or a liquid transport element according to the third aspect.

According to a fifth aspect of some embodiments described herein, there is provided a vapour provision system comprising an aerosol source according to the first aspect, a vaporiser according to the second aspect, a liquid transport element according to the third aspect, or a cartomiser according to the fourth aspect.

According to a sixth aspect of some embodiments described herein, there is provided a vapour provision system comprising: a reservoir containing liquid; a vapour generator; and a wicking element arranged to transport liquid from the reservoir to the vapour generator for vaporisation to generate a vapour for user inhalation, the wicking element comprising a first section arranged to receive liquid from within the reservoir and a second section arranged to provide liquid to the vapour generator; wherein the first section of the wicking element comprises a flat surface compressed against a section of a wall of the reservoir around an opening in the wall through which the first section receives the liquid so the compressed portion of the wicking element forms a seal at least partially around the opening.

Furthermore, the approach described herein is not restricted to specific embodiments such as set out below, but includes and contemplates any appropriate combinations of features presented herein. For example, an aerosol source or a vapour provision system including an aerosol source may

be provided in accordance with approaches described herein which includes any one or more of the various features described below as appropriate.

Brief Description of the Drawings

Various embodiments of the invention will now be described in detail by way of example only with reference to the following drawings in which:

Figure 1 shows a cross-section through an example e-cigarette comprising a cartomiser and a control unit in which examples may be implemented;

Figure 2 shows a cross-sectional side view of a vapour-generating assembly including a reservoir, wick and heater;

Figure 3 shows a perspective view of an example atomiser;

Figure 4 shows a cross-sectional side view of a vapour-generating assembly including an atomiser such as the Figure 3 example;

Figure 5 shows a cross-sectional side view of part of another example vapour-generating assembly;

Figure 6 shows a plan view of a compression body comprised in an assembly such as that of Figure 4;

Figure 7 shows an plan view of an example wick;

Figure 8 shows a plan view of a further example wick;

Figure 9 shows a plan view of a still further example wick;

Figure 10 shows a plan view of part of a yet further example wick;

Figure 11 shows a cross-sectional side view of part of a further example vapour-generating assembly;

Figure 12 shows a plan view of a further example atomiser;

Figures 13A and 13B show cross-sectional side views of parts of further example vapour-generating assemblies; and

Figure 14 shows a cross-sectional side view of part of a wick indicating parameters of interest.

Detailed Description

Aspects and features of certain examples and embodiments are discussed / described herein. Some aspects and features of certain examples and embodiments may be implemented conventionally and these are not discussed / described in detail in the interests of brevity. It will thus be appreciated that aspects and features of apparatus and methods discussed herein which are not described in detail may be implemented in accordance with any conventional techniques for implementing such aspects and features.

As described above, the present disclosure relates to (but is not limited to) electronic aerosol or vapour provision systems, such as e-cigarettes. Throughout the following description the terms "e-cigarette" and "electronic cigarette" may sometimes be used;

however, it will be appreciated these terms may be used interchangeably with aerosol (vapour) provision system or device. The disclosure is also applicable to hybrid devices and systems configured to deliver nicotine or other substances by vaporising liquid and passing the vapour through a solid substrate such as tobacco. The various terms noted above should
5 be understood to include such devices. Similarly, "aerosol" may be used interchangeably with "vapour".

As used herein, the term "component" is used to refer to a part, section, unit, module, assembly or similar of an electronic cigarette that incorporates several smaller parts or elements, often within an exterior housing or wall. An electronic cigarette may be formed or
10 built from one or more such components, and the components may be removably connectable to one another, or may be permanently joined together during manufacture to define the whole electronic cigarette.

Figure 1 is a highly schematic diagram (not to scale) of an example aerosol/vapour provision system such as an e-cigarette 10. The e-cigarette 10 has a generally cylindrical
15 shape, extending along a longitudinal axis indicated by a dashed line, and comprises two main components, namely a control or power component or section 20 and a cartridge assembly or section 30 (sometimes referred to as a cartomiser, clearomiser or atomiser) that operates as a vapour-generating component.

The cartridge assembly 30 includes a reservoir 3 containing a source liquid
20 comprising a liquid formulation from which an aerosol is to be generated, for example containing nicotine. As an example, the source liquid may comprise around 1 to 3% nicotine and 50% glycerol, with the remainder comprising roughly equal measures of water and propylene glycol, and possibly also comprising other components, such as flavourings. Nicotine-free source liquid may also be used, such as to deliver flavouring. A solid substrate
25 (not illustrated) such as a portion of tobacco or other flavour element through which vapour generated from the liquid is passed, may also be included. The reservoir 3 has the form of a storage tank, being a container or receptacle in which source liquid can be stored such that the liquid is free to move and flow within the confines of the tank. Alternatively, the reservoir 3 may contain a quantity of absorbent material such as cotton wadding, glass fibre or porous
30 ceramic which holds the source liquid within a porous structure. The reservoir 3 may be sealed after filling during manufacture so as to be disposable after the source liquid is consumed, or may have an inlet port or other opening through which new source liquid can be added. The cartridge assembly 30 also comprises an electrical heating element or heater 4 located externally of the reservoir tank 3 for generating the aerosol by vaporisation of the
35 source liquid by heating. A liquid transfer arrangement (liquid transport element) such as a wick or other porous element 6 may be provided to deliver source liquid from the reservoir 3 to the heater 4. The wick 6 has one or more parts located inside the reservoir 3, or otherwise

in fluid communication with the liquid in the reservoir 3, so as to be able to absorb source liquid and transfer it by wicking or capillary action to other parts of the wick 6 that are in contact with the heater 4. This liquid is thereby heated and vaporised, to be replaced by new source liquid transferred to the heater 4 by the wick 6. The wick may be thought of as a
5 bridge, path or conduit between the reservoir 3 and the heater 4 that delivers or transfers liquid from the reservoir to the heater. Terms including conduit, liquid conduit, liquid transfer path, liquid delivery path, liquid transfer mechanism or element, and liquid delivery mechanism or element may all be used interchangeably herein to refer to a wick or corresponding component or structure.

10 A heater and wick (or similar) combination is sometimes referred to as an atomiser or atomiser assembly, and the reservoir with its source liquid plus the atomiser may be collectively referred to as an aerosol source. Other terminology may include a liquid delivery assembly, a liquid transfer assembly, or simply assembly, where in the present context these terms may be used interchangeably to refer to a vapour-generating element (vapour
15 generator) and a wicking or similar component or structure (liquid transport element) that delivers or transfers liquid from a reservoir to the vapour generator. Various designs are possible, in which the parts may be differently arranged compared with the highly schematic representation of Figure 1. For example, the wick 6 may be an entirely separate element from the heater 4, or the heater 4 may be configured to be porous and able to perform at
20 least part of the wicking function directly (a metallic mesh, for example). Other means for vapour generation may be used in place of a heater, such a vibrating vaporiser based on the piezoelectric effect, for example. In an electrical or electronic device, the vapour generator may be an electrical heating element that operates by ohmic (Joule) heating or by inductive heating. Also, the device may a non-electrical device, that operates by pump-action, for
25 example. In general, therefore, an atomiser can be considered to be a vapour-generating or vaporising element able to generate vapour from source liquid delivered to it, and a liquid transport element able to deliver or transport liquid from a reservoir or similar liquid store to the vapour generator by a wicking action / capillary force. Embodiments of the disclosure are applicable to all and any such assembly configurations. Regardless of the implementation,
30 the parts will be configured to form a liquid flow path by which the source liquid is able to travel from the interior of the reservoir 3 to the vicinity and surface of the heater 4 (or other vapour generator) for vaporisation. This is the intended fluid path, whereby liquid is delivered to the heater and should be successfully vaporised and thereby prevented from forming a leak by which liquid may escape into other locations inside or outside the electronic
35 cigarette. This operation is based on a delivery of source liquid at an expected rate such that the vapour generator can handle the incoming liquid. However, in the event of leakage such as may be caused by excess pressure inside the reservoir, or even under normal pressure

conditions when the vapour generator is not operating, too much liquid may accumulate in or at the wicking element and then drip away to escape as free liquid in a chamber housing the atomiser.

Returning to Figure 1, the cartridge assembly 30 also includes a mouthpiece 35
5 having an opening or air outlet through which a user may inhale the aerosol generated by the heater 4.

The power component 20 includes a cell or battery 5 (referred to herein after as a battery, and which may be re-chargeable) to provide power for electrical components of the e-cigarette 10, in particular the heater 4. Additionally, there is a printed circuit board 28
10 and/or other electronics or circuitry for generally controlling the e-cigarette. The control electronics/circuitry connect the heater 4 to the battery 5 when vapour is required, for example in response to a signal from an air pressure sensor or air flow sensor (not shown) that detects an inhalation on the system 10 during which air enters through one or more air inlets 26 in the wall of the power component 20. When the heating element 4 receives power
15 from the battery 5, the heating element 4 vaporises source liquid delivered from the reservoir 3 by the wick 6 to generate the aerosol, and this is then inhaled by a user through the opening in the mouthpiece 35. The aerosol is carried from the aerosol source to the mouthpiece 35 along an air channel (not shown) that connects the air inlet 26 to the aerosol source to the air outlet when a user inhales on the mouthpiece 35. An air flow path through
20 the electronic cigarette is hence defined, between the air inlet(s) (which may or may not be in the power component) to the atomiser and on to the air outlet at the mouthpiece. In use, the air flow direction along this air flow path is from the air inlet to the air outlet, so that the atomiser can be described as lying downstream of the air inlet and upstream of the air outlet.

In this particular example, the power section 20 and the cartridge assembly 30 are
25 separate parts detachable from one another by separation in a direction parallel to the longitudinal axis, as indicated by the solid arrows in Figure 1. The components 20, 30 are joined together when the device 10 is in use by cooperating engagement elements 21, 31 (for example, a screw or bayonet fitting) which provide mechanical and electrical connectivity between the power section 20 and the cartridge assembly 30. This is merely an example
30 arrangement, however, and the various components may be differently distributed between the power section 20 and the cartridge assembly section 30, and other components and elements may be included. The two sections may connect together end-to-end in a longitudinal configuration as in Figure 1, or in a different configuration such as a parallel, side-by-side arrangement. The system may or may not be generally cylindrical and/or have a
35 generally longitudinal shape. Either or both sections or components may be intended to be disposed of and replaced when exhausted (the reservoir is empty or the battery is flat, for example), or be intended for multiple uses enabled by actions such as refilling the reservoir

and recharging the battery. Alternatively, the e-cigarette 10 may be a unitary device (disposable or refillable/rechargeable) that cannot be separated into two parts, in which case all components are comprised within a single body or housing. Embodiments and examples of the present disclosure are applicable to any of these configurations and other configurations of which the skilled person will be aware.

The example device in Figure 1 is presented in a highly schematic format. Figure 2 shows a more detailed representation of an aerosol source indicating example positions of a tank, a heater and a wick.

Figure 2 shows a cross-sectional side view of an example aerosol source. A reservoir tank 3 has an outer wall 32 and an inner wall 34, each of which is generally tubular. The inner wall 34 is centrally disposed within the outer wall 32 to define an annular space between the two walls; this is the interior volume of the tank 3 intended to hold source liquid. The tank is closed at its lower end (in the orientation depicted) by a bottom wall 33 and at its top end by an upper wall 36. The central space encompassed by the inner wall 34 is a passage or channel 37 which at its lower end receives air drawn into the electronic cigarette (such as via air intakes 26 shown in Figure 1), and at its upper end delivers aerosol for inhalation (such as through the mouthpiece 35 in Figure 1). It also defines a chamber housing the atomiser.

Disposed within the airflow channel 37 is the atomiser 40 comprising a heater 4 and a wick 6. The wick, an elongate porous element that in this example is rod-shaped and may be formed from multiple fibres, is arranged across the airflow passage (shown as closer to the lower end of the tank 3, but it may be positioned higher) so that its ends pass through apertures in the inner wall 34 and reach into the interior volume of the tank 3 to absorb source liquid therein. The heater 4 is an electrically powered heating element in the form of a wire coil wrapped around the wick 6. Connecting leads 4a, 4b join the heater 4 to a circuit (not shown) for the provision of electrical power from a battery. The aerosol source will be disposed within the housing of a cartridge assembly section of an electronic cigarette, with a mouthpiece arranged at its top end and a controller and battery arranged at its lower end (possibly in a separable component). Note that the outer wall 32 of the tank 3 may or may not also be a wall of the cartridge assembly housing. If these walls are shared, the cartridge assembly may be intended to be disposable when the source liquid has been consumed, to be replaced by a new cartridge assembly connectable to an existing battery/power section, or may be configured so that the reservoir tank 3 can be refilled with source liquid. If the tank wall and the housing wall are different, the tank 3 or the whole aerosol source may be replaceable within the housing when the source liquid is consumed, or may be removable from the housing for the purpose of refilling. These are merely example arrangements and are not intended to be limiting.

In use, when the aerosol source within its assembly housing is joined to a battery section (separably or permanently depending on the e-cigarette design), and a user inhales through the mouthpiece, air drawn into the device through an inlet or inlets enters the airflow channel 37. The heater 4 is activated to produce heat; this causes source liquid brought to the heater 4 by the wick 6 to be heated to vaporisation. The vapour is carried by the flowing air further along the airflow channel 37 to the mouthpiece of the device to be inhaled by the user. The arrows A indicate the airflow and its direction along the air flow path through the device.

It will be appreciated that such an arrangement is potentially vulnerable to leaks. Leakage of the liquid directly from the reservoir 3 through the apertures by which the wick 6 enters the tank interior may occur. Also, if the wick absorbs more liquid than can be removed by the vaporisation action, this liquid may drip from the wick 6. In such ways, free liquid may arrive into the airflow channel 37, where it might be inhaled by the user together with the vapour, thereby spoiling the vaping experience, or might travel downwards to leak altogether out of the electronic cigarette, soiling the user or his possessions, or to contaminate other parts of the electronic cigarette such as the battery or the control electronics.

To address this, the present disclosure proposes an alternative arrangement for the wick (wicking element or liquid transport element). Instead of the wick having a portion or portions that reaches into the interior of the reservoir, the wick, formed from a porous material, is disposed externally to the reservoir, on the opposite side of the reservoir boundary wall to the source liquid held in the reservoir. An opening or aperture in the reservoir wall allows liquid to feed onto the wick, which is placed over the opening. A portion of the wick around the area which receives the liquid is placed in compression against the reservoir wall around the opening to provide a sealing effect. In this way, some containment of the liquid leaving the reservoir through the opening is provided.

Figure 3 shows a perspective view of an example atomiser (wick plus heater) in which the wick 6 is configured for use in this manner. In this example the wick 6, made from a porous material, is shaped as a planar element with a length and a width, and having a thickness t orthogonal to the plane of the wick. The wick 6 has a "dumbbell" or "dog bone" shape, in that it has a narrow central part 6a, and two enlarged end parts 6b which are wider in the plane of the wick than the central part 6a, with both the end parts 6b and the central part 6a having the same or similar thickness t (or at least that the thickness t is less than or much less than the length). The central part 6a has a heater 4 associated with it, which in this example is a wire heating coil comprising coils wrapped around the central part 6a of the wick 6. This portion of the atomiser will be disposed in the airflow channel of a vapour-generating component of an assembled electronic cigarette. Each of the end parts 6b is intended to receive liquid from a reservoir, specifically in the areas 6d marked as small

circles in Figure 3 which are towards the centre of each end part 6b. These liquid receiving areas 6d are placed over, across or against openings in the wall of a reservoir, so that liquid can flow out of the reservoir and onto the wick 6. Wicking or capillary action in the porous structure of the wick 6 conveys liquid from the liquid receiving areas 6d through the end parts 6b and into and along the central part 6a, to the vicinity of the heater 4 for vaporisation.

In addition, the end parts 6b of the wick 6 include compression regions 6c, shown in Figure 3 by shading. These are regions of the wick 6 which, when the wick is installed to receive liquid from openings in a reservoir, will be compressed against the wall of the reservoir generally around each opening. The compression is in the direction of the wick thickness t , substantially perpendicular to the plane of the wick. In the Figure 3 example, this arrangement is embodied by the perimeter of the end parts 6b being the compression regions 6c, and the liquid receiving areas 6d being at or near the centre of the end parts 6b, so that a compressed part 6c of the wick largely surrounds each liquid receiving area 6d. A gap in the compression region, so that the compression region 6c does not completely encircle or encompass the liquid receiving area 6d, is left where the central part 6a joins to the end part 6b to provide a liquid flow path from the liquid receiving area 6d to the heater 4 which does not include compressed wick material.

The compression of the wick material in its thickness direction has the effect of closing, or at least reducing the size of, the pores of the wick material in the compression regions. This reduces or removes the wicking and absorption capability of the wick material so that liquid flow is impeded. The compressed material forms a barrier or partial barrier to the movement of liquid within the wick. Liquid flow can thereby be directed as it is intended, namely towards the heater 4, and leakage in other directions can be reduced.

Figure 4 shows a cross-sectional schematic side view of the wick 6 of Figure 3 installed in association with a reservoir 3. The reservoir 3 is shaped similarly to that of Figure 2, in that it is annular with a central air flow passage 37 across which the wick 6 extends, the heater 4 being disposed in this passage 37. Note that only the lower part of the tank/reservoir 3 is shown; in reality it will be closed at its upper end as in Figure 2.

The reservoir has a lower, base wall 33 as before, and in this are provided two openings 42, which are oppositely arranged across the passage 37. The wick 6 is installed such that its end parts 6b overlay the base wall 33, with the liquid receiving areas 6d in line with the openings 42. The openings 42 are thereby covered by the end parts of the wick. Liquid can flow out of the reservoir 3 via the openings 42 and into the wick 6. Around each of the openings 42, the material of the wick in the compression regions 6c is compressed in the direction of the wick's thickness; this is represented by the arrows in Figure 4.

In this example, the compression of the wick is provided by a compression body 50 arranged on an opposite surface of the wick 6 to the base wall 33 of the reservoir 3. The

compression body 50 is positioned spaced apart from the base wall 33 to leave a cavity 48 in which the wick 6 is located. In the areas of the compression regions 6c of the wick 6, the compression body 50 is spaced apart from the base wall 33 by a distance less than the thickness t of the wick, so that the wick material is squeezed against the base wall 33 by the compression body 50. The compression body 50 might be formed integrally with the walls of the reservoir 3, for example by moulding or machining a plastics or metal material onto the reservoir wall(s), and the wick 6 then inserted into the cavity 48. Alternatively, the compression body 50 may be formed separately from the reservoir 3, so that the wick 6 is laid over the base wall 33 and the compression body 50 is then secured to the reservoir 3 at the appropriate spacing to form the cavity 48, or the wick 6 can be layered on the appropriate surface of the compression body 50 and the two parts secured at the proper spacing from the reservoir base wall 33. The compression body may be joined to the reservoir, as in Figure 4, or might be integral with a different component of the electronic cigarette so that it is correctly positioned to define the cavity 48 and create the required compression of the wick 6 when that component is assembled with the reservoir 3. In any case, the wick 6 may be inserted into the cavity 48 after the cavity is defined, or may be layered with the base wall 33 or the compression body 50 before the parts are assembled together.

Figure 4 shows the wick 6 positioned in the cavity 48 but does not illustrate any reduced thickness of the wick resulting from compression in the areas marked by the arrows. In reality, the compressed parts of the wick are made thinner than the uncompressed parts. This can be achieved by surface features on one or both of the compression body and the reservoir wall which protrude into the cavity over the area of the compression regions. The depth of the cavity is thus reduced where the surface features are located, and the wick material is squashed, squeezed or otherwise compressed between the surface features (if they are on both sides) or between a surface feature on one side and the base wall or the compression body on the other side.

Figure 5 shows a schematic cross-sectional view of part of a wick and reservoir, configured with protruding surface features to provide wick compression. In this example, both the base wall 33 of the reservoir 3 and the compression body 50 are provided with surface protrusions 52 facing inwardly into the cavity 48 formed between the base wall 33 and the compression body 50. The protrusions 52 are positioned opposite to each other across the cavity 48 and partially surround the opening 42 in the base wall 33, and are spaced somewhat from the opening 42 in this example (in other words, they are not immediately adjacent to the opening 42). The opposite protrusions 52 are separated by a distance less than the thickness t of the wick 6, so that the wick 6, when installed in the

cavity 48 across the opening 42, is compressed in its thickness direction in a region around the opening 42 by the protrusions 52.

Figure 6 shows plan view of the compression body 50 viewed in the direction of the arrows VI in Figure 5. The surface 50a which in use faces the base wall 33 of the reservoir 3 has formed in it two diametrically opposed recesses 54. These cooperate with the base wall to form the cavity for the wick 6. (Conversely, recesses might be provided in the base wall to cooperate with a flat compression body, or both parts might have recesses.) An arcuate protrusion 52 is formed inside each recess, aligned where the compression of the wick is required, namely almost but not completely surrounding the corresponding opening in the base wall. The positions of the wick 6 and the openings 42 in the base wall are shown in phantom.

A wick in accordance with the current disclosure is not limited to the Figure 3 example, and we may usefully describe a wick in more general terms to indicate the various parts included to implement a compression sealing functionality.

Figure 7 shows a plan view of an example wick 6 comprising various portions. This example again is planar and has a dumbbell shape in that plane. The enlarged parts at each end of the wick 6 each comprise a first portion 61 which is intended to be placed across an opening in a reservoir wall to receive liquid through that opening. The area of the first portion 61 for direct alignment with the opening comprises a liquid receiving area 6d, and in this example, the first portion 61 extends beyond the liquid receiving area 6d, the material of the first portion 61 receiving liquid from the liquid receiving area 6d by a wicking action. Hence the first portion has a larger area than the liquid receiving area 6d and the reservoir opening. Peripheral to each first portion 61 is a second portion 62 (shown by shading), which is located around an edge of the enlarged ends of the wick. The second portion 62 is the area of the wick 6 which is compressed when the wick is installed. The central narrow part of the wick 6, joining the two enlarged ends, is a third portion 63, which delivers liquid to a vapour-generating element such as a heater. In this example, the third portion 63 is directly contiguous with the first portions 61, via a gap in encircling arcs of the second portions 62 which otherwise surround the first portions 61. Liquid that enters the first portion 61 at the liquid receiving area 6d moves through the pores of the wick material in the first portion by capillary wicking to the third portion 63. In this way, liquid travels from the reservoir to the vapour-generating element. Liquid moving in other directions from the liquid receiving area 6d will be impeded by the compressed material of the second portion 62. Hence, the compression provides a sealing effect that inhibits or prevents movement of the liquid in directions other than towards the third portion and the associated vapour-generating element. The seal acts to direct the liquid in the first portion towards the vapour-generating

element, thereby promoting or enhancing movement of liquid in this direction. Leakage of liquid away from the vapour-generating element can thereby be reduced.

Use of the terms “first portion”, “second portion” and third portion” are not intended to be limiting, or to imply any particular physical or structural difference or separation between the various portions of the wick (although the wick might be made from a single piece of material or from separate pieces joined together). The terms are convenient labels to indicate parts of a wick that primarily perform particular functions, in other words, the receipt of liquid from the reservoir, the compression for sealing, and the provision of liquid to the vapour-generating element. In any wick, the various portions might be clearly distinct, or might blend or overlap with adjacent portions, if functions are shared. For example, the absorption of liquid at the reservoir opening, transport of liquid away from the opening and towards to the vapour-generating element, and delivery of liquid to the immediate vicinity of the vapour-generating region where it can be vaporised might be considered to all occur within a same portion of a wick, so that the first portion and the third portion can be considered to be the same, or coincident. The boundary between these various liquid movement operations might be indistinct, so that the first portion and the third portion overlap, or share material of the wick.

Other shapes and configurations of wick may be used. A plurality of double-ended shapes similar to the Figure 7 example may be used, where each end has a liquid receiving area. For example, the wick may be shaped, in its plane, as a bow-tie or as a dog-bone. Also, the two enlarged ends need not be the same shape or size. More complicated three- or four-ended shapes might be used, so as to receive liquid at more than two areas, from a reservoir with more than two openings in its wall.

Figure 8 shows a three-ended form of wick with round enlarged ends, and Figure 9 shows a four-ended wick in the form of a cross with triangular enlarged ends. Further ends might be added if desired. Such wicks might deliver liquid to vapour-generating elements comprising one or more heating coils, where the arms of the third portion 63 may or may not each be wrapped by a heating coil or part of a heating coil.

The second portion or portions of the wick, being the region which is compressed to form a seal, may be spaced apart from the liquid receiving area (so that the first region is larger than the liquid receiving area) as shown thus far, or may commence immediately adjacent to the liquid receiving area, so that the first region is the same shape and size as the reservoir wall opening.

Figure 10 shows one end of a wick configured in this way. A feature of such an arrangement is that there is no need for shaped protrusions on the reservoir base wall or the compression body. Instead, the two facing surfaces may be flat and act to provide the compression if the base wall and the compression body are spaced apart by less than the

thickness of the wick (so the depth of the cavity as a whole is less than the wick thickness). The wick end becomes compressed at all parts except for the liquid receiving area, where the presence of the opening in the reservoir wall provides no compression. Hence, the first portion of the wick is the same size and shape as the opening.

5 Figure 11 shows a cross-sectional side view of a wick installed in this way. Compression of the wick across all of the end by the facing surfaces of the reservoir end wall 33 and compression body 50 reduces the thickness of the wick more widely than in previous examples, and the wick bulges up into the opening 42 where it is not compressed, and also as it emerges from the cavity 48 into the airflow channel 37.

10 It will be noted in this example that the second portion 62 of the wick completely surrounds the first portion 61, and the third portion 63 is contiguous with the second portion 62 instead of contiguous with the first portion 61 as in the Figure 7 example. Appropriate choices of the wick material and the amount of compression can allow liquid to wick from the first portion 61 to the third portion 63 via the compressed second portion 62, particularly
15 owing to the uncompressed material in the third portion.

Further, the wick need not have an end which is enlarged in the plane of the wick compared to the width of the third portion associated with the vapour-generating element. The wick may instead have a substantially constant width along its end-to-end length. A heating coil might be wrapped around the third portion, but such a shape, which allows a
20 greater relative width for the third portion can also conveniently be used with other vapour-generating elements.

Figure 12 shows a schematic plan view of an example wick and heater assembly in which the wick 6 has a substantially constant width, and lacks enlarged ends. The heater 4 in this case is configured as an embedded heater, comprising a serpentine wire with many
25 loops embedded within the material of the wick 6 in the third portion 63.

A constant width wick with a relatively wide third portion might also be useful for delivery of liquid from a reservoir to a vapour-generating element in the form of a vibrating mesh.

30 In a further alternative, the wick may have a single-ended shape, comprising one first portion, one second portion peripheral to the first portion, and a third portion to convey liquid from the first portion to a vapour-generating element. This may be used with a reservoir having just one opening. Alternatively, the reservoir may have more than one opening, each delivering liquid to a different single-ended wick.

35 The reservoir need not be an annular shape surrounding a central airflow passage as in the Figure 4 example. Rather, the reservoir may be any convenient shape or size and bounded by an outer wall with one or more openings overlaid by a wick first portion. Also, a

single first portion of a wick may include more than one liquid receiving area if the first portion is located to overlay more than one opening in the reservoir wall.

Conveniently, the wick, in its uncompressed state, has a planar shape, meaning that its width and length are greater than its thickness, typically several or many times its thickness. A planar shape lends itself to a variety of shapes of wick, such as the examples described above, and offers a larger region over which the compression seal can extend in conjunction with a smaller dimension in the compression direction. This is not essential however, and a wick might have a non-planar shape in its uncompressed state. For example, an elongate rod shape such as a thick string or a bundle of fibres may have a sufficiently extensive width or diameter to allow compression to be effectively applied at one or both ends. The vapour-generating element might comprise a heating coil tightly wound to reduce the diameter in the third portion, or other heater or vapour-generating elements may be used.

Clearly, in the compression region, the wick is in contact with the wall of the reservoir. In arrangements where the first portion is larger than the opening, so that the second, compressed, portion is spaced apart from the edges of the opening, there is an expanse of the first, uncompressed, portion between the edges of the opening and the start of the compression region. If the cavity in which the wick is disposed is deeper than the thickness of the wick, there is the option of the wick surface being in contact with the reservoir wall in this expanse, or being spaced from the reservoir wall. Either alternative may be used, but contact between the uncompressed material and the reservoir wall can provide a capillary sealing effect. This may supplement the sealing provided by the compression of the wick in the compression region, so may be beneficial.

Figures 13A and 13B show a cross-sectional side view of wicks installed according to these two alternatives. In each case, the protruding portions 52 extending from the base wall 33 and the compression region 50 are placed so as to compress the very edges of the wick, in contrast to the Figure 5 example where the compression region 50 is located slightly inwardly from the wick edges. In Figure 13A, the wick 6 has the same thickness as the cavity 48 so that it is compressed by the protrusions 52 in the second portion, and has its upper surface touching the base wall 33 in the uncompressed first portion, around the opening 42. A capillary seal is formed over this area of uncompressed material of the first portion, contacting the base wall 33. In Figure 13B, the wick 6 has a thickness less than the depth of the cavity 48, but greater than the separation of the two opposing protrusions 52. Thus, the protrusions 52 compress the wick 6 in the second portion, but the upper surface of the wick is spaced from the base wall in the uncompressed first portion. A lesser or no capillary sealing effect is provided.

As noted, the compression of the wick comprises a squashing or squeezing of the wick material when the wick is in its installed location, that reduces the thickness of the wick at the position of the squeezing compared to the thickness of the wick when no compression is applied. The compression is applied along the thickness direction of the wick, which, regardless of wick shape, is a direction which will typically be substantially orthogonal or perpendicular to a plane in which liquid moves in the wick from the liquid receiving area in the first portion to the vapour-generating element associated with the third portion, or to a general direction of liquid flow from the liquid receiving area to the third portion. For a planar wick, having a thickness generally significantly less than the width and length, the compression is therefore orthogonal to the plane of the wick.

The amount of compression should be enough to produce a desired level of compression seal owing to the closed pores or reduced pore size in the porous wick material. This will depend on factors such as the type of wick material, the pore size and pore density (porosity), the thickness of the wick and the viscosity of the source liquid.

We can define the amount of compression in terms of the amount by which the wick thickness along the compression direction is reduced by the compression, compared to the uncompressed thickness. The compression may be applied from one side only or from both sides.

Figure 14 is a schematic side view depiction of part of a wick showing the parameters of interest. The uncompressed part of the wick has a thickness t , and the compressed part of the wick has a thickness T . Since the compression reduces the wick thickness, but will not reduce it to nothing, the compressed thickness T is always less than the uncompressed thickness t , so that $0 < T < t$, and $0 < T/t < 1$. Typically, the compression may reduce the thickness to a half or less of its uncompressed value, for example down to about one tenth of the uncompressed value. Therefore, $0.1 < T/t < 0.5$ in some examples. Other ranges for the T/t ratio are $0.1 < T/t < 0.4$; $0.1 < T/t < 0.3$; $0.1 < T/t < 0.2$; $0.2 < T/t < 0.5$; $0.2 < T/t < 0.4$; $0.2 < T/t < 0.3$; $0.3 < T/t < 0.5$ and $0.3 < T/t < 0.4$. Larger values for the T/t ratio are not excluded however, so that $0.1 < T/t < 0.6$; $0.1 < T/t < 0.7$; $0.1 < T/t < 0.8$ or $0.1 < T/t < 0.9$. Similarly, more significant compression might be employed, so that $0 < T/t < 0.1$.

As described thus far, the compression of the wick has been effected by squashing it between two opposing surfaces which are integral to the structure of the electronic cigarette. If the wick material is resilient or elastic, this compression is not permanent and the wick will revert to its original thickness if removed from its location overlying the reservoir opening. However, other methods of compression may also be used if preferred. For example, techniques that give a permanent, irreversible reduction in the wick thickness may be used.

Adhesive might be applied to the wick material in the second portion of the wick and/or to the reservoir wall around the opening, and the wick placed in position across the

opening. Before the adhesive dries, compression is applied to the second portion for example by pressing a specially shaped tool that matches the shape of the second portion into the wick material, to close up the pore structure. If the adhesive penetrates the porous structure under this pressure, when the adhesive dries (perhaps by curing under the action
5 of ultraviolet light or similar), the wick will be stuck in place against the reservoir wall in the second portion, and the pore structure in the second portion will be retained in the compressed state. There is no particular requirement for a compression body in this arrangement, although a surface on the opposite face of the wick from the reservoir wall may be useful in containing any leaked liquid.

10 Depending on the material used for the wick, a similar result may be achieved by the application of energy to soften or melt the material of the wick in the second portion, either during or immediately before compression of the second portion so that the material becomes fused into a compressed state. If the reservoir wall is made from a suitable material such as a plastics material, the wick may be fused to the wall in the same
15 procedure. Heat might be applied by application of a heated tool pressed against the second portion of the wick when the wick has been positioned over the opening, for example. A laser beam might be directed onto the wick material to provide the required energy to melt the wick material, and application of a tool could then be used to compress the softened material of the second portion.

20 A variety of porous materials may be used for a wick according to the present disclosure. The material should have an appropriate porosity to provide the required wicking rate (liquid delivery rate) for the source liquid or liquids with which it is envisaged to be used, and be compressible by an amount that provides a useful amount of sealing. The material is therefore compliant, soft, flexible and/or non-rigid. For a planar wick, any such material that
25 can be formed into a sheet or mat may be used. The sheet might have the form of a fabric, being either woven or non-woven. For example, the sheet could be formed from fibres comprising natural materials such as cotton, wool, cellulose or linen, or from artificial materials such as various polymers and plastics. Ceramics and glass fibres may also be used. Also, the sheet could comprise a foamed or sponge material (include natural and man-
30 made sponges). The wick shape may be cut or stamped from a larger sheet of the wick material. As noted, the wick need not have a planar form, so that ropes, strings or bundles of fibres might be used. Two or more materials might be included in a single wick, for example by combining or mixing fibres of different materials or composition.

35 In conclusion, in order to address various issues and advance the art, this disclosure shows by way of illustration various embodiments in which the claimed invention(s) may be practiced. The advantages and features of the disclosure are of a representative sample of embodiments only, and are not exhaustive and/or exclusive. They are presented only to

assist in understanding and to teach the claimed invention(s). It is to be understood that advantages, embodiments, examples, functions, features, structures, and/or other aspects of the disclosure are not to be considered limitations on the disclosure as defined by the claims or limitations on equivalents to the claims, and that other embodiments may be utilised and
5 modifications may be made without departing from the scope of the claims. Various embodiments may suitably comprise, consist of, or consist essentially of, various combinations of the disclosed elements, components, features, parts, steps, means, etc. other than those specifically described herein. The disclosure may include other inventions not presently claimed, but which may be claimed in future.

Claims

1. An aerosol source for a vapour provision system comprising:
 - a vapour-generating element;
 - a reservoir for holding source liquid, the reservoir being bounded by a wall having an opening therein; and
 - a liquid transport element comprising a first portion arranged to receive liquid from the reservoir via the opening, a second portion peripheral to the first portion, and a third portion arranged to deliver liquid from the first portion to the vapour-generating element, the liquid transport element being planar and having a thickness orthogonal to the plane of the liquid transport element and to a direction of liquid flow from the first portion to the third portion;
 - wherein at least part of the second portion is compressed along a direction of the thickness and orthogonal to the plane of the liquid transport element against a section of the wall around the opening, in use, to provide a sealing effect around at least part of the first portion to promote movement of liquid towards the vapour-generating element.
2. The aerosol source according to claim 1, in which the liquid transport element has a thickness t , and the second portion is compressed in the direction of the thickness t to a compressed thickness T less than the thickness t .
3. The aerosol source according to claim 2, in which the second portion is compressed such that $0.1 < T/t < 0.5$.
4. The aerosol source according to any one of claims 1 to 3, comprising a compression body providing a surface facing a surface of the wall of the reservoir, the two surfaces spaced apart to define a cavity in which the liquid transport element is accommodated.
5. The aerosol source according to claim 4, in which at least part of the two surfaces are spaced apart to define the cavity with a depth which is less than a thickness of the liquid transport element so as to compress the second portion when the liquid transport element is accommodated in the cavity.
6. The aerosol source according to claim 5, in which one or both of the two surfaces has a protrusion extending into the cavity to locally reduce the depth of the cavity to less than the thickness of the liquid transport element.

7. The aerosol source according to any one of claims 1 to 6, in which the first portion extends beyond the opening in the wall of the reservoir such that the second portion is spaced apart from a perimeter of the opening.
8. The aerosol source according to claim 7, in which at least part of the first portion is in contact with a surface of the wall around the opening to provide a capillary sealing effect.
9. The aerosol source according to any one of claims 1 to 8, in which the first portion is the same as the third portion, coincident with the third portion, overlaps with the third portion or is contiguous with the third portion.
10. The aerosol source according to any one of claims 1 to 9, in which the liquid transport element has a width and a length in the plane orthogonal to the direction of compression of the second portion, and the thickness is less than the length.
11. The aerosol source according to claim 10, in which the thickness of the liquid transport element in the direction of compression of the second portion is less than the width of the liquid transport element.
12. The aerosol source according to claim 10 or claim 11, in which the liquid transport element has an end part including the first portion and the second portion, the end part having a width which is greater than a width of the third portion.
13. The aerosol source according to any one of claims 1 to 9 and 11 to 12, in which the liquid transport element has a length in the plane orthogonal to the direction of compression of the second portion, and has two end parts each including the first portion and the second portion, the end parts being arranged on either side of the third portion along the length of the liquid transport element.
14. The aerosol source according to claim 13, in which the reservoir has an annular shape bounded by the wall comprising an end wall having two openings oppositely disposed across a diameter of the annular shape, and the liquid transport element being arranged such that each of the said first portions receives liquid via one of the two openings, and each of the said second portions is compressed against a section of the end wall around one of the two openings.
15. A vaporiser for a vapour provision system comprising:

a vapour-generating element for generating vapour from a liquid; and

a liquid transport element comprising a first portion configured to receive liquid from a reservoir via an opening in a wall of the reservoir, a second portion peripheral to the first portion and configured for compression against a section of wall around the opening, and a third portion configured to deliver liquid from the first portion to the vapour-generating element,

wherein the liquid transport element is planar and has a thickness orthogonal to the plane of the liquid transport element and to a direction of liquid flow from the first portion to the third portion, and wherein the second portion is configured for compression along a direction of the thickness and orthogonal to the plane of the liquid transport element.

16. A liquid transport element for a vapour provision system comprising:

a first portion configured to receive liquid from a reservoir via an opening in a wall of the reservoir,

a second portion peripheral to the first portion and configured for compression against a section of wall around the opening; and

a third portion configured to deliver liquid from the first portion to a vapour generating element configured to generate vapour from the liquid

wherein the liquid transport element is planar and has a thickness orthogonal to the plane of the liquid transport element and to a direction of liquid flow from the first portion to the third portion, and wherein the second portion is configured for compression along a direction of the thickness and orthogonal to the plane of the liquid transport element.

17. A cartomiser for a vapour provision system comprising the aerosol source according to any one of claims 1 to 14, the vaporiser according to claim 15, or the liquid transport element according to claim 16.

18. A vapour provision system comprising the aerosol source according to any one of claims 1 to 14, the vaporiser according to claim 15, the liquid transport element according to claim 16, or the cartomiser according to claim 17.

19. A vapour provision system comprising:

a reservoir containing liquid;

a vapour generator; and

a wicking element arranged to transport liquid from the reservoir to the vapour generator for vaporisation to generate a vapour for user inhalation, the wicking element

comprising a first section arranged to receive liquid from within the reservoir and a second section arranged to provide liquid to the vapour generator;

wherein the first section of the wicking element comprises a flat surface compressed against a section of a wall of the reservoir around an opening in the wall through which the first section receives the liquid, in use, so the compressed portion of the wicking element forms a seal at least partially around the opening;

wherein the wicking element is planar and has a thickness orthogonal to the plane of the wicking element and to a direction of liquid flow from the first portion to the second portion, and the flat surface is compressed along a direction of the thickness and orthogonal to the plane of the wicking element.

1/4

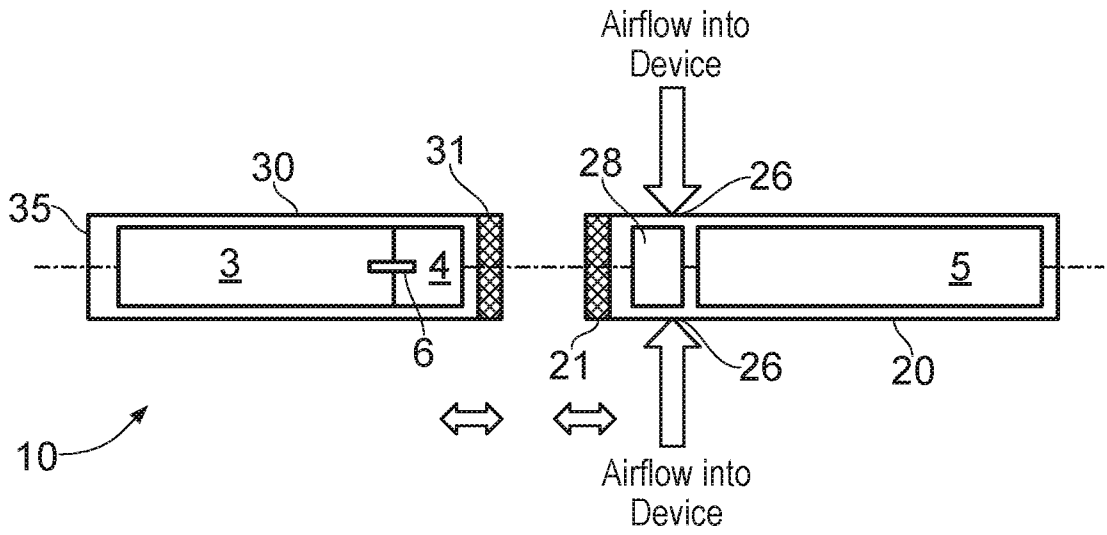

FIG. 1

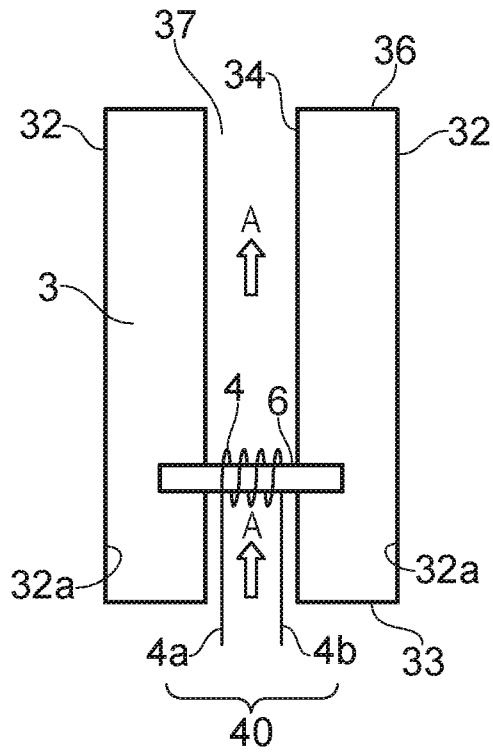

FIG. 2

2/4

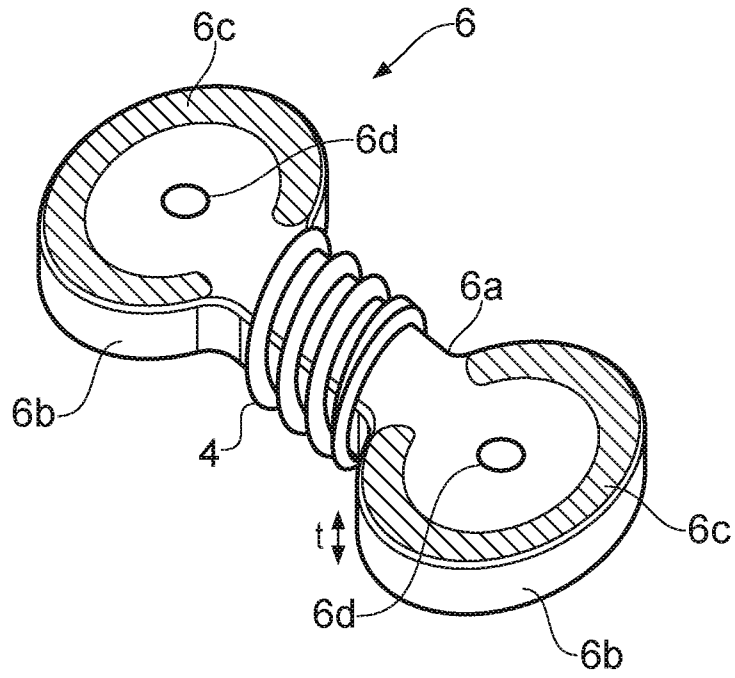

FIG. 3

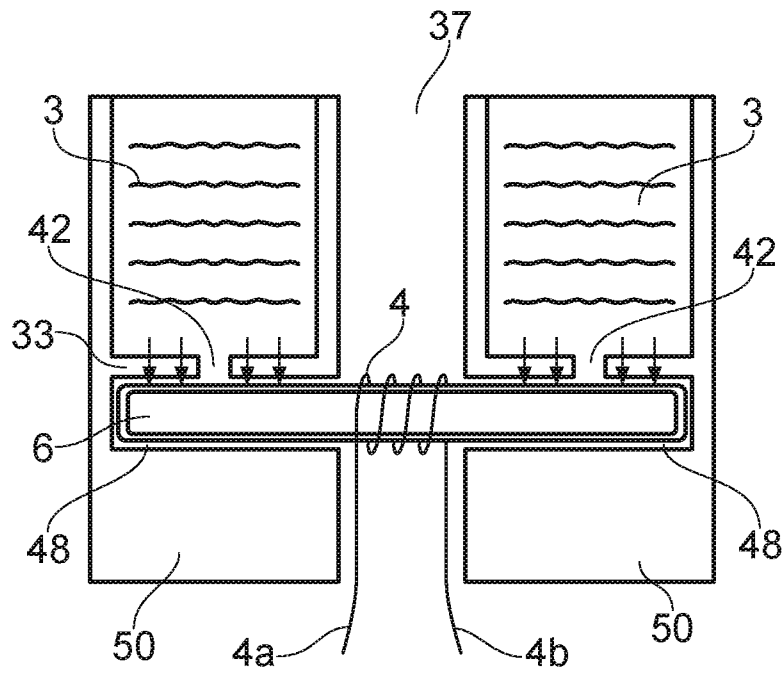

FIG. 4

3/4

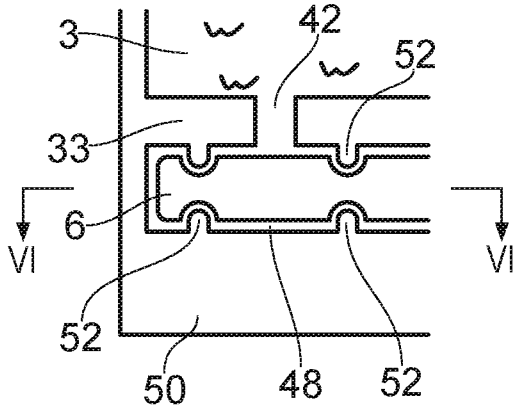

FIG. 5

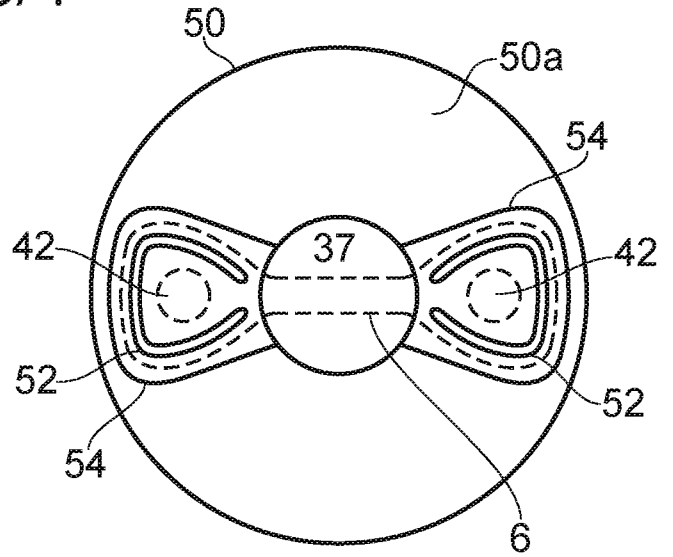

FIG. 6

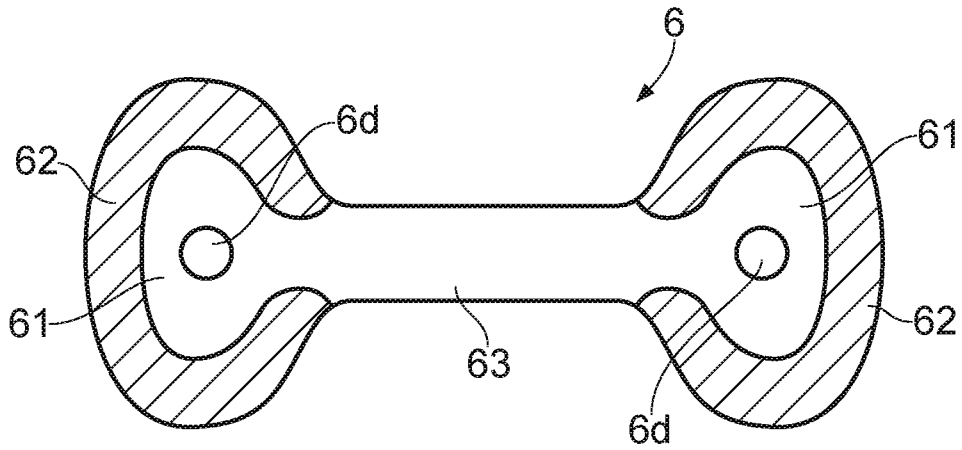

FIG. 7

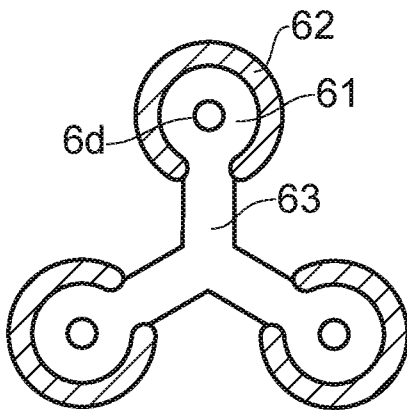

FIG. 8

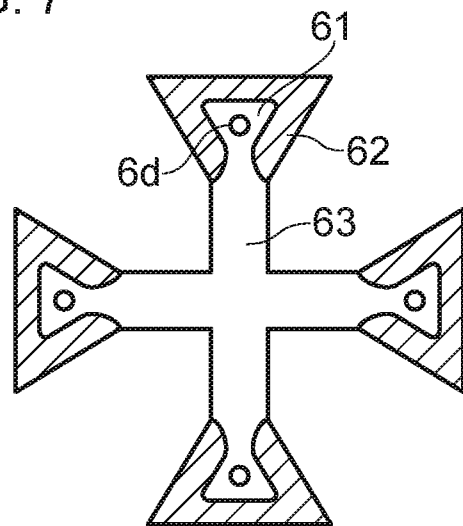

FIG. 9

4/4

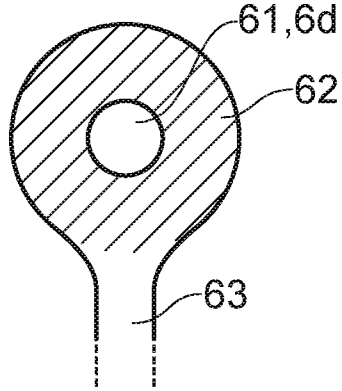

FIG. 10

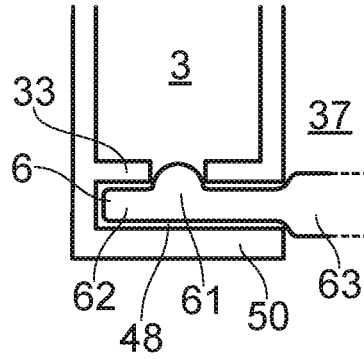

FIG. 11

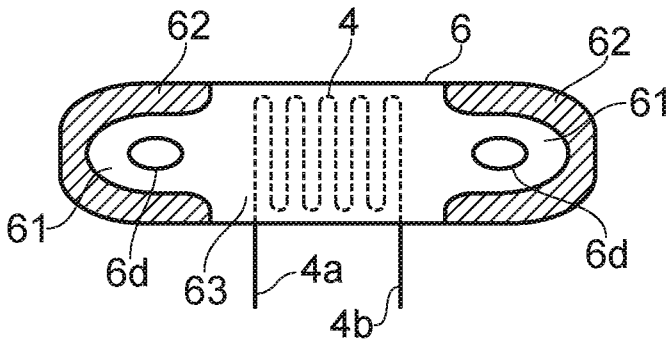

FIG. 12

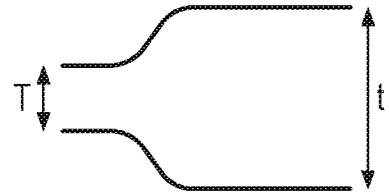

FIG. 14

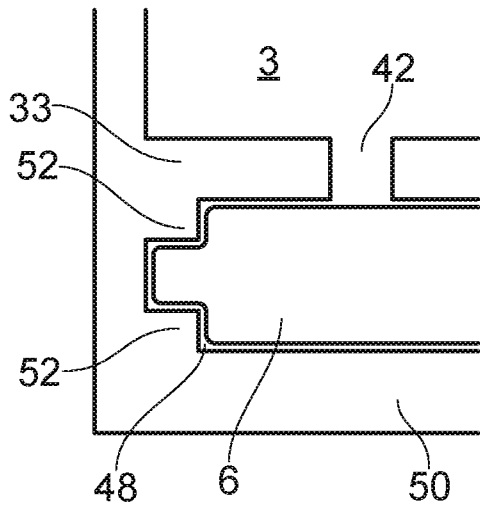

FIG. 13A

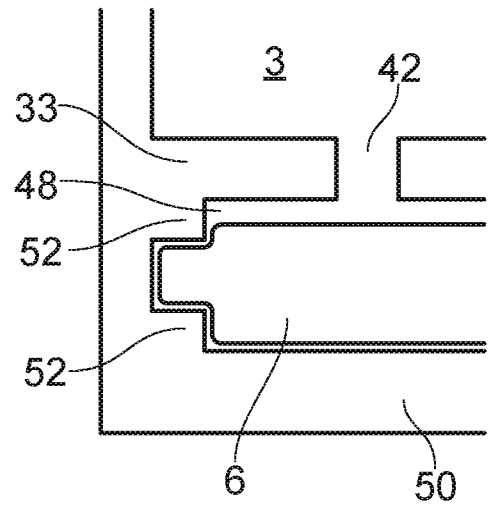

FIG. 13B

