

(No Model.)

C. E. BEAM.  
GLASS MOLD.

No. 442,599.

Patented Dec. 16, 1890.

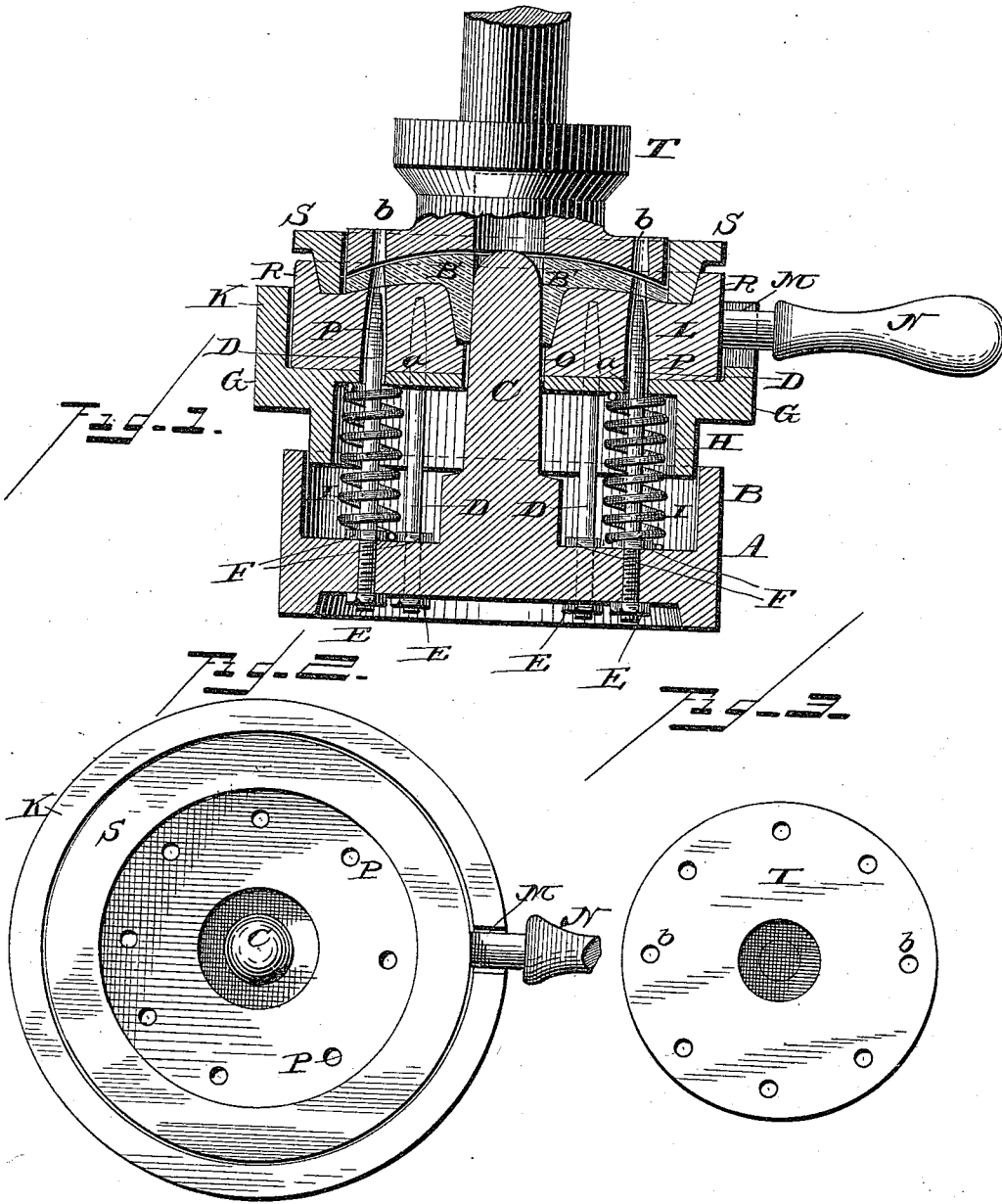

WITNESSES  
*H. L. Curant.*  
*H. M. Sterling*

INVENTOR  
*Chas. E. Beam*  
By  
*S. M. J. S. S. S.*  
Attorney

# UNITED STATES PATENT OFFICE.

CHARLES E. BEAM, OF FOSTORIA, OHIO.

## GLASS-MOLD.

SPECIFICATION forming part of Letters Patent No. 442,599, dated December 16, 1890.

Application filed April 8, 1890. Serial No. 347,154. (No model.)

*To all whom it may concern:*

Be it known that I, CHARLES E. BEAM, a citizen of the United States, residing at Fostoria, in the county of Seneca and State of Ohio, have invented new and useful Improvements in Glass-Molds; and I do hereby declare the following to be a full, clear, and exact description of said invention, reference being had to the accompanying drawings, and to the letters of reference marked thereon, which form a part of this specification.

My invention relates to improvements in molds for the manufacture of glass.

The object of my invention is to provide a mold by which bobèche for chandeliers, candelabras, and other like articles of glass are formed, and perforated with small holes for the purpose of receiving wires by which the prisms are suspended therefrom.

Referring to the drawings, Figure 1 is a vertical sectional view of the mold with the article therein. Fig. 2 is a top or plan view of the mold with the plunger removed. Fig. 3 is a top or plan view of the plunger.

A indicates the bottom of the mold, having an upwardly-extended annular ring B and an upwardly-extended central portion C for making a central hole in the article. The bottom A is provided with a series of spuds or spikes D, which are held in place by the nuts E and F.

G is a slip-sleeve, which is provided with an annular ring or projection H on the lower side and adapted to fit within the annular ring B of the base or bottom of the mold. The bottom of the sleeve is also provided with holes *a*, through which the spuds or spikes D project, two or more of said spuds or spikes being surrounded with spiral springs I, which serve to hold the slip-sleeve G in an elevated position.

The slip-sleeve G is provided with an upwardly-extended annular flange K, adapted to receive the main body L of the mold, the flange K being provided with a notch M to receive the handle N of the main body of the mold.

The main body of the mold L is provided with a central aperture O, through which the projecting portion C of the base extends to form a central aperture in the article, and also with a series of openings P, through which the spuds or spikes D project.

The main body of the mold is provided with an annular upwardly-projecting flange R, adapted to receive the annular ring S.

T is a plunger, the lower portion of which is provided with apertures *b* and adapted to fit within the ring S. The apertures *b* in the plunger T are so arranged as to receive the upper ends of the spuds or spikes D, so that apertures will be formed in the article at any desired point.

B' indicates the article within the mold after the pressing operation has been completed, and in this instance is a "bobèche" for use in candelabras; but I do not wish to limit myself to the manufacture of this particular class of goods, as it is obvious that other articles of glass requiring small perforations may be made in like manner.

What I claim, and desire to secure by Letters Patent, is—

1. A mold for pressing glass articles with small apertures therein, a base having spikes or spuds projecting upward through the other portions of the mold, and a plunger-head, said spuds or spikes being surrounded with spiral springs to elevate the upper portions of the mold after the pressure has been withdrawn, as set forth.

2. In a mold for pressing glassware, a base portion provided with spuds or spikes and an upwardly-projecting annular flange B, adapted to receive the slip-sleeve G, said slip-sleeve being also provided with a cavity in its upper portion to receive the main body of the mold, a ring adapted to fit on the main body, and a plunger adapted to work within said ring.

3. In a mold for pressing perforated glass articles, a base having a central projection C, and a series of spikes or spuds D, all of which project upward through the other portions of the mold, being normally held in an elevated position by suitable springs located in the base, as set forth.

In testimony whereof I affix my signature in the presence of two subscribing witnesses.

CHARLES E. BEAM.

Witnesses:

W. S. BRADY,  
OTTO JAEGER.