

(19) World Intellectual Property Organization
International Bureau



(10) International Publication Number
WO 2009/100108 A1

(43) International Publication Date
13 August 2009 (13.08.2009)

- (51) International Patent Classification:
G11C 8/14 (2006.01) G11C 7/10 (2006.01)
G11C 7/18 (2006.01)
- (21) International Application Number:
PCT/US2009/033040
- (22) International Filing Date:
4 February 2009 (04.02.2009)
- (25) Filing Language: English
- (26) Publication Language: English
- (30) Priority Data:
61/026,220 5 February 2008 (05.02.2008) US
12/364,055 2 February 2009 (02.02.2009) US
- (63) Related by continuation (CON) or continuation-in-part (CIP) to earlier application:
US 12/364,055 (CON)
Filed on 2 February 2009 (02.02.2009)
- (71) Applicant (for all designated States except US): **MARVELL WORLD TRADE LTD.** [BB/BB]; L'Horizon Gunsite Road, Brittons Hill, St. Michael, BB 14027 (BB).
- (72) Inventors; and
- (75) Inventors/Applicants (for US only): **SUTARDJA, Pantas** [US/US]; 18690 Blythswood Drive, Los Gatos, Cali-

fornia 95030 (US). **LEE, Winston** [US/US]; 3880 Duncan Place, Palo Alto, California 94306 (US).

- (74) Agents: **WIGGINS, Michael D.** et al.; Harness, Dickey & Pierce, P.L.C., P.O. Box 828, Bloomfield Hills, Michigan 48303 (US).
- (81) Designated States (unless otherwise indicated, for every kind of national protection available): AE, AG, AL, AM, AO, AT, AU, AZ, BA, BB, BG, BH, BR, BW, BY, BZ, CA, CH, CN, CO, CR, CU, CZ, DE, DK, DM, DO, DZ, EC, EE, EG, ES, FI, GB, GD, GE, GH, GM, GT, HN, HR, HU, ID, IL, IN, IS, JP, KE, KG, KM, KN, KP, KR, KZ, LA, LC, LK, LR, LS, LT, LU, LY, MA, MD, ME, MG, MK, MN, MW, MX, MY, MZ, NA, NG, NI, NO, NZ, PG, PH, PL, PT, RO, RS, RU, SC, SD, SE, SG, SK, SL, SM, ST, SV, SY, TJ, TM, TN, TR, TT, TZ, UA, UG, US, UZ, VC, VN, ZA, ZM, ZW.
- (84) Designated States (unless otherwise indicated, for every kind of regional protection available): ARIPO (BW, GH, GM, KE, LS, MW, MZ, NA, SD, SL, SZ, TZ, UG, ZM, ZW), Eurasian (AM, AZ, BY, KG, KZ, MD, RU, TJ, TM), European (AT, BE, BG, CH, CY, CZ, DE, DK, EE, ES, FI, FR, GB, GR, HR, HU, IE, IS, IT, LT, LU, LV, MC, MK, MT, NL, NO, PL, PT, RO, SE, SI, SK, TR), OAPI (BF, BJ, CF, CG, CI, CM, GA, GN, GQ, GW, ML, MR, NE, SN, TD, TG).

[Continued on next page]

(54) Title: SYSTEM AND METHOD FOR DECODING A MEMORY ARRAY COMPRISING BLOCKS AND SUB-BLOCKS

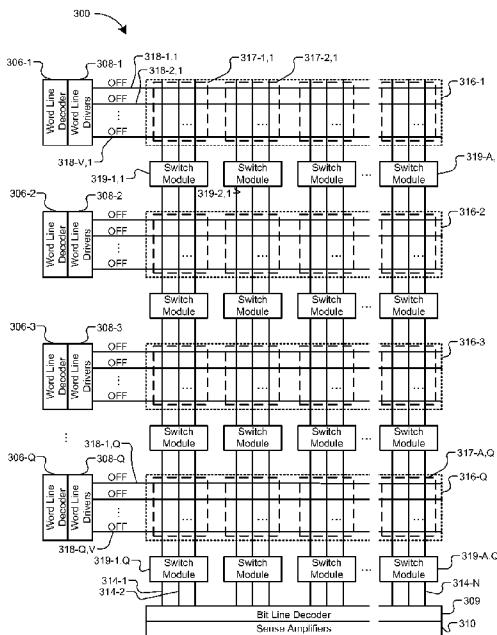

FIG. 6A

(57) Abstract: A memory system includes Q memory blocks (216) that each include M memory sub-blocks (224). The memory system also includes Q word line decoders (206) that each are associated with a different one of the Q memory blocks (216). The memory system also includes a bit line decoder (309) and Q x M switch modules (319). Each Q x M switch module selectively controls access to one of the M memory sub-blocks of the Q memory blocks. The Q word line decoders and the bit line decoder access less than M memory sub-blocks in at least two of the Q memory blocks during one of a read and write operation. M and Q are integers greater than 1.

WO 2009/100108 A1

Published:

— with international search report (Art. 21(3))

— with amended claims (Art. 19(1))

SYSTEM AND METHOD FOR DECODING A MEMORY ARRAY COMPRISING BLOCKS AND SUB-BLOCKS

CROSS-REFERENCE TO RELATED APPLICATIONS

[0001] This application claims priority to U.S. Application No. 12/364,055, filed February 2, 2009, and, U.S. Provisional Application No. 5 61/026,220, filed February 5, 2008. The disclosures of the above applications are incorporated herein by reference in its entirety.

FIELD

[0002] The present disclosure relates to memory systems, and more particularly to writing data to memory and reading data stored in memory.

10

BACKGROUND

[0003] The background description provided herein is for the purpose of generally presenting the context of the disclosure. Work of the presently named inventors, to the extent the work is described in this background section, as well as aspects of the description that may not otherwise qualify as prior art at 15 the time of filing, are neither expressly nor impliedly admitted as prior art against the present disclosure.

[0004] Memory devices include an array of memory cells that store information. Memory devices may be volatile or non-volatile. Non-volatile memory devices can retain stored information even when not powered, whereas 20 volatile memory devices typically do not retain stored information when not powered. Examples of memory devices include read-only memory (ROM), random access memory (RAM) and flash memory.

[0005] FIG. 1 illustrates a conventional memory system 100. The memory system 100 includes an array 102 of memory cells 104-1,1, 104-1,2 ..., 25 and 104-M,N (referred to herein as memory cells 104), a word line decoder 106, word line drivers 108, a bit line decoder 109, and sense amplifiers 110. The word line decoder 106 may select one of M rows of memory cells 104 for reading and writing operations via word lines 112-1, 112-2, ..., and 112-M (referred to herein as word lines 112). The word line drivers 108 may apply a voltage to the 30 selected word line 112 to activate the memory cells 104 in communication with

the selected word line 112. The sense amplifiers 110 may detect the presence or absence of data stored in the memory cells 104 via global bit lines 114-1, 114-2, ..., and 114-N (referred to herein as global bit lines 114). The bit line decoder 109 may select one of N columns of memory cells 104 for reading and writing operations via the global bit lines 114.

[0006] Each of the memory cells 104 may include diodes 105-1,1, 105-1,2..., and 105-M,N (referred to herein as diodes 105) and a data storage element 107-1,1, ..., and 107-M,N (referred to herein as data storage element 107). Alternatively, each of the memory cells 104 may include transistors (not shown) and a data storage element 107. Each diode 105 may communicate with a corresponding word line 112 and a corresponding data storage element 107. Other configurations are possible for the memory cells 104.

[0007] Referring now to FIGs. 2A-2B, the array 102 of memory cells 104 may be arranged in blocks 116-1, 116-2, ..., and 116-Q (referred to herein as blocks 116). A block 116 may include local word lines 118-1,1, 118-2,1, ..., and 118-V,Q (referred to herein as local word lines 118) and local bit lines 120-1,1,1, 120-2,1,1, ..., and 120-W,L,Q (referred to herein as local bit lines 120). Memory cells 104 may be formed at the intersection of the local word lines 118 and the local bit lines 120. The local word lines 118 may communicate with respective word line decoders 106-1, 106-2, ..., and 106-Q (referred to herein as word line decoders 106) and word line drivers 108-1, 108-2, ..., and 108-Q (referred to herein as word line drivers 108).

[0008] The local bit lines 120 may be arranged in groups. A group of local bit lines 120 may communicate with multiplexers 122-1,1, 122-2,1, ..., and 122-L,Q (referred to herein as multiplexers 122). Each multiplexer 122 may include a control input 123 that selectively controls which input to the multiplexer will be output from the multiplexer. A read/write (R/W) control module (not shown) may provide the control inputs. A block 116 may communicate with L multiplexers 122, which may select respective local bit lines 120 for reading and writing operations. The multiplexers 122 may communicate with respective global bit lines 114. The global bit lines 114 may communicate with each block

116 in the memory array 102. Bit line decoders 109 and sense amplifiers 110 (shown in FIG. 1) may communicate with the global bit lines 114.

[0009] The memory system 100 may include a read/write (R/W) control module (mentioned above). The R/W control module may control R/W operations of the memory cells 104 via the word line decoder 106, the word line drivers 108, the bit line decoder 109, and the sense amplifiers 110. The R/W control module may execute a read cycle to access data stored in one or more data storage elements 107 of the memory cells 104. The R/W control module may also execute a write cycle to store data in one or more data storage elements 107 of the memory cells 104. During each read and write cycle, the R/W control module may access a given memory cell 104 by applying a voltage to a local word line 118 of a block 116 in the memory array 102. During a read cycle, the sense amplifiers 110 may detect the presence or absence of data in a given data storage element 107 of a memory cell 104 in communication with a local word line 118. During a write cycle, the bit line decoders 109 may select a given memory cell 104 for storing data.

[0010] For example, as shown in FIG. 2B, local word line 118-1,Q is active. In other words, the word line driver 108-Q may apply a voltage to local word line 118-1,Q. Multiplexers 122-1,Q, 122-2,Q ..., and 122-L,Q may select local bit lines 120-1,1,Q, 120-1,2,Q ..., and 120-1,L,Q for reading and writing operations. Thus, memory cells 104-1,1, 104-1,2, ..., and 104-1,L may be conducting. To read data, the sense amplifiers 110 may detect the presence or absence of data in the memory cells 104 in communication with the selected local word line 118 and the selected local bit lines 120. In the configuration shown in FIG. 2B, L memory cells 104 may be read during a read cycle. To write data, the bit line decoder 109 may select memory cells 104 for storing data via global bit lines 114 and multiplexers 122.

SUMMARY

[0011] A memory system includes Q memory blocks that each include M memory sub-blocks. The memory system also includes Q word line decoders that each are associated with a different one of the Q memory blocks. The memory system also includes a bit line decoder and Q x M switch modules.

Each $Q \times M$ switch module selectively controls access to one of the M memory sub-blocks of the Q memory blocks. The Q word line decoders and the bit line decoder access less than M memory sub-blocks in at least two of the Q memory blocks during one of a read and write operation. M and Q are integers greater than 1.

[0012] In other features, a memory system includes a memory array. The memory array includes a plurality of bit lines, a plurality of word lines and a plurality of memory cells. Each memory cell is formed at a corresponding intersection of a bit line and a word line in the memory array. The memory system also includes a read/write module to control activation of at least two memory cells in the memory array during a read operation or a write operation. The at least two memory cells activated by the read/write control module are located on a different word line and a different bit line in the memory array.

[0013] In other features, a method for accessing memory includes selectively controlling access to one of M memory sub-blocks of Q memory blocks by selectively controlling each of $Q \times M$ switch modules. The method also includes accessing less than M memory sub-blocks in at least two of the Q memory blocks by activating a bit line and word lines associated with the at least two of the Q memory blocks during one of a read and write operation. M and Q are integers greater than 1.

[0014] In other features, a method includes forming a plurality of memory cells at a corresponding intersection of a bit line and a word line in a memory array. The method also includes controlling activation of at least two memory cells in the memory array during a read operation or a write operation. The at least two memory cells are located on a different word line and a different bit line in the memory array.

[0015] Further areas of applicability of the present disclosure will become apparent from the detailed description, the claims and the drawings. It should be understood that the detailed description and specific examples are intended for purposes of illustration only and are not intended to limit the scope of the disclosure.

BRIEF DESCRIPTION OF DRAWINGS

[0016] The present disclosure will become more fully understood from the detailed description and the accompanying drawings, wherein:

[0017] FIG. 1 is a schematic representation of a memory system according to the prior art;

[0018] FIG. 2A is a schematic representation of a memory system according to the prior art;

[0019] FIG. 2B is a schematic representation of a memory system according to the prior art;

[0020] FIG. 3 is a block diagram of a memory system according to the present disclosure;

[0021] FIG. 4 is a schematic representation of a memory system according to the present disclosure;

[0022] FIG. 5A is a schematic representation of a portion of a memory system according to the present disclosure;

[0023] FIG. 5B is a schematic representation of a portion of a memory system according to the present disclosure;

[0024] FIG. 6A is a schematic representation of a portion of a memory system according to the present disclosure;

[0025] FIG. 6B is a schematic representation of a switch module according to the present disclosure;

[0026] FIG. 6C is a schematic representation of a portion of a memory system according to the present disclosure; and

[0027] FIG. 7 is a schematic representation of a portion of a memory system according to the present disclosure.

DESCRIPTION

[0028] The following description is merely exemplary in nature and is in no way intended to limit the disclosure, its application, or uses. For purposes of clarity, the same reference numbers will be used in the drawings to identify similar elements. As used herein, the phrase at least one of A, B, and C should be construed to mean a logical (A or B or C), using a non-exclusive logical or. It

should be understood that steps within a method may be executed in different order without altering the principles of the present disclosure.

[0029] As used herein, the term module refers to an Application Specific Integrated Circuit (ASIC), an electronic circuit, a processor (shared, 5 dedicated, or group) and memory that execute one or more software or firmware programs, a combinational logic circuit, and/or other suitable components that provide the described functionality.

[0030] Memory cells may be arranged in arrays of rows and columns of word lines and bit lines, respectively. Capacitive and/or leakage current may 10 cause a voltage drop along a selected word line due to distributed resistance along the word line. The voltage drop may cause voltage conditions of memory cells along the word line to vary. Thus, the voltage required to activate memory cells may vary from memory cell to memory cell. The voltage drop may be significant where a large number of memory cells along a selected word line are 15 activated during a read and/or write operation.

[0031] The voltage drop along the word line (V_{WL}) may be determined according to the following equation:

$$V_{WL} = (Y \times I_C) \times R_{WL} ,$$

where Y is the number of activated memory cells in communication with a 20 selected word line, I_C is the capacitive and/or leakage current of each memory cell, and R_{WL} is the distributed resistance of the selected word line. For example, if I_C is $100\mu A$, N is 1000 and R_{WL} is 100Ω , the voltage drop along the word line may be 10V. Conventionally, due to the voltage drop, word line drivers are typically required to support a higher current and/or a total supply voltage is 25 increased.

[0032] The present disclosure describes systems and methods for reading and writing memory cells by reducing the number of activated cells in communication with a selected word line. One method includes segmenting word lines and including multiple word line decoders along the word lines. 30 Another method includes selectively controlling sub-blocks within memory blocks via switches. Using the proposed systems and methods, the voltage drop along a selected word line may be reduced.

[0033] FIG. 3 illustrates one implementation of a memory system 150 including a memory controller 152 in communication with a memory array 200. The memory controller 152 includes a selector module 154 that may control a read/write module 156 based on a memory map 158. The read/write module 156 selects memory cells of the memory array 200 during read and write operations by selectively controlling word lines and bit lines and/or control devices for word lines or bit lines. Control devices for word lines and bit lines may include decoders, global bit lines and/or switch modules.

[0034] Referring now to FIG. 4, a first example of a memory array 200 is shown. The memory array 200 may include blocks 216-1, 216-2, ..., and 216-Q (referred to herein as blocks 216). A block 216 may be further arranged in a predetermined number of sub-blocks 224-1,1, 224-2,1..., and 224-Q,A (referred to herein as sub-blocks 224). The number of sub-blocks 224 may be proportional to the number of blocks 216. In one implementation, instead of writing data only to memory locations along a word line in a single block, data may be written to memory locations – e.g., multiple sub-blocks – of the same block or among different blocks. A sub-block 224 may communicate with a respective word line decoder 206-1,1, 206-1,2, ..., and 206-Q,A (referred to herein as word line decoder 206) and word line drivers 208-1,1, 208-1,2, ..., and 208-Q,A (referred to herein as word line drivers 208) via local word lines 218-1,1, 218-1,2, ..., and 218-Q,V (referred to herein as local word lines 218).

[0035] In one implementation, the read/write module 156 may activate memory cells in a sub-block 224 by controlling a respective word line decoder 206 and word line driver 208. Thus, memory cells may be selectively activated in one or more sub-blocks 224 (of the same block 216 or among different blocks 216), while memory cells may remain deactivated in other sub-blocks 224 (of the same block 216 or among different blocks 216). The read/write module 156 may also control global bit lines 214-1, 214-2, ..., and 214-N (referred to herein as global bit lines 214) that may communicate with multiple sub-blocks 224 within different blocks 216.

[0036] For example, the selector module 154 may control word line decoders 206-Q,1, 206-2,2, and 206-1,A via control inputs 223 to allow

read/write operations to corresponding sub-blocks 224-Q,1, 224-2,2, and 224-1,A. Each sub-block 224 may communicate with a predetermined number of global bit lines 214. For example, when Q=3, so that there are three memory blocks 216 communicating with nine global bit lines 214, each memory block 216 may include three sub-blocks 224 of equal length. Each of the three sub-blocks 224 may communicate with three of the global bit lines 214.

[0037] Using conventional techniques, a word line decoder would have been selected, and a memory block corresponding to the word line decoder would have been written to. In contrast, techniques described in the present disclosure permit the selection of multiple word line decoders/word lines for storing data in multiple sub-blocks 224 (associated with one or more blocks 216), rather than a single memory decoder storing data only in a single block 216.

[0038] In one implementation, a read/write operation to a particular word line is distributed based on word line decoder selection. In one implementation, both data and access to data in cells of a particular word line is distributed among multiple word lines. The memory map 158 may include data relating to word line decoder selection. For example, the read/write module 156 may determine a number of sub-blocks 224 in a block 216. The read/write module 156 may activate a number of word lines in different blocks corresponding to the number of sub-blocks 224 in the block 216. The read/write module 156 may then selectively activate global bit lines 214 and selectively activate sub-blocks 224 along the global bit lines 214.

[0039] The memory array 200 may be further described with reference to an exemplary block 216 as shown in FIGs. 5A-5B. As shown, a sub-block 224 may include local bit lines 225-1,1,1, 225-1,2,1, ..., and 225-W,K,A (referred to herein as local bit lines 225). The local bit lines 225 may be arranged in groups, with each group in communication with a respective multiplexer 222-1,1, 222-K,1, ..., and 222-K,A (referred to herein as multiplexers 222). The multiplexers 222 may select a local bit line 225 from the local bit lines 225 for reading and writing data. Control inputs 227 to the multiplexers 222 may control multiplexer selection of local bit lines 225. The read/write module 156 may provide the control signals to the control inputs 227. The output of the multiplexers 222 may

communicate with global bit lines. The global bit lines may communicate with sub-blocks 224 in each block 216 and with a bit line decoder and/or sense amplifiers. Memory cells 226 may be formed at the intersection of the local word lines 218 and the local bit lines 225. The memory array 200 may reduce the voltage drop along a selected word line 218 by reducing the number of activated memory cells 226 in communication with a selected word line 218.

[0040] For example, as shown in FIG. 5B, local word line 218-1,1 may be active based on control of word line decoder 206-1,1. Multiplexers 222 may select local bit lines 225-W,1,1, 225-W,1,2..., and 225-W,1,K for reading and writing operations. Thus, memory cells 226-1, 226-2, ..., and 226-K may be conducting. Memory cells 226 within other sub-blocks 224 may remain deactivated and thus may not be conducting. The selected word line 218 and bit lines 225 in FIG. 5B are exemplary, and other word lines 218 and bit lines 225 may be selected to activate other memory cells 226. Further, memory cells 226 from one or more sub-blocks 224 may be activated for reading and writing operations.

[0041] According to one implementation of the present disclosure, the number of activated memory cells 226 along the selected word line 218-1,1 may be given by:

$$Y = Z * \left(\frac{L}{A} \right),$$

where L is the number of multiplexers 222 in a block 216, A is the number of sub-blocks 224 per block 216, and Z is the number of sub-blocks 224 with activated memory cells 226. In a conventional memory array, there may have been L activated memory cells 226 along the selected word line 218-1,1. The voltage drop along the selected word line 218-1,1 may be directly proportional to the number of activated memory cells 226 in communication with the selected word line 218-1,1. Therefore, the voltage drop along the selected word line 218-1,1 may be reduced by a factor of Z/A. For example, if Z is equal to one, as in FIG. 5B, the voltage drop along the activated word line 218-1,1 is reduced by a factor of 1/A.

[0042] Referring now to FIGs. 6A-6C, a second example of a memory array 300 is shown. The memory array 300 may include blocks 316-1, 316-2,

..., and 316-Q (referred to herein as blocks 316). A block 316 may communicate with a respective word line decoder 306-1, 306-2, ..., and 306-Q (referred to herein as word line decoder 306) and word line drivers 308-1, 308-2, ..., and 308-Q (referred to herein as word line drivers 308) via local word lines 318-1,1, 318-2,1, ..., and 318 Q,V (referred to herein as local word lines 318). Each block may include a plurality of sub-blocks 317-1,1, 317-2,1, ..., and 317A,Q (referred to herein as sub-blocks 317).

[0043] A block 316 may also communicate with switch modules 319-1,1, 319-2,1..., and 319-A,Q (referred to herein as switch modules 319) via global bit lines 314-1, 314-2, ..., and 314-N (referred to herein as global bit lines 314) and local bit lines 320-1,1, 320-2,1, ..., and 320-W,K (referred to herein as local bit lines 320). Each switch module 319 may communicate with a respective sub-block 317. A bit line decoder 309 may select memory cells 321 for reading and/or writing operations via the global bit lines 314. Sense amplifiers 310 may detect the presence or absence of data in the memory cells 321.

[0044] Referring now to FIG. 6B, the switch modules 319 may include multiplexers 322-1, 322-2, ..., and 322-K (referred to herein as multiplexers 322). The read/write control module 156 may provide control signals to control inputs 327 of the multiplexers 322 to control local word line selection. The switch modules 319 may also include switches 326-1, 326-2, ..., and 326-K (referred to herein as switches 326) that may be controlled by select signals from the selector module 154. The switches 326 within a switch module 319 may be controlled by the same select signal.

For example, each switch 326 in a first switch module 319 may be controlled by a first select signal (s_0), each switch 326 in a second switch module 319 may be controlled by a second select signal (s_1), etc. Thus, each switch 326 within a switch module 319 may be on or off at the same time. Additionally, multiple switch modules 319 may be controlled by the same select signal. For example, a wordline in each K out of Q blocks 316 may be used to turn on K groups of sub-blocks 317 based on control of K x M of the Q x M switches 326 by a corresponding select signal. K may be less than or equal to Q. In one embodiment, the sub-blocks 317 may be grouped into groups of O elements,

where $O=M/K$. The groups may each be controlled by one or more select signals that control, for example, the $K \times M$ of the $Q \times M$ switches 326. One or more of M/K memory sub-blocks 317 in each of the K out of Q blocks 316 may thus be accessed during a read or write operation.

5 **[0045]** A block 316 may have Q switch modules 319, with each switch module 319 having L/Q switches, where L is the number of multiplexers 322 per block 316. The memory array 300 may reduce the voltage drop along a selected word line 318 by reducing the number of activated memory cells in communication with the selected word line 318.

10 **[0046]** In one implementation, within a block 316, each switch module 319 may be controlled by a different select signal (s_0 - s_A), as shown in FIG. 6C. Thus, switches 326 within a switch module 319 may be controlled by the same select signal. The select signals may be arranged so that two or more switch modules 319 in communication with a global bit line 314 may not be selected at
15 the same time. The selector module 154 may provide the select signals based on a memory map 158.

[0047] For example, the select signals may be cascaded within the memory array 300 based on the memory map 158. In block 316- Q , switch module 319-1, Q may have a first select signal (s_0), switch module 319-2, Q may
20 have a second select signal (s_1), ..., and switch module 319- A , Q may have an A th select signal (s_A). In block 316-3, switch module 316-1,3 may have the A th select signal (s_A), switch module 319-2,3 may have the first select signal (s_0), ..., and switch module 319- A ,3 may have an A th-1 select signal (s_{A-1}). The select signals may be similarly distributed throughout the memory array 300. Thus, by
25 activating the first select signal and activating a word line 318 within each block 316, memory cell activation may be distributed among the blocks 316.

[0048] As shown in FIG. 6C, each block 316 may have one activated word line 318. Further, each block 316 may have one activated switch module 319. Thus, there may be K activated memory cells 321 in communication with
30 the activated word line 318 and the activated switch module 319. The memory cells 321 are included to graphically represent memory cells that correspond to local bit lines 320 that are controlled based on global bit lines 314 and are not

intended to show memory cells at intersections of global bit lines 314 and word lines 218. Where there are K activated memory cells 321 per activated switch module 319 and A activated switch modules 319, there may be $K \cdot A = L$ activated memory cells 321 per memory array 300. Thus, a total of L memory cells 321 may be read in a read cycle. In a conventional memory array, L memory cells 321 are typically read from a single block 316. In the memory array 300 according to one implementation of the present disclosure, the L memory cells 321 may be read from multiple different blocks 316.

[0049] Using the memory array 300 according to the present disclosure, the number of activated memory cells 321 along the selected word line 318 may be given by:

$$Y = \left(\frac{L}{Q} \right),$$

where L is the number of multiplexers 322 in a block 316 and Q is the number of blocks 316. Previously, there may have been L activated memory cells 321 along the selected word line 318. Since the voltage drop along the selected word line 318 is directly proportional to the number of activated memory cells 321 in communication with the selected word line 318, the voltage drop along the selected word line 318 is reduced by a factor of $1/Q$.

[0050] Referring now to FIG. 7 the memory array 300 may be further described. FIG. 7 illustrates an exemplary memory array 300 where $Q = 4$ and $L = 4$. In other words, there are four blocks 316 and four multiplexers 322 per block 316. Where there are four blocks 316, there may be four switch modules 319 per block 316. Each switch module 319 may have L/Q switches 326. In the case shown in FIG. 7, where $Q = 4$ and $L = 4$, there is one switch 326 per switch module 319.

[0051] During a read and/or write cycle, one local word line 318 may be activated per block 316. For example, the word line drivers 308 may apply a voltage to local word line 318-1,1, 318-1,2, 318-1,3, and 318-1,4 in each block 316. One select signal may be activated to turn on a set of switches 326. For example, select signal s_0 may be activated, thus turning on switches 326-1,4, 326-2,3, 326-3,2, and 326-4,1. As shown in FIG. 7, there may be four activated

memory cells 321-1,4, 321-2,3, 321-3,2, and 321-4,1. The remaining select signals (s_1 - s_3) may remain deactivated. Thus there may not be capacitive and/or leakage current flowing through unselected memory cells 329 controlled by select signals s_1 - s_3 and multiplexors because the closed switches 326 prevent
5 current flow.

[0052] Thus, the number of activated memory cells 321 along the selected word line 318-1,1 may be given by:

$$Y = \left(\frac{L}{Q} \right) = \left(\frac{4}{4} \right) = 1.$$

In a conventional memory array, there may have been four activated memory
10 cells 321 along the selected word line. Since the voltage drop along the selected word lines 318 is directly proportional to the number of activated memory cells 321 in communication with the selected word lines 318, the voltage drop along the selected word lines 318 is reduced by a factor of 1/4.

[0053] The broad teachings of this disclosure can be implemented in a
15 variety of forms. Therefore, while this disclosure includes particular examples, the true scope of the disclosure should not be so limited since other modifications will become apparent upon a study of the drawings, the specification, and the following claims.

CLAIMS

What is claimed is:

1. A memory system comprising:
5 Q memory blocks, each of the Q memory blocks including M memory sub-blocks;
Q word line decoders, each of the Q word line decoders being associated with a different one of the Q memory blocks;
a bit line decoder; and
10 Q x M switch modules, each Q x M switch module selectively controlling access to one of the M memory sub-blocks of the Q memory blocks, wherein the Q word line decoders and the bit line decoder access less than M memory sub-blocks in at least two of the Q memory blocks during one of a read and write operation,
15 wherein M and Q are integers greater than 1.
2. The memory system of claim 1, further comprising a memory control module that selectively controls the Q x M switch modules based on a memory map.
20
3. The memory system of claim 1, further comprising M global bit lines, wherein each of the M global bit lines corresponds to a respective one of the M memory sub-blocks.
- 25 4. The memory system of claim 3, wherein:
each of the M memory sub-blocks of the Q memory blocks includes one or more local bit lines;
each of the Q x M switch modules includes a switching device that selectively connects one of the M global bit lines to one or more of the local bit
30 lines of the M memory sub-blocks of the Q memory blocks.

5. The memory system of claim 4, wherein the $Q \times M$ switch modules further include one of a multiplexer and a demultiplexer that also selectively connect the one of the M global bit lines to the one or more local bit lines of the M memory sub-blocks of the Q memory blocks.

5

6. The memory system of claim 5, wherein the switching device includes:

one of a diode and a transistor having a control terminal that receives a switch control signal;

10 a first terminal that communicates with the one of the M global bit lines; and

a second terminal that communicates with one of the multiplexer and the demultiplexer.

15 7. The memory system of claim 1, further comprising memory cells that correspond to intersections of word lines and bit lines that traverse the Q memory blocks.

20 8. The memory system of claim 7, wherein K of the Q word line decoders activate a plurality of the word lines during the one of the read and write operation, wherein each of the plurality of the word lines traverses a different one of the K of the Q memory blocks, wherein K is less than Q .

25 9. The memory system of claim 8, wherein one or more of M/K of the M memory sub-blocks in each of the K of the Q memory blocks is accessed during the one of the read and write operation based on control of $K \times M$ of the $Q \times M$ switch modules.

30 10. The memory system of claim 9, wherein one group of the $Q \times M$ switch modules allows access to one group of the M memory sub-blocks for each one of the K of the Q memory blocks during the one of the read and write operation.

11. A memory system comprising:
a memory array, the memory array including,
a plurality of bit lines;
a plurality of word lines; and
5 a plurality of memory cells, each memory cell being formed
at a corresponding intersection of a bit line and a word line in the memory
array; and

a read/write module to control activation of at least two memory
cells in the memory array during a read operation or a write operation,

10 wherein the at least two memory cells activated by the read/write
control module are located on a different word line and a different bit line in the
memory array.

12. A method for accessing memory comprising:

15 selectively controlling access to one of M memory sub-blocks of Q
memory blocks by selectively controlling each of Q x M switch modules; and

accessing less than M memory sub-blocks in at least two of the Q
memory blocks by activating a bit line and word lines associated with the at least
two of the Q memory blocks during one of a read and write operation,

20 wherein M and Q are integers greater than 1.

13. The method of claim 12, further comprising selectively controlling
the Q x M switch modules based on a memory map.

25 14. The method of claim 12, further comprising selectively connecting
one of M global bit lines to one or more of local bit lines of the M memory sub-
blocks of the Q memory blocks by controlling a switching device in each of the Q
x M switch modules.

30 15. The method of claim 14, further comprising selectively connecting
the one of the M global bit lines to the one or more local bit lines of the M

memory sub-blocks of the Q memory blocks via one of a multiplexer and a demultiplexer.

16. The method of claim 15, further comprising receiving a switch
5 control signal;

communicating through a switching device with the one of the M
global bit lines; and

communicating through the switching device with one of the
multiplexer and the demultiplexer.

10

17. The method of claim 12, further comprising storing data in memory
cells that correspond to intersections of word lines and bit lines that traverse the
Q memory blocks.

18. The method of claim 17, further comprising activating a plurality of
15 the word lines during the one of the read and write operation, wherein each of
the plurality of the word lines traverses a different one of K of the Q memory
blocks, wherein K is less than Q.

19. The method of claim 18, further comprising accessing one or more
20 of M/K of the M memory sub-blocks in each of the K of the Q memory blocks
during the one of the read and write operation based on control of K x M of the Q
x M switch modules.

20. A method comprising:
25 forming a plurality of memory cells at a corresponding intersection
of a bit line and a word line in a memory array; and

controlling activation of at least two memory cells in the memory
array during a read operation or a write operation,

30 wherein the at least two memory cells are located on a different
word line and a different bit line in the memory array.

AMENDED CLAIMS

received by the International Bureau on 15 July 2009 (15.07.2009)

What is claimed is:

1. A memory system comprising:
 - 5 Q memory blocks, each of the Q memory blocks including M memory sub-blocks;
 - Q word line decoders, each of the Q word line decoders being associated with a different one of the Q memory blocks;
 - a bit line decoder; and
 - 10 Q x M switch modules, each Q x M switch module selectively controlling access to one of the M memory sub-blocks of the Q memory blocks, wherein the Q word line decoders and the bit line decoder access less than M memory sub-blocks in at least two of the Q memory blocks during one of a read and write operation,
 - 15 wherein M and Q are integers greater than 1.
2. The memory system of claim 1, further comprising a memory control module that selectively controls the Q x M switch modules based on a memory map.
- 20 3. The memory system of claim 1, further comprising M global bit lines, wherein each of the M global bit lines corresponds to a respective one of the M memory sub-blocks.
- 25 4. The memory system of claim 3, wherein:
 - each of the M memory sub-blocks of the Q memory blocks includes one or more local bit lines;
 - each of the Q x M switch modules includes a switching device that selectively connects one of the M global bit lines to one or more of the local bit
 - 30 lines of the M memory sub-blocks of the Q memory blocks.

5. The memory system of claim 4, wherein the $Q \times M$ switch modules further include one of a multiplexer and a demultiplexer that also selectively connect the one of the M global bit lines to the one or more local bit lines of the M memory sub-blocks of the Q memory blocks.

5

6. The memory system of claim 5, wherein the switching device includes:

one of a diode and a transistor having a control terminal that receives a switch control signal;

10 a first terminal that communicates with the one of the M global bit lines; and

a second terminal that communicates with one of the multiplexer and the demultiplexer.

15 7. The memory system of claim 1, further comprising memory cells that correspond to intersections of word lines and bit lines that traverse the Q memory blocks.

20 8. The memory system of claim 7, wherein K of the Q word line decoders activate a plurality of the word lines during the one of the read and write operation, wherein each of the plurality of the word lines traverses a different one of the K of the Q memory blocks, wherein K is less than Q .

25 9. The memory system of claim 8, wherein one or more of M/K of the M memory sub-blocks in each of the K of the Q memory blocks is accessed during the one of the read and write operation based on control of $K \times M$ of the $Q \times M$ switch modules.

30 10. The memory system of claim 9, wherein one group of the $Q \times M$ switch modules allows access to one group of the M memory sub-blocks for each one of the K of the Q memory blocks during the one of the read and write operation.

11. A memory system comprising:
a memory array, the memory array including,
a plurality of bit lines;
a plurality of word lines; and
5 a plurality of memory cells, each memory cell being formed at
a corresponding intersection of a bit line and a word line in the memory array; and
a read/write module to control activation of at least two memory cells
in the memory array during a read operation or a write operation,
wherein the at least two memory cells activated by the read/write
10 control module are located on different word lines and different bit lines in the
memory array, wherein memory cells other than the at least two memory cells are
not activated along the different word lines and the different bit lines during the read
operation or the write operation.
12. A method for accessing memory comprising:
selectively controlling access to one of M memory sub-blocks of Q
memory blocks by selectively controlling each of Q x M switch modules; and
accessing less than M memory sub-blocks in at least two of the Q
memory blocks by activating a bit line and word lines associated with the at least
20 two of the Q memory blocks during one of a read and write operation,
wherein M and Q are integers greater than 1.
13. The method of claim 12, further comprising selectively controlling the
Q x M switch modules based on a memory map.
14. The method of claim 12, further comprising selectively connecting one
of M global bit lines to one or more of local bit lines of the M memory sub-blocks of
the Q memory blocks by controlling a switching device in each of the Q x M switch
modules.
15. The method of claim 14, further comprising selectively connecting the
one of the M global bit lines to the one or more local bit lines of the M memory sub-
blocks of the Q memory blocks via one of a multiplexer and a demultiplexer.

16. The method of claim 15, further comprising receiving a switch control signal;

communicating through a switching device with the one of the M global bit lines; and

5 communicating through the switching device with one of the multiplexer and the demultiplexer.

17. The method of claim 12, further comprising storing data in memory cells that correspond to intersections of word lines and bit lines that traverse the Q
10 memory blocks.

18. The method of claim 17, further comprising activating a plurality of the word lines during the one of the read and write operation, wherein each of the plurality of the word lines traverses a different one of K of the Q memory blocks,
15 wherein K is less than Q.

19. The method of claim 18, further comprising accessing one or more of M/K of the M memory sub-blocks in each of the K of the Q memory blocks during the one of the read and write operation based on control of K x M of the Q x M
20 switch modules.

20. A method comprising:
forming a plurality of memory cells at a corresponding intersection of a bit line and a word line in a memory array; and
25 controlling activation of at least two memory cells in the memory array during a read operation or a write operation,
wherein the at least two memory cells are located on a different word line and a different bit line in the memory array.

30 14598853

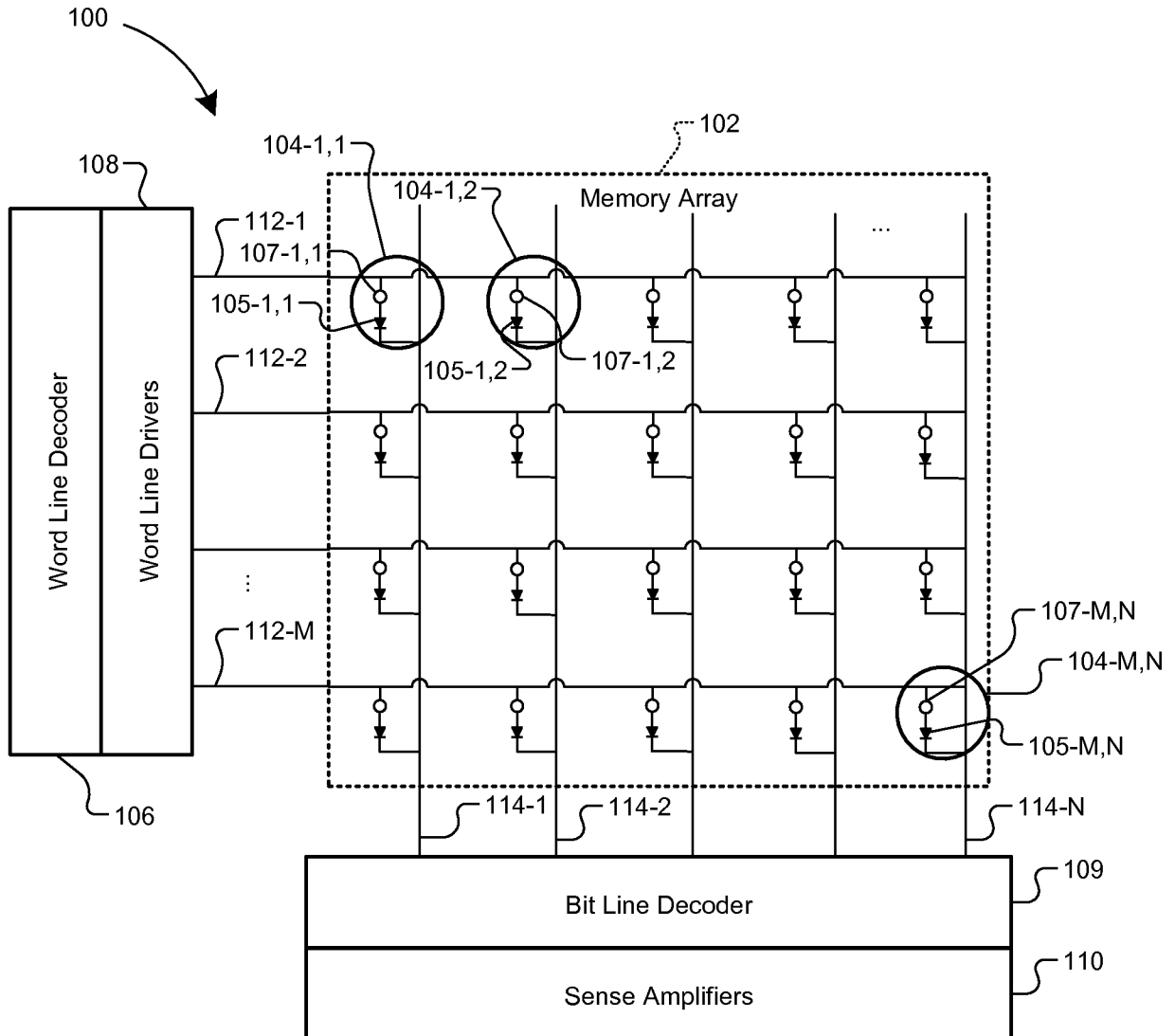

FIG. 1
Prior Art

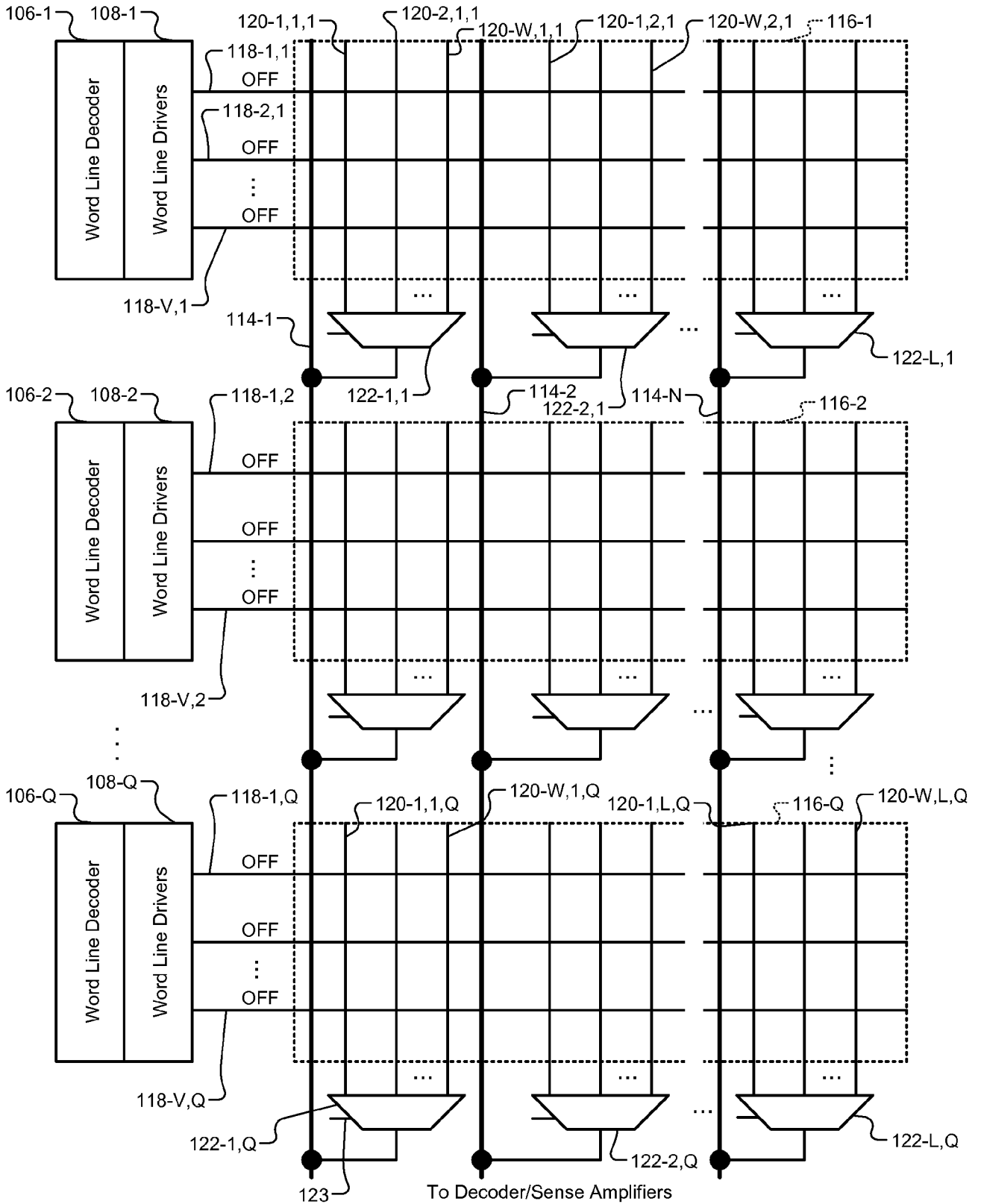

FIG. 2A
Prior Art

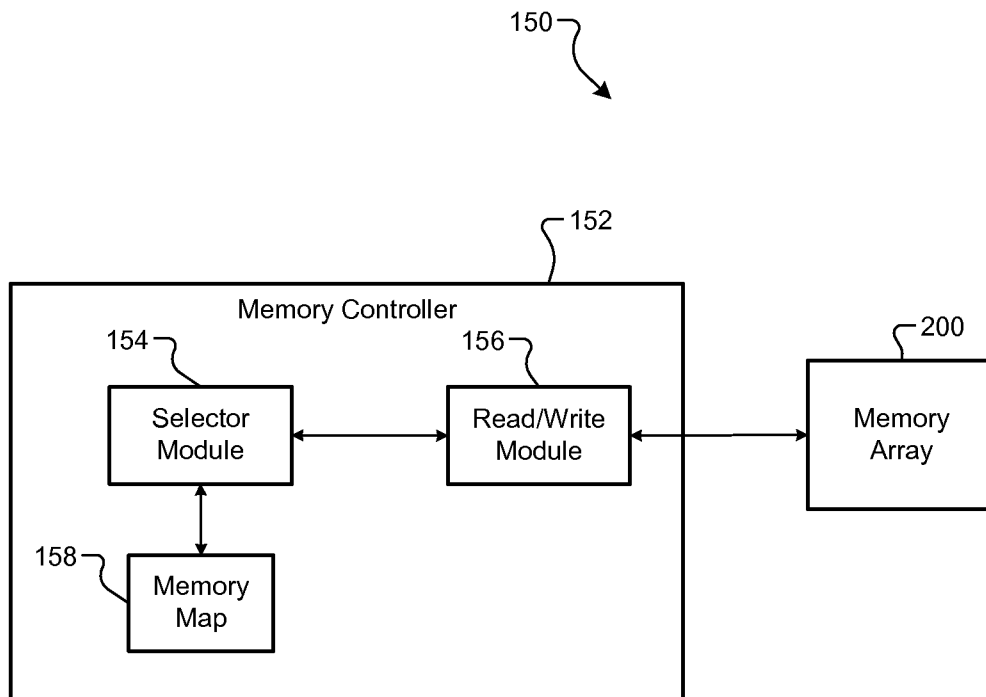

FIG. 3

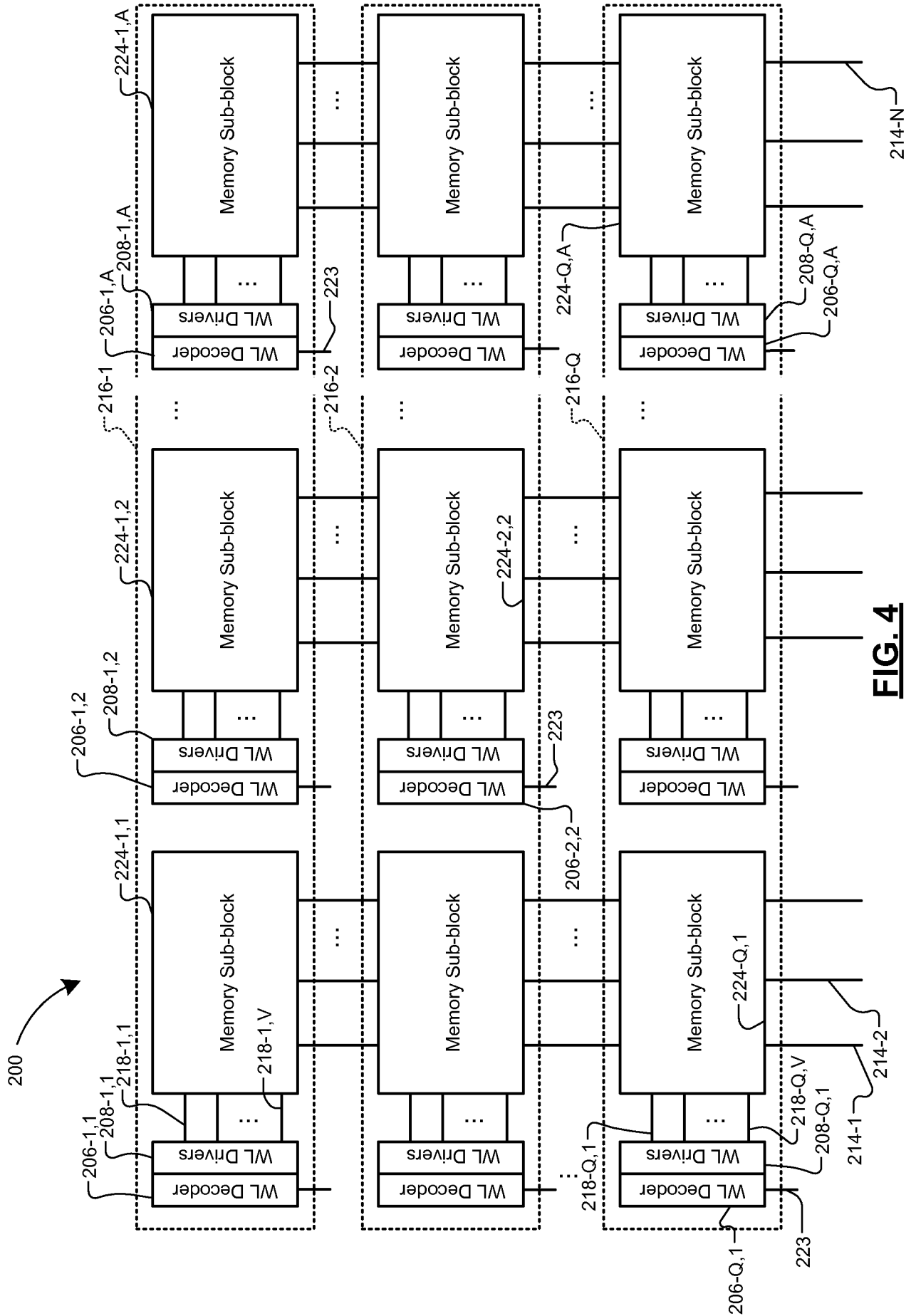

FIG. 4

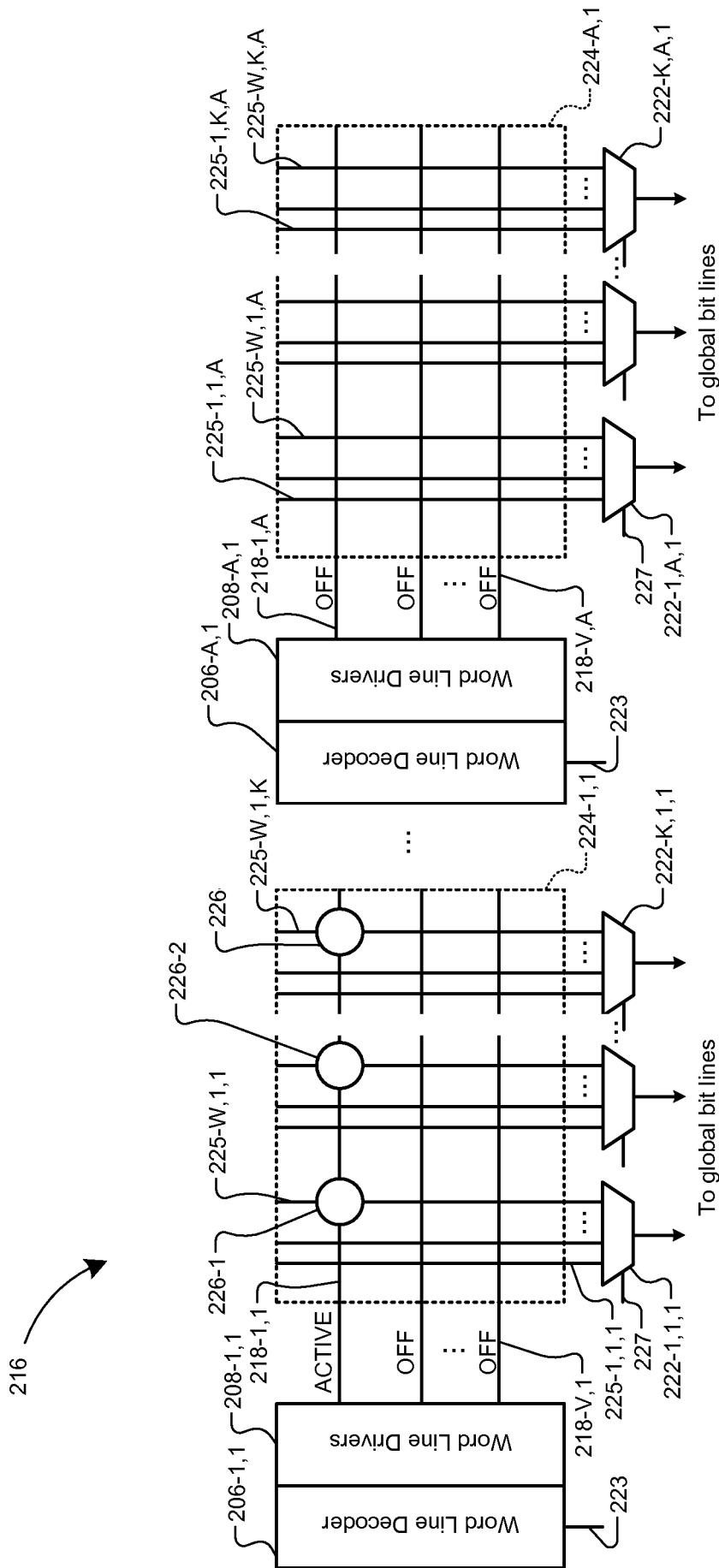

FIG. 5B

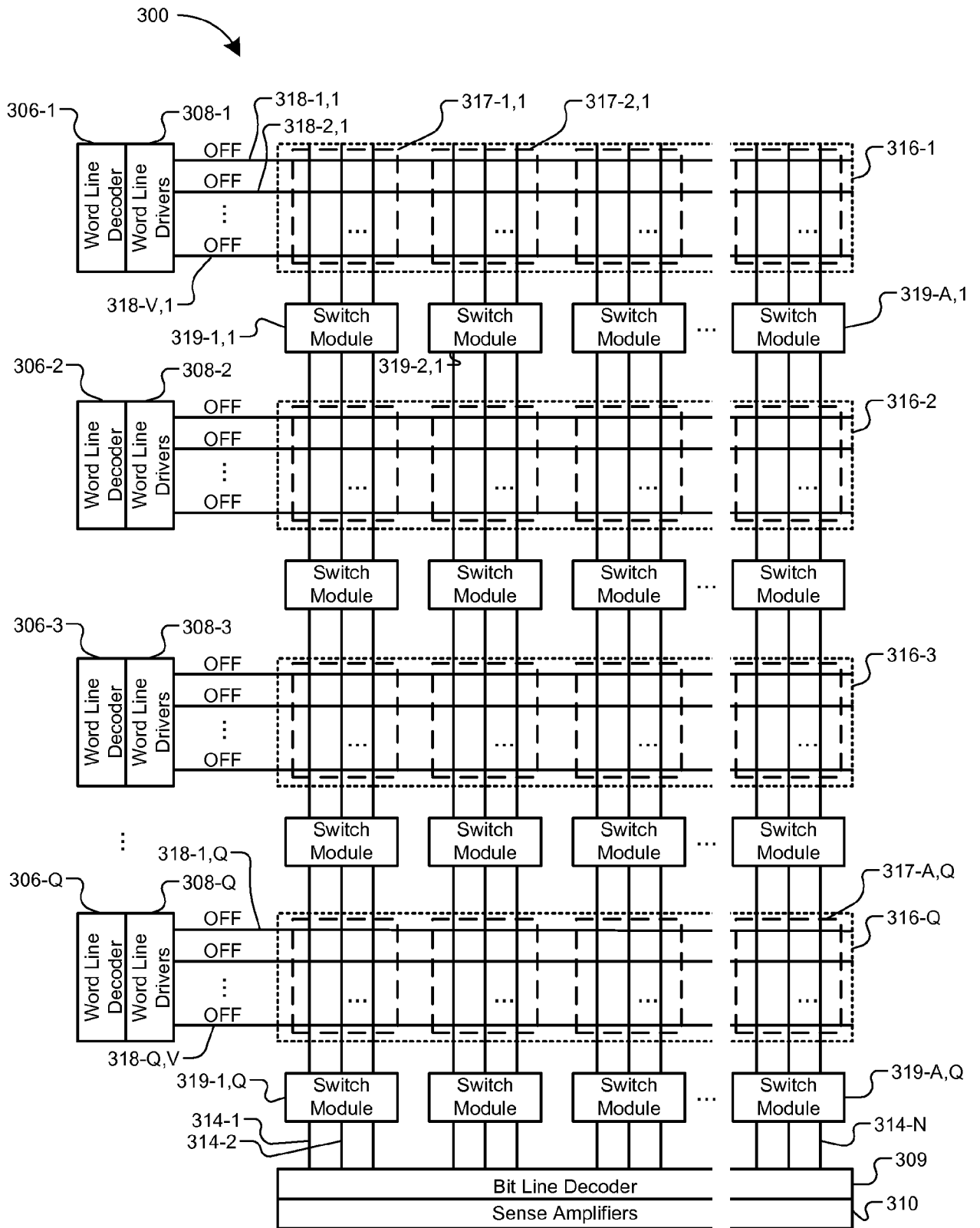

FIG. 6A

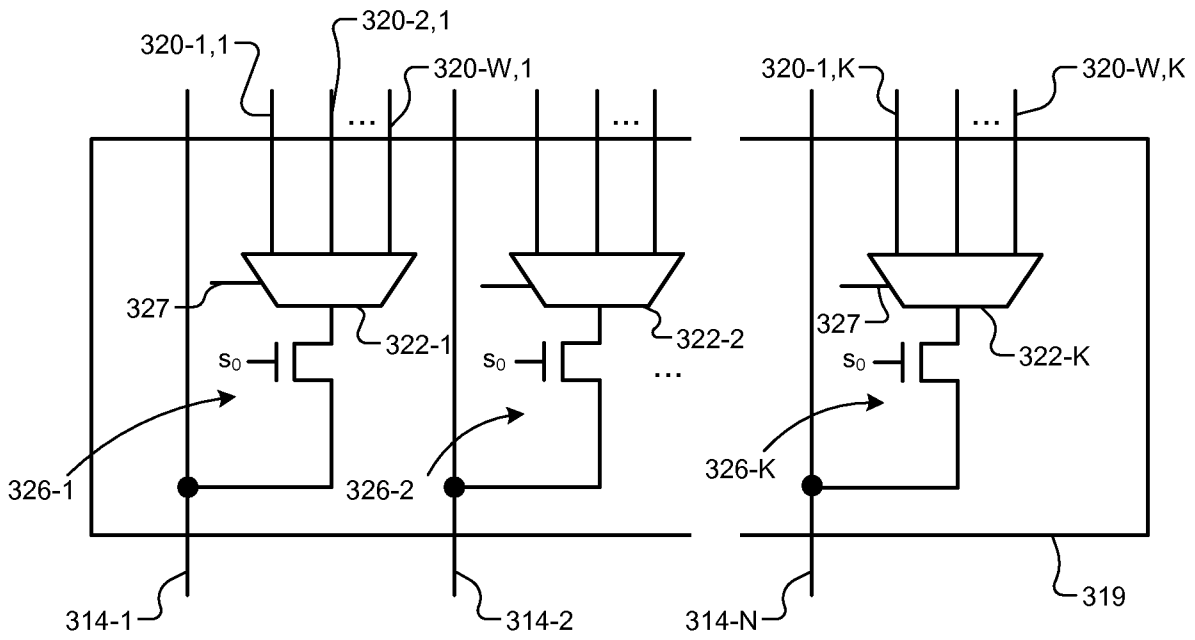

FIG. 6B

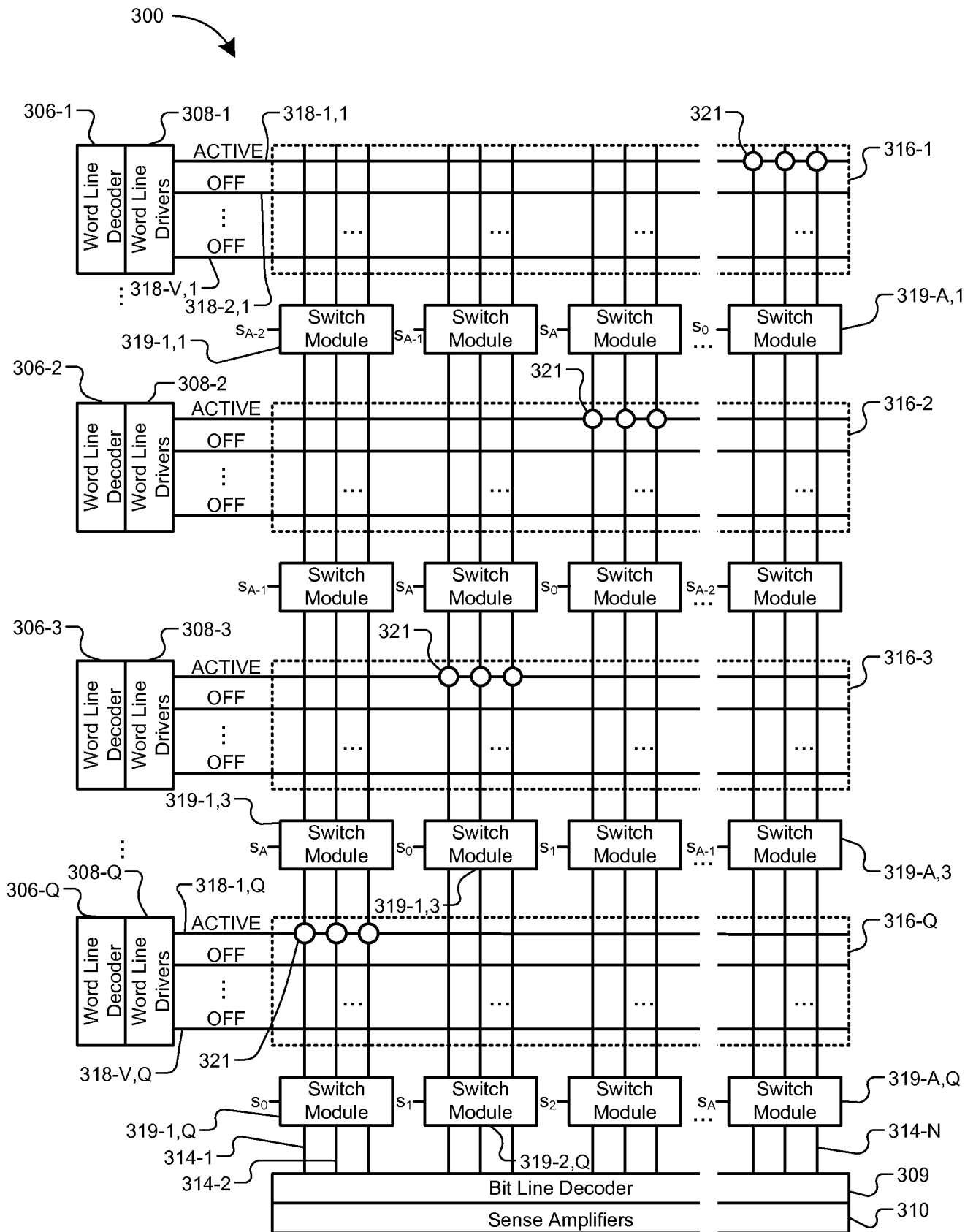

FIG. 6C

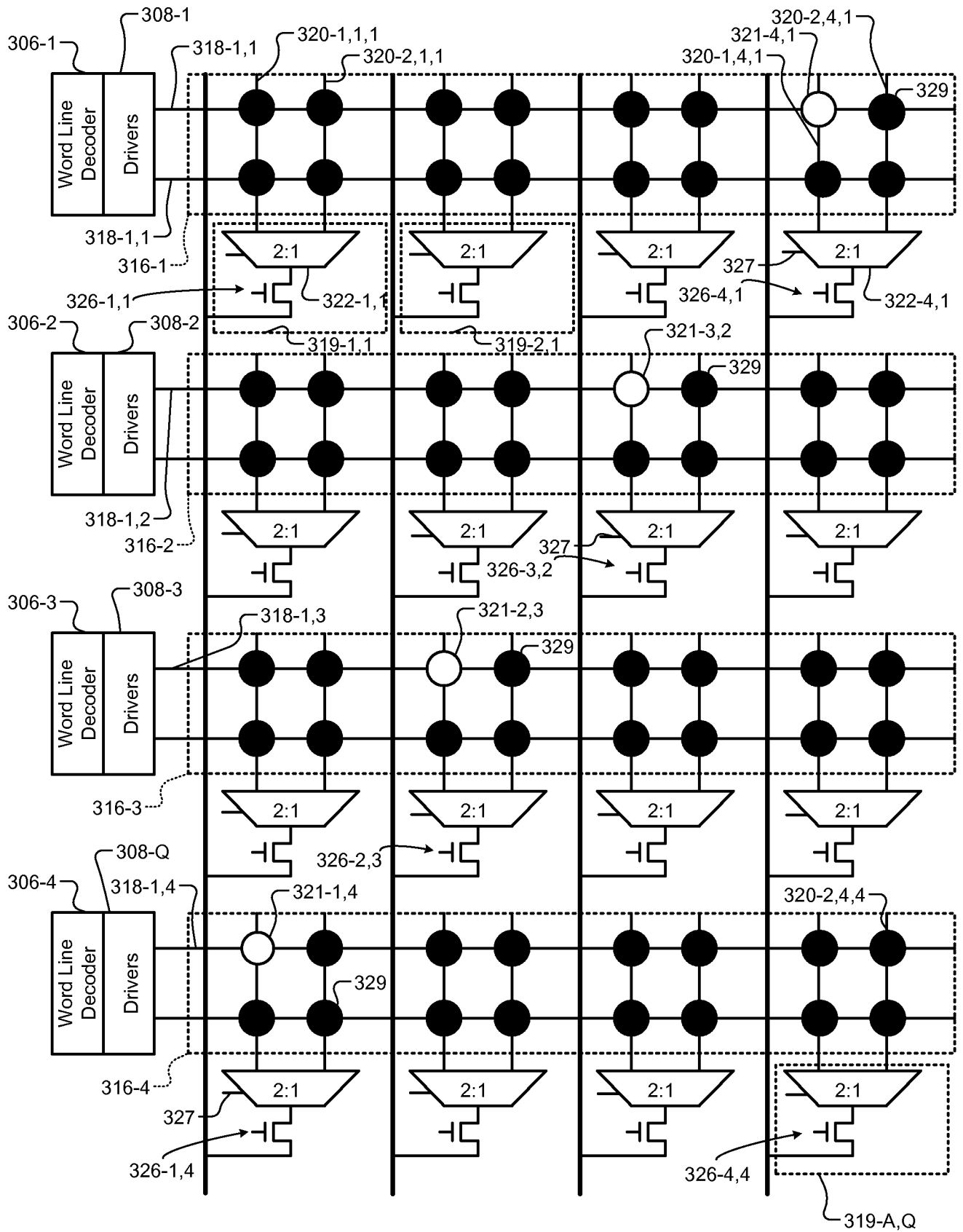

FIG. 7

INTERNATIONAL SEARCH REPORT

International application No
PCT/US2009/033040

A. CLASSIFICATION OF SUBJECT MATTER

INV. G11C8/14 G11C7/18 G11C7/10

According to International Patent Classification (IPC) or to both national classification and IPC.

B. FIELDS SEARCHED

Minimum documentation searched (classification system followed by classification symbols)

G11C

Documentation searched other than minimum documentation to the extent that such documents are included in the fields searched

Electronic data base consulted during the international search (name of data base and, where practical, search terms used)

EPO-Internal

C. DOCUMENTS CONSIDERED TO BE RELEVANT

Category*	Citation of document, with indication, where appropriate, of the relevant passages	Relevant to claim No.
X	EP 1 708 202 A (SAMSUNG ELECTRONICS CO LTD [KR]) 4 October 2006 (2006-10-04) paragraphs [0008] - [0011] paragraphs [0014] - [0022]; figures 3-6	1, 3-7, 12, 14-17
X	US 6 198 667 B1 (JOO YANG-SUNG [KR]) 6 March 2001 (2001-03-06) column 1, line 6 - line 15 column 3, line 38 - column 4, line 5 column 4, line 46 - column 6, line 14; figure 5	11, 20
A	US 6 104 663 A (KABLANIAN ADAM [US]) 15 August 2000 (2000-08-15) abstract; figures 2a, 5	11, 20
	-/--	

Further documents are listed in the continuation of Box C.

See patent family annex.

* Special categories of cited documents :

A document defining the general state of the art which is not considered to be of particular relevance

E earlier document but published on or after the international filing date

L document which may throw doubts on priority claim(s) or which is cited to establish the publication date of another citation or other special reason (as specified)

O document referring to an oral disclosure, use, exhibition or other means

P document published prior to the international filing date but later than the priority date claimed

T later document published after the international filing date or priority date and not in conflict with the application but cited to understand the principle or theory underlying the invention

X document of particular relevance; the claimed invention cannot be considered novel or cannot be considered to involve an inventive step when the document is taken alone

Y document of particular relevance; the claimed invention cannot be considered to involve an inventive step when the document is combined with one or more other such documents, such combination being obvious to a person skilled in the art.

& document member of the same patent family

Date of the actual completion of the international search

12 May 2009

Date of mailing of the international search report

19/05/2009

Name and mailing address of the ISA/

European Patent Office, P.B. 5818 Patentlaan 2
NL - 2280 HV Rijswijk
Tel. (+31-70) 340-2040,
Fax: (+31-70) 340-3016

Authorized officer

Wolff, Norbert

INTERNATIONAL SEARCH REPORT

International application No
PCT/US2009/033040

C(Continuation). DOCUMENTS CONSIDERED TO BE RELEVANT		
Category*	Citation of document, with indication, where appropriate, of the relevant passages	Relevant to claim No.
A	EP 0 834 881 A (SGS THOMSON MICROELECTRONICS [IT]) 8 April 1998 (1998-04-08) abstract; figures 3,4 -----	1-10, 12-19
A	EP 1 376 597 A (BROADCOM CORP [US]) 2 January 2004 (2004-01-02) abstract; figure 3B -----	1-10, 12-19