

H. F. AMBOS.  
STEAM ENGINE.

No. 109,167.

Patented Nov. 15, 1870.

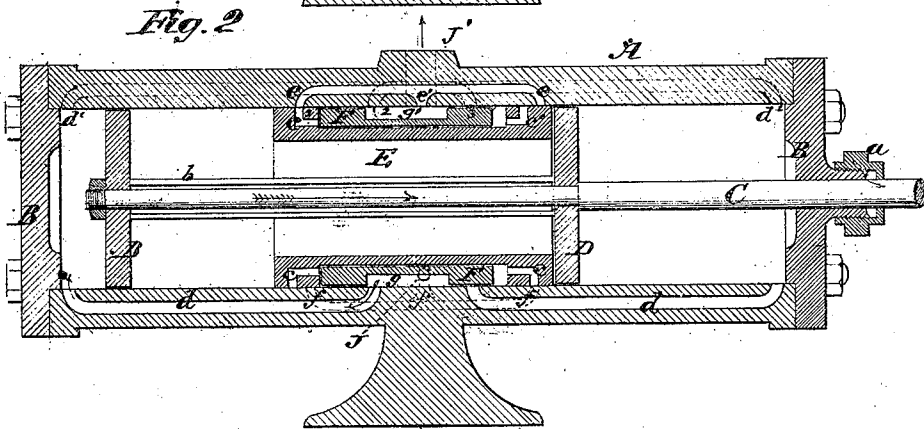
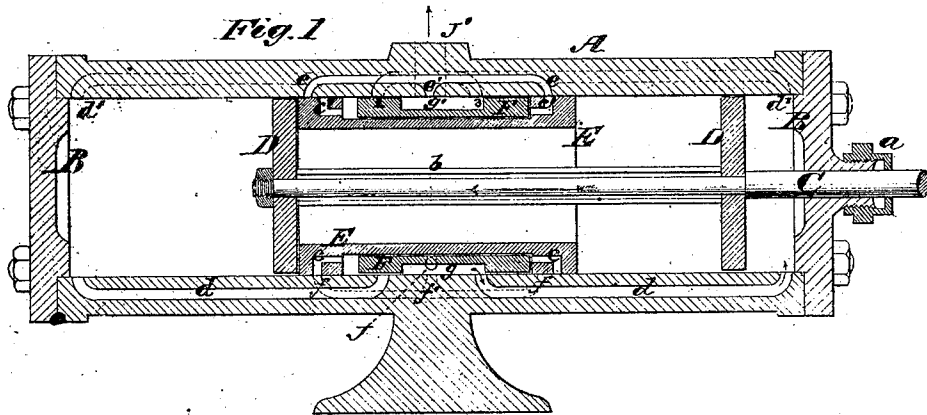
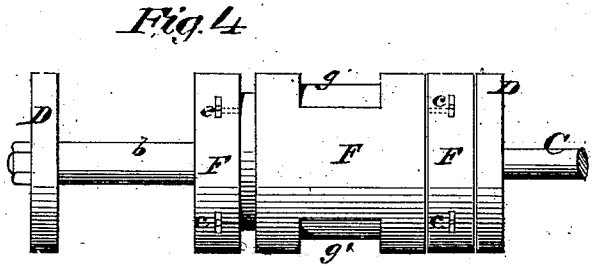
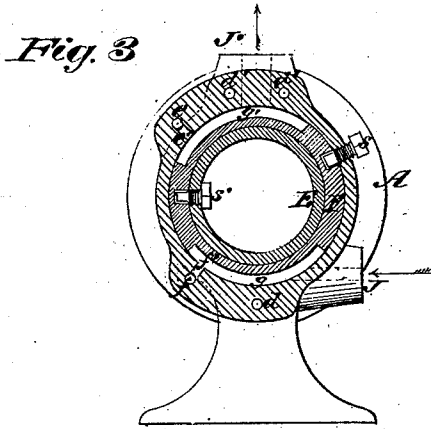

*Witnesses*  
*R. Campbell.*  
*J. S. Campbell.*

*Inventor*  
*Herman H. Ambos*  
*by his atty*  
*Masw. Fenwick Lawrence*

# UNITED STATES PATENT OFFICE.

HERMAN F. AMBOS, OF COLUMBUS, OHIO.

## IMPROVEMENT IN STEAM-ENGINES.

Specification forming part of Letters Patent No. 109,167, dated November 15, 1870.

*To all whom it may concern:*

Be it known that I, HERMAN F. AMBOS, of Columbus, in the county of Franklin and State of Ohio, have invented an Improved Steam-Engine for Working Pumps; and I do hereby declare that the following is a full, clear, and exact description thereof, reference being had to the accompanying drawing, making part of this specification, in which—

Figure 1 is a diametrical section through the engine, indicating the interior parts at the commencement of the left-hand stroke. The steamways in this figure are all shown by the aid of dotted and full lines in the same plane to simplify the description of them. Fig. 2 is a similar view of the same parts, indicating the piston and its ported cylinder and valve-box at the commencement of the right-hand stroke. Fig. 3 is a cross-section through the cylinder, taken on one side of the middle of its length, showing the steamways in their proper places. Fig. 4 is an exterior view of the piston-heads, their rod, the ported cylinder and the valve-box.

Similar letters of reference indicate corresponding parts in the several figures.

This invention relates to an improved steam-engine which is especially adapted for operating pumping-engines.

The invention consists in a novel arrangement of a valve-box and ported cylinder within the main cylinder and between two piston-heads, and also in a novel arrangement of steamways in the main cylinder-shell, whereby a regular reciprocating motion is imparted to the piston-rod, and may be thence transmitted to a pump or other thing to be driven.

It will be hereinafter shown that all the mechanism for alternately cutting off steam from opposite ends of the main cylinder is contained within the shell of this cylinder, and between the two piston-heads, and that this cutting off and letting on of steam at proper times is effected by the direct action of the piston-heads upon a ported endwise-moving box or slide-valve.

To enable others skilled in the art to understand my invention, I will explain its construction and operation.

In the accompanying drawing, A represents a steam-cylinder, which is cast with a number

of inlet and exhaust passages or ports, hereinafter explained, and provided with heads B B, through one of which and a stuffing-box, *a*, the piston-rod C passes. This cylinder A is smoothly bored out, and has fitted within it two piston-heads, D D, which are secured on the rod C at the proper distance apart, regulated by the length of the cylinder A.

In the shell of the cylinder A steamways are formed, as indicated in the drawing.

There are two steamways, *d d*, for the entrance of steam at opposite ends of the cylinder A. From the outlet *J'* there are two steamways, *d' d'*, which cross each other at the middle of the length of the cylinder, as indicated by dotted lines, Figs. 1 and 2, for the escape of exhaust-steam from opposite ends of the cylinder A to the outlet *J'*; and there are also two steamways, *e f*, the offices of which will be hereinafter explained.

Between the two piston-heads D D is a ported cylinder, E, which is bored through and fitted to work endwise and steam-tight in the cylinder A. This cylinder E is turned so as to form an annular recess into its periphery, which recess leaves annular shoulders at its ends, as shown in Figs. 1, 2, and 4. Ports of right-angular form are made into the cylinder E, leading from the peripheries of the shoulders above mentioned into the annular recess which is between these shoulders. The two ports *c c* are at certain times caused to register alternately with the extremities of the steamway *f*, and the two ports *e' e'* are at certain times caused to register alternately with the extremities of the steamway *e*. Between the annular shoulders of cylinder E, and fitted snugly but loosely around this cylinder, is a cylindrical endwise-movable valve, F, having two chambers, *g g'*, formed into its periphery. This valve F is shorter than the length of space between the shoulders of cylinder E, to allow of the said endwise movement; and the ends of this valve are smoothly dressed, so that when it is in contact with either one of the said shoulders it will tightly close the angular ports *e e'* therein. The circumference of valve F works steam-tight in contact with the inner surface of the cylinder A. The ported cylinder and its valve are arranged at the middle of the length of the main

cylinder A, and are moved by the direct action of the piston-heads D when the latter are near the termination of their strokes.

Fig. 1 shows the position of the cylinder E and valve F relatively to the steamways at the commencement of the left-hand stroke of the pistons. Steam enters through inlet J, and passes through the right-hand steamway, *d*, into cylinder A, thus forcing the pistons D toward the left hand. While this is taking place the exhaust-steam will escape from the opposite end of the cylinder A, through the left-hand steamway, *d'*, into valve-recess *g'*, and out through pipe J'. At the same time the left-hand port, *e*, will be in communication with valve-recess *g*, and the right-hand port, *e'*, will be in communication with valve-recess *g'*, as shown in Fig 1. When the pistons have nearly completed their left-hand stroke, the right-hand piston will move the cylinder E until the right-hand port, *e*, registers with the steamway *f*, and the left-hand port registers with the steam-exhaust way *f'*. Steam will then move valve F to the position shown in Fig. 2, and thus open the steamway *d* on the left of the cylinder, and at the same time open the exhaust-way *d'* on the right of the cylinder, which will cause the pistons to make a return stroke.

Thus it will be seen that the ported cylinder E is operated alternately by the pistons, to allow steam to act upon the slide-valve F, which latter alternately opens and shuts the steam inlet and outlet ways or ports. The first

movement which takes place is that of the pistons; the second, that of the ported cylinder; third, that of the valve, which latter reverses the direction of the steam-currents, and thus changes the direction of movement of the pistons.

In the cross-section, Fig. 3, I have shown the steamways in the proper relation to each other and to the valve-recesses; but, as previously stated, I have indicated all the steamways in the same plane in Figs. 1 and 2 merely to facilitate the description. In Fig. 3 I have also shown two screws, S S', which prevent the valves and their ported cylinder from turning about their axis, but allow them to receive free endwise movement.

Having described my invention, what I claim as new, and desire to secure by Letters Patent, is—

1. The cylindrical valve F, recessed and applied to the shouldered and ported cylinder E, said valve and cylinder being arranged between piston-heads D D, and within a cylinder which has steamways arranged substantially as described.

2. The exhaust-ways *d' d'*, crossed as described, in combination with the valve F, ported cylinder E, and piston-heads D D, substantially as described.

HERMAN F. AMBOS.

Witnesses:

FRED. G. JONES,

CHAS. C. HALL.