

Dec. 9, 1952

E. P. MULLEN

2,620,544

APPARATUS FOR TREATING WEB MATERIAL

Filed Nov. 25, 1950

2 SHEETS—SHEET 1

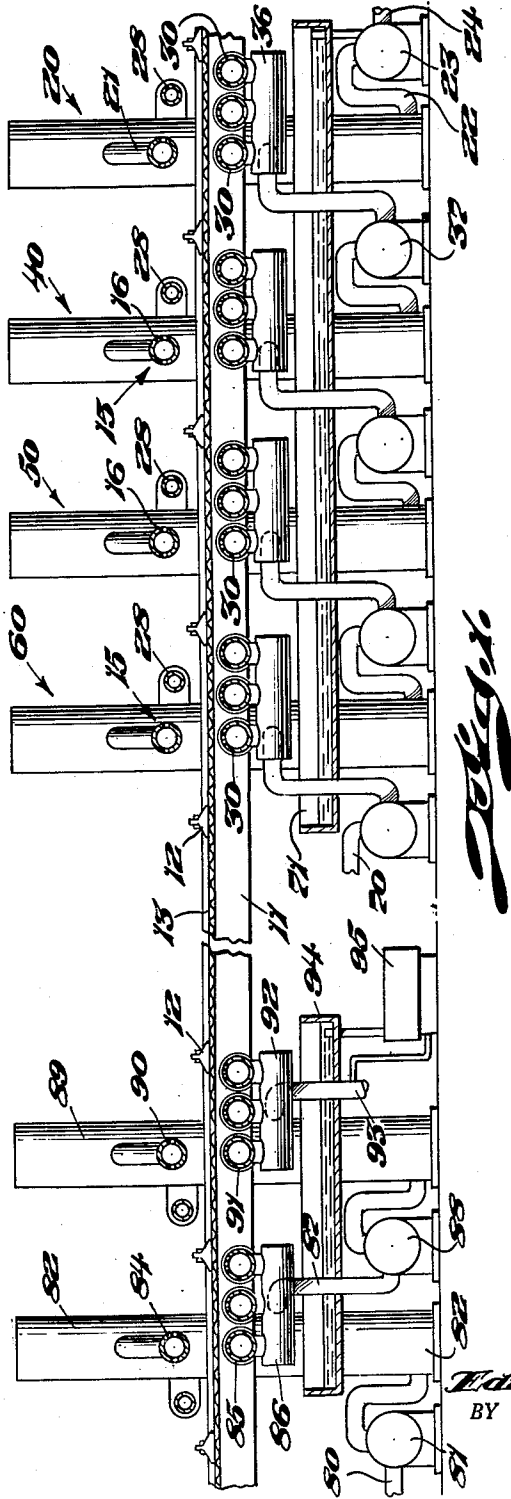

*E. P. Mullen*

INVENTOR.

*Edward P. Mullen*

BY

*Barlow & Barlow*  
Attorneys

Dec. 9, 1952

E. P. MULLEN

2,620,544

APPARATUS FOR TREATING WEB MATERIAL

Filed Nov. 25, 1950

2 SHEETS—SHEET 2

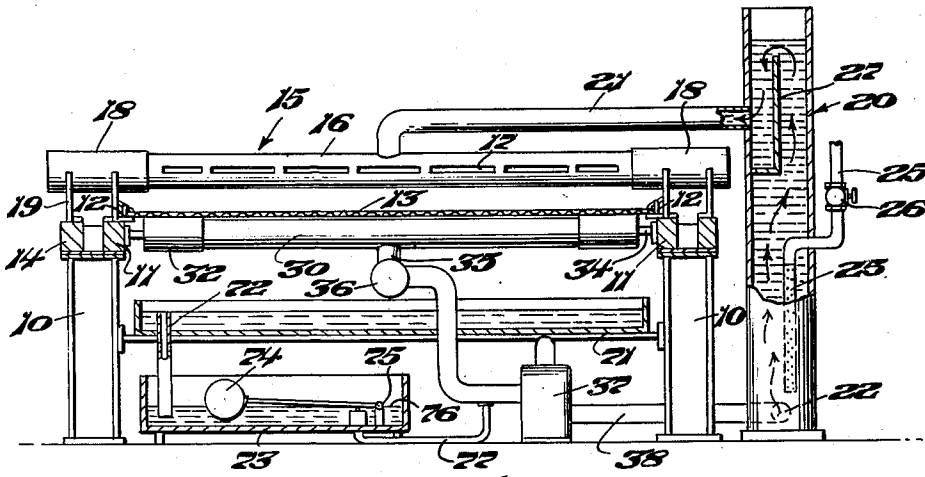

*Fig. 2.*

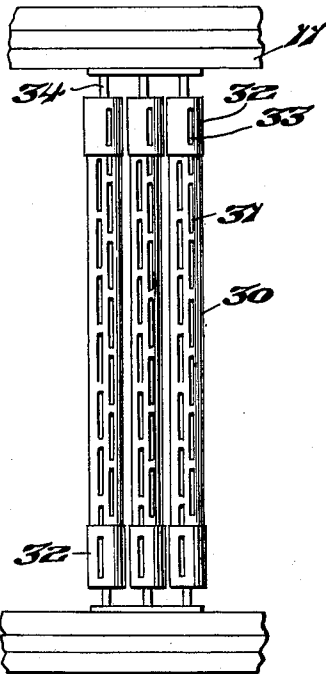

*Fig. 3.*

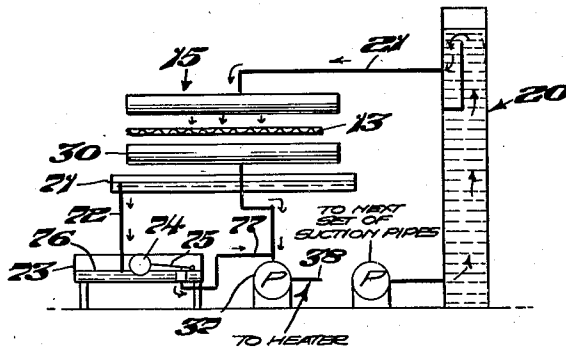

*Fig. 4.*

INVENTOR.

*Edward P. Mullen*

BY

*Barlow & Barlow*  
Attorneys

# UNITED STATES PATENT OFFICE

2,620,544

## APPARATUS FOR TREATING WEB MATERIAL

Edward P. Mullen, Somerset, Mass.

Application November 25, 1950, Serial No. 197,599

4 Claims. (Cl. 26—1)

1

This invention relates to an apparatus and method of treating web material, more particularly to the finishing of fabric.

Heretofore, it has been usual in the finishing of fabric, where mercerizing is done, to immerse the cloth in caustic in an apparatus known as a padder box, and as the web of fabric leaves the padder box, it enters a tenter frame and passes through the tenter frame where it is stretched and then passes through some means for washing the caustic material out of the fabric. During this padding step the fabric shrinks materially both widthwise and lengthwise when the caustic is applied and further shrinks during washing. The stretching which is given on the tenter frame assists to some extent in restricting the shrinking which occurs after padding but yet a considerable amount of shrinking does occur and a consequent loss of fabric yardage takes place.

One of the objects of this invention is to so treat the cloth with caustic and thereafter wash the caustic from the cloth that this shrinking will be materially reduced.

Another object of this invention is to provide an arrangement so that the caustic may be recovered.

Another object of this invention is to reduce the volume of liquids which are used and at the same time provide an opportunity for recovering the caustic from the water where desired.

Another object of this invention is to provide apparatus which may be substituted for the padder for applying the caustic and an apparatus to be substituted for the washing mechanism for washing the caustic from the fabric.

With these and other objects in view, the invention consists of certain novel features of construction, as will be more fully described and particularly pointed out in the appended claims.

In the accompanying drawings:

Figure 1 is a fragmental elevational view partly in section showing a tenter frame with the apparatus which I provide as used with this frame;

Figure 2 is a sectional view showing the upright heater in section;

Figure 3 is a top plan view of the suction means for drawing liquid through the fabric;

Figure 4 is a diagrammatic view illustrating the flow of liquid which is used.

In proceeding with this invention I utilize a tenter frame and eliminate the washing mechanism which is used for washing caustic from the fabric after it passes through the tenter frame as I will apply water to the upper surface of the horizontal run of fabric while in the tenter frame and draw the water applied to the upper surface through the fabric as one step of washing, the apparatus being so arranged that the water which is picked up from the first step of washing will be transferred to be reapplied in the same manner at another location nearer the commencement of the travel of the fabric through the machine. In some cases, the caustic material

2

will be applied by a similar apparatus while the goods are on the tenter frame; thus at all applications of the caustic and the washing of the caustic from the fabric, the web will be under tension where little or no shrinkage can occur, thus maintaining the width and length of the fabric during and after the mercerizing operation.

With reference to the drawings, I provide a tenter frame which is not shown in detail; however, parts which are illustrated comprise the upright standards 10, 10 which are at spaced locations along the length of the machine with tracks 11, 11 at either side of the machine for guiding the tenter chain having clips 12, 12 which travel along the frame and grip and stretch a fabric 13 widthwise. The rails 11 may be adjusted as to width as is usual with tenter frames of this character for accommodating various widths of cloth.

The apparatus which I apply will consist in each instance of a means for washing and comprises a spray head designated generally 15 and which comprises a tube 16 slotted on its opposite sides as at 17 (Fig. 2) extending lengthwise of the tube which is arranged laterally or widthwise of the frame. This tubular center section 16 has non-slotted end sections 18 which telescope over its ends and are fixed to the rails 11 and 14 by brackets 19. Thus, as the rails are moved to provide width adjustment, these end sections 18 of the spray head 15 will be moved to cause the spray head to accommodate the width between the rails.

A tank 20 comprising a cylindrical shell is connected to the spray head by a conduit 21 and this tank is supplied by liquid, which may be water for washing, through conduit 22 by means of the pump 23 which takes water from some suitable source of supply through conduit 24. Within the tank 20 some heating means is provided which in this instance comprises the injection of steam through the conduit 25 which is controlled by valve 26. Also, within this tank, there is a baffle 27 which shields the opening into the conduit 21. Thus, the first stage of washing occurs by the flow of water from the supply conduit 24 through the pump and through conduit 22 to the tank 20 where it is heated and rises, as shown by the arrows, to flow over the top edge of the dam or baffle 27 into the conduit 21 and out through the spray head 15 to drop onto the horizontal fabric which is travelling beneath it while being stretched in the tenter frame. Further, there is also provided the application of steam through a head 28 which may be fixed with relation to the fabric so that further heating is applied through the washing water on the fabric.

Below the fabric 13 and at a location generally below the heads 15 and 28 for the application of the washing water and steam, I will provide a plurality of tubes to which suction is applied. Each of these tubes comprises a central portion 30 (Figs.

3

2 and 3) which is slotted as at 31 and end portions 32 which telescope over these center portions 30 and which are also slotted as at 33. These end portions are fixed to the rails 11 by means of supports 34; thus, they will move with the rails as adjustment for widths of different fabrics occur. The center tube 30 is supported also through a drain pipe 35 which is fixed to a header 36 and receives the water or other liquid which is applied through the heads 15 and 28. A plurality of these tubes 30 are located at spaced intervals along the web and serve to discharge each of the tubes 30 into the header 36. A pump 37 causes a reduced pressure in the header 36 and consequently to each of the tubes 30 through their connection 35 and serves to draw the liquid or water through the tubes 30, header 36 and discharge it through conduit 38 into another tank 40 which is essentially a duplicate of the tank 20 and which provides a second step of the washing operation using the liquid which is first passed through the fabric in the first step previously described over again. A third step of operation using a tank 50 and a fourth step of operation using a tank 60 are provided where similar washings occur progressively using the same washing water and progressively accumulating more caustic washed out of the fabric as the steps progress toward the starting of the fabric through the tenter frame. After the last washing step is performed, the caustic laden wash water will be drawn through tube 70 to some point of reclaiming where the water may be removed and the caustic recovered for further use or this diluted caustic solution may be used as it comes from this machine in other processes where a more diluted treatment of caustic in other finishing operations is to be performed.

Beneath the fabric there is also provided a drip tray 71 which collects drippings from the fabric which have not been collected through the mechanism above mentioned, this drip tray overflowing through pipe 72 to a float controlled tray 73 having a ball 74 for controlling valve 75 to permit the liquid to be discharged should it reach greater than a certain level 76 and transferred through conduit 77 into the suction device 37 which removes the liquid from one of the stages of operation.

In some cases I may desire to apply caustic material directly to the fabric while held in the tenter frame so that shrinkage cannot originally occur and I utilize an apparatus very similar to that which has been heretofore utilized for washing. In the washing operation, however, the water has a counter-flow or a travel in an opposite direction to the direction of travel of the fabric through the tenter frame and in the application of caustic which will be near the entrance of the fabric into the tenter frame, this counter-flow action does not occur. In this case, I may utilize two units or steps of operation. The caustic will be supplied in the strength desired through a conduit 80 and forced by pump 81 into the tank 82 where it will be suitably heated by heaters similar to 25 and discharged through the head 84 onto the fabric 13. This caustic will be collected by the suction tubes 85, delivered to the header 86, and thence by conduit 87 to pump 88 and again delivered to another tank 89 from whence the operation is repeated as in the previous step of application of the caustic. The caustic is thus supplied through spray nozzle 90 and picked up by suction tubes 91 and delivered to header 92, thence through conduit 93 to a

4

point for reclaiming. A trough 94 may be below the fabric at the point of caustic application to pick up any strong caustic which failed to be picked up by the suction devices and will be overflowed into a float controlled trough 95 to return it to a point for recirculation.

I claim:

1. An apparatus for treating web material comprising a tenter frame for engaging and travelling the material under tension means for applying liquid on one side of the web, means collecting the liquid on the other side of the web and reapplying the same liquid at a location near the commencement of travel of the web on the frame.

2. An apparatus for treating web material comprising a tenter frame for engaging and travelling the material under tension means for applying liquid on one side of the web, suction means collecting the liquid on the other side of the web and reapplying the same liquid at a location near the commencement of travel of the web on the frame.

3. An apparatus for mercerizing web material comprising a tenter frame for engaging and travelling the material under tension means for applying caustic to the web at one location near the commencement of the travel of the web on the frame, means for applying at a more advanced location water on one side of the web, means collecting the water on the other side of the web and reapplying the same water at a location near the commencement of travel of the web on the frame.

4. An apparatus for mercerizing web material comprising a tenter frame for engaging and travelling the material under tension, means for applying caustic to the web at one location near the commencement of the travel of the web on the frame, means for collecting the caustic on the other side of the web and reapplying the same caustic at a location near the commencement of the travel of the web on the frame, means for applying at a more advanced location water on one side of the web, means collecting the water on the other side of the web and reapplying the same water at a location near the commencement of travel of the web on the frame.

EDWARD P. MULLEN.

#### REFERENCES CITED

The following references are of record in the file of this patent:

#### UNITED STATES PATENTS

| Number    | Name          | Date          |
|-----------|---------------|---------------|
| 311,349   | Meikle        | Jan. 27, 1885 |
| 1,058,459 | Petzold       | Apr. 8, 1913  |
| 1,626,438 | Voegli        | Apr. 26, 1927 |
| 1,717,870 | Bosshard      | June 18, 1929 |
| 1,752,712 | Uttrich       | Apr. 1, 1930  |
| 1,893,197 | Cohn          | Jan. 3, 1933  |
| 1,980,498 | Nitsche       | Nov. 13, 1934 |
| 2,005,352 | Shaw          | June 18, 1935 |
| 2,045,755 | Cohn          | June 30, 1936 |
| 2,064,512 | Wilson et al. | Dec. 15, 1936 |
| 2,294,141 | Trimble       | Aug. 25, 1942 |

#### FOREIGN PATENTS

| Number | Country       | Date    |
|--------|---------------|---------|
| 4,452  | Great Britain | of 1890 |

#### OTHER REFERENCES

"The Finishing of Woven Fabrics," by E. Midgley Longmans, Green & Co., 1929, pages 133-150. Copy in Div. 21.